

**CATALOG**



## **CABLE TRAY SYSTEMS**

**AB-Cope Cable Trays, Fittings, Nuts & Accessories  
&  
AB-COPE CABLE BUS SYSTEM**

A PART OF

شركة صالح وعبدالعزيز أباحسين المحدودة  
Saleh & Abdulaziz Abahsain Co. Ltd.



# AB-COPE Cable Tray solutions for your infrastructure requirements

Welcome to our new products catalog. For the first time we offer our complete line of Cope cable tray products in a single catalog. This complete catalog is designed for ease of use and to provide the basic information needed to select the proper cable tray system for your needs.

The first section of the catalog provides comprehensive product information, definitions, and technical data needed to select the proper tray. The second section provides industry standards and guidelines for the manufacture and installation of cable tray.

AB-Cope's I-BEAM tray provides a heavy duty welded cable tray for clients requiring I-BEAM side rails. It is perfect for long span locations, heavy loads, and will interface with existing "I" Beam configuration trays.

AB-Cope's Swaged Ladder tray uses our patented swaging system of rung attachment. This system of attachment provides a very rigid tray without welding that is easy to handle and install. The flangeout design provides the maximum access to your cables, even in narrow or divided cable trays.

AB-Cope's Hat Rung tray provides a flange in alternative for those instances where space is critical. With the flanges turned inward, this tray can be fitted into confined spaces. Slotted rungs provide excellent cable tie down capability.

AB-Cope Trof provides the ultimate in cable support for your small diameter, flexible cable. With 1" ribs located every 2" on center, drooping of cable is virtually eliminated.

AB-Cope Channel provides an excellent support system for those applications where only a few cables are needed. It can also be used for separation of services in ladder or trof trays.



AB-Cope Wire Basket Tray provides the superior flexibility and ease of installation required by data-com installations. The exclusive Kwik-Latch system speeds cable tray installation.

AB-Cope Glas fiberglass cable tray provides the answer to many adverse environments. Life cycle costs, long span capability and easy field modification make AB-Cope Glas an ideal choice for industrial, chemical, and petro-chemical facilities.

Our customer service team is available to assist with questions about application, installation, and availability of our products.

Thank you for considering AB-Cope for your cable tray requirements.

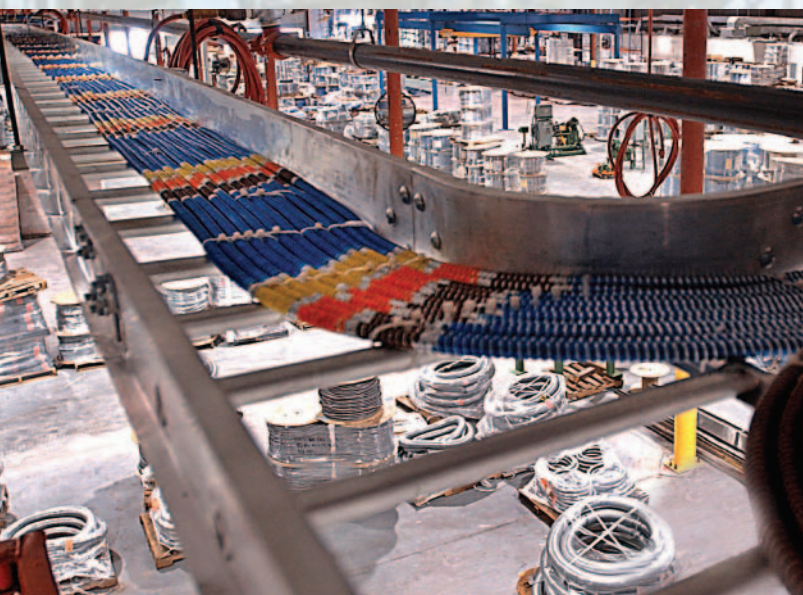

### AB-COPE

Saleh & Abdulaziz Abahsain Co. Inc. was established in 1947 as the first electrical contractor in Saudi Arabia and now has numerous trading, manufacturing and contracting ventures throughout the kingdom, ranks 48th among top 100 companies of Saudi Arabia listed per 2011 survey.

In 1981, Saleh & Abdulaziz Abahsain Co. Ltd. of Al Khobar, Saudi Arabia and T. J. Cope Inc. of Collegeville, PA, U.S.A. formed a joint venture known as ABAHSAIN-COPE S.A. LTD. with commercial registration no. 2051007066, manufacturers of A.S.T.M. cable ladder conforming to NEMA metal cable tray standard publication VE-1. T. J. Cope was incorporated in 1880 in the United States. Our cable ladder produced in Saudi Arabia by ABAHSAIN-COPE is identical in size, material design and method of manufacture as that manufactured by T. J. Cope in the United States. Technical assistance is available from both locations.

In 1983, Abahsain-Cope expanded its manufacturing capability to include metal framing, or as it is commonly referred to as STRUT.

In 1985, Abahsain-Cope started manufacturing its product line now known as Cope-Tray, which is a light duty cable tray system.

Abahsain-Cope manufacturing facilities are located four kilometers north of old Dhahran Airport on the west side of Dammam-Dhahran Airport road in Dhahran, Saudi Arabia and 2<sup>nd</sup> industrial Area Dammam.

Since began manufacturing in 1981, **Abahsain-Cope** have supplied complete Cable ladder/tray, Strut systems and are approved manufacturers for ARAMCO, SABIC, SABIC affiliate companies, MARAFIQ, SWCC, SEC in **SAUDI ARABIA** and for **All regional** Petrochemical, Oil & Gas, Water & Power companies e.g. KOC, MEW, KNPC, ADNOC, AMOCO, Dubai Petroleum, NPCC, Dugas, PDO, ALBA, BAPCO, QP, MPC, ENPPI, Elf Aquipaine Prod., Al Furat Petroleum, PNOC.

AB-COPE offers complete Cable management solution including **Unistrut metal framing**, **Cope ladder**, **Airedale - Abcope tray**, **Cable runway system** and **Cable trays** conforming to NEMA metal standard publication VE-1. And fiberglass standard NEMA FG-1. also Authorized manufacturer of Unistrut Metal Framing **UNISTRUT®**

In full compliance of



### SECTION 1 Features & Technical Data

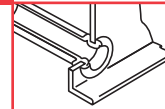

Cutaway –  
Cope Swage

### SECTION 2 NEMA Standard VE-1



### SECTION 3 AB-Cope LADDER



### SECTION 4 AB-Cope I-BEAM



### SECTION 5 AB-Cope HAT



### SECTION 6 AB-Cope TROF



### SECTION 7 AB-Cope CHANNEL



### SECTION 8 AB-COPE-GLAS



### SECTION 9 AB-COPE WIRE BASKET



### SECTION 10 AB-COPE TRAY

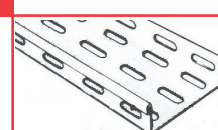

|                   |                         |
|-------------------|-------------------------|
| <b>SECTION 11</b> | <b>AB-COPE TRUNKING</b> |
|-------------------|-------------------------|

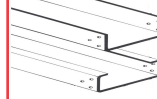

|                   |                           |
|-------------------|---------------------------|
| <b>SECTION 12</b> | <b>AB-COPE UNI-LADDER</b> |
|-------------------|---------------------------|

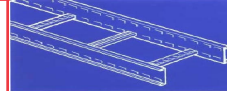

|                   |                       |
|-------------------|-----------------------|
| <b>SECTION 13</b> | <b>AB-COPE RUNWAY</b> |
|-------------------|-----------------------|



|                   |                          |
|-------------------|--------------------------|
| <b>SECTION 14</b> | <b>AB-COPE CABLE BUS</b> |
|-------------------|--------------------------|

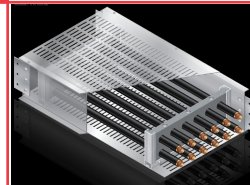

**Headquarters:**

P.O Box 209 ,  
Al Khobar - 31952  
King Abdulaziz Boulevard  
Tel : - 966-3-8984045  
Fax:- 966-3-8991557

**Manufacturing:**

P.O. BOX 3574,  
AL KHOBAR 31952,  
STREET NO. 136, 2ND INDUSTRIAL CITY  
DAMMAM SAUDI ARABIA.  
TELL NO. 013 8086568  
E MAIL: akma@abahsain.net

In full compliance of



## OVERVIEW

### SELECTING A AB-COPE CABLE TRAY SYSTEM

A number of factors must be considered when selecting the proper cable tray system and planning the installation:

- Material and Finish
- Types of Cable Tray
- NEMA Class
- Cavity Size – Load Depth/Width of Tray
- Length of Straight Sections
- Rung Spacing
- Radius of Fittings
- Cable Tray Support Locations
- Electrical Grounding

### CABLE TRAY SYSTEM DRAWING LEGEND

- 1 Straight Section, Ladder (SL)
- 2 Horizontal Elbow, 90°, Ladder Type (9F)
- 3 Horizontal Elbow, 30° (3F), 45° (4F) or 60° (6F)
- 4 Horizontal Cross, Ladder Type (FC)
- 5 Horizontal Tee, Ladder Type (FT)
- 6 Vertical Elbow, Outside, 90° (90)
- 7 Vertical Elbow, Outside & Inside, 30° (30, 31), 45° (40, 41), or 60° (60, 61)
- 8 Vertical Tee, Solid Bottom Trof Type (VT)
- 9 Straight Section, Solid Bottom Trof (SL)
- 10 Flanged Solid Cover (FS)
- 11 Barrier Strip-Straight Section (SB)
- 12 Barrier Strip-Flexible-Horizontal Fitting (FB)
- 13 Straight Section, Channel (SL)
- 14 Blind End (BE)
- 15 Box Connector (BC)
- 16 Angle Connector (CA)
- 17 Reducing Connector (CO)
- 18 Universal Curvilinear Connector (RC)

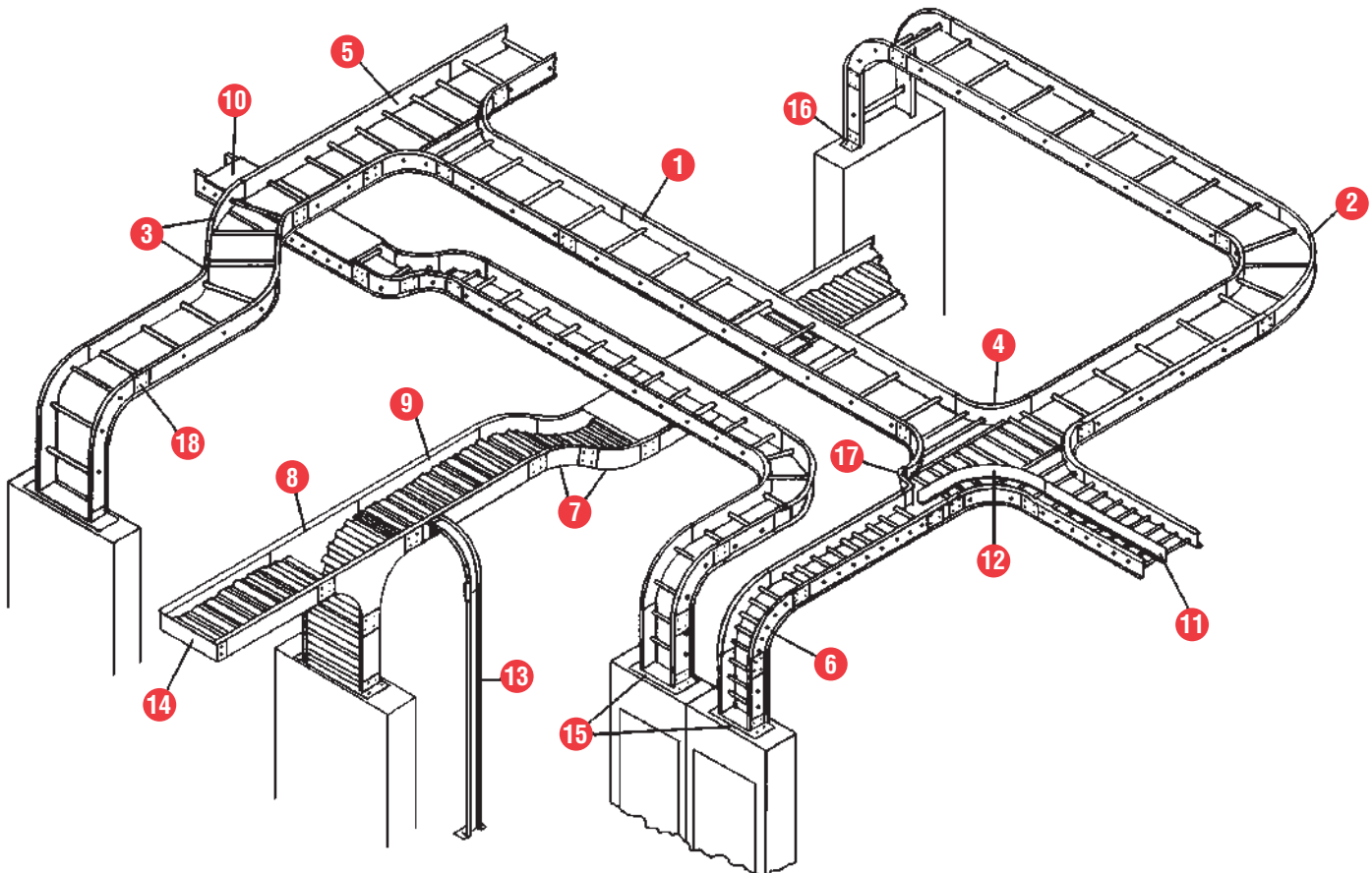

### TYPES OF CABLE TRAY

Any assembly of cable tray straight sections, fittings and accessories that form a rigid system to support cables is a cable tray. The different types of tray designs are described below.

#### Ladder

A prefabricated metal structure consisting of two side rails connected by individual transverse members or rungs.

Ladder tray is the most common and the most economical type of tray. It also provides maximum ventilation for cabling.

#### I-Beam

Cope I-Beam cable tray system provides long span capability and versatility. Cope I-Beam interfaces with existing "I" Beam configurations.

#### Ventilated Trof

A prefabricated metal structure with clear openings no greater than 4".

Trof cable trays are the best choice for smaller cables. Ventilated trofs offer some air-flow while completely eliminating cable sagging.

#### Solid Trof

A prefabricated metal structure consisting of a bottom with no openings within the cable bearing surface.

Solid bottom cable trays completely eliminate cable sagging and offer the most protection for the cables.

#### Channel

A prefabricated metal structure consisting of a one-piece ventilated or solid bottom channel section not exceeding 6" in width.

#### Cope-Glas

Fiberglass cable tray provides the answer to many adverse environments. Life cycle costs, long span capability and easy field modification make Cope Glas™ an ideal choice for industrial, chemical, and petro-chemical facilities.

#### Wire Basket

Provides the superior flexibility and ease of installation required by data-com installations. The exclusive Kwik-Latch system speeds cable tray installation.

### MATERIALS AND FINISH

The material selection is based on the environmental conditions and economic considerations for the project.

#### Steel – Pre-Galvanized

Hot Dip Mill-Galvanized steel (ASTM-A-653-G90 CS) is zinc coated by a hot dip process. Steel strip from a coil is fed through a continuous zinc coater which cleans, fluxes and coats the steel with molten zinc. After cooling, the steel is recoiled. The pre-galvanized coating provides a total weight of 0.90 oz. of zinc for both sides of one square foot of material.

Mill galvanized ladder is made of pre-galvanized steel and generally used indoors or in locations not exposed to the elements or corrosives.

#### Steel – Hot Dip Galvanized After Fabrication

In hot dip galvanizing after fabrication (HDGAF), the finished part is immersed in a bath of molten zinc (ASTM 123). This method results in complete zinc coverage and a thicker coating than pregalvanized or electro-plated steel.

The zinc coating is typically 2.6 MIL or 1.5 oz./sq. ft. of surface area.

This is the coating of choice for applications where protection from severe corrosion is a design factor.

#### Stainless Steel

Type 304 and Type 316 stainless steel material in accordance with ASTM-A-240.

#### Aluminum

Aluminum material in accordance with AA-6063-T6. Aluminum trays are suitable for most outdoor applications and offer reductions in total installed costs.

#### Fiberglass

For extremely corrosive areas, Cope offers the most complete line of Fiberglass cable trays available. For a complete Cope "Cope-Glas" catalog, please contact the factory or the Cope representative in your area.

#### Special Finishes

For extremely corrosive areas Cope can supply a PVC (polyvinyl chloride) coating over aluminum or uncoated steel. This is applied using the fluidized bed process to a nominal thickness of 12 mils.

Weathering steel is also available; contact factory for availability.

# PRODUCT FEATURES

## OVERVIEW

### AB-COPE SWAGE LADDER

(pages 24 – 63)

Is a structure consisting of two side rails, connected by individual rungs and is manufactured in accordance with NEMA Standard VE-1. AB-Cope rungs are fastened to the sidemembers by an exclusive swaging process. This assembly method insures a superior mechanical and electrical connection.

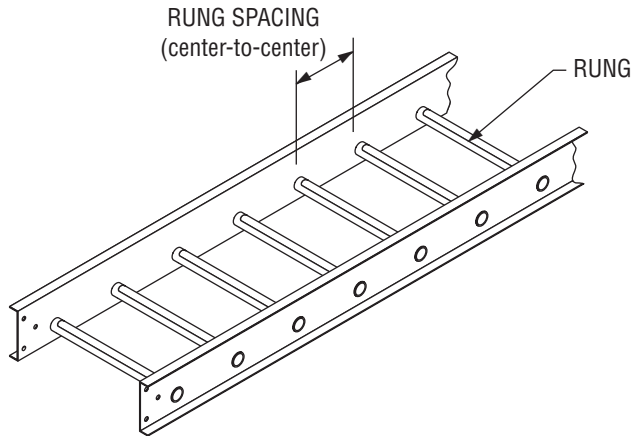

### AB-COPE HAT

(pages 100 – 133)

Is a prefabricated metal structure consisting of reinforced hat-shaped rungs, arc-welded to the side rails, and is manufactured to NEMA Standard VE-1. AB-Cope Hat rungs are fastened to the side rails with an automatic, self-indexing MIG-arc-welding system, plug welding a 1/2" diameter zone. The superior strength of the AB-Cope plug weld withstands the rigors of shipping, handling, erection, and cable support service.

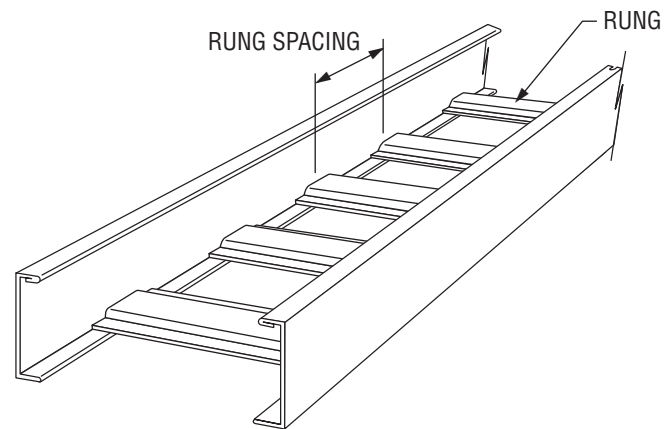

### AB-COPE I-BEAM

(pages 64 – 99)

AB-Cope I-Beam cable tray system provides long span capability and versatility. AB-Cope I-Beam interfaces with existing "I" Beam configurations.

AB-Cope Offers a complete system of I-Beam products and accessories to meet all your project requirements.

In the following pages you'll find the products, accessories, specifications, and technical data for the AB-Cope I-Beam cabletray system.

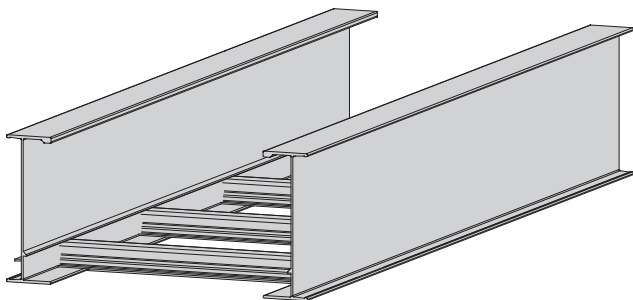

### AB-COPE TROF

(pages 134 – 169)

Is a prefabricated metal structure consisting of ventilated or solid bottoms, welded to the side rails, and are manufactured and tested to NEMA Standard VE-1. Straight sections, fittings (elbows, tees, crosses, reducers, etc.), and a full line of matching and interfacing accessories are available. Corrugations give great lateral rigidity to the bottom transmitting the load to the side rails. Lateral (transverse) deflection is nearly eliminated compared to rung type trofs where the rails are not continuously braced by the bottom. Cope Corrugated bottoms do NOT limit the tray load capacity.

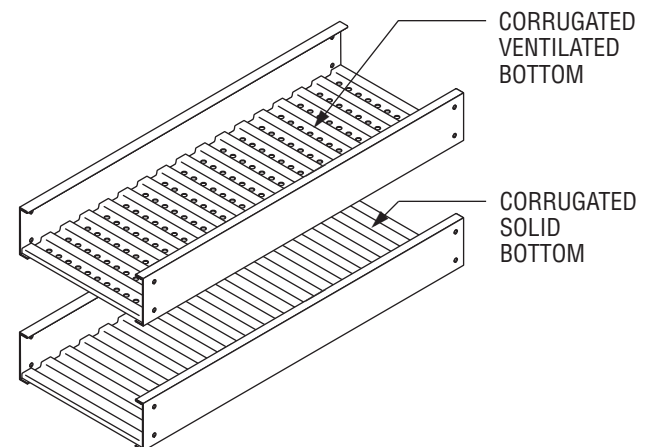

**AB-COPE CHANNEL**

(pages 170 – 181)

AB-Cope Channel supports single branches of power or multiconductor control cable or instrument tubing. Ideal for communication, fire alarm, or call station and clock cabling. A complete line of devices are available for interfacing with AB-Cope Ladders and Cope Trofs.

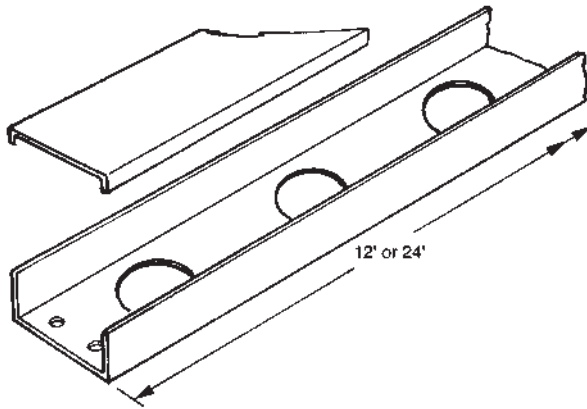

**AB-COPE WIRE BASKET**

(pages 224 – 257)

Wire basket tray is a welded wire mesh cable management system produced from high strength steel wires. Wire basket tray is produced by first welding a net, forming the channel, and then finishing after fabrication. The 2" x 4" mesh permits continuous airflow to help prevent heat buildup. In addition this unique open design prevents the buildup of dust, contaminants, and bacterial proliferation.

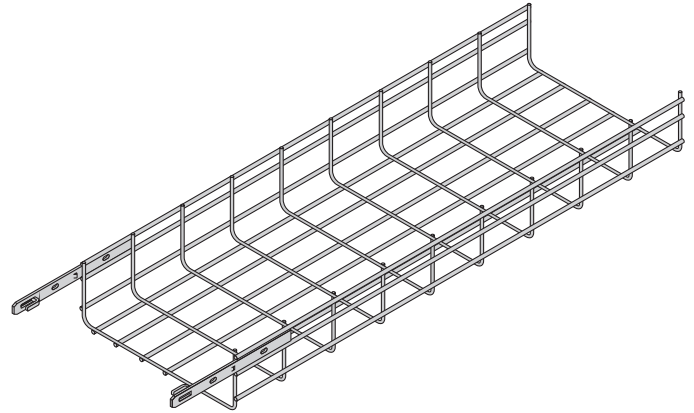

**AB-COPE-GLAS**

(pages 182 – 223)

Engineers, designers, contractors, installers and end users have many reasons to choose AB-COPE-GLAS cable tray for their power, signal, and control distribution support requirements.

AB-COPE-GLAS cable tray systems are available in a variety of sizes and styles. A standard or special design can be fabricated for any indoor or outdoor application regardless of size.

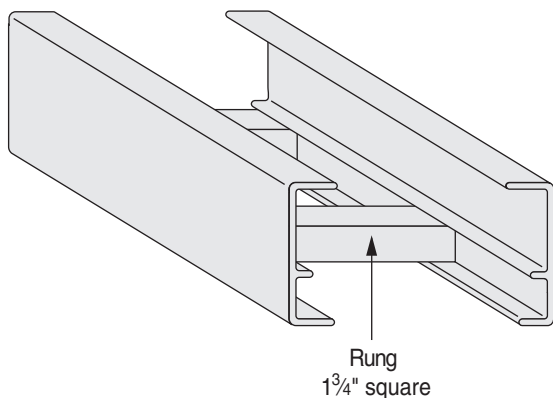

# PRODUCT FEATURES

## ASSOCIATED PRODUCTS

### Power-Strut® Metal Framing System

#### Trapeze Support System

Power-Strut metal framing is ideal for electrical and mechanical pipe support applications.

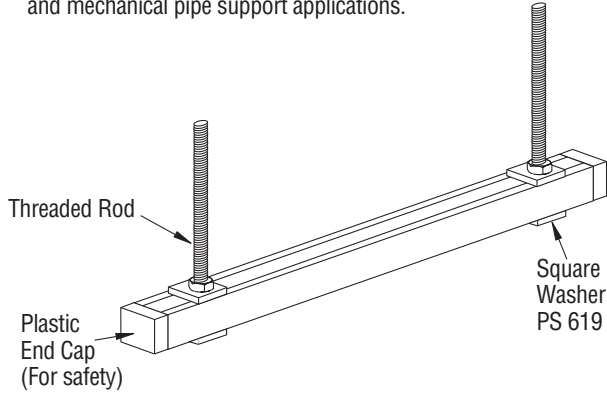

Acceptable Methods to Hang Channels

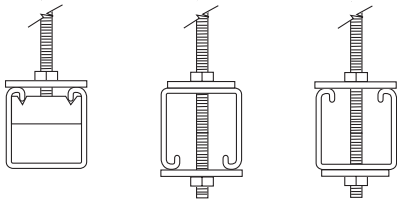

Pre-slotted channel allow through channel connections

#### Overhead Multi-Use Support Systems Using Channel Attached to "I" Beams

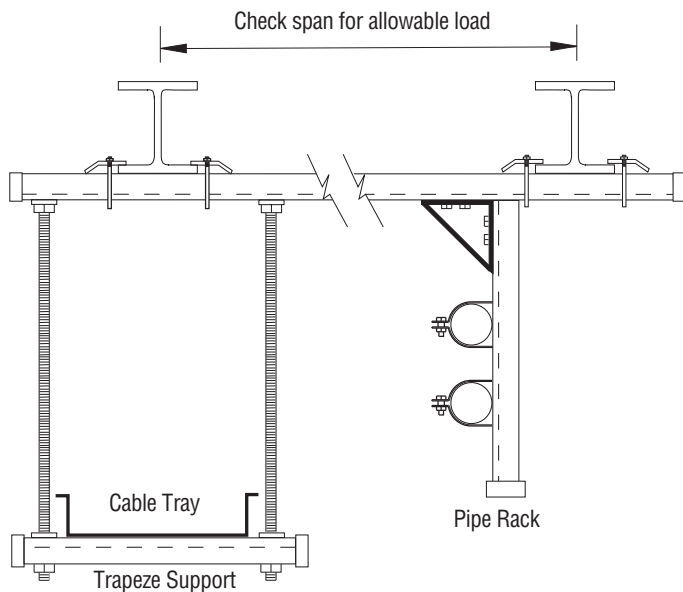

#### Standard Channel and Fitting Assembly

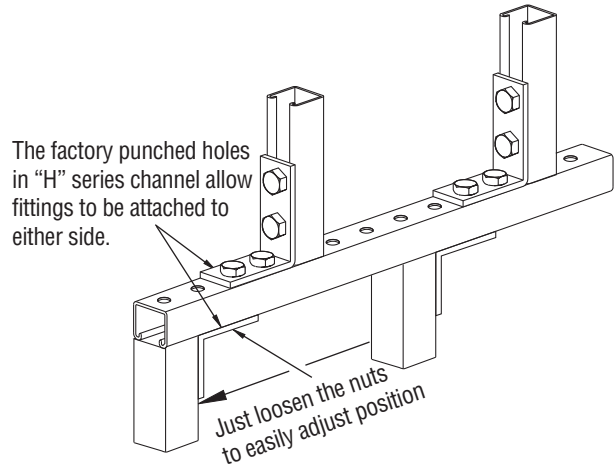

#### Ganged Pipe Support

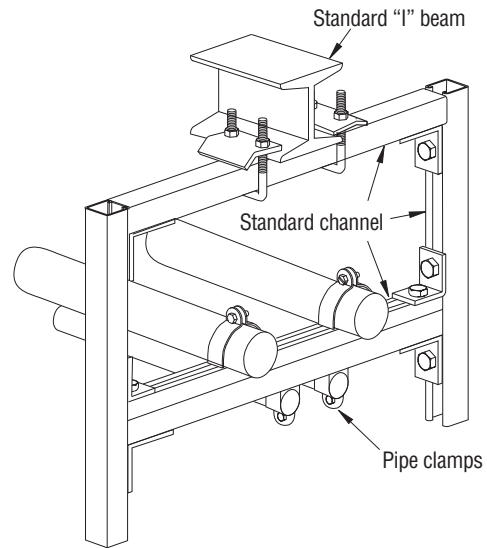

Stock brackets are available in lengths from 6" to 36"

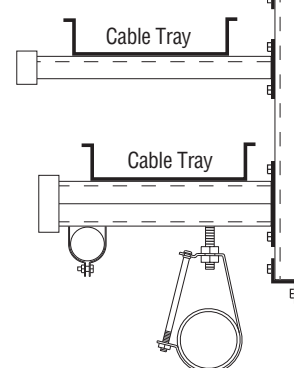



# STANDARDS

# 2

## Industry Standards and Guidelines

AB-Cope products are produced in accordance with the standards of NEMA (National Electrical Manufacturers Association) and in accordance with CSA (Canadian Standards Association).

This section presents standards and guidelines for products and installation. They can be used as a reference for specifications and procedures.

## STANDARDS

### SECTION 1 – REFERENCED STANDARDS & DEFINITIONS

#### 1.1 REFERENCED STANDARDS

In this publication, reference is made to the standards listed below. Copies are available from the indicated source.

##### **ANSI/NFPA 70-93 National Electrical Code®**

###### **American National Standards Institute**

**25 West 43rd Street, 4<sup>th</sup> Floor  
New York, NY 10036**

###### **National Fire Protection Association**

**1 Batterymarch Park  
Quincy, Massachusetts  
USA 02169-7471**

- A123** Zinc (Hot-Dip Galvanized) Coatings on Iron and Steel Products, Specifications for
- A653** General Requirements, Steel Sheet, Zinc-Coated (Galvanized) by the Hot Dip Process, Specifications for
- B633** Electrodeposited Coatings of Zinc on Iron and Steel, Specifications for
- B766** Electrodeposited Coatings of Cadmium, Specification for

**ASTM International  
100 Barr Harbor Drive  
PO Box C700**

**West Conshohocken, PA, 19428-2959**

#### 1.2 DEFINITIONS

**Metallic Cable Tray System** – An assembly of cable tray straight sections, fittings, and accessories that forms a rigid structural system to support cables.

**Ladder Cable Tray** – A prefabricated metal structure consisting of two longitudinal side rails connected by individual transverse members.

**Trof Cable Tray** – A prefabricated metal structure consisting of a ventilated bottom pan or rungs\* within integral or separate longitudinal side rails.

*\*The cable tray bottom will have openings sufficient for the passage of air and utilize 75 percent or less of the plan area of the surface to support cables. The maximum distance between cable support surfaces shall not exceed 100 mm (4") in the direction parallel to the cable tray side rails.*

**Solid Bottom Cable Tray** – A prefabricated metal structure consisting of a bottom with no openings within integral or separate longitudinal side rails.

**Straight Section** – A length of cable tray which has no change in direction or size.

**Cable Tray Fitting** – A device which is used to change the direction or size of a cable tray system.

**Cable Tray Connector (Splice Plate)** – A device which joins cable tray straight sections and fittings, or both.

The basic types of connectors (splice plates) are:

- Rigid
- Expansion
- Adjustable
- Reducer

**Fasteners** – Screws, nuts, bolts, washers, rivets, pins, and other items used to assemble a cable tray system.

**Horizontal Elbow (Horizontal Bend)** – A cable tray fitting which changes the direction in the same plane. Standard degrees of bend are 90°, 60°, 45°, and 30°.

**Horizontal Tee** – A cable tray fitting which is suitable for joining cable trays in three directions at 90° intervals in the same plane.

**Horizontal Cross** – A cable tray fitting which is suitable for joining cable trays in four directions at 90° intervals in the same plane.

**Vertical Elbow (Vertical Bend)** – A cable tray fitting which changes direction to a different plane. Standard degrees of bend are 90°, 60°, 45°, and 30°.

An inside vertical elbow changes direction upward from the horizontal plane.

An outside vertical elbow changes direction downward from the horizontal plane.

**Vertical Tee** – A cable tray fitting which is suitable for joining cable trays in three different directions at 90° intervals in different planes.

**Reducer (Straight, Right Hand, Left Hand)** – A cable tray fitting which is suitable for joining cable trays of different widths in the same plane.

A straight reducer has two symmetrical offset sides.

A right-hand reducer, when viewed from the large end, has a straight side on the right.

A left-hand reducer, when viewed from the large end, has a straight side on the left.

**Channel Cable Tray** – A prefabricated metal structure formed from one piece of metal and having either a ventilated bottom or solid-bottom. The channel shall not exceed 152 mm (6") in width.

## NEMA STANDARDS

**Accessories** – Devices which are used to supplement the function or plane of straight sections and fittings, and include such items as adjustable splices (horizontal and vertical), dropouts, covers, conduit adapters, hold-down devices and dividers.

**Cable Tray Support** – A device which provides adequate means for supporting cable tray sections and fittings.

The basic types of cable tray supports are:

- Cantilever bracket
- Trapeze
- Single rod suspension.

**Cable Tray Support Span** – The distance between the center lines of supports.

## SECTION 2 – MANUFACTURING STANDARDS

### 2.1 MATERIALS

Cable tray systems shall be made of either corrosion-resistant metal or metal with a corrosion-resistant finish. Aluminum and stainless steel alloys are inherently corrosion-resistant and no finish coating is required in most environments.

### 2.2 FINISHES

**2.2.1** Carbon steel used for cable trays shall be protected against corrosion by one of the following processes:

A. Hot-dip mill galvanized in accordance with ASTM Publication No. A653.\*

\*Coating designation G90 of ASTM 653 has an average zinc coating weight of 1.25 oz. per square foot (0.381 kg/m<sup>2</sup>) of steel total coating on both surfaces (1.06 mils or 0.027mm) average thickness per side).

Hot-dip mill galvanized coatings are produced by continuous rolling steel sheets or strips in coils through a bath of molten zinc. The process involves pre-treating the steel to make the surface react readily with molten zinc as the strip moves through the bath at high speeds. During fabrication where slitting, forming, cutting, or welding is performed, the cut edges and heat-affected zone of welding are subject to superficial oxidation. These areas are then protected through electrolytic action of the adjacent zinc surfaces. The coating is smooth, ductile, and adherent.

B. Hot-dip galvanized after fabrication in accordance with ASTM Publication No. A123. Grade 65. It is important to specify ASTM A653 or ASTM A123 to insure the specific coating is furnished.

Grade 65 of ASTM A123 has an average zinc coating weight of 1.50 oz. per square foot (0.46 kg/m<sup>2</sup>) (2.55 mils or 0.064mm) average thickness per side).

Fabricated products which are hot-dip galvanized are thoroughly cleaned, fluxed, and immersed into a bath of molten zinc where they react to form a metallurgical bonded zinc coating. Normal oxidation of the galvanized surfaces will, in a short period of time, appear as a dull gray or white coating. Some degree of roughness and variations of thickness can be expected due to the hot dipping process. Because the galvanizing process takes place at the low end of the stress-relieving temperature range, some stress relief occurs and some distortion or warping may result.

C. Other equivalent commercially available coatings.

**2.2.2** Steel nuts and bolts shall be protected against corrosion by one of the following processes:

- A. ASTM Publication No. B633
- B. ASTM Publication No. B766
- C. Other equivalent commercially available coatings.

**2.2.3** Where metallic cable tray is intended for installation in highly corrosive environments, including most alkaline and acidic conditions, further protection against corrosion shall be provided by one of the following processes:

A. PVC (Polyvinylchloride) – A PVC coating shall be applied in a fluidized bed or by electrostatic spray. The coating thickness shall be 15 mils (0.381 mm) ± 5 mils (±0.127mm).

Items to be protected shall be thoroughly cleaned, primed, and then coated with a fine grain UV (ultraviolet) stabilized vinyl plastic powder.

All field cuts and damaged areas of coated tray shall be repaired with a compatible PVC compound to ensure a coating integrity.

A PVC coating is generally applied to bare steel cable tray but can also be applied in aluminum cable tray. PVC is not recommended as a coating on galvanized steel cable trays because of rough surfaces and gas emissions which cause voids and adhesion problems.

B. Other equivalent commercially available coatings.

## NEMA STANDARDS

### 2.3 DIMENSIONS

#### 2.3.1 General

Plus or minus values stated reflect the range of nominal dimensions in cable tray designs and are not intended to represent manufacturing tolerances.

#### 2.3.2 Ladder Trays

- Lengths of Straight Sections** – NEMA - 12' (3660mm)  $\pm 3/16"$  (4.76mm) and 24' (7320mm)  $\pm 5/16"$  (7.94mm), not including connectors if attached. CSA - 10' (3000mm)  $\pm 3/16"$  (4.76mm) and 20' (6,000mm)  $\pm 5/16"$  (7.94mm), not including connectors if attached.
- Widths** - 6", 12", 18", 24", 30", and 36" (152mm, 305mm, 457mm, 610mm, 762mm and 914mm),  $\pm 1/4"$  (6.35mm) inside dimension. Overall widths shall not exceed inside widths by more than 4" (102mm).
- Depths** - Inside depths shall be 3", 4", 5", and 6" (76.2mm, 102mm, 127.0mm, and 152mm),  $\pm 3/8"$  (9.53mm). Outside depths shall not exceed inside depths by more than 1 1/4" (31.7mm).
- Rung Spacing on Straight Sections** - 6", 9", 12", or 18" (152mm, 229mm, 305mm, or 457mm) on centers.
- Radii** - 12", 24", and 36" (305mm, 610mm, and 914mm).
- Degree of Arc for Elbows** - 30°, 45°, 60°, and 90°.

#### 2.3.3 Trof Trays

- Lengths of Straight Sections** – NEMA - 12' (3660mm)  $\pm 3/16"$  (4.76mm) and 24' (7320mm)  $\pm 5/16"$  (7.94mm), not including connectors if attached. CSA - 10' (3000mm)  $\pm 3/16"$  (4.76mm) and 20' (6,000mm)  $\pm 5/16"$  (7.94mm), not including connectors if attached.
- Widths** - 6", 12", 18", 24", 30", and 36" (152mm, 305mm, 457mm, 610mm, 762mm and 914mm),  $\pm 1/4"$  (6.35mm), inside dimension. Overall widths shall not exceed inside widths by more than 4" (102mm).
- Depths** - Inside depths shall be 3", 4", 5", and 6" (76.2mm, 102mm, 127mm, and 152mm),  $\pm 3/8"$  (9.53mm). Outside depths shall not exceed inside depths by more than 1 1/4" (31.7mm).
- Radii** - 12", 24", and 36" (305mm, 610mm, and 914mm).
- Degrees of Arc for Elbows** - 30°, 45°, 60°, and 90°.
- Transverse Elements** - The maximum open spacing between transverse elements shall be 4" (102mm) measured in a direction parallel to the tray side rails.

#### 2.3.4 Solid-Bottom Trays

- Lengths of Straight Sections** NEMA - 12' (3660mm)  $\pm 3/16"$  (4.76mm) and 24' (7320mm)  $\pm 5/16"$  (7.94mm), not including connectors if attached. CSA - 10' (3000mm)  $\pm 3/16"$  (4.76mm) and 20' (6,000mm)  $\pm 5/16"$  (7.94mm), not including connectors if attached.
- Widths** - 6, 12, 18, 24, 30, and 36" (152mm, 305mm, 457mm, 610mm, 762mm and 914mm)  $\pm 1/4"$  (6.35mm), inside dimension. Overall widths shall not exceed inside widths by more than 4" (102mm).
- Depths** - inside depths shall be 3", 4", 5", and 6" (76.2mm, 102mm, 127mm, and 152mm),  $\pm 3/8"$  (9.53mm). Outside depths shall not exceed inside depths by more than 1 1/4" (31.7mm).
- Radii** - 12", 24", and 36" (305mm, 610mm, and 914mm).
- Degree of Arc for Elbows** - 30°, 45°, 60°, and 90°.
- Bottom** - Bottom is solid.

#### 2.3.5 Channel Trays

- Lengths of Straight Sections** - 12' (3660mm)  $\pm 3/16"$  (4.76mm) and 24' (7320mm)  $\pm 5/16"$  (7.94mm), not including connectors if attached.
- Widths** - 3", 4", and 6" (76.2mm, 102mm, and 152mm),  $\pm 1/4"$  (6.35mm), inside dimension.
- Depths** - 1 1/4" to 1 3/4" (31.7mm to 44.4mm) outside dimensions.
- Radii** - 12", 24", and 36" (305mm, 610mm, and 914mm).
- Degree of Arc for Elbows** - 30°, 45°, 60°, and 90°.

### 2.4 PROTECTION OF CABLE INSULATION

The inside of cable tray systems shall not have sharp edges, burrs, or projections which can damage cable insulation.

### 2.5 FITTINGS

The design and construction of fittings shall be based on the assumption that they will be supported in accordance with the recommendations given in 6.6 for support locations.

### 2.6 MARKING OF TRAYS WHEN USED AS EQUIPMENT GROUNDING CONDUCTORS

When steel or aluminum cable tray systems are used as equipment grounding conductors, cable tray sections and fittings shall be marked to show the minimum cross-sectional area in accordance with the Article 392 of the National Electrical Code®.

AB-CopeCable Tray Systems

## NEMA STANDARDS

### SECTION 3 - PERFORMANCE STANDARDS & LOAD/SPAN CLASS DESIGNATIONS

#### 3.1 WORKING (ALLOWABLE) LOAD CAPACITY

The working (allowable) load capacity represents the ability of a cable tray to support the static weight of cables. It is equivalent to the destruction load capacity, as determined by testing in accordance with 4.1 divided by a safety factor of 1.5.

#### 3.2 LOAD/SPAN CLASS DESIGNATIONS

There shall be three working load categories of cable tray:\*

- 50 lbs/linear ft. (74.4 kg/m) (Symbol A)
- 75 lbs/linear ft. (111.6 kg/m) (Symbol B)
- 100 lbs./linear ft. (148.8 kg/m) (Symbol C) and, four support span categories of:
- 8' (2.44m), 12' (3.66m), 16' (4.87m), 20' (6.09m)

Utilizing these above, load/span class designations are presented in the table below:

**LOAD/SPAN CLASS DESIGNATIONS**

| Working Lbs./Ft | Load (kg/m) | Support Feet | Span (m) | NEMA Class |
|-----------------|-------------|--------------|----------|------------|
| 50              | (74.4)      | 8            | (2.44)   | 8A         |
| 75              | (116.6)     | 8            | (2.44)   | 8B         |
| 100             | (148.8)     | 8            | (2.44)   | 8C         |
| 50              | (74.4)      | 12           | (3.66)   | 12A        |
| 75              | (116.6)     | 12           | (3.66)   | 12B        |
| 100             | (148.8)     | 12           | (3.66)   | 12C        |
| 50              | (74.4)      | 16           | (4.87)   | 16A        |
| 75              | (116.6)     | 16           | (4.87)   | 16B        |
| 100             | (148.8)     | 16           | (4.87)   | 16C        |
| 50              | (74.4)      | 20           | (6.09)   | 20A        |
| 75              | (116.6)     | 20           | (6.09)   | 20B        |
| 100             | (148.8)     | 20           | (6.09)   | 20C        |

NOTE 1 - The above working loads are for cable only; when considering applications requiring concentrated static load, see 6.2.

NOTE 2 - These designations do not apply to channel tray, and the manufacturer should be consulted.

NOTE 3 - For deflection see 6.1.

### SECTION 4 - TEST STANDARDS

#### 4.1 DESTRUCTION LOAD TEST

##### 4.1.1 Test Specimen

For each design of cable tray, two separate tests shall be made. An un-spliced straight section of the widest width shall be used in each test.

For ladder type cable trays rung spacing shall be 12" on center.

Differences in gauge, height of side rails, rung or bottom to side rail connection, or the configuration of any part constitute a different design.

##### 4.1.2 Type and Length of Span

Test spans shall be simple beam spans with free unrestrained ends. Trays shall not have side restraints. Span lengths shall be as specified  $\pm 1\frac{1}{2}$ " (38 mm).

##### 4.1.3 Orientation of Specimens

Specimens shall be tested in a horizontal position. The total length of the test specimen shall be not more than the specified span length plus 20%. Any overhang shall be equal.

##### 4.1.4 Supports

Each end of the specimen shall be supported by an 1 $\frac{1}{8}$ " (30 mm) wide by  $\frac{3}{4}$ " (19 mm) high steel bar(s) with a 120° "V" notch cut in its bottom to a depth of  $\frac{3}{16}$ " (5 mm). The "V" notch shall rest on a 1" (25 mm) solid round steel bar which is securely fastened to a rigid base, or the specimen shall be supported directly on a 2 $\frac{1}{2}$ " (65 mm) maximum diameter round steel bar or heavy wall steel tube fastened to rigid base.

##### 4.1.5 Loading Material

Loading material shall be steel strips, lead ingots, or other loading material.

Steel strips shall have rounded or de-burred edges, a maximum thickness of  $\frac{1}{8}$ " (3 mm), a width of 4" (100 mm), and a maximum length of 24' (7320 mm).

Five lead ingots, each weighing approximately 5 pounds (2.3 kg), shall be interconnected across corners into a string of 5 ingots approximately 22" (550 mm) long. Individual ingots are normally hexagonal, approximately 3" (75 mm) in diameter, and 1 $\frac{1}{2}$ " (38 mm) deep.

Other loading material shall have a maximum weight of 10 pounds (4.5 kg), a maximum width of 5" (125 mm), and a maximum length of 12" (300 mm).

##### 4.1.6 Loading

All specimens shall be loaded to destruction. The load shall be applied in at least 10 increments which are approximately equal.

Loading shall be uniformly distributed for the length and breadth of the specimen except that the loading material shall be not closer than  $\frac{1}{2}$ " (13 mm) nor further than 1" (25 mm) from the innermost elements of the side rails. It shall be arranged across the tray with a minimum of  $\frac{3}{8}$ " (10 mm) between stacks so that the loading material does not bridge transversely. All loading material shall be placed between the supports without overhanging.

## NEMA STANDARDS

For loading weight in a ladder-type tray, it shall be permissible to cover the bottom of the tray between supports with a flat sheet of No. 9 gauge (3.8 mm) flattened expanded material not more than 3' (900 mm) long and with a wire hole size of 3/4" (19 mm), or a flat sheet of No. 16 gauge (1.5 mm) sheet steel not more than 3' (900 mm) long. The expanded metal or sheet steel shall not be fastened to the tray and shall be no closer than 1/2" (13 mm) to the side rails. The 3' (900 mm) lengths shall not overlap by more than 2" (50 mm). The weight of the expanded metal or sheet steel shall be added to the total weight of the loading material.

### 4.1.7 Destruction Load Capacity

The total weight of the loading material on the cable tray at the time it is destroyed less the last incremental weight added shall be considered to be the destruction load capacity of the cable tray. The Rated Load Capacity shall be the Destruction Load Capacity divided by a safety factor of 1.5.

### 4.1.8 Interpolation & Extrapolation of Test Data

When allowable load and deflection data are determined by load tests, values for span lengths not tested shall be determined by interpolation from a curve based on values for a minimum of the two (2) span lengths. Extrapolation for shorter span lengths is permissible using the formula below, however extrapolation shall not be used for span lengths longer than the longest span length tested.

Where:  $W2 = (W1 \times L12) / L22$

$W1 =$  Tested Load, lbs/ft (kg/m)

$W2 =$  Load on Shorter Span, lbs/ft (kg/m)

$L1 =$  Tested Span Length, ft (m)

$L2 =$  Shorter Span Length, ft (m)

### 4.2 RESIDUAL DEFLECTION TEST

Determine the Minimum Test Load (MTL) from the formula:

Where:  $MTL = 1.5 * L * W$

1.5 = Safety Factor

L = Span Length, ft (m)

W = Rated Load at Span Length, lbs/ft (kg/m)

A minimum of two (2) tray specimens shall be tested. The following procedure shall be used for each tray.

1. Load tray to 10% of MTL. Measure the vertical deflection of the tray at two (2) points along the line midway between the supports and at right angles to the longitudinal axis of the tray. The two points shall be at the midpoint of the span and under of each side rail. The two readings shall be considered to be the initial deflection of the tray.
2. Continue loading until the Rated Load (W) has been applied. Measure the deflection at the same points as for the initial deflection measurement above.

3. Continue loading until the Minimum Test Load (MTL) has been applied. Remove the all load from the tray and wait 15 minutes before measuring the deflection at the previous two points. This final measurement is known as the residual deflection of the tray specimen.

Average the residual deflections of the two (2) test specimens. This shall be considered the final result. However, if the residual deflection for either specimen is > 80% of the initial deflection, and in addition, deviates from the average by more than 10%, then two more specimens shall be tested. The average of the three highest values at the point of measurement of the four specimens shall be considered the final result.

### 4.3 ELECTRICAL CONTINUITY OF CONNECTIONS

#### 4.3.1 Test Specimen

Each specimen shall consist of two 24" (600 mm) lengths of side rail connected by the manufactures standard splice.

#### 4.3.2 Resistance Test Procedure

Each specimen should be joined together, using the mechanical connector, and following the instructions provided by the manufacturer.

A current of 30 amperes DC shall be passed through the specimen and the resistance measured between two points 1/16" (1.6 mm) from each side of the splice. The net resistance of the joint shall be not more than 0.00033 ohm as computed from the measured voltage drop and the current passing through the specimen. The ambient temperature of the specimen shall be between 60° and 90°F (15° to 35°C). The current shall be applied to the specimen at least 12" (300 mm) from the splice joint.

## SECTION 5 - SPECIFICATIONS & DRAWINGS

### 5.1 DATA TO APPEAR IN SPECIFICATIONS

The following statement and minimum data, when applicable, should appear in all cable tray specifications:

Cable tray shall be manufactured and installed in accordance with NEMA Standard VE 1-2017

Load / Support Span Class Designation (see Table 1) Type (see Section 1.2 Definitions)

Material (see Section 2.1)

Finish (see Section 2.2)

Tray Length (see Section 2.3)

Width (see Section 2.3)

Inside Depth (see Section 2.3)

Rung Spacing (see Section 2.3)

Fitting Radius (see Section 2.3).

## NEMA STANDARDS

### 5.2 DATA TO APPEAR ON DRAWINGS

The following minimum data should appear on all cable tray drawings:

- Type (ladder, trof, etc.)
- Width(s)
- Load depth
- Straight section, fitting, or accessory
- Fitting radii
- Elevation (bottom of tray)
- Vertical and horizontal changes in direction
- Clearances-vertical and horizontal
- Number of trays (if there is a stack of trays)
- Support span
- Show graphic scale

## SECTION 6 - APPLICATION INFORMATION

### 6.1 DEFLECTION

Under normal applications deflection limitations should not be included in design criteria for cable trays. However, if unusual or special conditions exist, the manufacturer should be consulted. Limitations of deflection for aesthetic purpose only can result in an over-designed tray system.

### 6.2 CONCENTRATED STATIC LOAD (If Required by User)

A concentrated static load is not included in the Load/Span Designations NEMA VE-1, Table 1. Some user applications may require that a given concentrated static load be imposed over and above the working load.

Such a concentrated static load represents a static weight applied between the side rails at midspan. When so specified, the concentrated static load may be converted to an equivalent, uniform load ( $W_e$ ) in pounds per linear foot (kilograms per meter) using the formula: (see NEMA VE-2, Section 4.8.2)

$$W_e = 2 \times \frac{\text{(Concentrated Static Load)}}{\text{span length, ft. (m)}}$$

The value for  $W_e$  will be added to the static weight of cables in the tray. This combined load may be used to select the appropriate load/span designation NEMA VE-1, Table 1. If the combined load exceeds the working load shown in the load/span designation table, the manufacturer should be consulted.

### 6.3 WARNING! WALKWAYS

Inasmuch as cable tray is designed as a support for power or control cables, or both, and is not intended or designed to be a walkway for personnel, the user is urged to display appropriate warnings cautioning against the use of this support as a walkway. The following language is suggested:

**Warning! Not to be used as a walkway, ladder or support for personnel. To be used only as a mechanical support for cables and tubing.**

### 6.4 FITTINGS

Changes in direction should be mechanically continuous and accomplished by use of fittings having dimensions in accordance with 2.5.

### 6.5 SUPPORTS

Supports for cable trays should provide strength and working load capacity sufficient to meet the load requirement of the cable tray systems.

Horizontal and vertical tray supports should provide an adequate bearing surface for the tray and should have provisions for hold down clamps or fasteners.

In addition, vertical tray supports should provide secured means for fastening cable trays to supports.

### 6.6 SUPPORT LOCATIONS

**For complete information on cable tray support, please refer to NEMA Standard VE-2-2006.**

#### 6.6.1 Horizontal Cable Tray Straight Sections

Horizontal cable tray straight sections should be supported at intervals not to exceed the support span for the appropriate NEMA Class Designation shown in NEMA VE-1, Table 1. Un-spliced straight sections should be used on all simple spans and on end spans of continuous span runs. A support should be located within 2' (610mm) of each side of an expansion connector. Straight section lengths should be equal to or greater than the span length to ensure not more than one splice between supports.

#### 6.6.2 Horizontal Cable Tray Fittings

1. Horizontal Elbow Supports for horizontal tray fittings should be placed within 2' (600 mm) of each fitting extremity, and as follows: (See page 22, Figure 6-1 for a graphic presentation of fitting supports.)
  - (a) 90° supports at the 45° point of arc.
  - (b) 60° supports at the 30° point of arc.
  - (c) 45° supports at the 22½° point of arc (except for the 12" (300 mm) radii).
  - (d) 30° supports at the 15° point of arc (except for the 12" (300 mm) radii).
2. Horizontal Tee Supports shall be placed within 2' (600 mm) of each of the three openings connected to other cable tray items for 12" (300 mm) radius fittings. On all other radii, at least one support should be placed under each side rail of the horizontal tee, preferably as shown in Figure 6-2, page 22.

## NEMA STANDARDS

3. Horizontal Cross Supports shall be placed within 2' (600 mm) of each of the four openings connected to other cable tray items for 12" (300 mm) radius fittings. On all other radii, at least one support should be placed under each side rail of the horizontal cross, preferably as shown in Figure 6-3, page 22.
4. Horizontal Wye Supports shall be placed within 2' of each of the three openings connected to other cable tray items, and at 22½° point of the arc adjacent to the branch as shown in Figure 6-4, page 22.
5. Reducer Supports shall be placed within 2' (600 mm) of each fitting extremity as shown in Figure 6-5 and 6-6, page 22.
6. Vertical Cable Tray Elbows should be supported at the top of runs at each end of the fitting. Vertical cable tray elbows at the bottom of runs should be supported at the top of the elbow and within 2' (600 mm) of the lower extremity of the elbow as shown in Figure 6-7, page 22.
7. Vertical Cable Tray Tees should be supported within 2' (600 mm) of each fitting extremity as shown in Figure 6-8, page 22.

### 6.6.3 Vertical Straight Sections

Vertical straight sections should be supported indoors at appropriate intervals permitted by the building structure; outdoor support intervals should be determined by wind loading. The maximum distance between vertical supports should not exceed 24' (7,320 mm) on centers.

### 6.6.4 Sloping Trays

Sloping trays should be supported at intervals not exceeding those for horizontal trays of the same design for the same installation.

### 6.6.5 Fittings as End of Run

A fitting which is used as an end of the run dropout should have a support attached to it, firmly reinforcing the fitting.

### 6.7 PROTECTION OF CABLE INSULATION

The inside of cable tray systems should present no sharp edges, burrs, or projections which could damage cable insulation.

### 6.8 THERMAL CONTRACTION AND EXPANSION

It is important that thermal contraction and expansion be considered when installing cable tray systems. If it is determined that expansion connectors are required, reference should be made to table on page 19 for maximum spacing between supports and to the table on page 19 to determine the proper splice plate setting.

The cable tray should be securely fixed at the support nearest to its midpoint between the expansion connectors and secured by expansion guides at all other support locations. The cable tray should be permitted longitudinal movement in both directions from that fixed point towards the expansion connectors.

Accurate gap setting at the time of installation is necessary for the proper operation of the expansion connectors. The following procedure should assist the installer in determining the correct gap:

**Step 1** - Plot the highest expected cable tray metal temperature on the maximum temperature vertical axis. Example's Value = 100°F. (See page 19).

**Step 2** - Plot the lowest expected cable tray metal temperature on the minimum temperature vertical axis. Example's Value = -28° F.

**Step 3** - Draw a line between these maximum and minimum temperature points on the two vertical axis.

**Step 4** - To determine the required expansion joint gap setting: Plot the cable tray metal temperature at the time of the cable tray installation on the Maximum temperature vertical axis. (Example's Value = 50° F).

Project over from the 50°F point on the maximum temperature vertical axis to an intersection with the line between the maximum and minimum cable tray metal temperatures. From this intersection point, project down to the gap setting horizontal axis to find the correct gap setting value (Example's Value: 3/8" gap setting). This is the length of the gap to be set between the cable tray sections at the expansion joint splice plate location.

**NOTE: THE MAXIMUM GAP SPACE BETWEEN TRAY SECTIONS IS 1" (25 MM).**

### 6.9 CABLE INSTALLATION

When installing cable in cable tray, it is important that care and planning be exercised so that the cable or the cable tray is not damaged or destroyed. The cable manufacturer should be contacted for maximum pulling tensions and minimum bending radii, and advice on prevention of "egging" or deformation of cable jacketing or shielding.

### NEMA CLASS

The NEMA Classifications for Cable Tray were established to simplify and standardize the specification of Cable Tray. This classification is based on the working load (the total weight of the cables) and the support span (the distance between supports). The NEMA VE1 specifications are contained in Section 2.

### Cable Load/Working Load

The Cable Load or the working load is the total weight of the cables to be placed in the tray. The NEMA classes are based on cable loads of 50#, 75#, and 100# per Lineal Foot. This is the total weight of cables in the tray. For purposes of selecting a suitable tray, this weight should be rounded off to the next higher NEMA working (allowable) load.

### Support Spans

Support span is the distance between the supports. The NEMA standard support spans are based on 8', 12', 16' and 20'.

### NEMA Classes

The following table summarizes the NEMA classes based on cable/working load and support span described previously.

| NEMA Load/Span Designations |                   |                              |
|-----------------------------|-------------------|------------------------------|
| Class Designation           | Support Span Feet | Working Load Lbs./Linear Ft. |
| 8A                          | 8                 | 50                           |
| 8B                          | 8                 | 75                           |
| 8C                          | 8                 | 100                          |
| 12A                         | 12                | 50                           |
| 12B                         | 12                | 75                           |
| 12C                         | 12                | 100                          |
| 16A                         | 16                | 50                           |
| 16B                         | 16                | 75                           |
| 16C                         | 16                | 100                          |
| 20A                         | 20                | 50                           |
| 20B                         | 20                | 75                           |
| 20C                         | 20                | 100                          |

To determine what NEMA load class is required for your project, refer to the National Electrical Code® (NEC®). Determine type of cable and the appropriate cable tray type based on NEC® Article 392 guidelines. Establish the number and type of cables required in each cable tray run; then calculate the total number of square inches of cable in the run. Using NEC®, Article 392.9, Tables 392.9(A), 392.9(C), 392.9(E), 392.9(F), and 392.10(A), determine the allowable cable fill for the type of cable tray and cable being used. The number of square inches of installed cable divided by the allowable cable fill percentage will determine the size of the cable tray needed.

Calculated the total weight of cables (in pounds per linear foot) to be installed in the cable tray. Determine the frequency of cable tray supports (span). **Example:** Project requires 50 multiple conductor cables in a tray. The cable is .5" in diameter and weighs .3 pounds per foot. The tray selected is a ventilated bottom trough tray and will be supported every 12 feet. **Tray Size Calculation:** Area =  $3.14 \times .252 = 0.19625$  sq. in. per cable. 50 cables multiplied by .019625 sq. in. = 9.8125 total sq inches of cable. 9.8125 sq. in. divided by .5 (% fill allowed) = 19.625 sq. in. minimum needed within the tray. Divide 19.625 sq. in. by 4" (load depth of a tray) = 4.9" wide tray minimum. The closest standard tray is a 4" Load Depth x 6" Wide. **Weight Calculation:** 50 cables multiplied by .3 pounds per foot = 15 pounds per foot of cable. Select a NEMA 12A rated tray which will hold 50 pounds of weight when supported every 12 feet.

### OTHER LOADING CONSIDERATIONS

It is important to note that when specifying loading requirements, there are other loading factors that may need to be considered over and above the actual cable loads.

### Destruction Load Capacity

The total weight in the tray which causes the tray to collapse is called the "destruction load capacity". When trays do collapse, they generally do so by premature lateral buckling (compression) of the top flange.



### Concentrated Loads

A concentrated load is a static weight applied between the side rails at mid span. When specified, these concentrated static loads may be converted to an equivalent uniform load ( $W_e$ ), in pounds per lineal foot, using the following formula:

$$W_e = \frac{2 * \text{Concentrated Load}}{\text{Support Span}}$$

This load ( $W_e$ ) is then added to the static weight of the cable before selecting the appropriate NEMA load span designation.

Please note per the NEMA VE-1 guidelines all AB-Cope Cable Trays are labeled as follows:

|  |  |   |
|--|--|---|
|  | <b>WARNING!</b>  |   |
|  | DO NOT USE AS A WALKWAY, LADDER OR SUPPORT FOR PERSONNEL. TO BE USED ONLY AS A MECHANICAL SUPPORT FOR CABLES AND TUBING. |   |
| ORDER NO. C26074<br>PART NUMBER<br><b>1B48-06SL-12-09</b>                            | LINE 4   | P.O. NO. 574311WW<br>NEMA VE-1/FG-1 LOAD CLASS 12B                                    |
| STR. LGTH LDR AL 4"LD 06" W 12"L 09 RS   |  |   |
| MINIMUM CROSS SECTION AREA .60 SQ. IN  |  | CABLE TRAY<br>6316  |
| *TORQUE 3/8" DIAMETER HARDWARE TO 20 FT.-LBS.*                                       |  |  |

## OVERVIEW

### ENVIRONMENTAL LOAD CONSIDERATIONS

Environmental loads should be considered in any outdoor installation, particularly when cable tray is to be covered. These loads include wind loads, snow loads, and ice loads. Specific information data concerning these loads can be obtained by contacting the Cope Factory. Other sources for this type of information can be obtained through the local weather bureau.

It is important to note that these types of loads need to be considered in terms of pounds per square feet, unlike the cable loads, which are calculated in terms of pounds per linear foot.

The following are general guidelines to follow:

- **Wind Loads**  
75 m.p.h. wind = 25 lbs./sq. ft. pressure
- **Ice Loads**  
1/2" thick ice on tray surfaces weighs 2.4 lbs/sq. ft.
- **Snow Loads**  
Snow loads vary greatly depending on the latitude and altitude at the job site. Contact local weather bureau for information.

### SAFETY FACTOR

All loads stated in the Cope Selection Charts have a 1.5 safety factor, in accordance with the NEMA VE-1 Guidelines. A safety factor is the reserve strength, above the actual cable loading, for which a tray system was designed.

#### Conversion of Safety factor from 1.5 to 2.0

The loads stated in the Selection Charts have a safety factor of 1.5 per the NEMA VE-1 guidelines. To convert the load carrying capabilities, as listed in these charts, to a 2.0 safety factor, multiply the stated loads by 0.75.

#### Testing Methods

Loading data stated in the catalog has been derived from actual testing of the tray systems, or by means of structural calculations. These figures were based on Simple Beam calculation, per the NEMA VE-1 guidelines.

When tray is supported as a simple beam, the load causes bending moments all along the beam resulting in deflection, called sag, inducing stress in the beam. The material above the longitudinal center line (neutral axis) is compressed. Material below is stretched and is in tension. The maximum stress in a simple beam is at the center of the span. Failure of cable tray will occur in compression before tension. This is why tray rails often have stiffened top flanges.

A simple beam is present when a single straight section of tray is supported on each end. When a series of straight sections are connected and supported by more than one support it is referred to as a continuous beam. The NEMA VE-1 Standards consider only simple beams for testing purposes, due to the following reasons:

1. It requires maximum properties for a given load and support spacing.
2. It is easiest to approximate by calculation.
3. It represents the most severe or worst case loading.
4. Destruction load capacities can be easily verified.

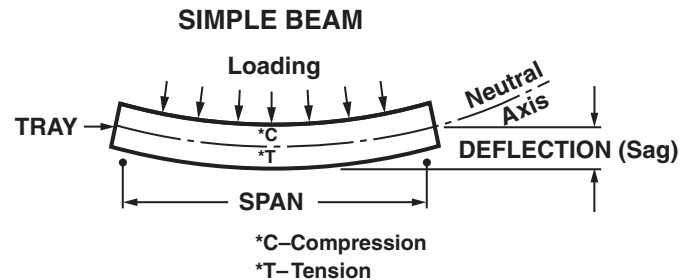

### DEFLECTION VS. ECONOMY

Cable tray that meets all performance and dimensional criteria with the safety factor specified without regard for deflection is the most economical tray for the installation. When deflection limitations are imposed, a less economical tray system may result. We recommend that deflection limitations should be imposed in only the most stringent situations. If deflection is a concern, we recommend these maximum limits for the optimum design.

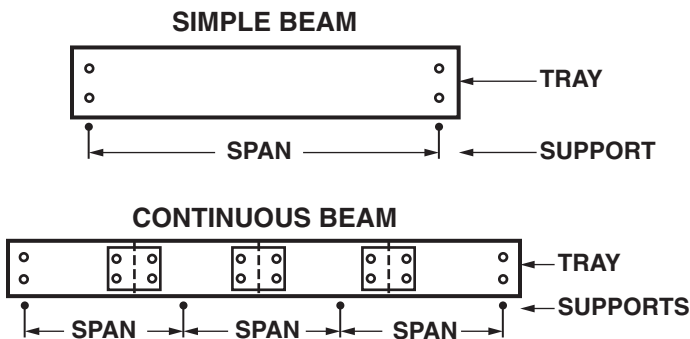

|          | Simple Beam Span |      |
|----------|------------------|------|
|          | 12'              | 20'  |
| STEEL    | 1/100            | 1/75 |
| ALUMINUM | 1/75             | 1/50 |

### CAVITY SIZE - LOAD DEPTH/WIDTH OF TRAY

The size of the cable tray cavity is determined specifically by the electrical requirements and by the specific cables being used to meet those requirements.

Article 392 of the National Electrical Code® lists the specific requirements concerning allowable Cable Fill. It is imperative that the size of the cavity meets the conditions set forth by the NEC®, specifically:

- Types of cables allowed in which type of cable trays
- Requirements for arranging the cables in the trays.

The NEC® breaks down the allowable cable fill into three main categories:

- **Multi-Conductor:** The number of multi-conductor cables rated at 2000 volts or less in cable tray.
- **Single conductor:** The number of single conductor cables rated at 2000 volts or less in cable tray.
- **MV and MC Cables:** The number of MV & MC cables rated at 2001 volts or over in the cable tray.

Cable fill guidelines set forth by the NEC® are generally based on limiting heat build up in the trays. Where data or communications type cables are being installed, heat is not a critical issue and the allowable fill is determined by the total cross sectional area of the tray cavity:

$$\text{Total Cross Sectional Area} = (\text{Width}) \times (\text{Load Depth}).$$

### LENGTH OF STRAIGHT SECTIONS

AB-Cope Cable Tray is available in 12' and 24' lengths in accordance with the NEMA Standards. It is also available in 10' and 20' lengths in accordance with CSA Standards. Customized lengths are also available upon request.

The following factors need to be considered when specifying the lengths of the tray:

**Support Span** – The support span should not be greater than the tray length. This ensures that two splice plate connections will not fall within one support span.

**Space Constraints** – When installing trays in a limited space, as often encountered in commercial applications, 10' and 12' lengths of tray are easier to handle and therefore are better suited for those applications.

**Labor Costs** – Where trays are being installed in an industrial facility, where space is not as significant an issue, handling 20' and 24' lengths may be more economical. In this instance, half as many tray connections need to be made. Additionally, if the proper tray system is specified, support spans may be lengthened.

### RADIUS OF FITTINGS

Cable tray fittings are used to change directions both horizontally and vertically. The standard radii for cable tray fittings are 12", 24", and 36".

The radius of the fittings should be based upon minimum bending radius of the cables. This information can be obtained from the cable manufacturer.

Based on the total number of cables to be placed in the tray, it may be more practical to use the next higher radius.

### CABLE TRAY SUPPORT LOCATIONS

#### Straight Sections

A general rule of thumb is that the splice plates should not fall beyond the 1/4 point of the span, or the distance between supports. For example: On a 20' support span the splice plates should not be further than 5' away from the support location.

Under no circumstances should two cable tray splices fall between any pair of supports.

For special applications, mid-span splice plates can be furnished. Please contact the factory.

#### Fittings

Supports for cable tray elbows are critical. It is important to note that the cable tray will come under its greatest stress when cables are being pulled into the tray. Therefore, proper placement of supports is necessary to insure that the integrity of the tray system is maintained during the cable pulling operation.

The diagrams on page 22 shows the recommended support locations for fittings.

#### Thermal Expansion and Contraction

It is important to use expansion connectors when installing long runs of cable tray. The number of expansion connectors required will depend on:

- (1) the maximum temperature differential
- (2) the tray material being installed

AB-Cope Expansion Connectors allow 1" of travel. This table illustrates how often expansion splice plates must be used.

| Temperature Difference | Dist. Between Expansion Joints |            |             |
|------------------------|--------------------------------|------------|-------------|
|                        | Steel                          | Aluminum   | Copper      |
| 25°F (14°C)            | 512' (156m)                    | 260' (79m) | 363' (111m) |
| 50°F (28°C)            | 256' (78m)                     | 130' (40m) | 182' (55m)  |
| 75°F (42°C)            | 171' (52m)                     | 87' (27m)  | 121' (37m)  |
| 100°F (56°C)           | 128' (39m)                     | 65' (20m)  | 90' (27m)   |
| 125°F (70°C)           | 102' (31m)                     | 52' (16m)  | 72' (22m)   |
| 150°F (83°C)           | 85' (26m)                      | 43' (13m)  | 60' (18m)   |
| 175°F (97°C)           | 73' (22m)                      | 37' (11m)  | 52' (16m)   |

## OVERVIEW

The following table is used to determine the proper gap setting between trays. The metal temperature determines the proper gap setting at the time of installation. Establish maximum and minimum temperatures in summer and winter for the area. Draw a line connecting them. Using the metal temperature at time of installation (C° or F°) draw horizontal to temperature slope and plot straight down to find gap distance at expansion joint.

The following diagram illustrates the proper installation of an expansion system.

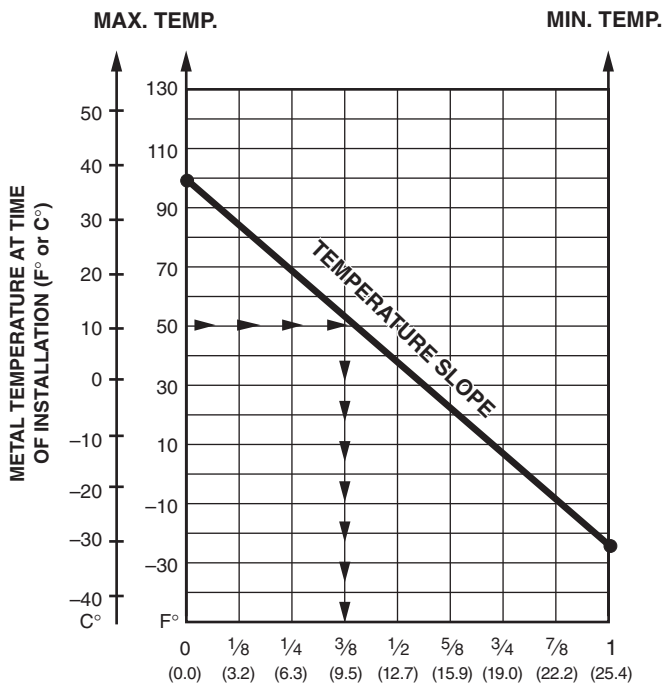

It is important to note that grounding straps are required when expansion connections are made. This will insure proper grounding continuity.

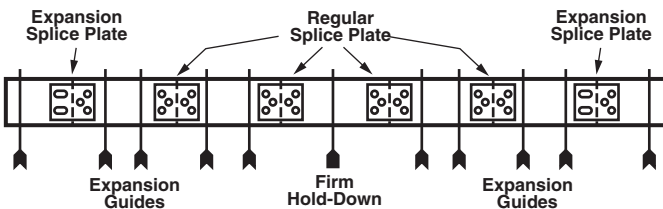

## ELECTRICAL GROUNDING

The National Electrical Code®, Article 392-7 allows for Cable Tray to be used as an equipment grounding conductor in commercial and industrial establishments. The following table lists specific ampere ratings and the minimum cross sectional area requirements for each rating.

AB-COPE produces trays that meet the National Electrical Code® (ANSI/NFPA 70), are classified by Underwriters Lab oratories, Inc. (UL) as equipment ground conductors. These can be used for any project worldwide except where another standard may take precedence, such as the Canadian Standards Association.

For projects requiring adherence to the Canadian Standards Association (CSA), Cope products as shown in the CSA Selection Charts, pages 35-36, and 143-144 are certified as complying with CSA C22.2 No. 0 and No. 126 and will bear the CSA Mark as shown below.

AB-COPE SA. CO. LTD  
STREET NO. 136, 2ND  
INDUSTRIAL CITY  
DAMMAM KSA

6D57 TYPE 1  
CLASS E  
97 Kg/m

C22.2 No 126

When required, the trays can be installed per the Canadian Electrical Code Parts I and II (CEC). Cope trays and splice plates meet the bonding requirements of the CSA Standards and the CEC.

| Max. Fuse Amp Rating<br>Circuit Breaker Amp Trip Setting<br>or Relay Amp Trip Setting<br>for Ground Fault Protection<br>of any Cable Tray Circuit<br>In the Cable Tray system | Minimum<br>Cross<br>Sectional Area<br>of Metal* Steel<br>Cable Trays |                 | Aluminum<br>Cable Trays |                 |
|---|--|-----------------|-------------------------|-----------------|
|   | In <sup>2</sup>  | mm <sup>2</sup> | In <sup>2</sup>         | mm <sup>2</sup> |
| 60  | 0.2  | 129             | 0.2                     | 129             |
| 100   | 0.4  | 258             | 0.2                     | 129             |
| 200   | 0.7  | 452             | 0.2                     | 129             |
| 400   | 1  | 645             | 0.4                     | 258             |
| 600   | 1.50**   | 968             | 0.4                     | 258             |
| 1,000   | -  | -               | 0.6                     | 387             |
| 1,200   | -  | -               | 1                       | 645             |
| 1,600   | -  | -               | 1.5                     | 968             |
| 2,000   | -  | -               | 2.00**                  | 1,290           |

\* Total cross sectional area of both side rails for ladder and trof type trays, or the minimum cross sectional area for metal in channel type cable trays or cable trays of one piece construction.

\*\* Steel cable trays shall not be used as equipment grounding conductors for circuits with ground-fault protection above 600 amperes. Aluminum cable trays shall not be used as equipment grounding conductors for circuits with ground-fault protection above 2000 amperes.

AB-Cope CSA steel designs are offered in Type 1 (HDGAF) finish and aluminum with plain finish. Available are ladder, vented, and solid bottom cable Trofs for 3 meter spans and ladder type for 6 meter spans.

The cross-sectional area for each AB-Cope Cable Tray system, straight sections and fittings, can be found on the appropriate AB-Cope Selection charts contained within this publication. In addition all AB-Cope Cable Tray, straight sections and fittings, are supplied with pressure sensitive labels indicating the cross sectional area of both side rails, as required by the (NEC®) National Electrical Code®, Article 392.

### Bonding Jumpers / Straps

Cable Tray connections made with AB-Cope's standard rigid splice plates do not exceed .00033 ohms net resistance, and are compliance in Underwriters Laboratories Classification Program. These rigid type connections do not require electrical bonding straps.

Electrical bonding straps are required where cable trays are joined by connectors which allow for movement, such as vertical adjustable connectors, horizontal adjustable connectors, and expansion connectors.

Proper grounding is also necessary where cable trays run parallel to each other, are stacked upon one another, and in other instances, where tray runs are discontinuous.

Further questions concerning grounding issues should be directed to AB-Cope SA. Co. Ltd.

### SUMMARY

You are now ready to select the best AB-Cope Cable Tray system to meet your needs. By now, we hope you've decided to select the system using the NEMA CLASSIFICATION (8A, 12B, 20C, etc.) which makes your work so much easier. Selection is also possible using physical dimensions, performance, or any combination of these data listed in our exclusive NEMA oriented AB-Cope selection charts. As always, should you need additional information, we suggest you contact your nearest AB-Cope Representative or call AB-Cope SA. Co. Ltd directly.

#### NEC® Articles

| Description | 2002 and Later Editions | 1999 & Prior Editions |
|-------------|-------------------------|-----------------------|
| Cable Trays | 392                     | 318                   |

## SUPPORT LOCATIONS FOR FITTINGS

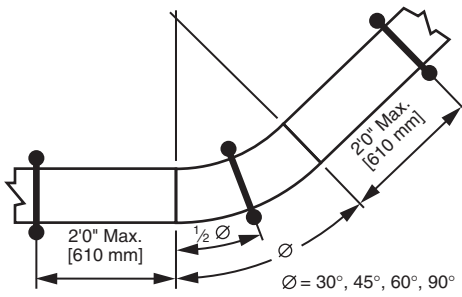

**Figure 6-1**  
**HORIZONTAL ELBOWS**

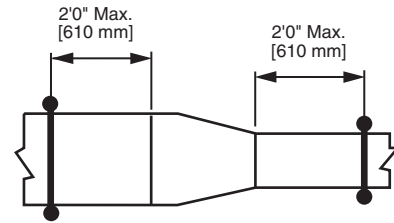

**Figure 6-5**  
**STRAIGHT REDUCER**

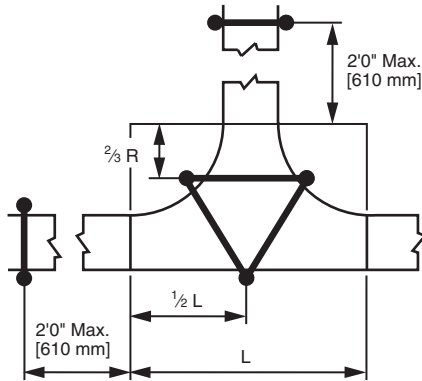

**Figure 6-2**  
**HORIZONTAL TEE**

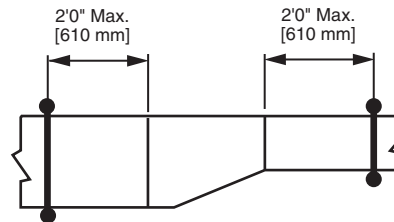

**Figure 6-6**  
**OFFSET REDUCER**

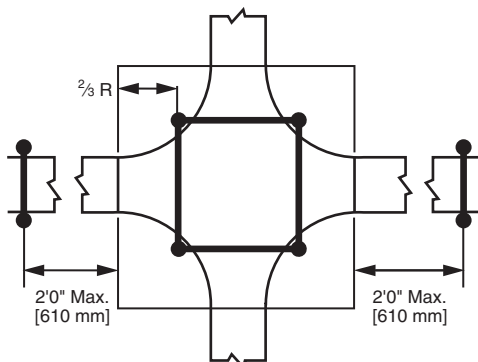

**Figure 6-3**  
**HORIZONTAL CROSS**

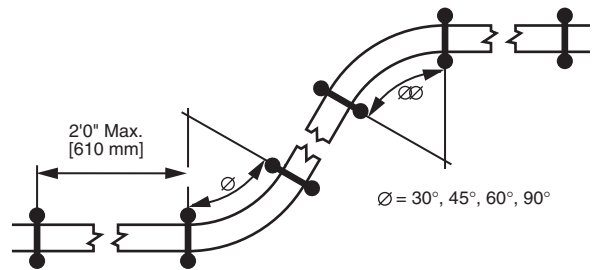

**Figure 6-7**  
**VERTICAL ELBOWS**

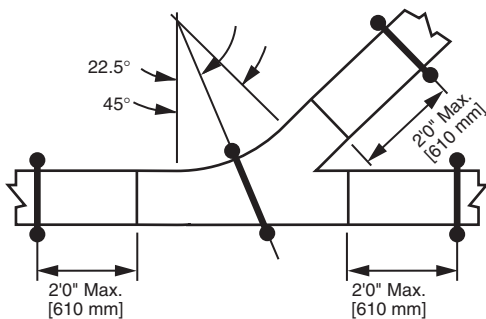

**Figure 6-4**  
**HORIZONTAL WYE**

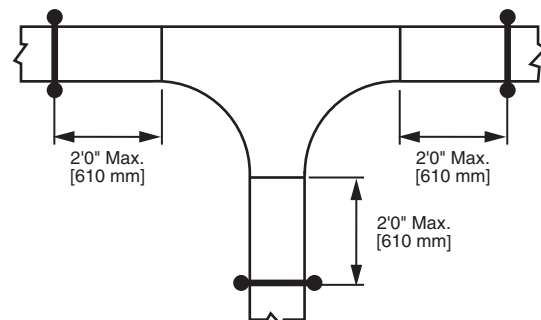

**Figure 6-8**  
**VERTICAL TEE**



# AB-COPE LADDER

# 3



**Cable Ladder System for Power, Control,  
Instrumentation Cable & Pneumatic Tubing**

## CONTENTS

### General & Technical Information

|   |         |
|---|---------|
| Selection Chart: AB-Cope Ladder - Aluminum..... | 27 - 28 |
| Selection Chart: AB-Cope Ladder - Steel .....   | 29 - 30 |
| Overview .....                                  | 31 - 32 |
| Ordering Information .....                      | 33      |
| Straight Length .....                           | 34      |
| CSA Ordering Information .....                  | 35      |
| CSA Selection Chart: Aluminum/Steel .....       | 36      |

### AB-Cope Ladder Fittings

|                                       |         |
|---------------------------------------|---------|
| Horizontal Elbows                     |         |
| 90° & 60° .....                       | 37      |
| 45° & 30° .....                       | 38      |
| Horizontal Tee .....                  | 39      |
| Horizontal Cross .....                | 40      |
| Horizontal Tapped Tee.....            | 41 - 42 |
| Horizontal Tapped Cross .....         | 43 - 44 |
| Left and Right Hand Reducers .....    | 45      |
| Straight Reducers.....                | 46      |
| Adjustable Elbow.....                 | 47      |
| 45° "Y" Branch.....                   | 47      |
| Vertical Elbows (Inside and Outside)  |         |
| 90° & 60° .....                       | 48      |
| 45° & 30° .....                       | 49      |
| 90° Vertical Cable Support Elbow..... | 50      |
| Vertical Tee .....                    | 50      |

### Connectors & Hardware

|   |    |
|---|----|
| Universal Curvilinear Connector, Expansion, Mid Span Splice Plate |    |
| Horiz. and Vert. Adjustable, Reducing and 90° Connector .....     | 51 |
| General Hardware.....   | 52 |

### Covers

|  |    |
|--|----|
| Covers.....  | 53 |
| Cover Attachments (Hold down clamps,<br>elevated and peaked cover connectors)..... | 54 |

### Accessories

|   |         |
|---|---------|
| Blind End, Drop Out, Bonding Jumper, Box Connector                          |         |
| Cable Tray Ground Clamp, Ground Cable Retainer Clamp .....                  | 55      |
| Conduit Clamp, Wall Sleeve .....  | 56      |
| Barrier Strips and Barrier Strip Clamps.....                                | 57      |
| Hold Down Clamp and Expansion Guide, Cable Clamp,<br>Seismic Hold Down..... | 58      |
| Support Brackets.....   | 59 - 60 |
| Tray Hangers, Tray Brackets .....   | 60      |
| Hanger Support, Trapeze Hanger Support .....                                | 61      |

### Specification Information

|                                  |    |
|----------------------------------|----|
| Electrical Grounding Chart ..... | 62 |
| Typical Specification .....      | 62 |
| Suggested Fittings .....         | 63 |

**Straight Length**

Page 34

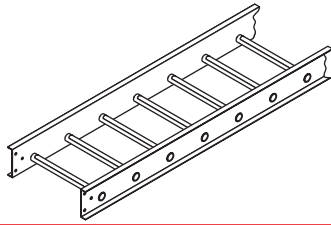

**Horizontal Elbows**

Pages 37 - 38

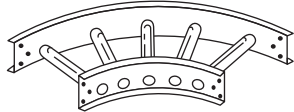

**Horizontal Tee & Cross**

Pages 39 - 40

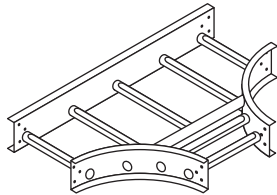

**Horizontal Tapped Tee & Cross**

Pages 41 - 44

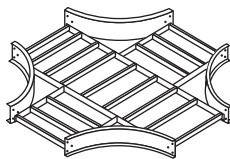

**Reducers**

Pages 45 - 46

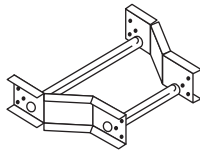

**Adjustable Elbows**

Page 47

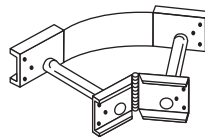

**45° "Y" Branch**

Page 47

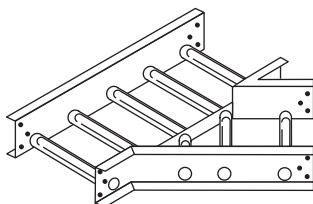

**Vertical Elbows**

Pages 48 - 49

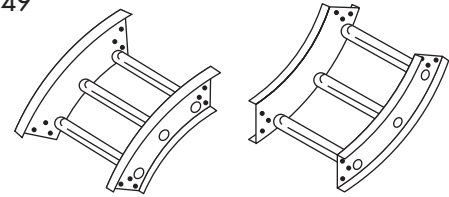

**90° Vertical Cable Support Elbow**

Page 50

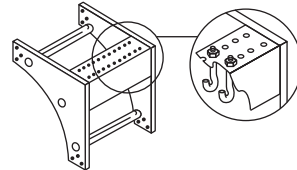

**Vertical Tee**

Page 50

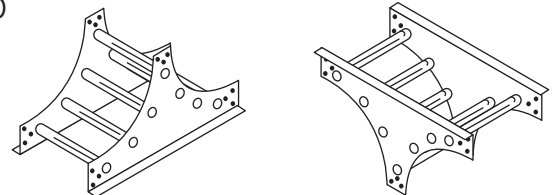

**Covers**

Page 53

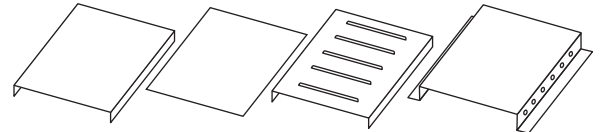

**Cover Attachments**

Page 54



**Connectors**

Page 55

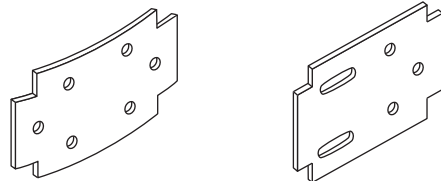

**Barrier Strips & Accessories**

Pages 57

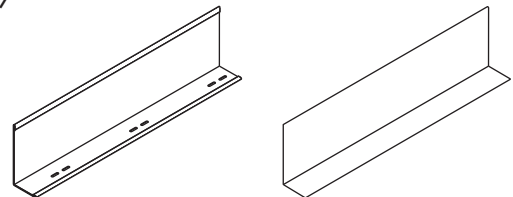

# SELECTION CHART COPE LADDER - ALUMINUM

## NEMA CLASS, PHYSICAL AND STRUCTURAL PROPERTIES

| NEMA Class<br>(See<br>NEMA VE-1<br>Table 3-1)                                | NEMA<br>Load/Span                       | Cope<br>System<br>Number | Actual<br>Load<br>Depth<br>in. (mm) | Side<br>Rail<br>Height<br>in. (mm) | Flange<br>Width<br>(in.) | Section<br>Modulus<br>S <sub>x</sub><br>(in. <sup>3</sup> ) | Moment<br>of<br>Inertia<br>I <sub>x</sub><br>(in. <sup>4</sup> ) | Min X-Sect.<br>Area of 2<br>Rails per<br>NEC 318-7<br>(sq. in.) |
|--|---|--------------------------|-------------------------------------|------------------------------------|--------------------------|---|--|---|
| <b>8A</b>  | <b>8 = 8'-0"</b><br><b>Load lb./ft.</b> | 1238                     | 3 (76)                              | 4 1/4 (108)                        | 13/16                    | .367  | .780   | .60   |
|  |   | 1B48                     | 4 (102)                             | 5 1/4 (133)                        | 13/16                    | .571  | 1.436  | .60   |
|  |   | 3B58                     | 5 (127)                             | 6 1/4 (159)                        | 13/16                    | .807  | 2.360  | 1.00  |
|  |   | 1B68                     | 6 (152)                             | 7 1/4 (184)                        | 13/16                    | .937  | 3.284  | 1.00  |
| <b>8B</b>  | <b>A = 50</b>                           |                          |                                     |                                    |                          |   |  |   |
|  |   |                          |                                     |                                    |                          |   |  |   |
|  |   |                          |                                     |                                    |                          |   |  |   |
|  |   |                          |                                     |                                    |                          |   |  |   |
| <b>8C</b>  | <b>B = 75</b>                           |                          |                                     |                                    |                          |   |  |   |
|  |   |                          |                                     |                                    |                          |   |  |   |
|  |   |                          |                                     |                                    |                          |   |  |   |
|  |   |                          |                                     |                                    |                          |   |  |   |
| <b>12A</b>   | <b>50 lb./ft.</b><br><b>12' span</b>    | 1B38                     | 3 (76)                              | 4 1/4 (108)                        | 13/16                    | .449  | .911   | .60   |
|  |   | 1B48                     | 4 (102)                             | 5 1/4 (133)                        | 13/16                    | .571  | 1.436  | .60   |
|  |   | 3B58                     | 5 (127)                             | 6 1/4 (159)                        | 13/16                    | .807  | 2.360  | 1.00  |
|  |   | 1B68                     | 6 (152)                             | 7 1/4 (184)                        | 13/16                    | .937  | 3.284  | 1.00  |
| <b>12B</b>   | <b>75 lb./ft</b><br><b>12' span</b>     | 3B38                     | 3 (76)                              | 4 1/4 (108)                        | 13/16                    | .574  | .158   | .60   |
|  |   | 1B48                     | 4 (102)                             | 5 1/4 (133)                        | 13/16                    | .571  | 1.436  | .60   |
|  |   | 3B58                     | 5 (127)                             | 6 1/4 (159)                        | 13/16                    | .807  | 2.360  | 1.00  |
|  |   | 1B68                     | 6 (152)                             | 7 1/4 (184)                        | 13/16                    | .937  | 3.284  | 1.00  |
| <b>12C</b>   | <b>100 lb./ft.</b><br><b>12' span</b>   | 5B38                     | 3 (76)                              | 4 1/4 (108)                        | 13/16                    | .751  | 1.529  | 1.00  |
|  |   | 3B48                     | 4 (102)                             | 5 1/4 (133)                        | 13/16                    | .761  | 1.867  | 1.00  |
|  |   | 3B58                     | 5 (127)                             | 6 1/4 (159)                        | 13/16                    | .972  | 2.933  | 1.00  |
|  |   | 5B68                     | 6 (152)                             | 7 1/4 (184)                        | 13/16                    | 1.288   | 4.516  | 1.00  |
| <b>16A</b>   | <b>50 lb./ft.</b><br><b>16' span</b>    | 5B38                     | 3 (76)                              | 4 1/4 (108)                        | 13/16                    | .823  | 1.675  | 1.00  |
|  |   | 5448                     | 4 (102)                             | 5 1/4 (133)                        | 1 1/4                    | 1.040   | 2.731  | 1.50  |
|  |   | 3458                     | 5 (127)                             | 6 1/4 (159)                        | 1 1/4                    | 1.091   | 3.409  | 1.00  |
|  |   | 3468                     | 6 (152)                             | 7 1/4 (184)                        | 1 1/4                    | 1.365   | 4.946  | 1.50  |
| <b>16B</b>   | <b>75 lb./ft.</b><br><b>16' span</b>    | 3D38                     | 3 (76)                              | 4 1/4 (108)                        | 1 1/4                    | 1.121   | 2.203  | 1.50  |
|  |   | 7448                     | 4 (102)                             | 5 1/4 (133)                        | 1 1/4                    | 1.198   | 3.146  | 1.50  |
|  |   | 1D58                     | 5 (127)                             | 6 1/4 (159)                        | 1 1/4                    | 1.189   | 3.601  | 1.00  |
|  |   | 1568                     | 6 (152)                             | 7 1/4 (184)                        | 1 1/2                    | 1.506   | 5.461  | 1.50  |
| <b>16C</b>   | <b>100 lb./ft.</b><br><b>16' span</b>   | 5D38                     | 3 (76)                              | 4 1/4 (108)                        | 1 1/4                    | 1.391   | 2.869  | 1.50  |
|  |   | 3D48                     | 4 (102)                             | 5 1/4 (133)                        | 1 1/4                    | 1.717   | 4.373  | 2.00  |
|  |   | 3658                     | 5 (127)                             | 6 1/4 (159)                        | 1 3/4                    | 1.745   | 5.453  | 1.50  |
|  |   | 1E68                     | 6 (152)                             | 7 1/4 (184)                        | 1 1/2                    | 1.626   | 5.726  | 1.50  |
| <b>20A</b>   | <b>50 lb./ft.</b><br><b>20' span</b>    | 3D38                     | 3 (76)                              | 4 1/4 (108)                        | 1 1/4                    | 1.121   | 2.203  | 1.50  |
|  |   | 7448                     | 4 (102)                             | 5 1/4 (133)                        | 1 1/4                    | 1.198   | 3.146  | 1.50  |
|  |   | 1D58                     | 5 (127)                             | 6 1/4 (159)                        | 1 1/4                    | 1.189   | 3.601  | 1.00  |
|  |   | 1E68                     | 6 (152)                             | 7 1/4 (184)                        | 1 1/2                    | 1.626   | 5.726  | 1.50  |
| <b>20B</b>   | <b>75 lb./ft.</b><br><b>20' span</b>    | 3E38                     | 3 (76)                              | 4 1/4 (108)                        | 1 1/2                    | 1.649   | 3.418  | 2.00  |
|  |   | 3D48                     | 4 (102)                             | 5 1/4 (133)                        | 1 1/4                    | 1.717   | 4.373  | 2.00  |
|  |   | 3658                     | 5 (127)                             | 6 1/4 (159)                        | 1 3/4                    | 1.745   | 5.453  | 1.50  |
|  |   | 1E68                     | 6 (152)                             | 7 1/4 (184)                        | 1 1/2                    | 1.626   | 5.726  | 1.50  |
| <b>20C</b>   | <b>100 lb./ft.</b><br><b>20' span</b>   | 5E38                     | 3 (76)                              | 4 1/4 (108)                        | 1 1/2                    | 1.858   | 3.879  | 2.00  |
|  |   | 5D48                     | 4 (102)                             | 5 1/4 (133)                        | 1 1/4                    | 1.955   | 5.010  | 2.00  |
|  |   | 5F58                     | 5 (127)                             | 6 1/4 (159)                        | 1 3/4                    | 2.115   | 5.982  | 2.00  |
|  |   | 3G68                     | 6 (152)                             | 7 1/4 (184)                        | 2                        | 2.243   | 7.851  | 2.00  |
| <i>OTHER ECONOMICAL SYSTEMS AVAILABLE DUE TO HIGH DEMAND</i>                 |   |                          |                                     |                                    |                          |   |  |   |
| <b>NEMA CLASS</b><br><b>8A thru 12A</b>                                      |   | 1248                     | 4 (102)                             | 5 1/4 (133)                        | 13/16                    | .507  | 1.331  | .60   |
|  |   | 1258                     | 5 (127)                             | 6 1/4 (159)                        | 13/16                    | .667  | 2.086  | .60   |
|  |   | 1268                     | 6 (152)                             | 7 1/4 (184)                        | 13/16                    | .848  | 3.072  | 1.00  |
| <b>8A thru 16C</b><br><b>8A thru 20B</b>                                     |   | 1F58                     | 5 (127)                             | 6 1/4 (159)                        | 1 3/4                    | 1.431   | 4.292  | 1.00  |
|  |   | 7D58                     | 5 (127)                             | 6 1/4 (159)                        | 1 1/4                    | 1.957   | 5.952  | 2.00  |
| <i>EXTRA HEAVY DUTY - VERY LONG SPAN TRAYS - 6", 9", OR 12" RUNG SPACING</i> |   |                          |                                     |                                    |                          |   |  |   |
| <b>20C PLUS</b>  |   | 9D58                     | 5 (127)                             | 6 1/4 (159)                        | 1 1/4                    | 2.565   | 7.850  | 2.00  |
|  |   | 7G58                     | 5 (127)                             | 6 1/4 (159)                        | 2                        | 2.902   | 8.728  | 2.00  |

Indicates most common systems

Note : Metric equivalent in ( )

w = Pounds per linear foot  
 Metric: for kg/m multiply w by 1:48  
 d = Deflection (inches)  
 k = Deflection (in.) for each pound of load  
 + = Denotes k is less than .001 inch

### LOAD AND DEFLECTION DATA FOR ALUMINUM LADDER

| Cope System Number | Working (Allowable) Load Capacity - Evenly Distributed<br>Span (Ft.) - Simple Beam - <b>SAFETY FACTOR: 1.5</b> |     |      |         |     |      |          |      |      |          |      |      |          |      |      |          |      |      |          |      |      |          |      |      |
|--------------------|--|-----|------|---------|-----|------|----------|------|------|----------|------|------|----------|------|------|----------|------|------|----------|------|------|----------|------|------|
|                    | 6 (1.8)  |     |      | 8 (2.4) |     |      | 10 (3.1) |      |      | 12 (3.7) |      |      | 16 (4.9) |      |      | 20 (6.1) |      |      | 24 (7.3) |      |      | 25 (7.6) |      |      |
|                    | w  | d   | k    | w       | d   | k    | w        | d    | k    | w        | d    | k    | w        | d    | k    | w        | d    | k    | w        | d    | k    | w        | d    | k    |
| 1238               | 181  | .34 | .002 | 102     | .60 | .006 | 65       | .94  | .014 | 45       | 1.36 | .030 |          |      |      |          |      |      |          |      |      |          |      |      |
| 1B48               | 324  | .33 | .001 | 182     | .59 | .003 | 117      | .87  | .007 | 77       | 1.26 | .016 |          |      |      |          |      |      |          |      |      |          |      |      |
| 3B58               | 359  | .22 | +    | 191     | .37 | .002 | 115      | .55  | .005 | 75       | .74  | .010 |          |      |      |          |      |      |          |      |      |          |      |      |
| 1B68               | 416  | .18 | +    | 221     | .31 | .001 | 133      | .46  | .003 | 87       | .62  | .007 |          |      |      |          |      |      |          |      |      |          |      |      |
| 1B38               | 222  | .35 | .002 | 125     | .63 | .005 | 80       | .99  | .012 | 55       | 1.42 | .026 |          |      |      |          |      |      |          |      |      |          |      |      |
| 1B48               | 324  | .33 | .001 | 182     | .59 | .003 | 117      | .87  | .007 | 77       | 1.26 | .016 |          |      |      |          |      |      |          |      |      |          |      |      |
| 3B58               | 359  | .22 | +    | 191     | .37 | .002 | 115      | .55  | .005 | 75       | .74  | .010 |          |      |      |          |      |      |          |      |      |          |      |      |
| 1B68               | 416  | .18 | +    | 221     | .31 | .001 | 133      | .46  | .003 | 87       | .62  | .007 |          |      |      |          |      |      |          |      |      |          |      |      |
| 3B38               | 354  | .45 | .001 | 191     | .76 | .004 | 117      | 1.14 | .010 | 78       | 1.57 | .020 |          |      |      |          |      |      |          |      |      |          |      |      |
| 1B48               | 324  | .33 | .001 | 182     | .59 | .003 | 117      | .87  | .007 | 77       | 1.26 | .016 |          |      |      |          |      |      |          |      |      |          |      |      |
| 3B58               | 359  | .22 | +    | 191     | .37 | .002 | 115      | .55  | .005 | 75       | .74  | .010 |          |      |      |          |      |      |          |      |      |          |      |      |
| 1B68               | 416  | .18 | +    | 221     | .31 | .001 | 133      | .46  | .003 | 87       | .62  | .007 |          |      |      |          |      |      |          |      |      |          |      |      |
| 5B38               | 448  | .39 | +    | 251     | .69 | .003 | 161      | 1.08 | .007 | 112      | 1.55 | .014 |          |      |      |          |      |      |          |      |      |          |      |      |
| 3B48               | 394  | .31 | +    | 222     | .55 | .002 | 142      | .86  | .006 | 100      | 1.24 | .012 |          |      |      |          |      |      |          |      |      |          |      |      |
| 3B58               | 480  | .24 | +    | 257     | .40 | .002 | 156      | .60  | .004 | 102      | .81  | .008 |          |      |      |          |      |      |          |      |      |          |      |      |
| 5B68               | 540  | .17 | +    | 286     | .29 | .001 | 172      | .43  | .003 | 111      | .57  | .005 |          |      |      |          |      |      |          |      |      |          |      |      |
| 5B38               |  |     |      | 251     | .69 | .003 | 161      | 1.08 | .007 | 112      | 1.55 | .014 | 51       | 2.26 | .044 | 25       | 2.75 | .110 |          |      |      |          |      |      |
| 5448               |  |     |      | 260     | .44 | .002 | 166      | .69  | .004 | 96       | .82  | .009 | 51       | 1.36 | .027 | 28       | 1.83 | .065 |          |      |      |          |      |      |
| 3458               |  |     |      | 273     | .37 | .001 | 155      | .51  | .003 | 101      | .69  | .007 | 51       | 1.10 | .022 | 24       | 1.28 | .053 |          |      |      |          |      |      |
| 3468               |  |     |      | 284     | .26 | +    | 182      | .41  | .002 | 110      | .52  | .005 | 52       | .78  | .015 | 30       | 1.10 | .037 |          |      |      |          |      |      |
| 3D38               |  |     |      | 342     | .72 | .002 | 219      | 1.12 | .005 | 152      | 1.61 | .011 | 82       | 2.74 | .033 | 52       | 4.27 | .082 |          |      |      |          |      |      |
| 7448               |  |     |      | 349     | .51 | .001 | 223      | .80  | .004 | 155      | 1.15 | .007 | 79       | 1.85 | .023 | 51       | 2.89 | .057 |          |      |      |          |      |      |
| 1D58               |  |     |      | 380     | .49 | .001 | 222      | .69  | .003 | 154      | 1.00 | .006 | 78       | 1.61 | .021 | 50       | 2.51 | .050 |          |      |      |          |      |      |
| 1568               |  |     |      | 377     | .32 | +    | 241      | .50  | .002 | 149      | .64  | .004 | 78       | 1.06 | .014 | 50       | 1.65 | .033 |          |      |      |          |      |      |
| 5D38               |  |     |      | 444     | .71 | .002 | 284      | .70  | .002 | 188      | 1.53 | .008 | 106      | 2.73 | .026 | 65       | 4.07 | .063 |          |      |      |          |      |      |
| 3D48               |  |     |      | 525     | .55 | .001 | 336      | .86  | .003 | 233      | 1.24 | .005 | 119      | 2.01 | .017 | 76       | 3.14 | .041 |          |      |      |          |      |      |
| 3658               |  |     |      | 481     | .41 | +    | 308      | .64  | .002 | 215      | .92  | .004 | 121      | 1.63 | .013 | 77       | 2.55 | .033 |          |      |      |          |      |      |
| 1E68               |  |     |      | 542     | .44 | +    | 318      | .62  | .002 | 221      | .90  | .004 | 119      | 1.53 | .013 | 76       | 2.39 | .032 |          |      |      |          |      |      |
| 3D38               |  |     |      |         |     |      |          |      |      | 152      | 1.61 | .011 | 82       | 2.74 | .033 | 52       | 4.27 | .082 |          |      |      |          |      |      |
| 7448               |  |     |      |         |     |      |          |      |      | 155      | 1.51 | .007 | 79       | 1.85 | .023 | 51       | 2.89 | .057 |          |      |      |          |      |      |
| 1D58               |  |     |      |         |     |      |          |      |      | 154      | 1.00 | .006 | 78       | 1.61 | .021 | 50       | 2.51 | .050 |          |      |      |          |      |      |
| 1E68               |  |     |      |         |     |      |          |      |      | 221      | .90  | .004 | 119      | 1.53 | .013 | 76       | 2.39 | .032 |          |      |      |          |      |      |
| 3E38               |  |     |      |         |     |      |          |      |      | 224      | 1.53 | .007 | 120      | 2.59 | .022 | 77       | 4.05 | .053 |          |      |      |          |      |      |
| 3D48               |  |     |      |         |     |      |          |      |      | 233      | 1.24 | .005 | 119      | 2.01 | .017 | 76       | 3.14 | .041 |          |      |      |          |      |      |
| 3658               |  |     |      |         |     |      |          |      |      | 215      | .92  | .004 | 121      | 1.63 | .013 | 77       | 2.55 | .033 |          |      |      |          |      |      |
| 1E68               |  |     |      |         |     |      |          |      |      | 221      | .90  | .004 | 119      | 1.53 | .013 | 76       | 2.39 | .032 |          |      |      |          |      |      |
| 5E38               |  |     |      |         |     |      |          |      |      | 298      | 1.79 | .006 | 161      | 3.07 | .019 | 103      | 4.79 | .047 |          |      |      |          |      |      |
| 5D48               |  |     |      |         |     |      |          |      |      | 290      | 1.35 | .005 | 156      | 2.30 | .015 | 100      | 3.59 | .036 |          |      |      |          |      |      |
| 5F58               |  |     |      |         |     |      |          |      |      | 316      | 1.23 | .004 | 178      | 2.19 | .012 | 114      | 3.43 | .030 |          |      |      |          |      |      |
| 3G68               |  |     |      |         |     |      |          |      |      | 313      | .93  | .003 | 176      | 1.66 | .009 | 113      | 2.59 | .023 |          |      |      |          |      |      |
| 1248               | 251  | .27 | .001 | 141     | .49 | .003 | 90       | .76  | .008 | 63       | 1.10 | .017 |          |      |      |          |      |      |          |      |      |          |      |      |
| 1258               | 264  | .18 | +    | 148     | .33 | .002 | 83       | .46  | .005 | 58       | .64  | .011 |          |      |      |          |      |      |          |      |      |          |      |      |
| 1268               | 335  | .16 | +    | 177     | .27 | .001 | 106      | .40  | .003 | 63       | .48  | .007 |          |      |      |          |      |      |          |      |      |          |      |      |
| 1F58               |  |     |      | 400     | .43 | .001 | 256      | .67  | .003 | 177      | .97  | .005 | 100      | 1.72 | .017 |          |      |      |          |      |      |          |      |      |
| 7D58               |  |     |      |         |     |      | 364      | .43  | .001 | 252      | .99  | .003 | 142      | 1.76 | .012 | 91       | 2.75 | .030 |          |      |      |          |      |      |
| 9D58               |  |     |      |         |     |      |          |      |      | 412      | 1.22 | .003 | 214      | 2.00 | .009 | 131      | 3.01 | .023 | 68       | 3.23 | .048 |          |      |      |
| 7G58               |  |     |      |         |     |      |          |      |      | 451      | 1.20 | .003 | 253      | 2.14 | .008 | 162      | 3.35 | .020 | 112      | 4.79 | .043 | 104      | 5.24 | .050 |

Note : To convert 1.5 safety factor to 2.0, multiply w, d, k, by .75.  
 : Metric equivalent in ( ).

# SELECTION CHART COPE LADDER - STEEL

| NEMA CLASS, PHYSICAL AND STRUCTURAL PROPERTIES   |                           |                     |                            |                           |                    |  |  |   |       |
|--|---------------------------|---------------------|----------------------------|---------------------------|--------------------|--|--|---|-------|
| NEMA Class<br>(See NEMA VE-1 Table 3-1)  | NEMA Load/Span            | HDGAF System Number | Actual Load Depth in. (mm) | Side Rail Height in. (mm) | Flange Width (in.) | Section Modulus Sx (in. <sup>3</sup> ) | Moment of Inertia Ix (in. <sup>4</sup> ) | Min X-Sect. Area of 2 Rails per NEC 318-7 (sq. in.) |       |
| <b>8A</b>  | 8 = 8'-0"<br>Load lb./ft. | 8237                | 3 (76)                     | 4¼ (108)                  | 13/16              | .296                                   | .629                                     | .40   |       |
|  |                           | 8247                | 4 (102)                    | 5¼ (133)                  | 13/16              | .408                                   | 1.071                                    | .40   |       |
|  |                           | <b>8B</b>           | 8257                       | 5 (127)                   | 6¼ (159)           | 13/16                                  | .536                                     | 1.676   | .70   |
|  |                           |                     | <b>8C</b>                  | 8267                      | 6 (152)            | 7¼ (184)                               | 13/16                                    | .680  | 2.466 |
| <b>12A</b>   | 50 lb./ft.<br>12' span    | 8237                | 3 (76)                     | 4¼ (108)                  | 13/16              | .296                                   | .629                                     | .40   |       |
|  |                           | 8247                | 4 (102)                    | 5¼ (133)                  | 13/16              | .408                                   | 1.071                                    | .40   |       |
|  |                           | 8257                | 5 (127)                    | 6¼ (159)                  | 13/16              | .536                                   | 1.676                                    | .70   |       |
|  |                           | 8B67                | 6 (152)                    | 7¼ (184)                  | 13/16              | .680                                   | 2.466                                    | .70   |       |
| <b>12B</b>   | 75 lb./ft.<br>12' span    | 8B37                | 3 (76)                     | 4¼ (108)                  | 13/16              | .339                                   | .685                                     | .40   |       |
|  |                           | 8247                | 4 (102)                    | 5¼ (133)                  | 13/16              | .408                                   | 1.071                                    | .40   |       |
|  |                           | 8257                | 5 (127)                    | 6¼ (159)                  | 13/16              | .536                                   | 1.676                                    | .70   |       |
|  |                           | 8B67                | 6 (152)                    | 7¼ (184)                  | 13/16              | .787                                   | 2.758                                    | .70   |       |
| <b>12C</b>   | 100 lb./ft.<br>12' span   | 6B37                | 3 (76)                     | 4¼ (108)                  | 13/16              | .417                                   | .845                                     | .70   |       |
|  |                           | 8B47                | 4 (102)                    | 5¼ (133)                  | 13/16              | .462                                   | 1.162                                    | .40   |       |
|  |                           | 6257                | 5 (127)                    | 6¼ (159)                  | 13/16              | .665                                   | 2.079                                    | .70   |       |
|  |                           | 8B67                | 6 (152)                    | 7¼ (184)                  | 13/16              | .787                                   | 2.758                                    | .70   |       |
| <b>16A</b>   | 50 lb./ft.<br>16' span    | 8D37                | 3 (76)                     | 4¼ (108)                  | 1¼                 | .426                                   | .868                                     | .40   |       |
|  |                           | 8D47                | 4 (102)                    | 5¼ (133)                  | 1¼                 | .573                                   | 1.447                                    | .70   |       |
|  |                           | 8457                | 5 (127)                    | 6¼ (159)                  | 1¼                 | .665                                   | 2.078                                    | .70   |       |
|  |                           | 8467                | 6 (152)                    | 7¼ (184)                  | 1¼                 | .830                                   | 3.008                                    | .70   |       |
| <b>16B</b>   | 75 lb./ft.<br>16' span    | 6D37                | 3 (76)                     | 4¼ (108)                  | 1¼                 | .528                                   | 1.076                                    | .70   |       |
|  |                           | 8D47                | 4 (102)                    | 5¼ (133)                  | 1¼                 | .573                                   | 1.447                                    | .70   |       |
|  |                           | 8D57                | 5 (127)                    | 6¼ (159)                  | 1¼                 | .730                                   | 2.206                                    | .70   |       |
|  |                           | 8467                | 6 (152)                    | 7¼ (184)                  | 1¼                 | .830                                   | 3.008                                    | .70   |       |
| <b>16C</b>   | 100 lb./ft.<br>16' span   | 4D37                | 3 (76)                     | 4¼ (108)                  | 1¼                 | .649                                   | 1.326                                    | 1.00  |       |
|  |                           | 6447                | 4 (102)                    | 5¼ (133)                  | 1¼                 | .640                                   | 1.680                                    | .70   |       |
|  |                           | 6457                | 5 (127)                    | 6¼ (159)                  | 1¼                 | .826                                   | 2.580                                    | 1.00  |       |
|  |                           | 8D67                | 6 (152)                    | 7¼ (184)                  | 1¼                 | .907                                   | 3.185                                    | .70   |       |
| <b>20A</b>   | 50 lb./ft.<br>20' span    | 6D37                | 3 (76)                     | 4¼ (108)                  | 1¼                 | .528                                   | 1.076                                    | .70   |       |
|  |                           | 6447                | 4 (102)                    | 5¼ (133)                  | 1¼                 | .640                                   | 1.680                                    | .70   |       |
|  |                           | 6457                | 5 (127)                    | 6¼ (159)                  | 1¼                 | .826                                   | 2.580                                    | 1.00  |       |
|  |                           | 6467                | 6 (152)                    | 7¼ (184)                  | 1¼                 | 1.031                                  | 3.739                                    | 1.00  |       |
| <b>20B</b>   | 75 lb./ft.<br>20' span    | 4E37                | 3 (76)                     | 4¼ (108)                  | 1¼                 | .725                                   | 1.484                                    | 1.00  |       |
|  |                           | 4D47                | 4 (102)                    | 5¼ (133)                  | 1¼                 | .872                                   | 2.209                                    | 1.00  |       |
|  |                           | 6D57                | 5 (127)                    | 6¼ (159)                  | 1¼                 | .907                                   | 2.743                                    | 1.00  |       |
|  |                           | 6D67                | 6 (152)                    | 7¼ (184)                  | 1¼                 | 1.123                                  | 3.951                                    | 1.00  |       |
| <b>20C</b>   | 100 lb./ft.<br>20' span   | 2E37                | 3 (76)                     | 4¼ (108)                  | 1¼                 | .983                                   | 2.020                                    | 1.50  |       |
|  |                           | 4E47                | 4 (102)                    | 5¼ (133)                  | 1¼                 | .965                                   | 2.451                                    | 1.00  |       |
|  |                           | 4D57                | 5 (127)                    | 6¼ (159)                  | 1¼                 | 1.120                                  | 3.389                                    | 1.00  |       |
|  |                           | 4467                | 6 (152)                    | 7¼ (184)                  | 1¼                 | 1.278                                  | 4.632                                    | 1.00  |       |
| <i>THESE COPE SYSTEMS ARE NOT LISTED ABOVE BUT REMAIN AVAILABLE DUE TO HIGH DEMAND</i> |                           |                     |                            |                           |                    |  |  |   |       |
| 8A, B, C; 12A, B, C  |                           | 4B37                | 3 (76)                     | 4¼ (108)                  | 13/16              | .512                                   | 1.039                                    | .70   |       |
| 8A, B, C; 12A, B, C  |                           | 6B47                | 4 (102)                    | 5¼ (133)                  | 13/16              | .570                                   | 1.436                                    | .70   |       |
| 8A, B, C; 12A, B, C; 16A   |                           | 4B47                | 4 (102)                    | 5¼ (133)                  | 13/16              | .701                                   | 1.769                                    | 1.00  |       |
| All Except 20C   |                           | 2D37                | 3 (76)                     | 4¼ (108)                  | 1¼                 | .879                                   | 1.802                                    | 1.00  |       |
| All Classes  |                           | 2D47                | 4 (102)                    | 5¼ (133)                  | 1¼                 | 1.185                                  | 3.013                                    | 1.50  |       |
| All Classes  |                           | 2D57                | 5 (127)                    | 6¼ (159)                  | 1¼                 | 1.526                                  | 4.635                                    | 1.50  |       |
| <i>EXTRA HEAVY DUTY - VERY LONG SPAN TRAYS - 6", 9", OR 12" RUNG SPACING</i>           |                           |                     |                            |                           |                    |  |  |   |       |
| <b>20C PLUS</b>  |                           | 11D57               | 5 (127)                    | 6¼ (159)                  | 1¼                 | 1.768                                  | 5.315                                    | 1.50  |       |

Indicates most common systems

Note: Metric equivalent in ( ).

W = Pounds per linear foot  
 Metric: for kg/m multiply w by 1.48  
 d = Deflection (inches)  
 k = Deflection (in.) for each pound of load  
 † = Denotes k is less than .001 inch

### LOAD AND DEFLECTION DATA FOR STEEL LADDER

| Cope System Number | Working (Allowable) Load Capacity - Evenly Distributed<br>Span (Ft.) — Simple Beam — <b>SAFETY FACTOR: 1.5</b> |     |   |         |     |      |          |     |      |          |      |      |          |      |      |          |      |      |          |      |      |          |      |      |
|--------------------|--|-----|---|---------|-----|------|----------|-----|------|----------|------|------|----------|------|------|----------|------|------|----------|------|------|----------|------|------|
|                    | 6 (1.8)  |     |   | 8 (2.4) |     |      | 10 (3.1) |     |      | 12 (3.7) |      |      | 16 (4.9) |      |      | 20 (6.1) |      |      | 24 (7.3) |      |      | 25 (7.6) |      |      |
|                    | w  | d   | k | w       | d   | k    | w        | d   | k    | w        | d    | k    | w        | d    | k    | w        | d    | k    | w        | d    | k    | w        | d    | k    |
| 8236/8237          | 292  | .23 | † | 164     | .42 | .003 | 103      | .63 | .006 | 69       | .89  | .013 |          |      |      |          |      |      |          |      |      |          |      |      |
| 8246/8247          | 383  | .18 | † | 210     | .31 | .001 | 127      | .46 | .004 | 83       | .62  | .007 |          |      |      |          |      |      |          |      |      |          |      |      |
| 8256/8257          | 357  | .11 | † | 194     | .18 | †    | 119      | .28 | .002 | 79       | .38  | .005 |          |      |      |          |      |      |          |      |      |          |      |      |
| 8266/8267          | 420  | .09 | † | 227     | .16 | †    | 139      | .22 | .002 | 92       | .30  | .003 |          |      |      |          |      |      |          |      |      |          |      |      |
| 8236/8237          | 292  | .23 | † | 164     | .42 | .003 | 103      | .63 | .006 | 69       | .89  | .013 |          |      |      |          |      |      |          |      |      |          |      |      |
| 8246/8247          | 383  | .18 | † | 210     | .31 | .001 | 127      | .46 | .004 | 83       | .62  | .007 |          |      |      |          |      |      |          |      |      |          |      |      |
| 8256/8257          | 357  | .11 | † | 194     | .18 | †    | 119      | .28 | .002 | 79       | .38  | .005 |          |      |      |          |      |      |          |      |      |          |      |      |
| 8266/8267          | 420  | .09 | † | 227     | .16 | †    | 139      | .22 | .002 | 92       | .30  | .003 |          |      |      |          |      |      |          |      |      |          |      |      |
| 8B36/8B37          | 360  | .26 | † | 198     | .46 | .002 | 124      | .70 | .006 | 84       | .98  | .012 |          |      |      |          |      |      |          |      |      |          |      |      |
| 8246/8247          | 383  | .18 | † | 210     | .31 | .001 | 127      | .46 | .004 | 83       | .62  | .007 |          |      |      |          |      |      |          |      |      |          |      |      |
| 8256/8257          | 357  | .11 | † | 194     | .18 | †    | 119      | .28 | .002 | 79       | .38  | .005 |          |      |      |          |      |      |          |      |      |          |      |      |
| 8B66/8B67          | 680  | .12 | † | 328     | .19 | †    | 182      | .26 | .001 | 107      | .31  | .003 |          |      |      |          |      |      |          |      |      |          |      |      |
| 6B36/6B37          | 453  | .27 | † | 249     | .47 | .002 | 156      | .71 | .005 | 106      | 1.00 | .009 |          |      |      |          |      |      |          |      |      |          |      |      |
| 8B46/8B47          | 456  | .20 | † | 244     | .33 | .001 | 152      | .51 | .003 | 103      | .71  | .007 |          |      |      |          |      |      |          |      |      |          |      |      |
| 6256/6257          | 460  | .11 | † | 250     | .19 | †    | 154      | .29 | .002 | 103      | .40  | .004 |          |      |      |          |      |      |          |      |      |          |      |      |
| 8B66/8B67          | 680  | .12 | † | 328     | .19 | †    | 182      | .26 | .001 | 107      | .31  | .003 |          |      |      |          |      |      |          |      |      |          |      |      |
| 8D36/8D37          |  |     |   | 290     | .53 | .002 | 182      | .81 | .004 | 126      | 1.17 | .009 | 65       | 1.91 | .029 |          |      |      |          |      |      |          |      |      |
| 8D46/8D47          |  |     |   | 382     | .42 | .001 | 245      | .66 | .003 | 170      | .94  | .006 | 86       | 1.54 | .018 |          |      |      |          |      |      |          |      |      |
| 8456/8457          |  |     |   | 268     | .20 | †    | 166      | .31 | .002 | 111      | .43  | .004 | 58       | .71  | .012 |          |      |      |          |      |      |          |      |      |
| 8466/8467          |  |     |   | 322     | .17 | †    | 199      | .26 | .001 | 133      | .36  | .003 | 69       | .58  | .008 |          |      |      |          |      |      |          |      |      |
| 6D36/6D37          |  |     |   | 381     | .56 | .001 | 244      | .88 | .004 | 169      | 1.27 | .008 | 88       | 2.08 | .024 |          |      |      |          |      |      |          |      |      |
| 8D46/8D47          |  |     |   | 382     | .42 | .001 | 245      | .66 | .003 | 170      | .94  | .006 | 86       | 1.54 | .018 |          |      |      |          |      |      |          |      |      |
| 8D56/8D57          |  |     |   | 426     | .31 | †    | 259      | .46 | .002 | 171      | .62  | .004 | 86       | .99  | .012 |          |      |      |          |      |      |          |      |      |
| 8466/8467          |  |     |   | 322     | .17 | †    | 199      | .26 | .001 | 133      | .36  | .003 | 75       | .63  | .008 |          |      |      |          |      |      |          |      |      |
| 4D36/4D37          |  |     |   | 487     | .58 | .001 | 312      | .91 | .003 | 216      | 1.31 | .006 | 113      | 2.16 | .019 |          |      |      |          |      |      |          |      |      |
| 6446/6447          |  |     |   | 444     | .42 | †    | 273      | .63 | .002 | 186      | .89  | .005 | 100      | 1.51 | .015 |          |      |      |          |      |      |          |      |      |
| 6456/6457          |  |     |   | 574     | .35 | †    | 367      | .55 | .001 | 245      | .76  | .003 | 123      | 1.22 | .010 |          |      |      |          |      |      |          |      |      |
| 8D66/8D67          |  |     |   | 504     | .25 | †    | 306      | .37 | .001 | 202      | .51  | .003 | 101      | .80  | .008 |          |      |      |          |      |      |          |      |      |
| 6D36/6D37          |  |     |   |         |     |      |          |     |      | 169      | 1.27 | .008 | 88       | 2.08 | .024 | 52       | 2.98 | .057 |          |      |      |          |      |      |
| 6446/6447          |  |     |   |         |     |      |          |     |      | 186      | .89  | .005 | 100      | 1.51 | .015 | 53       | 1.94 | .037 |          |      |      |          |      |      |
| 6456/6457          |  |     |   |         |     |      |          |     |      | 245      | .76  | .003 | 123      | 1.22 | .010 | 66       | 1.59 | .024 |          |      |      |          |      |      |
| 6466/6467          |  |     |   |         |     |      |          |     |      | 178      | .38  | .002 | 93       | .62  | .007 | 55       | .91  | .017 |          |      |      |          |      |      |
| 4E36/4E37          |  |     |   |         |     |      |          |     |      | 251      | 1.36 | .005 | 131      | 2.24 | .017 | 77       | 3.23 | .042 |          |      |      |          |      |      |
| 4D46/4D47          |  |     |   |         |     |      |          |     |      | 280      | 1.02 | .004 | 145      | 1.67 | .012 | 85       | 2.40 | .028 |          |      |      |          |      |      |
| 4D56/4D57          |  |     |   |         |     |      |          |     |      | 269      | .80  | .003 | 139      | 1.28 | .009 | 81       | 1.82 | .022 |          |      |      |          |      |      |
| 6D66/6D67          |  |     |   |         |     |      |          |     |      | 291      | .59  | .002 | 148      | .95  | .006 | 85       | 1.33 | .016 |          |      |      |          |      |      |
| 2E36/2E37          |  |     |   |         |     |      |          |     |      | 316      | 1.26 | .004 | 164      | 2.06 | .013 | 100      | 3.09 | .013 |          |      |      |          |      |      |
| 4E46/4E47          |  |     |   |         |     |      |          |     |      | 304      | 1.00 | .003 | 157      | 1.63 | .010 | 100      | 2.50 | .025 |          |      |      |          |      |      |
| 4D56/4D57          |  |     |   |         |     |      |          |     |      | 296      | .79  | .003 | 152      | 1.28 | .008 | 105      | 1.91 | .018 |          |      |      |          |      |      |
| 4466/4467          |  |     |   |         |     |      |          |     |      | 379      | .66  | .002 | 191      | 1.05 | .005 | 102      | 1.37 | .013 |          |      |      |          |      |      |
| 4B36/4B37          | 569  | .28 | † | 313     | .48 | .002 | 196      | .73 | .004 | 133      | 1.03 | .008 |          |      |      |          |      |      |          |      |      |          |      |      |
| 6B46/6B47          | 591  | .21 | † | 325     | .36 | .001 | 203      | .55 | .003 | 137      | .77  | .006 |          |      |      |          |      |      |          |      |      |          |      |      |
| 4B46/4B47          | 779  | .22 | † | 428     | .38 | †    | 268      | .59 | .002 | 182      | .83  | .005 |          |      |      |          |      |      |          |      |      |          |      |      |
| 2D36/2D37          |  |     |   |         |     |      | 438      | .94 | .002 | 304      | 1.36 | .004 | 159      | 2.24 | .014 | 94       | 3.23 | .034 |          |      |      |          |      |      |
| 2D46/2D47          |  |     |   |         |     |      | 569      | .73 | .001 | 395      | 1.05 | .003 | 206      | 1.74 | .008 | 121      | 2.50 | .021 |          |      |      |          |      |      |
| 2D56/2D57          |  |     |   |         |     |      | 705      | .59 | †    | 490      | .85  | .002 | 254      | 1.40 | .006 | 149      | 2.00 | .013 | 79       | 1.91 | .024 | 73       | 2.38 | .033 |
| 11D56/11D57        |  |     |   |         |     |      |          |     |      | 434      | .66  | †    | 244      | 1.17 | .005 | 156      | 1.82 | .012 | 108      | 2.62 | .024 | 100      | 2.85 | .029 |

Note: To convert 1.5 safety factor to 2.0, multiply w, d, k, by .75.  
 : Metric equivalent in ( )

# LADDER CABLE TRAY SYSTEM

## OVERVIEW

**AB-COPE SWAGE LADDER** Is a structure consisting of two side rails, connected by individual rungs and is manufactured in accordance with NEMA Standard VE-1. AB-Cope rungs are fastened to the side members by an exclusive swaging process. This assembly method insures a superior mechanical and electrical connection.

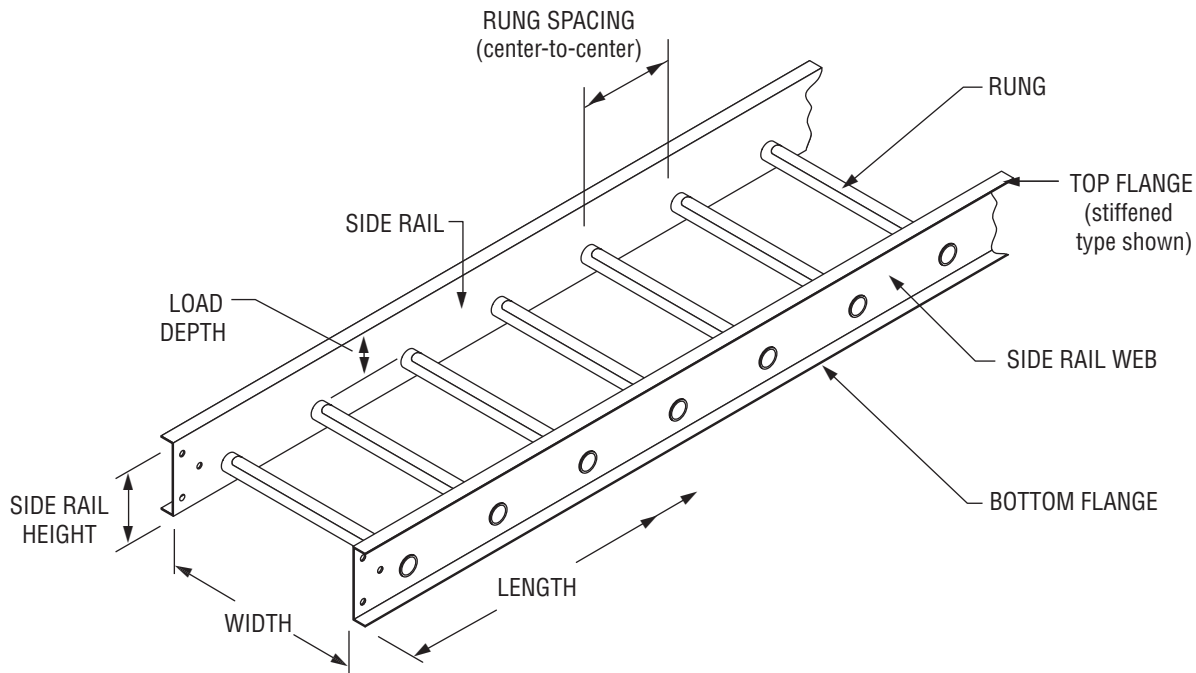

**Side Members** - AB-Cope side members are designed with top and bottom flanges turned outward. This simplifies fastening the cable tray to the supports. Cable tray with outward facing flanges allows complete access within the cable loading area and eliminates the possibility of cable damage from sharp edges within the cable area. The return on the top flange strengthens the side member and allows cable to be smoothly dropped over the side.

**Rung** - AB-Cope ladder rungs are 1.00" diameter tubing flattened on top to provide a cable bearing surface. This construction allows cable to drop out anywhere without contacting a sharp edge.

**Rung Spacing** - The interval at which rungs are swaged to the side member. This is measured from centerline of rung to centerline of rung. AB-Cope manufactures straight lengths with four standard rung spacings; 6", 9", 12", and 18". Rung spacing selected is generally determined by size and type of cable being supported. When in doubt, 9" rung spacing is a generally accepted compromise.

**Length** - The longitudinal dimensions of standard AB-Cope Cable Ladder are 10', 12', 20' or 24'.

**Width** - The transverse dimensions of AB-Cope Cable Ladder are measured inside, (from side member web to side members), and are furnished in seven standard widths: 6", 9", 12", 18", 24", 30", or 36".

**Overall Width** - Overall ladder width is equal to the inside or nominal width plus the width of side member flanges.

**Load Depth** - Measured from top surface of rung to top of side member. This is not to be confused with overall height. AB-Cope manufactures four loading depths: 3", 4", 5", and 6" in accordance with NEMA Standard VE-1. All AB-Cope part numbers refer to the load depth of the tray.

**Overall Height** - AB-Cope overall height is equal to the loading depth plus 1 1/4".

**Fittings** - For changing direction horizontally and vertically, AB-Cope manufactures elbows, tees and crosses in all widths and loading depths. Fittings are available in three standard radii; 12", 24", and 36". AB-Cope maintains a nominal 9" rung spacing through the centerline of all fittings.

### AB-COPE CABLE LADDER FEATURES IMPORTANT INDUSTRY-LEADING FEATURES:

#### 1. Universal Curvilinear Splice Plate System

The splice plates for rigid connections have a slight curve so they can be used on straight sections or fittings. Tightening of the fastener pulls the plate flush with the side rail. The fasteners are snug and the joint is superior structurally and electrically. Even when tightened by hand, there is pressure on the fastener to hold it securely.

**Note:** Heavy Duty, Mid Span Splice Plates available upon request

#### 2. Zero Tangent Fittings

Tangent as referred to on cable tray fittings is the straight at the end of the curve to accommodate a flat splice plate. Zero Tangent Fittings facilitates installation when parallel cable trays must be located at minimum distances from each other, such as motor control centers and switch gear centers. AB-COPE ZERO TANGENT FITTINGS CAN SAVE UP TO 12" PER ROW OF TRAY.

**BONUS:** Inspection for proper installation of splice plate is visual. If the plate is bowed away from the rail, nuts must be tightened.

#### 3. AB-Cope's Swaged Rung Cable Ladder System Process

The heart of the AB-Cope design is the tubular rung and its connection to the side rail by cold swaging... a process where special machinery compresses and locks the tubular rung material around both the inside and outside of the cable tray side rails. This connection is made without the use of heat, which can potentially disturb the molecular structure of the metal and weaken it.

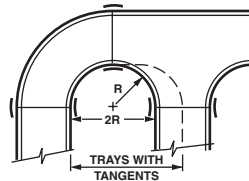

The tubular rung is flattened during the swaging process to ensure a proper cable bearing surface.

**Testing** - The superior strength of the swaged ladder tray system has been verified in independent testing conducted by the Pittsburgh Testing Laboratory. Pullout loads of 2500 lbs. were reached. Other tests show the same type rungs, when welded, had a 35% lower pullout load.

The strength of the swage also maintains the 90° relationship of the rungs to the side rail. The tubular rungs, which are very stiff, transmit the cable loads to the side rails resulting in much less deflection than in a similar system with welded rungs.

**Swage Advantages** - Cold swaging allows for the side rails to be turned outward, simplifying cable installation, and provides 100% access to the cables.

The cold swaging yields the most rigid tray system in the industry. The swaged rung connection resists stresses in all directions; up or down, side to side, or in and out. The swaged ladder also resists the camber and warping effects encountered in a typical welded system.

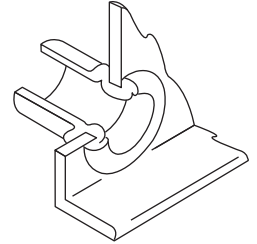

The increased rigidity means that a 24' section of tray can be lifted on one end with little or no twisting or bending of the tray section. This rigid construction makes the trays safer for field personnel to handle and reduces shipping damage.

**Electrical Properties** - Electrically, the 106 tons of pressure in the swaging process virtually eliminates the interstices and a homogenous electrical path results: Resistance

of AB-Cope Aluminum Swaged Tray: 31 microhms

Resistance of AB-Cope Steel Swaged Tray: 37.3 microhms

Resistance of Popular Aluminum Welded Tray: 101 microhms

**Conclusion** - Cold swaging yields a very strong, efficient and aesthetically pleasing system that has stood the test of time and offers installation savings due to its ease of handling.

## PART NUMBERING SYSTEM:

Please pay careful attention to the part numbering structure. Example: Catalog No. 1B48-06SL-12-09 is a 4" load depth aluminum ladder with a 1 3/16" flange, 6 inches wide, straight length 12 feet long, rungs on 9" centers. Please make sure to use the system numbers from pages 26 through 29 when ordering.

### Straight Length

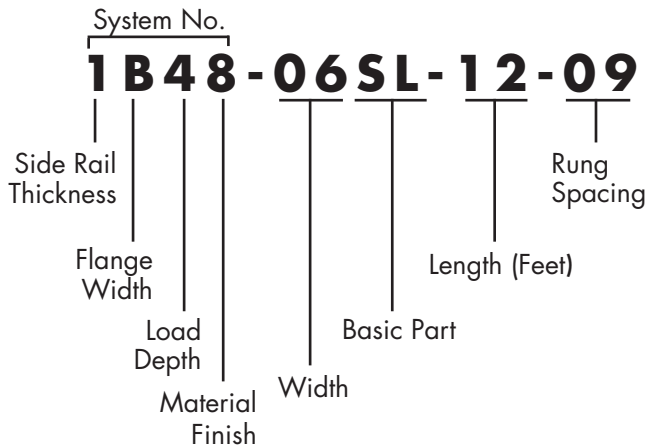

### Fittings

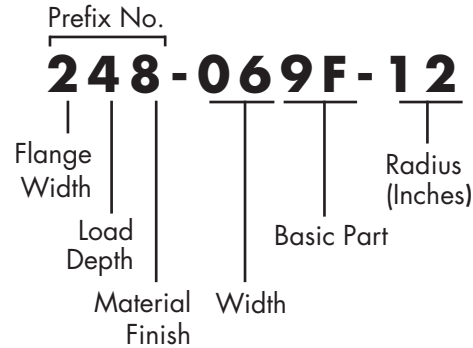

**SYSTEM NUMBER (STRAIGHT SECTION ONLY)** – The first four digits make up the system number which identifies the structural, dimensional and material characteristics of the straight length. It is made up of the side rail digits indicating the side rail thickness and flange width, the load depth (inside, in inches), and material finish (galvanized, aluminum or coated).

**PREFIX NUMBER (FITTINGS ONLY)** – Fittings are ordered using the 3-digit prefix number given in the charts on the fitting pages. Fittings do not have stiffened upper flanges.

**WIDTH** – Identifies the inside width of the tray in inches. Note: Sizes 42" and 48" are not recognized by NEMA

**BASIC PART NUMBER** – Identifies the straight length, fitting or accessory.

**SECONDARY DIMENSION NUMBER** – Identifies the length of a straight section in feet, the radius of a fitting in inches, or the second width of a reducer in inches.

**RUNG SPACING** – Identifies the center-to-center distance between rungs on straight length. Nominal 9" (229mm) rung spacing maintained through center line of all fittings.

| Thickness Steel (Ga.) | Flange Width       | Load Depth | Material Finish |
|-----------------------|--------------------|------------|-----------------|
| 8 - 18 ga.            | 2 - 1 3/16" (21mm) | 3" (76mm)  | 6 - Mill-Galv.  |
| 6 - 16 ga.            | 4 - 1 1/4" (32mm)  | 4" (102mm) | 7 - HDGAF       |
| 4 - 14 ga.            | 5 - 1 1/2" (38mm)  | 5" (127mm) | 8 - Aluminum    |
| 2 - 12 ga.            | 6 - 1 3/4" (45mm)  | 6" (152mm) | T - 304SS       |
| 11 - 11 ga.           | 7 - 2" (51mm)      |            |                 |
| Thickness Alum (in.)  |                    |            |                 |
| 1 - Thinner           | B - 1 3/16" (21mm) |            |                 |
| 3 -                   | D - 1 1/4" (32mm)  |            |                 |
| 5 - ** ↓              | E - 1 1/2" (38mm)  |            |                 |
| 7 -                   | F - 1 3/4" (45mm)  |            |                 |
| 9 - Thicker           | G - 2" (51mm)      |            |                 |

\*\*Alum. extruded side rails are individually engineered to loads and spans.

\*\*\* Contact factory for 42" and 48" width tray (not NEMA Standard)

| Description      |                                |                 |                 |
|------------------|--------------------------------|-----------------|-----------------|
| Width (in.) ***  | Basic Part Number              | Length          | Rung Spacing    |
| -06=6" (152mm)   | SL (Straight Len.)             | - 12' (3.7m)    | 06=6" (152mm)   |
| -09=9" (229mm)   | 9F (90° Horiz. El.)            | - 24' (7.3m)    | 09=9" (229mm)   |
| -12=12" (305mm)  | 6F (60° Horiz. El.)            | - 10' (3m, CSA) | 12=12" (305mm)  |
| -18=18" (457mm)  | 4F (45° Horiz. El.)            | - 20' (6m, CSA) | 18=18" (457mm)  |
| -24=24" (610mm)  | 3F (30° Horiz. El.)            |                 |                 |
| -30=30" (762mm)  | 90 (90° Out. Vert.El.)         |                 |                 |
| -36=36" (914mm)  | 60 (60° Out. Vert. El.)        |                 |                 |
| -42=42" (1067mm) | 40 (45° Out. Vert. El.)        |                 |                 |
| -48=48" (1219mm) | 30 (30° Out. Vert. El.)        |                 |                 |
|                  | 9I (90° In. Vert. El.)         |                 |                 |
|                  | 6I (60° In. Vert. El.)         |                 |                 |
|                  | 4I (45° In. Vert. El.)         |                 |                 |
|                  | 3I (30° In. Vert. El.)         |                 |                 |
|                  | FT (Horiz. Tee)                |                 |                 |
|                  | FC (Horiz. Cross)              |                 |                 |
|                  | TT (Horiz. Tapped Tee)         |                 |                 |
|                  | TC (Horiz. Tapped Cross)       |                 |                 |
|                  | VT (Vert. Tee)                 |                 |                 |
|                  | SR (Vert. Cable Support Elbow) |                 |                 |
|                  | ST (Straight Reducer)          |                 |                 |
|                  | RH (Right Hand Reducer)        |                 |                 |
|                  | LH (Left Hand Reducer)         |                 |                 |
|                  | AF (Adjustable Elbow)          |                 |                 |
|                  | LY (45° Left "Y" Branch)       |                 |                 |
|                  | RY (45° Right "Y" Branch)      |                 |                 |
|                  |                                |                 | Radius (in.)    |
|                  |                                |                 | -12=12" (205mm) |
|                  |                                |                 | -24=24" (610mm) |
|                  |                                |                 | -36=36" (914mm) |

### Straight Length [SL]

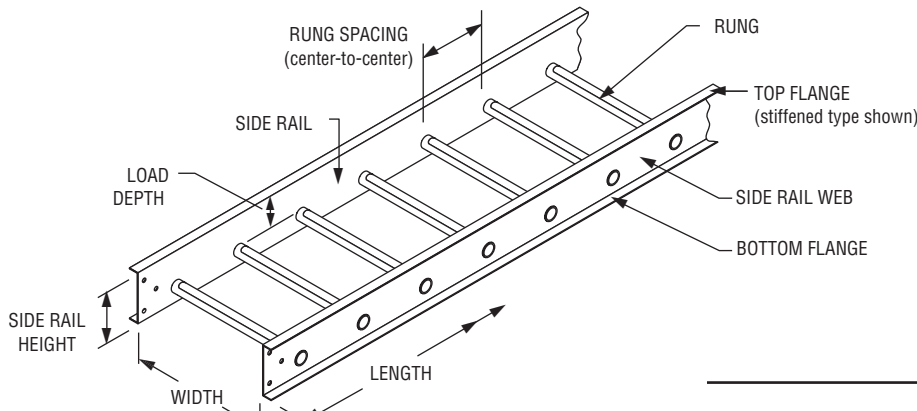

### AB-COPE LADDER

is manufactured in 10' (CSA), 12', 20' (CSA), and 24' lengths; 6", 9", 12", 18", 24", 30", and 36" widths; and, 3", 4", 5", and 6" load depths. Rungs are 1" diameter tubes with a 7/8" flattened cable support surface. 6", 9", 12", and 18" rung spacings are available. Fittings have nominal 9" rung spacing through center line. Dimensions given are inside. For overall widths add two flange widths of the system selected (see Selection Charts). Some systems have stiffened upper (top) flanges to obtain rigidity required (see Selection Charts).

Rungs are assembled to side rails by AB-Cope's exclusive cold swaging process. Outward facing flanges allow full unobstructed access to contents of tray in width and depth.

Materials: Aluminum, Hot Dip Mill-Galvanized (pre galvanized) to ASTM A-653, Hot Dip Galvanized After Fabrication (HDGAF) to ASTM A-123, Stainless Steel (Type 304 and 316). Sufficient connectors are supplied to assemble straight sections and fittings for each order. Connectors for field cuts to be ordered separately (see Connectors).

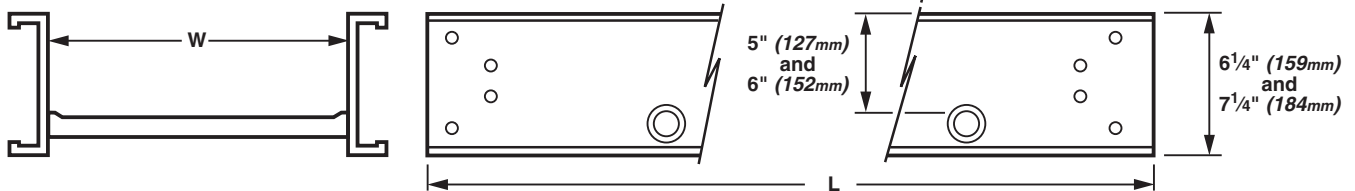

**MATERIAL & FINISH SPECIFICATIONS (Ladder Cable Tray)**

|                            | Pre-Galvanized Steel   | Hot-Dip Galvanized after Fabrication ASTM A-123          | Aluminum  | Type 304 Stainless Steel                    |
|----------------------------|--|--|---|---|
| <b>Siderails</b>           | ASTM A-653-G90 CS (18 & 16 Gage)<br>ASTM A-653-G90 CS (14 & 12 Gage) | ASTM A-1008 (18 & 16 Gage)<br>ASTM A-1011 (14 & 12 Gage) | AA-6063-T6 Extruded   | ASTM A-240; Type 304                        |
| <b>Rungs</b>               | ASTM A-653-G90 CS  | ASTM A-1008  | AA-6063-T6 Extruded*<br>AA-6063-T832 Extruded*<br>AA-6063-T52 Extruded* | ASTM A-269; Type 304                        |
| <b>Splice Plate Finish</b> | ASTM A-1011<br>ASTM A-591 Class C                                    | ASTM A-1011<br>ASTM A-123 Grade 65                       | AA-5052-H34   | ASTM A-240; Type 304<br>2B Finish (Typical) |
| <b>Connector Bolts</b>     | SAE J429 Grade 1<br>(ASTM A-307 Grade A)                             | SAE J429 Grade 1<br>(ASTM A-307 Grade A)                 | SAE J429 Grade 1<br>(ASTM A-307 Grade A)                                | AISI Type 304 Stainless Steel               |
| <b>Bolt Plating</b>        | ASTM B-633.0002" Zinc  | ASTM B-633.0002" Zinc                                    | ASTM B-633.0002" Zinc   |   |
| <b>Covers</b>              | ASTM A-653-G90 CQ  | ASTM A-653-G90 CQ  | AA-3003 H14 or 3150 H14   | ASTM A-240; Type 304                        |

\*Special High Strength 32 ksi Minimum Yield

| Catalog Number  |          |           |        |              |                 |                 |
|-----------------|----------|-----------|--------|--------------|-----------------|-----------------|
| System          | Width    | Basic No. | Length | Rung Spacing |                 |                 |
| See Pages 25-29 | -06=6"   | (152mm)   | SL     | NEMA         | -06=6" (152mm)  |                 |
|                 | -09=9"   | (229mm)   |        |              | 12' (3.7m)*     | -09=9" (229mm)  |
|                 | -12=12"  | (305mm)   |        |              | 24' (7.3m)*     | -12=12" (305mm) |
|                 | -18=18"  | (457mm)   |        |              | 10' (3m)*       |                 |
|                 | -24=24"  | (610mm)   |        | CSA          | 20' (6m)*       |                 |
|                 | -30=30"  | (762mm)   |        |              | -18=18" (457mm) |                 |
|                 | -36=36"  | (914mm)   |        |              |                 |                 |
|                 | -42=42"  | (1067mm)  |        |              |                 |                 |
| -48=48"         | (1219mm) |           |        |              |                 |                 |

\*10' & 12' all NEMA Classes, 20' & 24' NEMA Classes 16A, 16B, 16C, 20A, 20B, 20C.

\*\* not NEMA standard width

EXAMPLE: Catalog No. 1B48-06SL-12-09 is a 4-inch load depth aluminum ladder with a 13/16" flange, 6 inches wide, straight length 12 feet long, rungs on 9" centers.

|             | Conversion Table |     |     |     |     |     | CSA |      |      |     |     |
|-------------|------------------|-----|-----|-----|-----|-----|-----|------|------|-----|-----|
| English     | 6"               | 9"  | 12" | 18" | 24" | 30" | 36" | 12'  | 24'  | 10' | 20' |
| Metric (mm) | 152              | 229 | 305 | 457 | 610 | 762 | 914 | 3.7m | 7.3m | 3m  | 6m  |

# LADDER CABLE TRAY SYSTEM



## CSA ORDERING INFORMATION

### AB-Cope CSA Standards C22-2 Cable Trof Ladder Type

#### HOW TO ORDER:

Explanation of ABCope's Canadian Standards cable tray catalog numbers is described below. Use the system numbers given in selection charts for straight sections, or the fitting prefix numbers given in fitting tables. Be sure to follow system number or the fitting prefix with the item "description" number. The list below gives the CSA certified item carrying the CSA label.



#### Straight Length

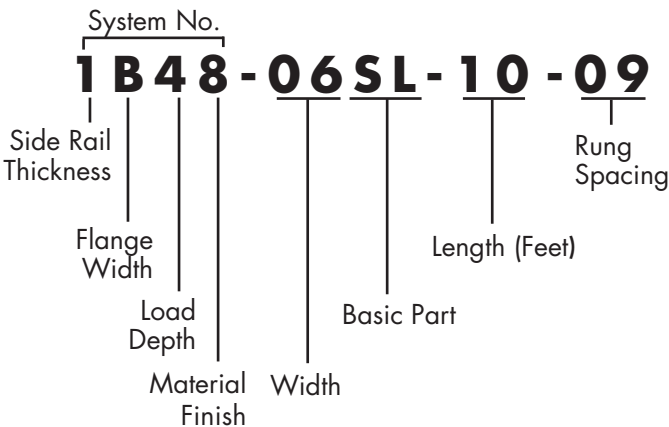

#### Fittings

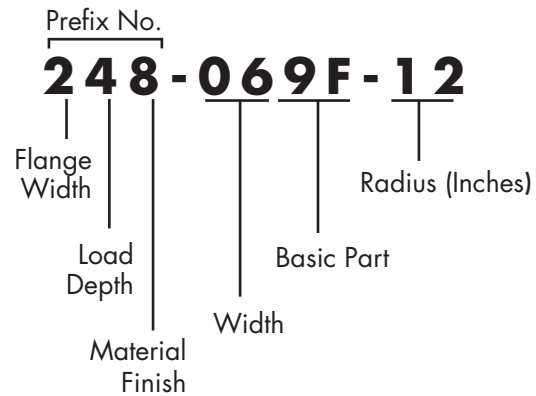

#### SYSTEM NUMBER (STRAIGHT SECTION ONLY) –

The first four digits make up the system number which identifies the structural, dimensional, and material characteristics of the straight length. It is made up of the side rail digits indicating the side rail thickness and flange width, the load depth (inside, in inches), and material finish (galvanized, aluminum or coated).

**PREFIX NUMBER (FITTINGS ONLY) –** Fittings are ordered using the 3-digit prefix number given in the charts on the fitting pages. Fittings do not have stiffened upper flanges.

**WIDTH –** Identifies the inside width of the tray in inches. Note: Sizes 42" and 48" are not recognized by NEMA

**BASIC PART NUMBER –** Identifies the straight length, fitting, or accessory.

| Thickness Steel (Ga.) | Flange Width                                 | Load Depth | Material Finish           |
|-----------------------|--|------------|---------------------------|
| 8 - 18 ga.            | 2 - 1 <sup>3</sup> / <sub>16</sub> " (21mm)  | 3" (76mm)  | 7 - HDGAF                 |
| 6 - 16 ga.            | 4 - 1 <sup>1</sup> / <sub>4</sub> " (32mm)   | 4" (102mm) | CSA Class 1               |
| 4 - 14 ga.            | 6 - 1 <sup>3</sup> / <sub>4</sub> " (45mm)   | 5" (127mm) | 8 - Aluminum Plain Finish |
|                       | *B - 1 <sup>3</sup> / <sub>16</sub> " (21mm) | 6" (152mm) |                           |
|                       | *D - 1 <sup>1</sup> / <sub>4</sub> " (32mm)  |            |                           |
| Thickness Alum (in.)  |  |            |                           |
| 1 - Thinner           |  |            |                           |
| 3 - ↓                 |  |            |                           |
| 5 - ** ↓              |  |            |                           |
| 7 - Thicker           |  |            |                           |

\*Stiffened Upper Flange

\*\*Alum. extruded side rails are individually engineered to loads and spans.

**SECONDARY DIMENSION NUMBER –** Identifies the length of a straight section in feet, the radius of a fitting in inches, or the second width of a reducer in inches.

**RUNG SPACING –** Identifies the center-to-center distance between rungs on straight length. Nominal 9" (229mm) rung spacing maintained through center line of all fittings.

| Description      |                                |             |                |
|------------------|--------------------------------|-------------|----------------|
| Width (in.)      | Basic Part Number              | Length      | Rung Spacing   |
| -06=6" (152mm)   | SL (Straight Len.)             | 10-10' (3m) | 06=6" (152mm)  |
| -09=9" (229mm)   | 9F (90° Horiz. El.)            | 20-20' (6m) | 09=9" (229mm)  |
| -12=12" (305mm)  | 6F (60° Horiz. El.)            |             | 12=12" (305mm) |
| -18=18" (457mm)  | 4F (45° Horiz. El.)            |             |                |
| -24=24" (610mm)  | 3F (30° Horiz. El.)            |             |                |
| -30=30" (762mm)  | 90 (90° Out. Vert. El.)        |             |                |
| -36=36" (914mm)  | 60 (60° Out. Vert. El.)        |             |                |
| -42=42" (1067mm) | 40 (45° Out. Vert. El.)        |             |                |
| -48=48" (1219mm) | 30 (30° Out. Vert. El.)        |             |                |
|                  | 9I (90° In. Vert. El.)         |             |                |
|                  | 6I (60° In. Vert. El.)         |             |                |
|                  | 4I (45° In. Vert. El.)         |             |                |
|                  | 3I (30° In. Vert. El.)         |             |                |
|                  | FT (Horiz. Tee)                |             |                |
|                  | FC (Horiz. Cross)              |             |                |
|                  | VT (Vert. Tee)                 |             |                |
|                  | SR (Vert. Cable Support Elbow) |             |                |
|                  | ST (Straight Reducer)          |             |                |
|                  | RH (Right Hand Reducer)        |             |                |
|                  | LH (Left Hand Reducer)         |             |                |
|                  | AF (Adjustable Elbow)          |             |                |
|                  | RY & LY (45° "Y" Branch)       |             |                |



**AB-COPE Systems That Meet Performance Class CSA Std.C22.2**

| CSA COMPLIANCE Load Class                           | Cope System | Load Depth | Side Rail      | Flange Width   | Max. Load Kg/m (lb/ft) | Maximum Support Span | Deflection at Max Support Span | Meets CSA Elec. Tests |
|---|-------------|------------|----------------|----------------|------------------------|----------------------|--------------------------------|-----------------------|
| <b>ALUMINUM LADDER TRAY - Safety Factor: 1.5</b>    |             |            |                |                |                        |                      |                                |                       |
| C   | <b>1B38</b> | 3" (76mm)  | 4 1/4" (108mm) | 1 3/16" (21mm) | 97 (65)                | 3m                   | 25.1mm                         | Yes                   |
| D   | <b>3D38</b> | 3" (76mm)  | 4 1/4" (108mm) | 1 1/4" (32mm)  | 67 (45)                | 6m (1)               | 108.5mm                        | Yes                   |
| 16C   | <b>5D38</b> | 3" (76mm)  | 4 1/4" (108mm) | 1 1/4" (32mm)  | 149 (100)              | 4.9m                 | 69.3mm                         | Yes                   |
| C   | <b>1B48</b> | 4" (102mm) | 5 1/4" (133mm) | 1 3/16" (21mm) | 97 (65)                | 3m                   | 22.1mm                         | Yes                   |
| 20A   | <b>7448</b> | 4" (102mm) | 5 1/4" (133mm) | 1 1/4" (32mm)  | 74 (50)                | 6m (1)               | 73.4mm                         | Yes                   |
| 20B   | <b>3D48</b> | 4" (102mm) | 5 1/4" (133mm) | 1 1/4" (32mm)  | 112 (75)               | 6m (1)               | 79.8mm                         | Yes                   |
| 20A   | <b>1D58</b> | 5" (127mm) | 6 1/4" (159mm) | 1 1/4" (32mm)  | 74 (50)                | 6m (1)               | 63.8mm                         | Yes                   |
| 20B   | <b>5D58</b> | 5" (127mm) | 6 1/4" (159mm) | 1 1/4" (32mm)  | 112 (75)               | 6m (1)               | 54.9mm                         | Yes                   |
| E   | <b>3658</b> | 5" (127mm) | 6 1/4" (159mm) | 1 3/4" (45mm)  | 112 (75)               | 6m (1)               | 64.8mm                         | Yes                   |
| 20C   | <b>7D58</b> | 5" (127mm) | 6 1/4" (159mm) | 1 1/4" (32mm)  | 149 (100)              | 6m (1)               | 76.7mm                         | Yes                   |
| 20C   | <b>5D68</b> | 6" (152mm) | 7 1/4" (184mm) | 1 1/4" (32mm)  | 149 (100)              | 6m (1)               | 54.9mm                         | Yes                   |
| <b>Mil Gal STEEL LADDER TRAY Safety Factor: 1.5</b> |             |            |                |                |                        |                      |                                |                       |
| C   | <b>8B36</b> | 3" (76mm)  | 4 1/4" (108mm) | 1 3/16" (21mm) | 97 (65)                | 3m                   | 17.8mm                         | Yes                   |
| 20A   | <b>6456</b> | 5" (127mm) | 6 1/4" (159mm) | 1 1/4" (32mm)  | 74 (50)                | 6m (1)               | 40.4mm                         | Yes                   |
| E   | <b>6D56</b> | 5" (127mm) | 6 1/4" (159mm) | 1 1/4" (32mm)  | 112 (75)               | 6m (1)               | 46.2mm                         | Yes                   |
| 20C   | <b>4D56</b> | 5" (127mm) | 6 1/4" (159mm) | 1 1/4" (32mm)  | 149 (100)              | 6m (1)               | 48.5mm                         | Yes                   |
| 12B   | <b>8B66</b> | 6" (152mm) | 7 1/4" (184mm) | 1 3/16" (21mm) | 112 (75)               | 3.7m                 | 24.9mm                         | Yes                   |
| 20A   | <b>6466</b> | 6" (152mm) | 7 1/4" (184mm) | 1 1/4" (32mm)  | 74 (50)                | 6m (1)               | 23.1mm                         | Yes                   |
| 20B   | <b>6D66</b> | 6" (152mm) | 7 1/4" (184mm) | 1 1/4" (32mm)  | 112 (75)               | 6m (1)               | 33.8mm                         | Yes                   |
| <b>HDGAF STEEL LADDER TRAY Safety Factor: 1.5</b>   |             |            |                |                |                        |                      |                                |                       |
| C   | <b>8B37</b> | 3" (76mm)  | 4 1/4" (108mm) | 1 3/16" (21mm) | 97 (65)                | 3m                   | 17.8mm                         | Yes                   |
| 20A   | <b>6457</b> | 5" (127mm) | 6 1/4" (159mm) | 1 1/4" (32mm)  | 74 (50)                | 6m (1)               | 40.4mm                         | Yes                   |
| E   | <b>6D57</b> | 5" (127mm) | 6 1/4" (159mm) | 1 1/4" (32mm)  | 112 (75)               | 6m (1)               | 46.2mm                         | Yes                   |
| 12B   | <b>8B67</b> | 6" (152mm) | 7 1/4" (184mm) | 1 3/16" (21mm) | 112 (75)               | 3.7m                 | 24.9mm                         | Yes                   |
| 20A   | <b>6467</b> | 6" (152mm) | 7 1/4" (184mm) | 1 1/4" (32mm)  | 74 (50)                | 6m (1)               | 23.1mm                         | Yes                   |
| 20B   | <b>6D67</b> | 6" (152mm) | 7 1/4" (184mm) | 1 1/4" (32mm)  | 112 (75)               | 6m (1)               | 33.8mm                         | Yes                   |

**Notes:** (1) Also recommended for 3 meter support spans

**Note:** [Shaded] indicates most common systems. Consult factory for lead times on other systems.

## CSA LOADS

Identify the desired load designation needed for your project from the chart below. Both CSA Class and NEMA designations are listed by load capability and span. Then select the CSA complying AB-Cope System from the table above.

Where CSA C22.2 is not mandatory, you may want to consider other AB-Cope systems offered on the selection charts (page 27 thru 30).

**Historical Load/Span Class Designation**

| Load, kg/m (lb/ft) | Span, m (ft) |          |          |          |          |
|--------------------|--------------|----------|----------|----------|----------|
|                    | 2.4 (8)      | 3.0 (10) | 3.7 (12) | 4.9 (16) | 6.0 (20) |
| 37 (25)            | -            | A        | -        | -        | -        |
| 67 (45)            | -            | -        | -        | -        | D        |
| 74 (50)            | 8A           | -        | 12A      | 16A      | 20A      |
| 97 (65)            | -            | C        | -        | -        | -        |
| 112 (75)           | 8B           | -        | 12B      | 16B      | E or 20B |
| 149 (100)          | 8C           | -        | 12C      | 16C      | 20C      |
| 179 (120)          | -            | D        | -        | -        | -        |
| 299 (200)          | -            | E        | -        | -        | -        |

**Note:** 8A/B/C, 12A/B/C, 16A/B/C, and 20A/B/C have been NEMA designations.  
A, B, C, D and E have been CSA designations

## RECEIVING, INSTALLING, AND MAINTENANCE

The proper care and handling of cable trays by the receiver and installers is very important to insure a safe installation that will meet the intended service life. AB-Cope has an installation guide available to assist the installers and those who will maintain the installed system.

## DIMENSIONS AND STRUCTURAL PROPERTIES: AB-COPE CSA SYSTEMS

The performance of the AB-Cope cable trays systems complying CSA is given above. Structural properties of straight sections, though not required to be listed, are given in the AB-Cope NEMA selection charts, in English units. Dimensions of straight sections and certified fittings are furnished in English and metric units for use in layout and/or entry into computerized systems.

**Note:** For other CSA compliance systems please contact the factory.

## 90° Horizontal Elbow [9F]

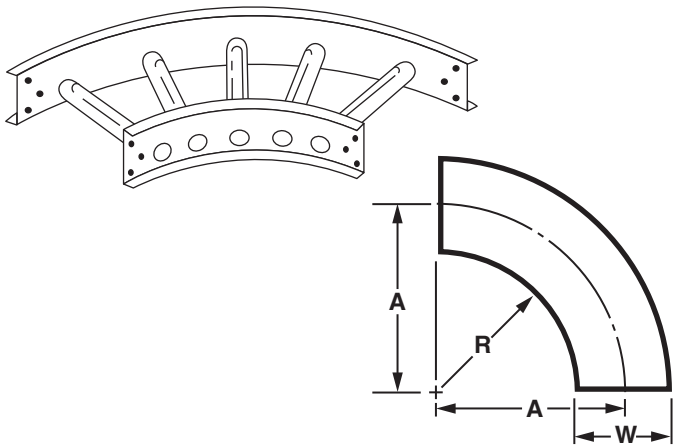

CSA compliance for CSA Systems

| Radius - R     | Width - W    | "A" Dimension |  |
|----------------|--------------|---------------|--|
| 12"<br>(305mm) | 6" (152mm)   | 15" (381mm)   |  |
|                | 9" (229mm)   | 16½" (419mm)  |  |
|                | 12" (305mm)  | 18" (457mm)   |  |
|                | 18" (457mm)  | 21" (533mm)   |  |
|                | 24" (610mm)  | 24" (610mm)   |  |
|                | 30" (762mm)  | 27" (686mm)   |  |
|                | 36" (914mm)  | 30" (762mm)   |  |
|                | 42" (1067mm) | 33" (838mm)   |  |
| 24"<br>(610mm) | 48" (1219mm) | 36" (914mm)   |  |
|                | 6" (152mm)   | 27" (686mm)   |  |
|                | 9" (229mm)   | 28½" (724mm)  |  |
|                | 12" (305mm)  | 30" (762mm)   |  |
|                | 18" (457mm)  | 33" (838mm)   |  |
|                | 24" (610mm)  | 36" (914mm)   |  |
|                | 30" (762mm)  | 39" (991mm)   |  |
|                | 36" (914mm)  | 42" (1067mm)  |  |
| 36"<br>(914mm) | 42" (1067mm) | 45" (1143mm)  |  |
|                | 48" (1219mm) | 48" (1219mm)  |  |
|                | 6" (152mm)   | 39" (991mm)   |  |
|                | 9" (229mm)   | 40½" (1029mm) |  |
|                | 12" (305mm)  | 42" (1067mm)  |  |
|                | 18" (457mm)  | 45" (1143mm)  |  |
|                | 24" (610mm)  | 48" (1219mm)  |  |
|                | 30" (762mm)  | 51" (1295mm)  |  |
| 48" (1219mm)   | 36" (914mm)  | 54" (1372mm)  |  |
|                | 42" (1067mm) | 57" (1448mm)  |  |
|                | 48" (1219mm) | 60" (1524mm)  |  |

EXAMPLE: 238-129F-12

## 60° Horizontal Elbow [6F]

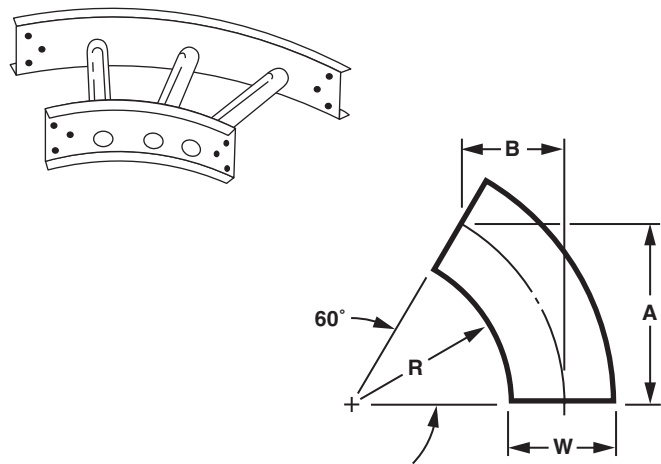

CSA compliance for CSA Systems

| Radius - R     | Width - W    | "A" Dimension   |  | "B" Dimension |  |
|----------------|--------------|-----------------|--|---------------|--|
| 12"<br>(305mm) | 6" (152mm)   | 13" (330mm)     |  | 7½" (191mm)   |  |
|                | 9" (229mm)   | 14¼" (362mm)    |  | 8¼" (210mm)   |  |
|                | 12" (305mm)  | 15⅝" (397mm)    |  | 9" (229mm)    |  |
|                | 18" (457mm)  | 18¼" (464mm)    |  | 10½" (267mm)  |  |
|                | 24" (610mm)  | 20¾" (527mm)    |  | 12" (305mm)   |  |
|                | 30" (762mm)  | 23⅜" (594mm)    |  | 13½" (343mm)  |  |
|                | 36" (914mm)  | 26" (660mm)     |  | 15" (381mm)   |  |
|                | 42" (1067mm) | 28⅞" (725mm)    |  | 16½" (419mm)  |  |
| 24"<br>(610mm) | 48" (1219mm) | 31⅞" (791mm)    |  | 18" (457mm)   |  |
|                | 6" (152mm)   | 23⅞" (594mm)    |  | 13½" (343mm)  |  |
|                | 9" (229mm)   | 24¾" (629mm)    |  | 14¼" (362mm)  |  |
|                | 12" (305mm)  | 26" (660mm)     |  | 15" (381mm)   |  |
|                | 18" (457mm)  | 28⅝" (727mm)    |  | 16½" (416mm)  |  |
|                | 24" (610mm)  | 31¼" (794mm)    |  | 18" (457mm)   |  |
|                | 30" (762mm)  | 33¾" (857mm)    |  | 19½" (495mm)  |  |
|                | 36" (914mm)  | 36⅜" (924mm)    |  | 21" (533mm)   |  |
| 36"<br>(914mm) | 42" (1067mm) | 38⅟¹⁶" (989mm)  |  | 22½" (572mm)  |  |
|                | 48" (1219mm) | 41⅞" (1056mm)   |  | 24" (610mm)   |  |
|                | 6" (152mm)   | 33¾" (857mm)    |  | 19½" (495mm)  |  |
|                | 9" (229mm)   | 35⅞" (892mm)    |  | 20¼" (514mm)  |  |
|                | 12" (305mm)  | 36⅜" (924mm)    |  | 21" (533mm)   |  |
|                | 18" (457mm)  | 39" (991mm)     |  | 22½" (572mm)  |  |
|                | 24" (610mm)  | 41⅝" (1057mm)   |  | 24" (610mm)   |  |
|                | 30" (762mm)  | 44⅞" (1121mm)   |  | 25½" (648mm)  |  |
| 48" (1219mm)   | 36" (914mm)  | 46¾" (1187mm)   |  | 27" (686mm)   |  |
|                | 42" (1067mm) | 49⅟¹⁶" (1253mm) |  | 28½" (724mm)  |  |
|                | 48" (1219mm) | 51⅟¹⁶" (1319mm) |  | 30" (762mm)   |  |

EXAMPLE: 238-126F-12

**Note:** Use Adjustable Connectors for odd angles. Nominal 9" rung spacing maintained through centerline of all fittings.

### Ordering Information:

See Page 62  
for Electrical  
Grounding Chart

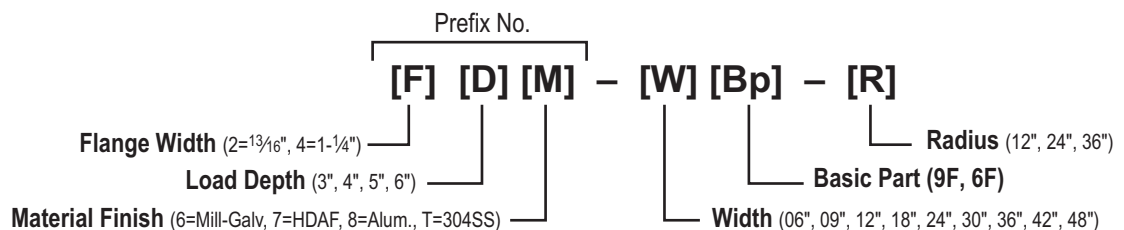

## 45° Horizontal Elbow [4F]

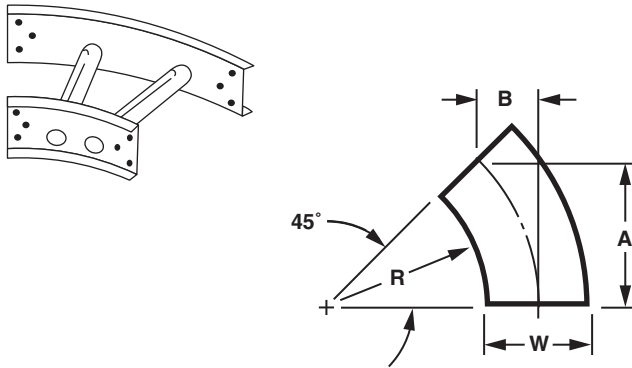

CSA compliance for CSA Systems

| Radius - R     | Width - W    | "A" Dimension                              | "B" Dimension                             |
|----------------|--------------|--|---|
| 12"<br>(305mm) | 6" (152mm)   | 10 <sup>5</sup> / <sub>8</sub> " (270mm)   | 4 <sup>3</sup> / <sub>8</sub> " (111mm)   |
|                | 9" (229mm)   | 11 <sup>5</sup> / <sub>8</sub> " (295mm)   | 4 <sup>7</sup> / <sub>8</sub> " (124mm)   |
|                | 12" (305mm)  | 12 <sup>3</sup> / <sub>4</sub> " (324mm)   | 5 <sup>1</sup> / <sub>4</sub> " (133mm)   |
|                | 18" (457mm)  | 14 <sup>7</sup> / <sub>8</sub> " (378mm)   | 6 <sup>1</sup> / <sub>8</sub> " (156mm)   |
|                | 24" (610mm)  | 17" (432mm)                                | 7" (178mm)                                |
|                | 30" (762mm)  | 19 <sup>7</sup> / <sub>8</sub> " (486mm)   | 7 <sup>7</sup> / <sub>8</sub> " (200mm)   |
|                | 36" (914mm)  | 21 <sup>1</sup> / <sub>4</sub> " (540mm)   | 8 <sup>3</sup> / <sub>4</sub> " (222mm)   |
|                | 42" (1067mm) | 23 <sup>5</sup> / <sub>16</sub> " (592mm)  | 9 <sup>5</sup> / <sub>8</sub> " (244mm)   |
| 24"<br>(610mm) | 48" (1219mm) | 25 <sup>7</sup> / <sub>16</sub> " (646mm)  | 10 <sup>1</sup> / <sub>2</sub> " (267mm)  |
|                | 6" (152mm)   | 19 <sup>1</sup> / <sub>8</sub> " (486mm)   | 7 <sup>7</sup> / <sub>8</sub> " (200mm)   |
|                | 9" (229mm)   | 20 <sup>1</sup> / <sub>8</sub> " (511mm)   | 8 <sup>3</sup> / <sub>8</sub> " (213mm)   |
|                | 12" (305mm)  | 21 <sup>1</sup> / <sub>4</sub> " (540mm)   | 8 <sup>3</sup> / <sub>4</sub> " (222mm)   |
|                | 18" (457mm)  | 23 <sup>3</sup> / <sub>8</sub> " (594mm)   | 9 <sup>5</sup> / <sub>8</sub> " (244mm)   |
|                | 24" (610mm)  | 25 <sup>1</sup> / <sub>2</sub> " (648mm)   | 10 <sup>1</sup> / <sub>2</sub> " (267mm)  |
|                | 30" (762mm)  | 27 <sup>5</sup> / <sub>8</sub> " (702mm)   | 11 <sup>1</sup> / <sub>2</sub> " (292mm)  |
|                | 36" (914mm)  | 29 <sup>3</sup> / <sub>4</sub> " (756mm)   | 12 <sup>3</sup> / <sub>8</sub> " (314mm)  |
| 36"<br>(914mm) | 42" (1067mm) | 31 <sup>13</sup> / <sub>16</sub> " (808mm) | 13 <sup>1</sup> / <sub>8</sub> " (333mm)  |
|                | 48" (1219mm) | 33 <sup>5</sup> / <sub>16</sub> " (862mm)  | 14" (356mm)                               |
|                | 6" (152mm)   | 27 <sup>5</sup> / <sub>8</sub> " (702mm)   | 11 <sup>1</sup> / <sub>2</sub> " (292mm)  |
|                | 9" (229mm)   | 28 <sup>5</sup> / <sub>8</sub> " (727mm)   | 11 <sup>7</sup> / <sub>8</sub> " (302mm)  |
|                | 12" (305mm)  | 29 <sup>3</sup> / <sub>4</sub> " (756mm)   | 12 <sup>3</sup> / <sub>8</sub> " (314mm)  |
|                | 18" (457mm)  | 31 <sup>7</sup> / <sub>8</sub> " (810mm)   | 13 <sup>1</sup> / <sub>4</sub> " (337mm)  |
|                | 24" (610mm)  | 34" (864mm)                                | 14 <sup>1</sup> / <sub>8</sub> " (359mm)  |
|                | 30" (762mm)  | 36 <sup>1</sup> / <sub>8</sub> " (918mm)   | 15" (381mm)                               |
| 36"<br>(914mm) | 36" (914mm)  | 38 <sup>1</sup> / <sub>4</sub> " (972mm)   | 15 <sup>7</sup> / <sub>8</sub> " (403mm)  |
|                | 42" (1067mm) | 40 <sup>1</sup> / <sub>4</sub> " (1022mm)  | 16 <sup>1</sup> / <sub>16</sub> " (424mm) |
|                | 48" (1219mm) | 42 <sup>3</sup> / <sub>8</sub> " (1076mm)  | 17 <sup>9</sup> / <sub>16</sub> " (446mm) |
|                | 6" (152mm)   | 19 <sup>1</sup> / <sub>2</sub> " (495mm)   | 5 <sup>1</sup> / <sub>4</sub> " (133mm)   |
|                | 9" (229mm)   | 20 <sup>1</sup> / <sub>4</sub> " (514mm)   | 5 <sup>1</sup> / <sub>2</sub> " (140mm)   |
|                | 12" (305mm)  | 21" (533mm)                                | 5 <sup>5</sup> / <sub>8</sub> " (143mm)   |
|                | 18" (457mm)  | 22 <sup>1</sup> / <sub>2</sub> " (572mm)   | 6" (152mm)                                |
|                | 24" (610mm)  | 24" (610mm)                                | 6 <sup>1</sup> / <sub>2</sub> " (165mm)   |
| 36"<br>(914mm) | 30" (762mm)  | 25 <sup>1</sup> / <sub>2</sub> " (648mm)   | 6 <sup>7</sup> / <sub>8</sub> " (175mm)   |
|                | 36" (914mm)  | 27" (686mm)                                | 7 <sup>1</sup> / <sub>4</sub> " (184mm)   |
|                | 42" (1067mm) | 28 <sup>1</sup> / <sub>2</sub> " (724mm)   | 7 <sup>5</sup> / <sub>8</sub> " (194mm)   |
|                | 48" (1219mm) | 30" (762mm)                                | 8" (203mm)                                |

EXAMPLE: 238-124F-12

## 30° Horizontal Elbow [3F]

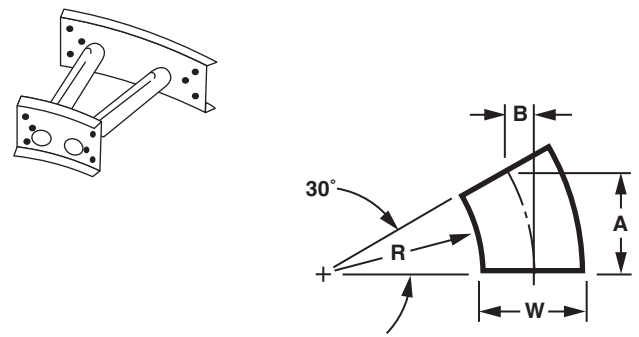

CSA compliance for CSA Systems

| Radius - R     | Width - W    | "A" Dimension                            | "B" Dimension                             |
|----------------|--------------|--|---|
| 12"<br>(305mm) | 6" (152mm)   | 7 <sup>1</sup> / <sub>2</sub> " (191mm)  | 2" (51mm)                                 |
|                | 9" (229mm)   | 8 <sup>1</sup> / <sub>4</sub> " (210mm)  | 2 <sup>1</sup> / <sub>4</sub> " (57mm)    |
|                | 12" (305mm)  | 9" (229mm)                               | 2 <sup>3</sup> / <sub>8</sub> " (60mm)    |
|                | 18" (457mm)  | 10 <sup>1</sup> / <sub>2</sub> " (267mm) | 2 <sup>7</sup> / <sub>8</sub> " (73mm)    |
|                | 24" (610mm)  | 12" (305mm)                              | 3 <sup>1</sup> / <sub>4</sub> " (83mm)    |
|                | 30" (762mm)  | 13 <sup>1</sup> / <sub>2</sub> " (343mm) | 3 <sup>5</sup> / <sub>8</sub> " (92mm)    |
|                | 36" (914mm)  | 15" (381mm)                              | 4" (102mm)                                |
|                | 42" (1067mm) | 16 <sup>1</sup> / <sub>2</sub> " (419mm) | 4 <sup>3</sup> / <sub>8</sub> " (111mm)   |
| 24"<br>(610mm) | 48" (1219mm) | 18" (457mm)                              | 4 <sup>13</sup> / <sub>16</sub> " (122mm) |
|                | 6" (152mm)   | 13 <sup>1</sup> / <sub>2</sub> " (343mm) | 3 <sup>5</sup> / <sub>8</sub> " (92mm)    |
|                | 9" (229mm)   | 14 <sup>1</sup> / <sub>4</sub> " (362mm) | 3 <sup>7</sup> / <sub>8</sub> " (98mm)    |
|                | 12" (305mm)  | 15" (381mm)                              | 4" (102mm)                                |
|                | 18" (457mm)  | 16 <sup>1</sup> / <sub>2</sub> " (419mm) | 4 <sup>3</sup> / <sub>8</sub> " (111mm)   |
|                | 24" (610mm)  | 18" (457mm)                              | 4 <sup>7</sup> / <sub>8</sub> " (124mm)   |
|                | 30" (762mm)  | 19 <sup>1</sup> / <sub>2</sub> " (495mm) | 5 <sup>1</sup> / <sub>4</sub> " (133mm)   |
|                | 36" (914mm)  | 21" (533mm)                              | 5 <sup>5</sup> / <sub>8</sub> " (143mm)   |
| 36"<br>(914mm) | 42" (1067mm) | 22 <sup>1</sup> / <sub>2</sub> " (572mm) | 6" (152mm)                                |
|                | 48" (1219mm) | 24" (610mm)                              | 6 <sup>3</sup> / <sub>8</sub> " (162mm)   |
|                | 6" (152mm)   | 19 <sup>1</sup> / <sub>2</sub> " (495mm) | 5 <sup>1</sup> / <sub>4</sub> " (133mm)   |
|                | 9" (229mm)   | 20 <sup>1</sup> / <sub>4</sub> " (514mm) | 5 <sup>1</sup> / <sub>2</sub> " (140mm)   |
|                | 12" (305mm)  | 21" (533mm)                              | 5 <sup>5</sup> / <sub>8</sub> " (143mm)   |
|                | 18" (457mm)  | 22 <sup>1</sup> / <sub>2</sub> " (572mm) | 6" (152mm)                                |
|                | 24" (610mm)  | 24" (610mm)                              | 6 <sup>1</sup> / <sub>2</sub> " (165mm)   |
|                | 30" (762mm)  | 25 <sup>1</sup> / <sub>2</sub> " (648mm) | 6 <sup>7</sup> / <sub>8</sub> " (175mm)   |
| 36"<br>(914mm) | 36" (914mm)  | 27" (686mm)                              | 7 <sup>1</sup> / <sub>4</sub> " (184mm)   |
|                | 42" (1067mm) | 28 <sup>1</sup> / <sub>2</sub> " (724mm) | 7 <sup>5</sup> / <sub>8</sub> " (194mm)   |
|                | 48" (1219mm) | 30" (762mm)                              | 8" (203mm)                                |

EXAMPLE: 238-123F-12

**Note:** Use Adjustable Connectors for odd angles. Nominal 9" rung spacing maintained through centerline of all fittings.

### Ordering Information:

Prefix No.

[F] [D] [M] - [W] [Bp] - [R]

Flange Width (2=1<sup>3</sup>/<sub>16</sub>", 4=1-1<sup>4</sup>/<sub>4</sub>")

Load Depth (3", 4", 5", 6")

Material Finish (6=Mill-Galv, 7=HDAF, 8=Alum., T=304SS)

Radius (12", 24", 36")

Basic Part (4F, 3F)

Width (06", 09", 12", 18", 24", 30", 36", 42", 48")

See Page 62  
for Electrical  
Grounding Chart

## Horizontal Tee [FT]

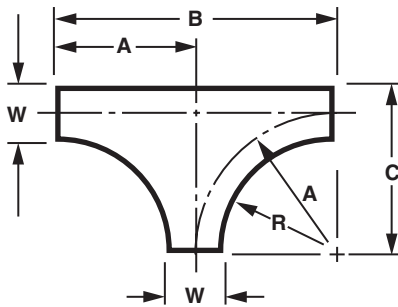
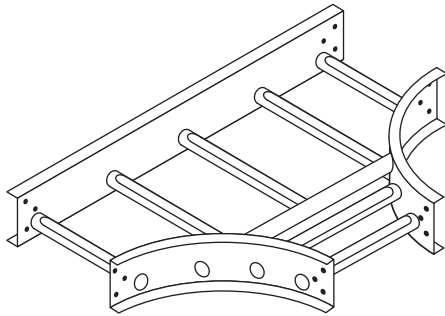

CSA Compliance for CSA Systems

| Radius - R            | Width - W    | "A" Dimension | "B" Dimension | "C" Dimension |
|-----------------------|--------------|---------------|---------------|---------------|
| <b>12"</b><br>(305mm) | 6" (152mm)   | 15" (381mm)   | 30" (762mm)   | 18" (457mm)   |
|                       | 9" (229mm)   | 16½" (419mm)  | 33" (838mm)   | 21" (533mm)   |
|                       | 12" (305mm)  | 18" (457mm)   | 36" (914mm)   | 24" (610mm)   |
|                       | 18" (457mm)  | 21" (533mm)   | 42" (1067mm)  | 30" (762mm)   |
|                       | 24" (610mm)  | 24" (610mm)   | 48" (1219mm)  | 36" (914mm)   |
|                       | 30" (762mm)  | 27" (686mm)   | 54" (1372mm)  | 42" (1067mm)  |
|                       | 36" (914mm)  | 30" (762mm)   | 60" (1524mm)  | 48" (1219mm)  |
|                       | 42" (1067mm) | 33" (838mm)   | 66" (1676mm)  | 54" (1372mm)  |
| <b>24"</b><br>(610mm) | 48" (1219mm) | 36" (914mm)   | 72" (1829mm)  | 60" (1524mm)  |
|                       | 6" (152mm)   | 27" (686mm)   | 54" (1372mm)  | 30" (762mm)   |
|                       | 9" (229mm)   | 28½" (724mm)  | 57" (1448mm)  | 33" (838mm)   |
|                       | 12" (305mm)  | 30" (762mm)   | 60" (1524mm)  | 36" (914mm)   |
|                       | 18" (457mm)  | 33" (838mm)   | 66" (1676mm)  | 42" (1067mm)  |
|                       | 24" (610mm)  | 36" (914mm)   | 72" (1829mm)  | 48" (1219mm)  |
|                       | 30" (762mm)  | 39" (991mm)   | 78" (1981mm)  | 54" (1372mm)  |
|                       | 36" (914mm)  | 42" (1067mm)  | 84" (2134mm)  | 60" (1524mm)  |
| <b>36"</b><br>(914mm) | 42" (1067mm) | 45" (1143mm)  | 90" (2286mm)  | 66" (1676mm)  |
|                       | 48" (1219mm) | 48" (1219mm)  | 96" (2438mm)  | 72" (1829mm)  |
|                       | 6" (152mm)   | 39" (991mm)   | 78" (1981mm)  | 42" (1067mm)  |
|                       | 9" (229mm)   | 40½" (1029mm) | 81" (2057mm)  | 45" (1143mm)  |
|                       | 12" (305mm)  | 42" (1067mm)  | 84" (2134mm)  | 48" (1219mm)  |
|                       | 18" (457mm)  | 45" (1143mm)  | 90" (2286mm)  | 54" (1372mm)  |
|                       | 24" (610mm)  | 48" (1219mm)  | 96" (2438mm)  | 60" (1524mm)  |
|                       | 30" (762mm)  | 51" (1295mm)  | 102" (2591mm) | 66" (1676mm)  |
|                       | 36" (914mm)  | 54" (1372mm)  | 108" (2743mm) | 72" (1829mm)  |
|                       | 42" (1067mm) | 57" (1448mm)  | 114" (2896mm) | 78" (1981mm)  |
| 48" (1219mm)          | 60" (1524mm) | 120" (3048mm) | 84" (2134mm)  |               |

EXAMPLE: 238-12FT-12

**Note:** Nominal 9" rung spacing maintained through centerline of all fittings.

### Ordering Information:

See Page 62 for Electrical Grounding Chart

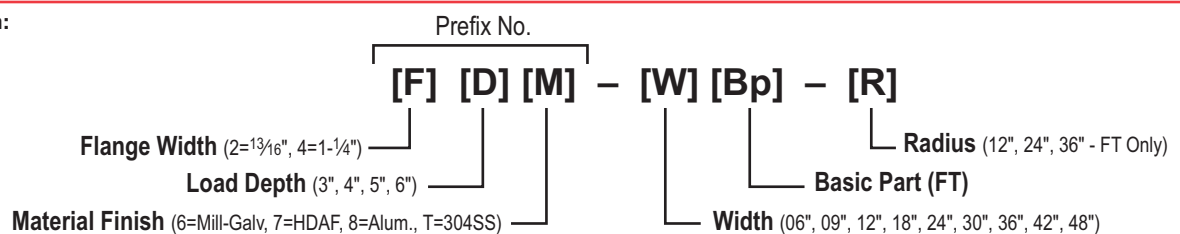

## Horizontal Cross [FC]

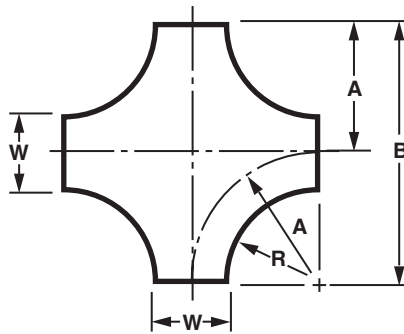
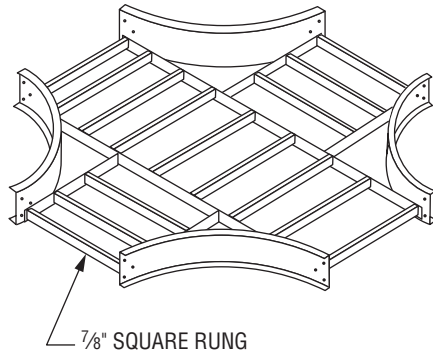

CSA Compliance for CSA Systems

| Radius - R             | Width - W    | "A" Dimension | "B" Dimension |
|------------------------|--------------|---------------|---------------|
| <b>12"<br/>(305mm)</b> | 6" (152mm)   | 15" (381mm)   | 30" (762mm)   |
|                        | 9" (229mm)   | 16½" (419mm)  | 33" (838mm)   |
|                        | 12" (305mm)  | 18" (457mm)   | 36" (914mm)   |
|                        | 18" (457mm)  | 21" (533mm)   | 42" (1067mm)  |
|                        | 24" (610mm)  | 24" (610mm)   | 48" (1219mm)  |
|                        | 30" (762mm)  | 27" (686mm)   | 54" (1372mm)  |
|                        | 36" (914mm)  | 30" (762mm)   | 60" (1524mm)  |
|                        | 42" (1067mm) | 33" (838mm)   | 66" (1676mm)  |
| <b>24"<br/>(610mm)</b> | 48" (1219mm) | 36" (914mm)   | 72" (1829mm)  |
|                        | 6" (152mm)   | 27" (686mm)   | 54" (1372mm)  |
|                        | 9" (229mm)   | 28½" (724mm)  | 57" (1448mm)  |
|                        | 12" (305mm)  | 30" (762mm)   | 60" (1524mm)  |
|                        | 18" (457mm)  | 33" (838mm)   | 66" (1676mm)  |
|                        | 24" (610mm)  | 36" (914mm)   | 72" (1829mm)  |
|                        | 30" (762mm)  | 39" (991mm)   | 78" (1981mm)  |
|                        | 36" (914mm)  | 42" (1067mm)  | 84" (2134mm)  |
| <b>36"<br/>(914mm)</b> | 42" (1067mm) | 45" (1143mm)  | 90" (2286mm)  |
|                        | 48" (1219mm) | 48" (1219mm)  | 96" (2438mm)  |
|                        | 6" (152mm)   | 39" (991mm)   | 78" (1981mm)  |
|                        | 9" (229mm)   | 40½" (1029mm) | 81" (2057mm)  |
|                        | 12" (305mm)  | 42" (1067mm)  | 84" (2134mm)  |
|                        | 18" (457mm)  | 45" (1143mm)  | 90" (2286mm)  |
|                        | 24" (610mm)  | 48" (1219mm)  | 96" (2438mm)  |
|                        | 30" (762mm)  | 51" (1295mm)  | 102" (2591mm) |
| <b>48" (1219mm)</b>    | 36" (914mm)  | 54" (1372mm)  | 108" (2743mm) |
|                        | 42" (1067mm) | 57" (1448mm)  | 114" (2896mm) |
|                        | 48" (1219mm) | 60" (1524mm)  | 120" (3048mm) |

EXAMPLE: 238-12FC-12

**Note:** Nominal 9" rung spacing maintained through centerline of all fittings.

### Ordering Information:

See Page 62  
for Electrical  
Grounding Chart

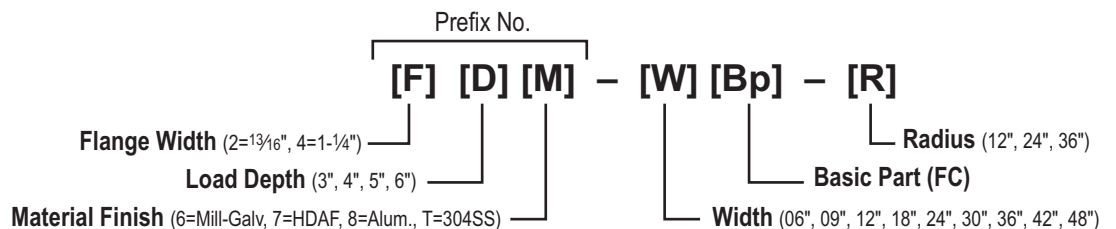

## Horizontal Tapped Tee [TT]

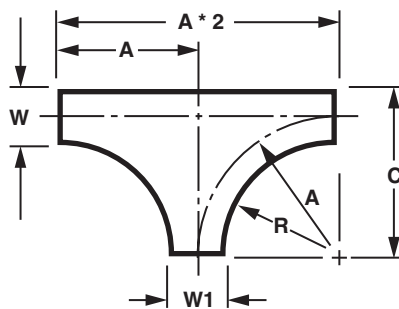
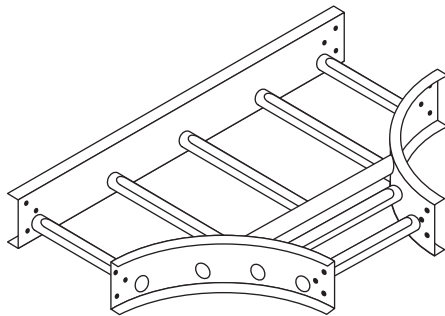

CSA Compliance for CSA Systems

| R Radius              | W Width                | W1 Width     | "A" Dimension   | "C" Dimension   |
|-----------------------|------------------------|--------------|-----------------|-----------------|
| <b>12"</b><br>(305mm) | <b>48"</b><br>(1219mm) | 42" (1067mm) | 33" (838mm)     | 60"<br>(1524mm) |
|                       |                        | 36" (914mm)  | 30" (762mm)     |                 |
|                       |                        | 30" (762mm)  | 27" (686mm)     |                 |
|                       |                        | 24" (610mm)  | 24" (610mm)     |                 |
|                       |                        | 18" (457mm)  | 21" (533mm)     |                 |
|                       |                        | 12" (305mm)  | 18" (457mm)     |                 |
|                       | <b>42"</b><br>(1067mm) | 9" (229mm)   | 16½" (419mm)    | 54"<br>(1372mm) |
|                       |                        | 6" (152mm)   | 15" (381mm)     |                 |
|                       |                        | 36" (914mm)  | 30" (762mm)     |                 |
|                       |                        | 30" (762mm)  | 27" (686mm)     |                 |
|                       |                        | 24" (610mm)  | 24" (610mm)     |                 |
|                       |                        | 18" (457mm)  | 21" (533mm)     |                 |
| <b>36"</b><br>(914mm) | 12" (305mm)            | 18" (457mm)  | 48"<br>(1219mm) |                 |
|                       | 9" (229mm)             | 16½" (419mm) |                 |                 |
|                       | 6" (152mm)             | 15" (381mm)  |                 |                 |
|                       | 30" (762mm)            | 27" (686mm)  |                 |                 |
|                       | 24" (610mm)            | 24" (610mm)  |                 |                 |
|                       | 18" (457mm)            | 21" (533mm)  |                 |                 |
| <b>30"</b><br>(762mm) | 12" (305mm)            | 18" (457mm)  | 42"<br>(1067mm) |                 |
|                       | 9" (229mm)             | 16½" (419mm) |                 |                 |
|                       | 6" (152mm)             | 15" (381mm)  |                 |                 |
|                       | 18" (457mm)            | 21" (533mm)  |                 |                 |
| <b>24"</b><br>(610mm) | 12" (305mm)            | 18" (457mm)  | 36"<br>(914mm)  |                 |
|                       | 9" (229mm)             | 16½" (419mm) |                 |                 |
|                       | 6" (152mm)             | 15" (381mm)  |                 |                 |
|                       | 12" (305mm)            | 18" (457mm)  |                 |                 |
| <b>18"</b><br>(457mm) | 9" (229mm)             | 16½" (419mm) | 30"<br>(762mm)  |                 |
|                       | 6" (152mm)             | 15" (381mm)  |                 |                 |
|                       | 12" (305mm)            | 18" (457mm)  |                 |                 |
| <b>12"</b><br>(305mm) | 9" (229mm)             | 16½" (419mm) | 24"<br>(610mm)  |                 |
|                       | 6" (152mm)             | 15" (381mm)  |                 |                 |
| <b>9"</b><br>(229mm)  | 6" (152mm)             | 15" (381mm)  | 21"<br>(533mm)  |                 |

EXAMPLE: 238-12TT-09-12

**Note:** Nominal 9" rung spacing maintained through centerline of all fittings.

**Ordering Information:**

See Page 62 for Electrical Grounding Chart

Prefix No.

**[F] [D] [M] – [W] [Bp] – [W1]– [R]**

**Flange Width** (2=1¾", 4=1-¼")

**Load Depth** (3", 4", 5", 6", 7")

**Material Finish** (6=Mill-Galv, 7=HDAF, 8=Alum., T=304SS)

**Radius** (12", 24", 36")

**Width** (06", 09", 12", 18", 24", 30", 36", 42", 48")

**Basic Part (TT)**

**Width** (06", 09", 12", 18", 24", 30", 36", 42", 48")

## Horizontal Tapped Tee [TT] (cont.)

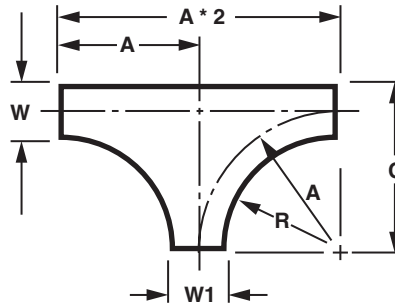

**CSA Compliance for CSA Systems**

| R Radius       | W Width         | W1 Width     | "A" Dimension   | "C" Dimension   |                 |
|----------------|-----------------|--------------|-----------------|-----------------|-----------------|
| 24"<br>(610mm) | 48"<br>(1219mm) | 42" (1067mm) | 45" (1143mm)    | 72"<br>(1829mm) |                 |
|                |                 | 36" (914mm)  | 42" (1067mm)    |                 |                 |
|                |                 | 30" (762mm)  | 39" (991mm)     |                 |                 |
|                |                 | 24" (610mm)  | 36" (914mm)     |                 |                 |
|                |                 | 18" (457mm)  | 33" (838mm)     |                 |                 |
|                |                 | 12" (305mm)  | 30" (762mm)     |                 |                 |
|                | 42"<br>(1067mm) | 9" (229mm)   | 28½" (724mm)    | 66"<br>(1676mm) |                 |
|                |                 | 6" (152mm)   | 27" (686mm)     |                 |                 |
|                |                 | 36" (914mm)  | 42" (1067mm)    |                 | 60"<br>(1524mm) |
|                |                 | 30" (762mm)  | 39" (991mm)     |                 |                 |
|                |                 | 24" (610mm)  | 36" (914mm)     |                 |                 |
|                |                 | 18" (457mm)  | 33" (838mm)     |                 |                 |
| 12" (305mm)    | 30" (762mm)     |              |                 |                 |                 |
| 36"<br>(914mm) | 9" (229mm)      | 28½" (724mm) | 54"<br>(1372mm) |                 |                 |
|                | 6" (152mm)      | 27" (686mm)  |                 |                 |                 |
|                | 24" (610mm)     | 36" (914mm)  |                 | 48"<br>(1219mm) |                 |
|                | 18" (457mm)     | 33" (838mm)  |                 |                 |                 |
|                | 12" (305mm)     | 30" (762mm)  |                 |                 |                 |
|                | 9" (229mm)      | 28½" (724mm) |                 |                 |                 |
| 30"<br>(762mm) | 6" (152mm)      | 27" (686mm)  | 42"<br>(1067mm) |                 |                 |
|                | 18" (457mm)     | 33" (838mm)  |                 |                 |                 |
|                | 12" (305mm)     | 30" (762mm)  |                 |                 |                 |
| 24"<br>(610mm) | 9" (229mm)      | 28½" (724mm) | 36"<br>(914mm)  |                 |                 |
|                | 6" (152mm)      | 27" (686mm)  |                 |                 |                 |
| 18"<br>(457mm) | 9" (229mm)      | 28½" (724mm) | 33"<br>(838mm)  |                 |                 |
|                | 6" (152mm)      | 27" (686mm)  |                 |                 |                 |
| 12"<br>(305mm) | 9" (229mm)      | 28½" (724mm) | 36"<br>(914mm)  |                 |                 |
|                | 6" (152mm)      | 27" (686mm)  |                 |                 |                 |
| 9"<br>(229mm)  | 6" (152mm)      | 27" (686mm)  | 33"<br>(838mm)  |                 |                 |
|                | 6" (152mm)      | 27" (686mm)  |                 |                 |                 |

**CSA Compliance for CSA Systems**

| R Radius       | W Width         | W1 Width      | "A" Dimension   | "C" Dimension   |                 |
|----------------|-----------------|---------------|-----------------|-----------------|-----------------|
| 36"<br>(914mm) | 48"<br>(1219mm) | 42" (1067mm)  | 57" (1448mm)    | 84"<br>(2134mm) |                 |
|                |                 | 36" (914mm)   | 54" (1372mm)    |                 |                 |
|                |                 | 30" (762mm)   | 51" (1295mm)    |                 |                 |
|                |                 | 24" (610mm)   | 48" (1219mm)    |                 |                 |
|                |                 | 18" (457mm)   | 45" (1143mm)    |                 |                 |
|                |                 | 12" (305mm)   | 42" (1067mm)    |                 |                 |
|                | 42"<br>(1067mm) | 9" (229mm)    | 40½" (1029mm)   | 78"<br>(1981mm) |                 |
|                |                 | 6" (152mm)    | 39" (991mm)     |                 |                 |
|                |                 | 36" (914mm)   | 54" (1372mm)    |                 | 72"<br>(1829mm) |
|                |                 | 30" (762mm)   | 51" (1295mm)    |                 |                 |
|                |                 | 24" (610mm)   | 48" (1219mm)    |                 |                 |
|                |                 | 18" (457mm)   | 45" (1143mm)    |                 |                 |
| 12" (305mm)    | 42" (1067mm)    |               |                 |                 |                 |
| 36"<br>(914mm) | 9" (229mm)      | 40½" (1029mm) | 66"<br>(1676mm) |                 |                 |
|                | 6" (152mm)      | 39" (991mm)   |                 |                 |                 |
|                | 30" (762mm)     | 51" (1295mm)  |                 | 60"<br>(1524mm) |                 |
|                | 24" (610mm)     | 48" (1219mm)  |                 |                 |                 |
|                | 18" (457mm)     | 45" (1143mm)  |                 |                 |                 |
|                | 12" (305mm)     | 42" (1067mm)  |                 |                 |                 |
| 30"<br>(762mm) | 9" (229mm)      | 40½" (1029mm) | 54"<br>(1372mm) |                 |                 |
|                | 6" (152mm)      | 39" (991mm)   |                 |                 |                 |
|                | 18" (457mm)     | 45" (1143mm)  |                 |                 |                 |
| 24"<br>(610mm) | 12" (305mm)     | 42" (1067mm)  | 48"<br>(1219mm) |                 |                 |
|                | 9" (229mm)      | 40½" (1029mm) |                 |                 |                 |
|                | 6" (152mm)      | 39" (991mm)   |                 |                 |                 |
| 18"<br>(457mm) | 12" (305mm)     | 42" (1067mm)  | 45"<br>(1143mm) |                 |                 |
|                | 9" (229mm)      | 40½" (1029mm) |                 |                 |                 |
|                | 6" (152mm)      | 39" (991mm)   |                 |                 |                 |
| 12"<br>(305mm) | 9" (229mm)      | 40½" (1029mm) | 48"<br>(1219mm) |                 |                 |
|                | 6" (152mm)      | 39" (991mm)   |                 |                 |                 |
| 9"<br>(229mm)  | 6" (152mm)      | 39" (991mm)   | 45"<br>(1143mm) |                 |                 |
|                | 6" (152mm)      | 39" (991mm)   |                 |                 |                 |

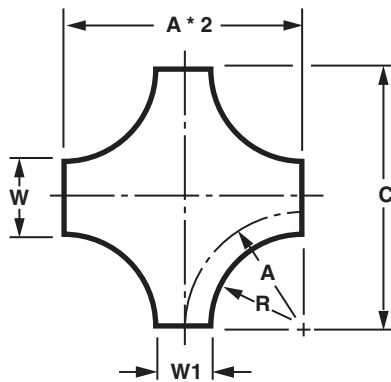
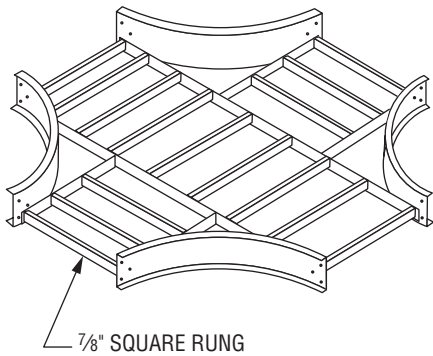
## Horizontal Tapped Cross [TC]



CSA Compliance for CSA Systems

| R Radius       | W Width         | W1 Width        | "A" Dimension   | "C" Dimension   |
|----------------|-----------------|-----------------|-----------------|-----------------|
| 12"<br>(305mm) | 48"<br>(1219mm) | 42" (1067mm)    | 33" (838mm)     | 72"<br>(1829mm) |
|                |                 | 36" (914mm)     | 30" (762mm)     |                 |
|                |                 | 30" (762mm)     | 27" (686mm)     |                 |
|                |                 | 24" (610mm)     | 24" (610mm)     |                 |
|                |                 | 18" (457mm)     | 21" (533mm)     |                 |
|                |                 | 12" (305mm)     | 18" (457mm)     |                 |
|                |                 | 9" (229mm)      | 16 1/2" (419mm) |                 |
|                | 6" (152mm)      | 15" (381mm)     |                 |                 |
|                | 42"<br>(1067mm) | 36" (914mm)     | 30" (762mm)     | 66"<br>(1676mm) |
|                |                 | 30" (762mm)     | 27" (686mm)     |                 |
|                |                 | 24" (610mm)     | 24" (610mm)     |                 |
|                |                 | 18" (457mm)     | 21" (533mm)     |                 |
|                |                 | 12" (305mm)     | 18" (457mm)     |                 |
|                |                 | 9" (229mm)      | 16 1/2" (419mm) |                 |
| 6" (152mm)     |                 | 15" (381mm)     |                 |                 |
| 36"<br>(914mm) | 30" (762mm)     | 27" (686mm)     | 60"<br>(1524mm) |                 |
|                | 24" (610mm)     | 24" (610mm)     |                 |                 |
|                | 18" (457mm)     | 21" (533mm)     |                 |                 |
|                | 12" (305mm)     | 18" (457mm)     |                 |                 |
|                | 9" (229mm)      | 16 1/2" (419mm) |                 |                 |
|                | 6" (152mm)      | 15" (381mm)     |                 |                 |
|                | 30"<br>(762mm)  | 24" (610mm)     |                 | 24" (610mm)     |
| 18" (457mm)    |                 | 21" (533mm)     |                 |                 |
| 12" (305mm)    |                 | 18" (457mm)     |                 |                 |
| 9" (229mm)     |                 | 16 1/2" (419mm) |                 |                 |
| 24"<br>(610mm) | 18" (457mm)     | 21" (533mm)     | 48"<br>(1219mm) |                 |
|                | 12" (305mm)     | 18" (457mm)     |                 |                 |
|                | 9" (229mm)      | 16 1/2" (419mm) |                 |                 |
|                | 6" (152mm)      | 15" (381mm)     |                 |                 |
| 18"<br>(457mm) | 12" (305mm)     | 18" (457mm)     | 42"<br>(1067mm) |                 |
|                | 9" (229mm)      | 16 1/2" (419mm) |                 |                 |
|                | 6" (152mm)      | 15" (381mm)     |                 |                 |
| 12"<br>(305mm) | 9" (229mm)      | 16 1/2" (419mm) | 36"<br>(914mm)  |                 |
|                | 6" (152mm)      | 15" (381mm)     |                 |                 |
| 9"<br>(229mm)  | 6" (152mm)      | 15" (381mm)     | 33"<br>(838mm)  |                 |

EXAMPLE: 238-36TC-18-12

**Note:** Nominal 9" rung spacing maintained through centerline of all fittings.

**Ordering Information:**

See Page 62 for Electrical Grounding Chart

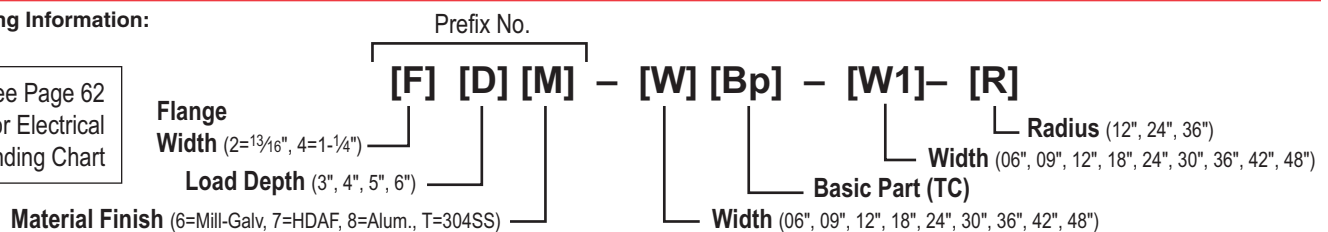

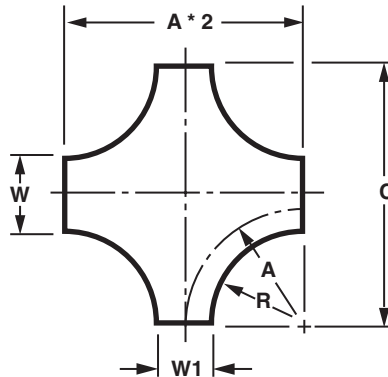
**Horizontal Tapped Cross [TC] (cont.)**

**CSA Compliance for CSA Systems**

| R Radius              | W Width                | W1 Width     | "A" Dimension   | "C" Dimension   |                 |
|-----------------------|------------------------|--------------|-----------------|-----------------|-----------------|
| <b>24"</b><br>(610mm) | <b>48"</b><br>(1219mm) | 42" (1067mm) | 45" (1143mm)    | 96"<br>(2438mm) |                 |
|                       |                        | 36" (914mm)  | 42" (1067mm)    |                 |                 |
|                       |                        | 30" (762mm)  | 39" (991mm)     |                 |                 |
|                       |                        | 24" (610mm)  | 36" (914mm)     |                 |                 |
|                       |                        | 18" (457mm)  | 33" (838mm)     |                 |                 |
|                       |                        | 12" (305mm)  | 30" (762mm)     |                 |                 |
|                       | <b>42"</b><br>(1067mm) | 9" (229mm)   | 28½" (724mm)    | 90"<br>(2286mm) |                 |
|                       |                        | 6" (152mm)   | 27" (686mm)     |                 |                 |
|                       |                        | 36" (914mm)  | 42" (1067mm)    |                 | 84"<br>(2134mm) |
|                       |                        | 30" (762mm)  | 39" (991mm)     |                 |                 |
|                       |                        | 24" (610mm)  | 36" (914mm)     |                 |                 |
|                       |                        | 18" (457mm)  | 33" (838mm)     |                 |                 |
| 12" (305mm)           | 30" (762mm)            |              |                 |                 |                 |
| <b>36"</b><br>(914mm) | 9" (229mm)             | 28½" (724mm) | 78"<br>(1981mm) |                 |                 |
|                       | 6" (152mm)             | 27" (686mm)  |                 |                 |                 |
|                       | 24" (610mm)            | 36" (914mm)  |                 | 72"<br>(1829mm) |                 |
|                       | 18" (457mm)            | 33" (838mm)  |                 |                 |                 |
|                       | 12" (305mm)            | 30" (762mm)  |                 |                 |                 |
|                       | 9" (229mm)             | 28½" (724mm) |                 |                 | 66"<br>(1676mm) |
| 6" (152mm)            | 27" (686mm)            |              |                 |                 |                 |
| <b>30"</b><br>(762mm) | 12" (305mm)            | 30" (762mm)  | 60"<br>(1524mm) |                 |                 |
|                       | 9" (229mm)             | 28½" (724mm) |                 |                 |                 |
|                       | 6" (152mm)             | 27" (686mm)  |                 |                 |                 |
| <b>24"</b><br>(610mm) | 12" (305mm)            | 30" (762mm)  | 60"<br>(1524mm) |                 |                 |
|                       | 9" (229mm)             | 28½" (724mm) |                 |                 |                 |
|                       | 6" (152mm)             | 27" (686mm)  |                 |                 |                 |
| <b>18"</b><br>(457mm) | 12" (305mm)            | 30" (762mm)  | 66"<br>(1676mm) |                 |                 |
|                       | 9" (229mm)             | 28½" (724mm) |                 |                 |                 |
|                       | 6" (152mm)             | 27" (686mm)  |                 |                 |                 |
| <b>12"</b><br>(305mm) | 9" (229mm)             | 28½" (724mm) | 60"<br>(1524mm) |                 |                 |
|                       | 6" (152mm)             | 27" (686mm)  |                 |                 |                 |
|                       | 6" (152mm)             | 27" (686mm)  |                 |                 |                 |
| <b>9"</b><br>(229mm)  | 6" (152mm)             | 27" (686mm)  | 57"<br>(1448mm) |                 |                 |

**CSA Compliance for CSA Systems**

| R Radius              | W Width                | W1 Width      | "A" Dimension    | "C" Dimension    |                  |
|-----------------------|------------------------|---------------|------------------|------------------|------------------|
| <b>36"</b><br>(914mm) | <b>48"</b><br>(1219mm) | 42" (1067mm)  | 57" (1448mm)     | 120"<br>(3048mm) |                  |
|                       |                        | 36" (914mm)   | 54" (1372mm)     |                  |                  |
|                       |                        | 30" (762mm)   | 51" (1295mm)     |                  |                  |
|                       |                        | 24" (610mm)   | 48" (1219mm)     |                  |                  |
|                       |                        | 18" (457mm)   | 45" (1143mm)     |                  |                  |
|                       |                        | 12" (305mm)   | 42" (1067mm)     |                  |                  |
|                       | <b>42"</b><br>(1067mm) | 9" (229mm)    | 40½" (1029mm)    | 114"<br>(2896mm) |                  |
|                       |                        | 6" (152mm)    | 39" (991mm)      |                  |                  |
|                       |                        | 36" (914mm)   | 54" (1372mm)     |                  | 108"<br>(2743mm) |
|                       |                        | 30" (762mm)   | 51" (1295mm)     |                  |                  |
|                       |                        | 24" (610mm)   | 48" (1219mm)     |                  |                  |
|                       |                        | 18" (457mm)   | 45" (1143mm)     |                  |                  |
| 12" (305mm)           | 42" (1067mm)           |               |                  |                  |                  |
| <b>36"</b><br>(914mm) | 9" (229mm)             | 40½" (1029mm) | 102"<br>(2591mm) |                  |                  |
|                       | 6" (152mm)             | 39" (991mm)   |                  |                  |                  |
|                       | 24" (610mm)            | 48" (1219mm)  |                  | 96"<br>(2438mm)  |                  |
|                       | 18" (457mm)            | 45" (1143mm)  |                  |                  |                  |
|                       | 12" (305mm)            | 42" (1067mm)  |                  |                  |                  |
|                       | 9" (229mm)             | 40½" (1029mm) |                  |                  | 90"<br>(2286mm)  |
| 6" (152mm)            | 39" (991mm)            |               |                  |                  |                  |
| <b>30"</b><br>(762mm) | 12" (305mm)            | 42" (1067mm)  | 84"<br>(2134mm)  |                  |                  |
|                       | 9" (229mm)             | 40½" (1029mm) |                  |                  |                  |
|                       | 6" (152mm)             | 39" (991mm)   |                  |                  |                  |
| <b>24"</b><br>(610mm) | 12" (305mm)            | 42" (1067mm)  | 96"<br>(2438mm)  |                  |                  |
|                       | 9" (229mm)             | 40½" (1029mm) |                  |                  |                  |
|                       | 6" (152mm)             | 39" (991mm)   |                  |                  |                  |
| <b>18"</b><br>(457mm) | 12" (305mm)            | 42" (1067mm)  | 90"<br>(2286mm)  |                  |                  |
|                       | 9" (229mm)             | 40½" (1029mm) |                  |                  |                  |
|                       | 6" (152mm)             | 39" (991mm)   |                  |                  |                  |
| <b>12"</b><br>(305mm) | 9" (229mm)             | 40½" (1029mm) | 84"<br>(2134mm)  |                  |                  |
|                       | 6" (152mm)             | 39" (991mm)   |                  |                  |                  |
|                       | 6" (152mm)             | 39" (991mm)   |                  |                  |                  |
| <b>9"</b><br>(229mm)  | 6" (152mm)             | 39" (991mm)   | 81"<br>(2057mm)  |                  |                  |

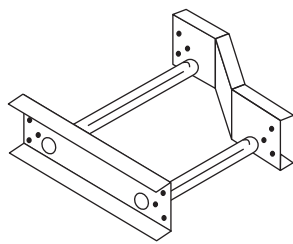
## Left Hand [LH] & Right Hand [RH] Reducer



RIGHT HAND (RH)

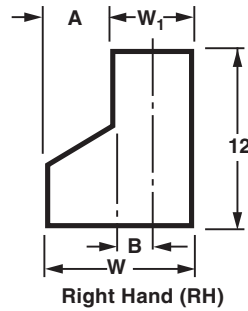

Right Hand (RH)

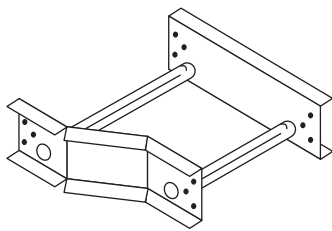

LEFT HAND (LH)

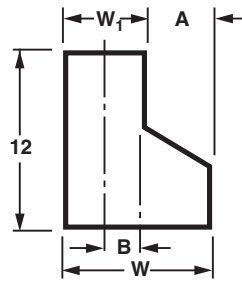

Left Hand (LH)

### CSA Compliance for CSA Systems

| Width - W              | "W1" Dim.             | "A" Dim.     | "B" Dim.       |
|------------------------|-----------------------|--------------|----------------|
| <b>48"</b><br>(1219mm) | 42" (1067mm)          | 6" (152mm)   | 21" (533mm)    |
|                        | 36" (914mm)           | 12" (305mm)  | 18" (457mm)    |
|                        | 30" (762mm)           | 18" (457mm)  | 15" (381mm)    |
|                        | 24" (610mm)           | 24" (610mm)  | 12" (305mm)    |
|                        | 18" (457mm)           | 30" (762mm)  | 9" (229mm)     |
|                        | 12" (305mm)           | 36" (914mm)  | 6" (152mm)     |
|                        | 9" (229mm)            | 39" (991mm)  | 4 1/2" (114mm) |
|                        | 6" (152mm)            | 42" (1067mm) | 3" (76mm)      |
| <b>42"</b><br>(1067mm) | 36" (914mm)           | 6" (152mm)   | 18" (457mm)    |
|                        | 30" (762mm)           | 12" (305mm)  | 15" (381mm)    |
|                        | 24" (610mm)           | 18" (457mm)  | 12" (305mm)    |
|                        | 18" (457mm)           | 24" (610mm)  | 9" (229mm)     |
|                        | 12" (305mm)           | 30" (762mm)  | 6" (152mm)     |
|                        | 9" (229mm)            | 33" (838mm)  | 4 1/2" (114mm) |
|                        | 6" (152mm)            | 36" (914mm)  | 3" (76mm)      |
|                        | <b>36"</b><br>(914mm) | 30" (762mm)  | 6" (152mm)     |
| 24" (610mm)            |                       | 12" (305mm)  | 12" (305mm)    |
| 18" (457mm)            |                       | 18" (457mm)  | 9" (229mm)     |
| 12" (305mm)            |                       | 24" (610mm)  | 6" (152mm)     |
| 9" (229mm)             |                       | 27" (686mm)  | 4 1/2" (114mm) |
| 6" (152mm)             |                       | 30" (762mm)  | 3" (76mm)      |
| <b>30"</b><br>(762mm)  | 24" (610mm)           | 6" (152mm)   | 12" (305mm)    |
|                        | 18" (457mm)           | 12" (305mm)  | 9" (229mm)     |
|                        | 12" (305mm)           | 18" (457mm)  | 6" (152mm)     |
|                        | 9" (229mm)            | 21" (533mm)  | 4 1/2" (114mm) |
|                        | 6" (152mm)            | 24" (610mm)  | 3" (76mm)      |
| <b>24"</b><br>(610mm)  | 18" (457mm)           | 6" (152mm)   | 9" (229mm)     |
|                        | 12" (305mm)           | 12" (305mm)  | 6" (152mm)     |
|                        | 9" (229mm)            | 15" (381mm)  | 4 1/2" (114mm) |
|                        | 6" (152mm)            | 18" (457mm)  | 3" (76mm)      |
| <b>18"</b><br>(457mm)  | 12" (305mm)           | 6" (152mm)   | 6" (152mm)     |
|                        | 9" (229mm)            | 9" (229mm)   | 4 1/2" (114mm) |
|                        | 6" (152mm)            | 12" (305mm)  | 3" (76mm)      |
| <b>12"</b><br>(305mm)  | 9" (229mm)            | 3" (76mm)    | 4 1/2" (114mm) |
|                        | 6" (152mm)            | 6" (152mm)   | 3" (76mm)      |
| <b>9"</b><br>(229mm)   | 6" (152mm)            | 3" (76mm)    | 3" (76mm)      |

EXAMPLE: 238-12LH-06

**Note:** Nominal 9" rung spacing maintained through centerline of all fittings.

### Ordering Information:

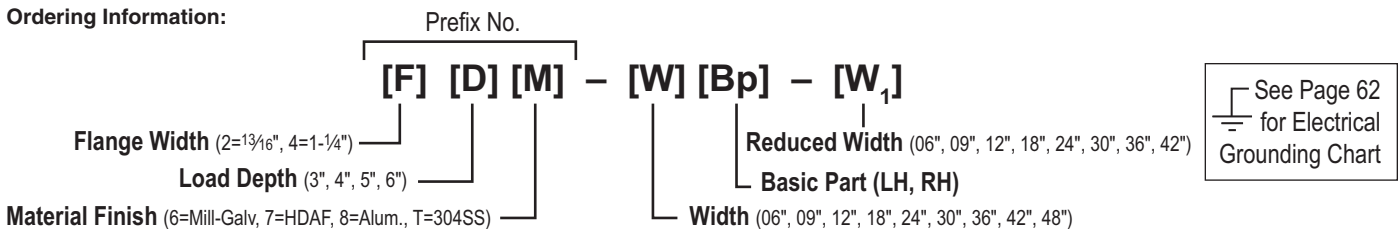

## Straight Reducer [ST]

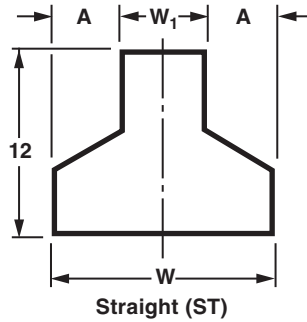
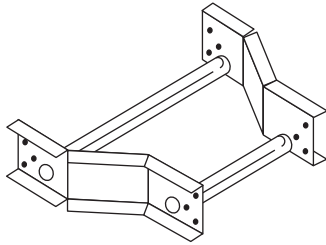

### CSA Compliance for CSA Systems

| Width - W              | Width - W1   | "A" Dimension   |
|------------------------|--------------|-----------------|
| <b>48"</b><br>(1219mm) | 42" (1067mm) | 3" (76mm)       |
|                        | 36" (914mm)  | 6" (152mm)      |
|                        | 30" (762mm)  | 9" (229mm)      |
|                        | 24" (610mm)  | 12" (305mm)     |
|                        | 18" (457mm)  | 15" (381mm)     |
|                        | 12" (305mm)  | 18" (457mm)     |
| <b>42"</b><br>(1067mm) | 36" (914mm)  | 3" (76mm)       |
|                        | 30" (762mm)  | 6" (152mm)      |
|                        | 24" (610mm)  | 9" (229mm)      |
|                        | 18" (457mm)  | 12" (305mm)     |
|                        | 12" (305mm)  | 15" (381mm)     |
|                        | 9" (229mm)   | 16 1/2" (419mm) |
| <b>36"</b><br>(914mm)  | 30" (762mm)  | 3" (76mm)       |
|                        | 24" (610mm)  | 6" (152mm)      |
|                        | 18" (457mm)  | 9" (229mm)      |
|                        | 12" (305mm)  | 12" (305mm)     |
|                        | 9" (229mm)   | 13 1/2" (343mm) |
|                        | 6" (152mm)   | 15" (381mm)     |
| <b>30"</b><br>(762mm)  | 24" (610mm)  | 3" (76mm)       |
|                        | 18" (457mm)  | 6" (152mm)      |
|                        | 12" (305mm)  | 9" (229mm)      |
|                        | 9" (229mm)   | 10 1/2" (267mm) |
|                        | 6" (152mm)   | 12" (304mm)     |
| <b>24"</b><br>(610mm)  | 18" (457mm)  | 3" (76mm)       |
|                        | 12" (305mm)  | 6" (152mm)      |
|                        | 9" (229mm)   | 7 1/2" (191mm)  |
|                        | 6" (152mm)   | 9" (229mm)      |
| <b>18"</b><br>(457mm)  | 12" (305mm)  | 3" (76mm)       |
|                        | 9" (229mm)   | 4 1/2" (114mm)  |
|                        | 6" (152mm)   | 6" (152mm)      |
| <b>12"</b><br>(305mm)  | 9" (229mm)   | 1 1/2" (38mm)   |
|                        | 6" (152mm)   | 3" (76mm)       |
| <b>9"</b><br>(229mm)   | 6" (152mm)   | 1 1/2" (38mm)   |

EXAMPLE: 238-12ST-06

**Note:** Nominal 9" rung spacing maintained through centerline of all fittings.

### Ordering Information:

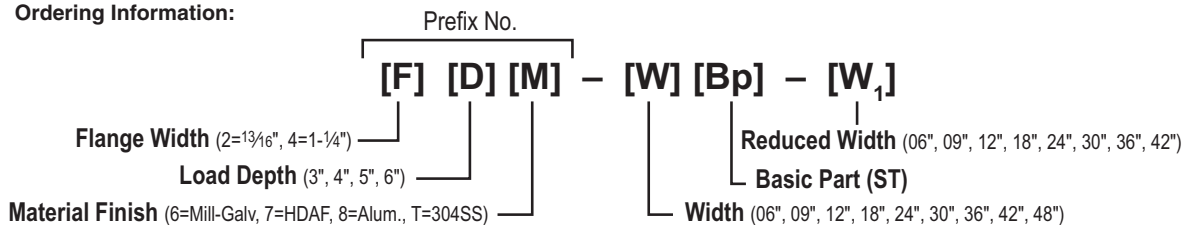

See Page 62  
for Electrical  
Grounding Chart

# LADDER CABLE TRAY SYSTEM

## 45° "Y" Branch Left Hand [LY] & Right Hand [RY]

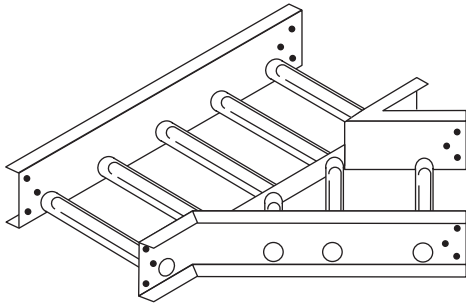

| Width - W    | "A" Dim.         | "B" Dim.         | "C" Dim.         | "D" Dim.         |
|--------------|------------------|------------------|------------------|------------------|
| 6" (152mm)   | 22 1/2" (571mm)  | 16 1/4" (413mm)  | 9 1/4" (235mm)   | 11 1/8" (283mm)  |
| 9" (229mm)   | 26 3/4" (679mm)  | 21 3/8" (543mm)  | 9 13/16" (249mm) | 13 3/4" (349mm)  |
| 12" (305mm)  | 31" (787mm)      | 26 1/2" (673mm)  | 10 1/2" (267mm)  | 16 1/4" (412mm)  |
| 18" (457mm)  | 39 1/2" (1003mm) | 36 3/4" (933mm)  | 11 3/4" (298mm)  | 21 3/8" (543mm)  |
| 24" (610mm)  | 48" (1219mm)     | 47" (1193mm)     | 13" (330mm)      | 26 1/2" (673mm)  |
| 30" (762mm)  | 56 3/8" (1432mm) | 57 1/4" (1454mm) | 14 1/8" (359mm)  | 31 5/8" (803mm)  |
| 36" (914mm)  | 65" (1651mm)     | 67 1/2" (1714mm) | 15 1/2" (394mm)  | 36 3/4" (933mm)  |
| 42" (1067mm) | 73 3/8" (1864mm) | 77 5/8" (1972mm) | 16 3/4" (425mm)  | 41 3/4" (1060mm) |
| 48" (1219mm) | 81 7/8" (2080mm) | 87 7/8" (2232mm) | 18" (457mm)      | 46 7/8" (1191mm) |

EXAMPLE: 238-12LY

### RIGHT HAND (RY) SHOWN

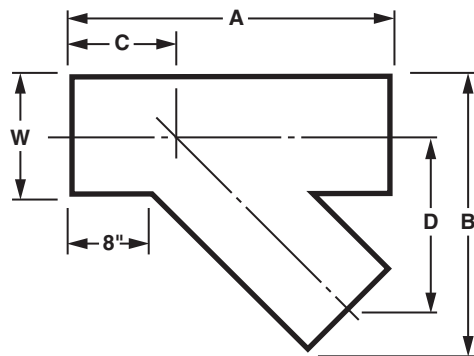

## Adjustable Elbow [AF]

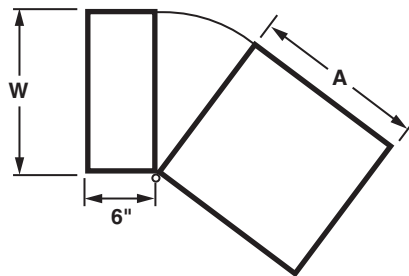
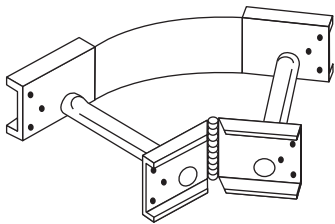

| Width - W    | "A" Dimension |
|--------------|---------------|
| 6" (152mm)   | 8" (203mm)    |
| 9" (229mm)   | 11" (279mm)   |
| 12" (305mm)  | 14" (356mm)   |
| 18" (457mm)  | 20" (508mm)   |
| 24" (610mm)  | 26" (660mm)   |
| 30" (762mm)  | 32" (813mm)   |
| 36" (914mm)  | 38" (965mm)   |
| 42" (1067mm) | 44" (1118mm)  |
| 48" (1219mm) | 50" (1270mm)  |

EXAMPLE: 238-12AF

**Note:** Nominal 9" rung spacing maintained through centerline of all fittings.

### Ordering Information:

See Page 62 for Electrical Grounding Chart

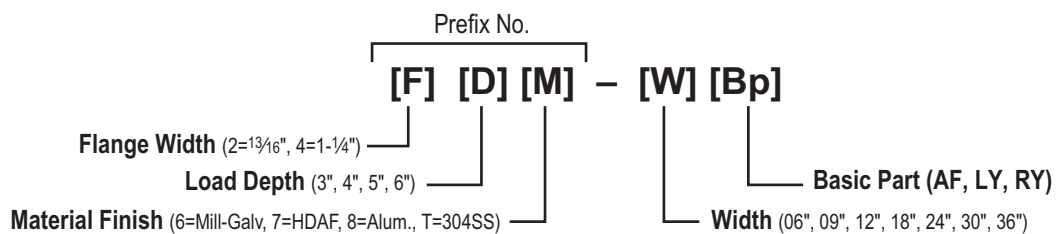

## 90° Vertical Elbow Outside [90] & Inside [9I]

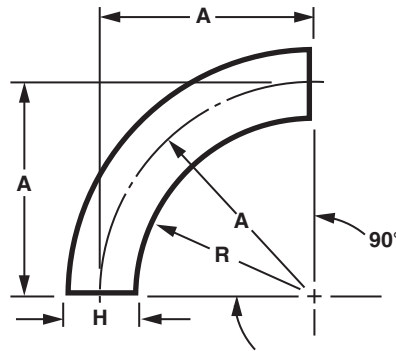
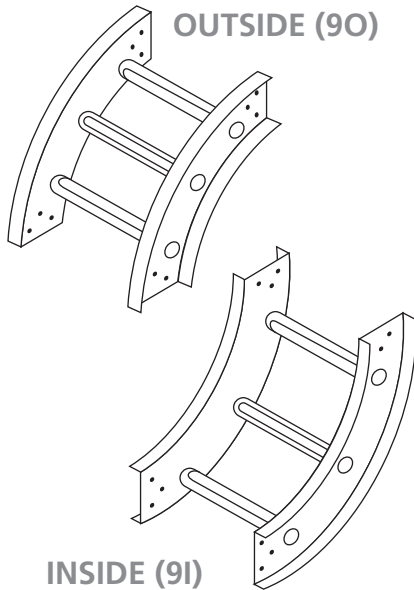

| CSA Compliance for CSA Systems |                |                  |
|--------------------------------|----------------|------------------|
| Radius - R                     | "H" Dim.       | "A" Dim.         |
| <b>12"</b><br>(305mm)          | 4 1/4" (108mm) | 14 1/8" (359mm)  |
|                                | 5 1/4" (133mm) | 14 5/8" (372mm)  |
|                                | 6 1/4" (159mm) | 15 1/8" (384mm)  |
| <b>24"</b><br>(610mm)          | 7 1/4" (184mm) | 15 5/8" (397mm)  |
|                                | 4 1/4" (108mm) | 26 1/8" (664mm)  |
|                                | 5 1/4" (133mm) | 26 5/8" (676mm)  |
| <b>36"</b><br>(914mm)          | 6 1/4" (159mm) | 27 1/8" (689mm)  |
|                                | 7 1/4" (184mm) | 27 5/8" (702mm)  |
|                                | 4 1/4" (108mm) | 38 1/8" (969mm)  |
|                                | 5 1/4" (133mm) | 38 5/8" (981mm)  |
|                                | 6 1/4" (159mm) | 39 1/8" (994mm)  |
|                                | 7 1/4" (184mm) | 39 5/8" (1007mm) |

EXAMPLE: 238-1290-12

## 60° Vertical Elbow Outside [60] & Inside [6I]

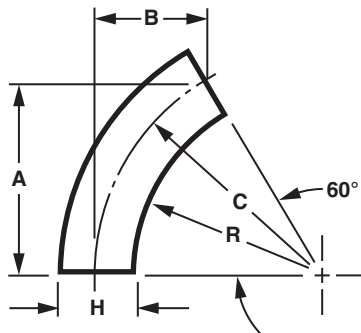

| CSA Compliance for CSA Systems |                |                 |                 |                  |
|--------------------------------|----------------|-----------------|-----------------|------------------|
| Radius - R                     | "H" Dim.       | "A" Dim.        | "B" Dim.        | "C" Dim.         |
| <b>12"</b><br>(305mm)          | 4 1/4" (108mm) | 12 1/4" (311mm) | 7 1/8" (181mm)  | 14 1/8" (359mm)  |
|                                | 5 1/4" (133mm) | 12 5/8" (321mm) | 7 3/8" (187mm)  | 14 5/8" (372mm)  |
|                                | 6 1/4" (159mm) | 13 1/8" (334mm) | 7 5/8" (194mm)  | 15 1/8" (384mm)  |
| <b>24"</b><br>(610mm)          | 7 1/4" (184mm) | 13 1/2" (343mm) | 7 7/8" (200mm)  | 15 5/8" (397mm)  |
|                                | 4 1/4" (108mm) | 22 5/8" (575mm) | 13 1/8" (334mm) | 26 1/8" (664mm)  |
|                                | 5 1/4" (133mm) | 23 1/8" (588mm) | 13 3/8" (340mm) | 26 5/8" (676mm)  |
| <b>36"</b><br>(914mm)          | 6 1/4" (159mm) | 23 1/2" (597mm) | 13" (330mm)     | 27 1/8" (689mm)  |
|                                | 7 1/4" (184mm) | 24" (610mm)     | 1 7/8" (353mm)  | 27 5/8" (702mm)  |
|                                | 4 1/4" (108mm) | 33" (838mm)     | 19 1/8" (486mm) | 38 1/8" (969mm)  |
| <b>36"</b><br>(914mm)          | 5 1/4" (133mm) | 33 1/2" (851mm) | 19 3/8" (492mm) | 38 5/8" (981mm)  |
|                                | 6 1/4" (159mm) | 33 7/8" (861mm) | 19 5/8" (499mm) | 39 1/8" (994mm)  |
|                                | 7 1/4" (184mm) | 34 3/8" (873mm) | 19 7/8" (505mm) | 39 5/8" (1007mm) |

EXAMPLE: 238-1260-12

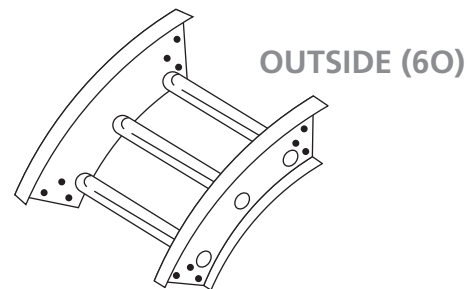
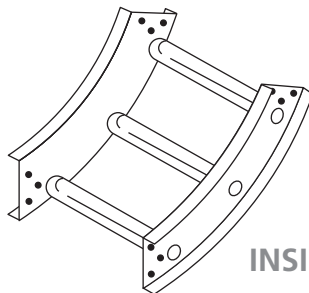

**Note:** Use Adjustable Connectors for odd angles. Nominal 9" rung spacing maintained through centerline of all fittings.

### Ordering Information:

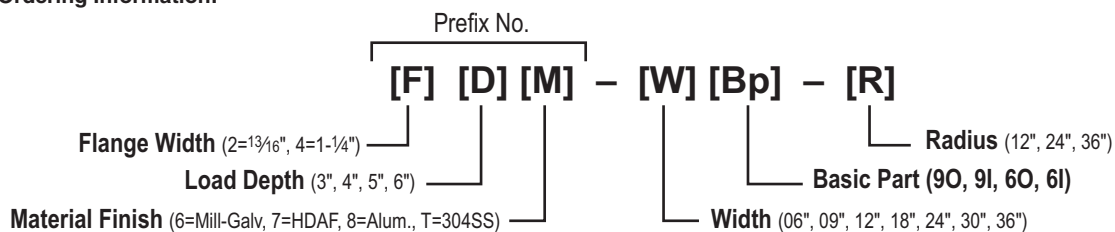

See Page 62 for Electrical Grounding Chart

## 45° Vertical Elbow Outside [40] & Inside [41]

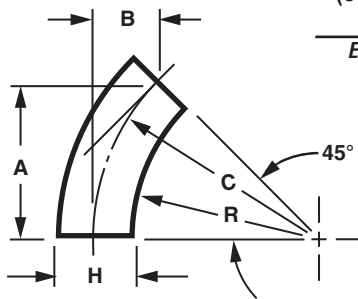
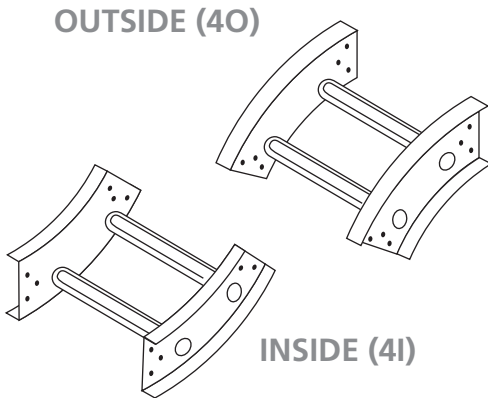

CSA Compliance for CSA Systems

| Radius - R            | "H" Dim.       | "A" Dim.        | "B" Dim.        | "C" Dim.         |
|-----------------------|----------------|-----------------|-----------------|------------------|
| <b>12"</b><br>(305mm) | 4 1/4" (108mm) | 10" (254mm)     | 4 1/8" (105mm)  | 14 1/8" (359mm)  |
|                       | 5 1/4" (133mm) | 10 3/8" (264mm) | 4 1/4" (108mm)  | 14 5/8" (372mm)  |
|                       | 6 1/4" (159mm) | 10 3/4" (273mm) | 4 1/2" (114mm)  | 15 1/8" (384mm)  |
|                       | 7 1/4" (184mm) | 11 1/8" (283mm) | 4 5/8" (118mm)  | 15 1/8" (397mm)  |
| <b>24"</b><br>(610mm) | 4 1/4" (108mm) | 18 1/2" (470mm) | 7 5/8" (194mm)  | 26 1/8" (664mm)  |
|                       | 5 1/4" (133mm) | 18 7/8" (480mm) | 7 7/8" (200mm)  | 26 5/8" (676mm)  |
|                       | 6 1/4" (159mm) | 19 1/4" (489mm) | 8" (203mm)      | 27 1/8" (689mm)  |
|                       | 7 1/4" (184mm) | 19 1/2" (495mm) | 8 7/8" (207mm)  | 27 5/8" (702mm)  |
| <b>36"</b><br>(914mm) | 4 1/4" (108mm) | 27" (686mm)     | 11 1/8" (283mm) | 38 1/8" (969mm)  |
|                       | 5 1/4" (133mm) | 27 3/8" (695mm) | 11 3/8" (289mm) | 38 5/8" (981mm)  |
|                       | 6 1/4" (159mm) | 27 5/8" (702mm) | 11 1/2" (292mm) | 39 1/8" (994mm)  |
|                       | 7 1/4" (184mm) | 8" (711mm)      | 11 5/8" (295mm) | 39 5/8" (1007mm) |

EXAMPLE: 238-1240-12

## 30° Vertical Elbow Outside [30] & Inside [31]

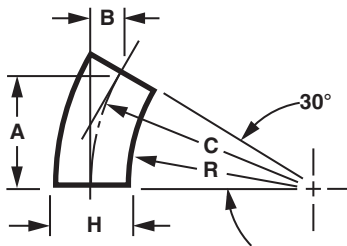
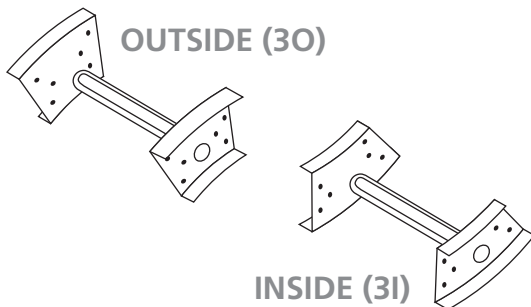

CSA Compliance for CSA Systems

| Radius - R            | "H" Dim.       | "A" Dim.        | "B" Dim.       | "C" Dim.         |
|-----------------------|----------------|-----------------|----------------|------------------|
| <b>12"</b><br>(305mm) | 4 1/4" (108mm) | 7 1/8" (181mm)  | 1 7/8" (48mm)  | 14 1/8" (359mm)  |
|                       | 5 1/4" (133mm) | 7 3/8" (187mm)  | 2" (51mm)      | 14 5/8" (372mm)  |
|                       | 6 1/4" (159mm) | 7 5/8" (194mm)  | 2" (51mm)      | 15 1/8" (384mm)  |
|                       | 7 1/4" (184mm) | 7 7/8" (200mm)  | 2 1/8" (54mm)  | 15 5/8" (397mm)  |
| <b>24"</b><br>(610mm) | 4 1/4" (108mm) | 13 1/8" (334mm) | 3 1/2" (89mm)  | 26 1/8" (664mm)  |
|                       | 5 1/4" (133mm) | 13 3/8" (340mm) | 3 5/8" (92mm)  | 26 5/8" (676mm)  |
|                       | 6 1/4" (159mm) | 13 5/8" (346mm) | 3 5/8" (92mm)  | 27 1/8" (689mm)  |
|                       | 7 1/4" (184mm) | 13 7/8" (353mm) | 3 3/4" (95mm)  | 27 5/8" (702mm)  |
| <b>36"</b><br>(914mm) | 4 1/4" (108mm) | 19 1/8" (486mm) | 5 1/8" (130mm) | 38 1/8" (969mm)  |
|                       | 5 1/4" (133mm) | 19 3/8" (492mm) | 5 1/4" (133mm) | 38 5/8" (981mm)  |
|                       | 6 1/4" (159mm) | 19 5/8" (499mm) | 5 1/4" (133mm) | 39 1/8" (994mm)  |
|                       | 7 1/4" (184mm) | 19 7/8" (505mm) | 5 3/8" (137mm) | 39 5/8" (1007mm) |

EXAMPLE: 238-1230-12

**Note:** Use Adjustable Connectors for odd angles. Nominal 9" rung spacing maintained through centerline of all fittings.

### Ordering Information:

See Page 62  
for Electrical  
Grounding Chart

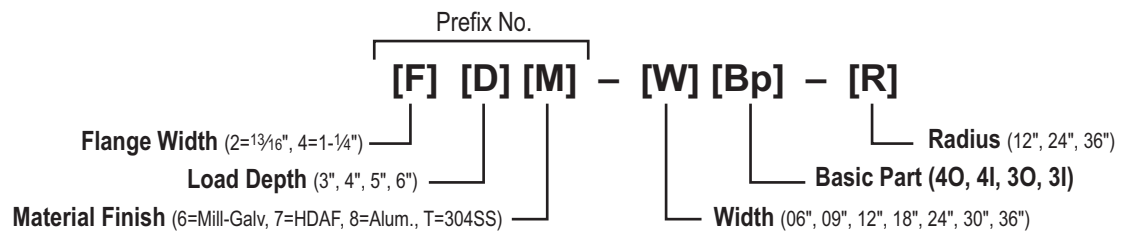

## 90° Vertical Cable Support Elbow [SR]

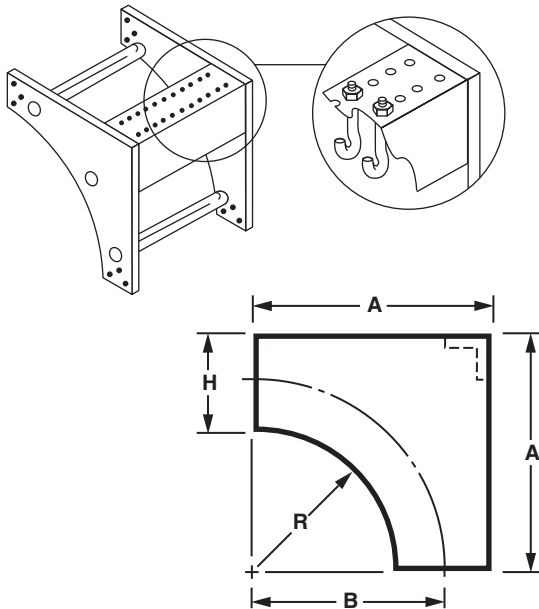

**CSA Compliance for CSA Systems**

| Radius - R            | "H" Dim.         | "A" Dim.         | "B" Dim.        |
|-----------------------|------------------|------------------|-----------------|
| <b>12"</b><br>(305mm) | 4 1/4" (108mm)   | 16 1/4" (413mm)  | 14 1/8" (359mm) |
|                       | 5 1/4" (133mm)   | 17 1/4" (438mm)  | 14 5/8" (371mm) |
|                       | 6 1/4" (159mm)   | 18 1/4" (464mm)  | 15 1/8" (384mm) |
| <b>24"</b><br>(610mm) | 4 1/4" (108mm)   | 28 1/4" (718mm)  | 26 1/8" (664mm) |
|                       | 5 1/4" (133mm)   | 29 1/4" (743mm)  | 26 5/8" (676mm) |
|                       | 6 1/4" (159mm)   | 30 1/4" (768mm)  | 27 1/8" (689mm) |
| <b>36"</b><br>(914mm) | 4 1/4" (108mm)   | 40 1/4" (1022mm) | 38 1/8" (968mm) |
|                       | 5 1/4" (133mm)   | 41 1/4" (1048mm) | 38 5/8" (981mm) |
|                       | 6 1/4" (159mm)   | 42 1/4" (1073mm) | 39 1/8" (994mm) |
| 7 1/4" (814mm)        | 43 1/4" (1099mm) | 39 5/8" (1006mm) |                 |

EXAMPLE: 238-12SR-12

## Vertical Tee Down [VT] & Up [OT]

### VERTICAL TEE - DOWN (VT)

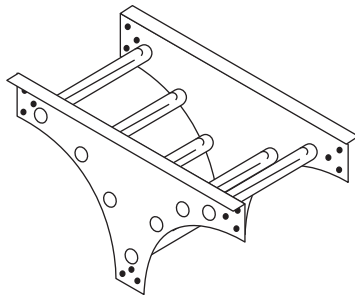

**CSA Compliance for CSA Systems**

| Radius - R            | "H" Dim.       | "A" Dim.         | "B" Dim.         | "C" Dim.         |
|-----------------------|----------------|------------------|------------------|------------------|
| <b>12"</b><br>(305mm) | 4 1/4" (108mm) | 28 1/4" (718mm)  | 16 1/4" (413mm)  | 14 1/8" (359mm)  |
|                       | 5 1/4" (133mm) | 29 1/4" (743mm)  | 17 1/4" (438mm)  | 14 5/8" (371mm)  |
|                       | 6 1/4" (159mm) | 30 1/4" (768mm)  | 18 1/4" (464mm)  | 15 1/8" (384mm)  |
|                       | 7 1/4" (814mm) | 31 1/4" (794mm)  | 19 1/4" (489mm)  | 15 5/8" (397mm)  |
| <b>24"</b><br>(610mm) | 4 1/4" (108mm) | 52 1/4" (1327mm) | 28 1/4" (718mm)  | 26 1/8" (664mm)  |
|                       | 5 1/4" (133mm) | 53 1/4" (1353mm) | 29 1/4" (743mm)  | 26 5/8" (676mm)  |
|                       | 6 1/4" (159mm) | 54 1/4" (1378mm) | 30 1/4" (768mm)  | 27 1/8" (689mm)  |
|                       | 7 1/4" (814mm) | 55 1/4" (1403mm) | 31 1/4" (794mm)  | 27 5/8" (702mm)  |
| <b>36"</b><br>(914mm) | 4 1/4" (108mm) | 76 1/4" (1937mm) | 40 1/4" (1022mm) | 38 1/8" (968mm)  |
|                       | 5 1/4" (133mm) | 77 1/4" (1962mm) | 41 1/4" (1048mm) | 38 5/8" (981mm)  |
|                       | 6 1/4" (159mm) | 78 1/4" (1988mm) | 42 1/4" (1073mm) | 39 1/8" (994mm)  |
|                       | 7 1/4" (814mm) | 79 1/4" (2013mm) | 43 1/4" (1099mm) | 39 5/8" (1006mm) |

EXAMPLE: 238-12VT-12

### VERTICAL TEE - UP (OT)

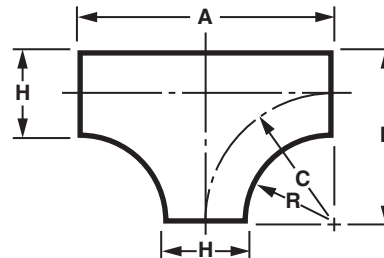
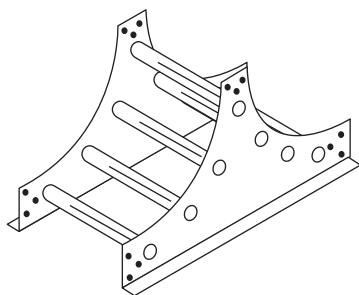

**Note:** Use Adjustable Connectors for odd angles. Nominal 9" rung spacing maintained through centerline of all fittings.

### Ordering Information:

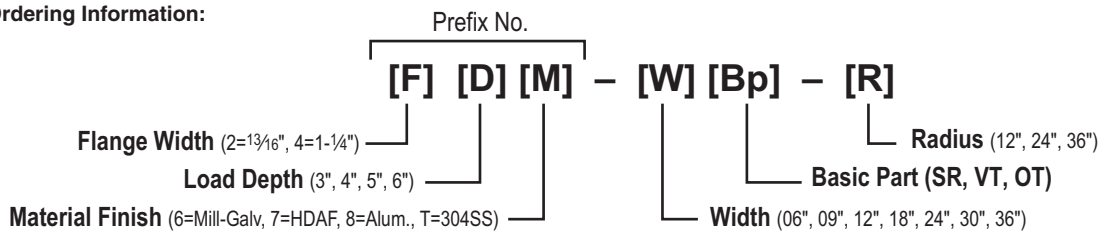

See Page 62  
for Electrical  
Grounding Chart

## CONNECTOR PLATES

### Tray Connectors

| Catalog Number |                |                |
|----------------|----------------|----------------|
| Load Depth     | Finish         | Basic No.      |
| 3"             | 6 (Mill Galv.) | -02RC          |
| 4"             | 7 (HDGAF)      | -02CE          |
| 5"             | 8 (Alum.)      | -02CV          |
| 6"             | T (304SS)      | -02CH<br>-02CA |

**EXAMPLE:** 38 -02RC for 3" load depth, aluminum, universal curvilinear connector.

**NOTE:** Hole patterns match corresponding tray.  
Three-hole pattern illustrated.

### Horizontal Adjustable Connector [CH]

**NOTE:** Sold in pairs – inner & outer

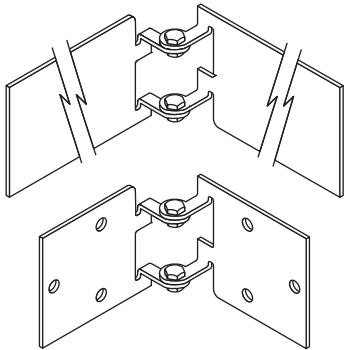

11 Gage Steel, 0.125" Aluminum  
3/8"-16 spline bolts & flange nuts furnished.

**NOTE:** Bonding Jumpers are required and are sold separately.

### Universal Curvilinear Connector [RC]

**NOTE:** Sold in pairs

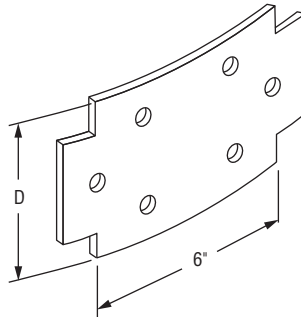

11 Gage Steel, 0.125" Aluminum  
3/8"-16 spline bolts & flange nuts furnished.

### Vertical Adjustable Connector [CV]

**NOTE:** Sold in pairs

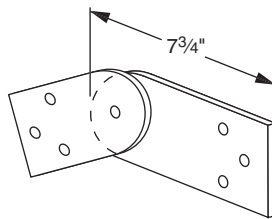

11 Gage Steel, 0.125" Aluminum  
3/8"-16 spline bolts & flange nuts furnished.

**NOTE:** Bonding Jumpers are required and are sold separately.

### Expansion Connector [CE]

**NOTE:** Sold in pairs

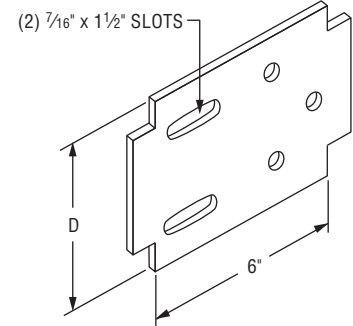

11 Gage Steel, 0.125" Aluminum  
3/8"-16 cap screws & Nylok nuts furnished and  
3/8"-16 spline bolts & flange nuts furnished.

**NOTE:** Bonding Jumpers are required and are sold separately.

### Mid-Span Splice Plate [RC]

Catalog Number: 58-02RC-MID

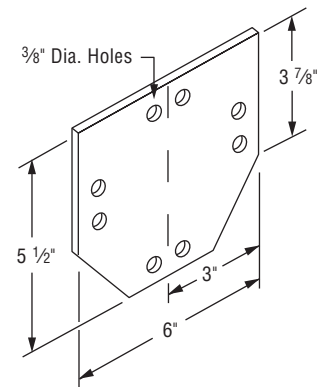

3/8" - Aluminum  
For use with 7D58 and 7G58 Systems.

### Reducing Connector [CO]

**NOTE:** Not sold in pairs

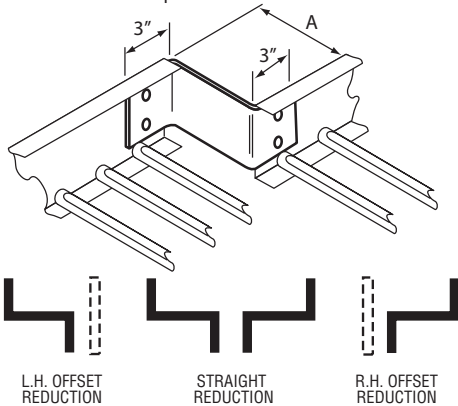

12 Gage Steel, 0.125" Aluminum

For offset reductions – use 1 of above with standard connector plate.

For straight reductions– use 2 (of 1/2 reduction dim.).  
3/8"-16 spline bolts and flange nuts furnished.

#### Catalog Number

| Load Depth | Finish         | Basic Number | "A" Dimension   |
|------------|----------------|--------------|-----------------|
| 3"         | 6 (Mill Galv.) | -30CO        | 30" (762mm)     |
| 4"         | 7 (HDGAF)      | -27CO        | 27" (686mm)     |
| 5"         | 8 (Alum.)      | -24CO        | 24" (610mm)     |
| 6"         | T (304SS)      | -21CO        | 21" (533mm)     |
|            |                | -18CO        | 18" (457mm)     |
|            |                | -15CO        | 15" (381mm)     |
|            |                | -13CO        | 13 1/2" (343mm) |
|            |                | -12CO        | 12" (305mm)     |
|            |                | -10CO        | 10 1/2" (267mm) |
|            |                | -09CO        | 9" (229mm)      |
|            |                | -07CO        | 7 1/2" (191mm)  |
|            |                | -06CO        | 6" (152mm)      |
|            |                | -04CO        | 4 1/2" (114mm)  |
| -03CO      | 3" (76mm)      |              |                 |
| -01CO      | 1 1/2" (38mm)  |              |                 |

**EXAMPLE:** 38-03CO for 3" load depth, aluminum, 3" Reducer Connector. Typical Use: 9" to 6", or use 2 for 12" to 6", etc.

### 90° Angle Connector [CA]

**NOTE:** Sold in pairs

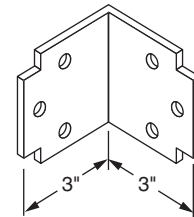

11 Gage Steel, 0.125" Aluminum  
3/8"-16 spline bolts and flange nuts furnished.

### MATERIAL/FINISH

Electrogalvanized finish standard. Other finishes available; consult factory.

\*Use following suffix when applicable - use only where indicated.

**EG**..... Electrogalvanized carbon steel only

**-SS**..... 302/304 Stainless Steel

**-SS316**.. 316 Stainless Steel (check factory for availability)

*Example:* E-142- 3/8 x 1 1/2 SS, 3/8 x 1 1/2 hex head bolt, 304 stainless steel

### Connector Hardware

(Case-hardened steel electrogalvanized)

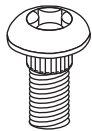

**Part No. 5003-1**  
3/8"-16 x 1" spline bolt



**Part No. 5009-1**  
3/8"-16 hex-flanged nut with serrated washer face.

### Cover Screw [E-150-S]

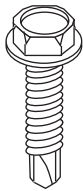

**E-150-S**  
Hex Head Lag Bolt



|                   |       |        |
|-------------------|-------|--------|
| <b>Screw Size</b> | 3/8"  | 1/2"   |
| <b>Drill Size</b> | 5/16" | 11/32" |

See Price Sheet for Length.

### Continuous Threaded Rod [H-104]

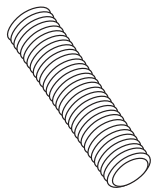

| Size | NATIONAL COARSE THREAD |              |                  |
|------|------------------------|--------------|------------------|
|      | Threads per inch       | lbs./100 ft. | Design Load lbs. |
| 1/4  | 20                     | 12.5         | 150              |
| 3/8  | 16                     | 29           | 610              |
| 1/2  | 13                     | 53.5         | 1130             |
| 5/8  | 11                     | 85           | 1810             |
| 3/4  | 10                     | 123          | 2710             |
| 7/8  | 9                      | 130          | 3770             |
| 1    | 8                      | 214          | 4960             |

### Rod Coupler [H-119]

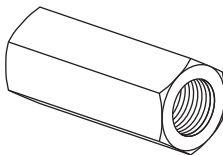

| Prod. #    | Rod Size | A     | Wt./C lbs. |
|------------|----------|-------|------------|
| H-119-1/4  | 1/4      | 1-3/4 | 9          |
| H-119-5/16 | 5/16     | 1-3/4 | 7          |
| H-119-3/8  | 3/8      | 1-3/4 | 10         |
| H-119-1/2  | 1/2      | 1-3/4 | 18         |
| H-119-5/8  | 5/8      | 2-1/8 | 23         |
| H-119-3/4  | 3/4      | 2-1/4 | 21         |
| H-119-7/8  | 7/8      | 2-1/2 | 55         |
| H-119-1    | 1        | 2-3/4 | 68         |

### Hex Nuts [E-145]



**E-145**  
Standard Hex Nut

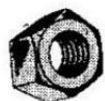

| Size | Wt./C lbs. |
|------|------------|
| 1/4  | .72        |
| 3/8  | 1.06       |
| 1/2  | 2.78       |
| 5/8  | 6.92       |
| 3/4  | 12.70      |
| 7/8  | 19.00      |
| 1    | 26.00      |

### Square Nuts [E-146]

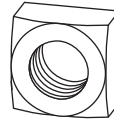

**E-146**  
Standard Square Nut



| Size | Wt./C lbs. |
|------|------------|
| 1/4  | .93        |
| 5/16 | 1.60       |
| 3/8  | 2.65       |
| 1/2  | 5.83       |
| 5/8  | 10.80      |

### Flat Washers [E-147]

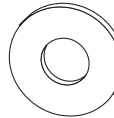

**E-147**  
Flat Steel Washer

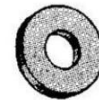

| Size | Wt./C lbs. |
|------|------------|
| 1/4  | .67        |
| 5/16 | 1.11       |
| 3/8  | 1.49       |
| 1/2  | 3.85       |
| 5/8  | 7.69       |
| 7/8  | 15.40      |

### Split-Lock Washers [E-148]

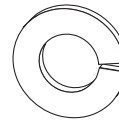

**E-148**  
Lock Washer



| Size | Wt./C lbs. |
|------|------------|
| 1/4  | .26        |
| 5/16 | .39        |
| 3/8  | .50        |
| 1/2  | 1.09       |
| 5/8  | 2.57       |

### Fender Washers [EF-147]

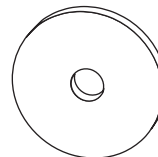

**EF-147**  
Fender Washer

| Size | A     | B    | Wt./C lbs. |
|------|-------|------|------------|
| 1/4  | 1-1/4 | 5/16 | 3.1        |
| 3/8  | 1-1/2 | 7/16 | 2.9        |
| 1/2  | 2     | 9/16 | 5.0        |

### Hex Head Cap Screw / Round Head, Slotted Cap Screw [E-142]

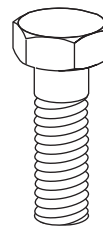

Catalog No. E-142

**E-142**  
Hex Head Cap Screw



| Size        | Wt./C lbs. |
|-------------|------------|
| 1/4 x 1     | 1.74       |
| 1/4 x 1-1/2 | 2.43       |
| 3/8 x 1     | 4.17       |
| 3/8 x 1-1/2 | 5.64       |
| 1/2 x 15/16 | 8.94       |
| 1/2 x 1-1/2 | 10.00      |

See Price Sheet For Additional Sizes

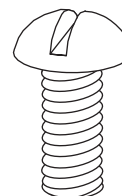

Catalog No. E-141

# LADDER CABLE TRAY SYSTEM



**COVERS** for straight sections shown. Standard fitting covers are flat solid type (NF). Aluminum covers are fabricated from 0.040" aluminum AA-3150-H14; steel covers are fabricated from 20 gage ASTM A-653-G90 CQ, mill-galvanized steel.

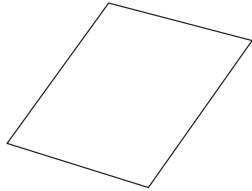

**NF** – Flat Solid

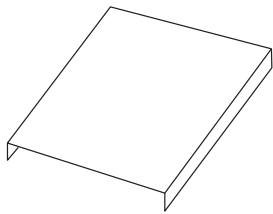

**FS** – Flat Solid  
w/  $\frac{3}{8}$ " Flange

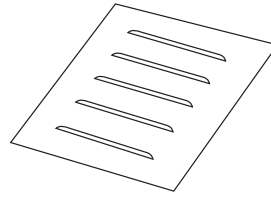

**NL** – Flat Louvered

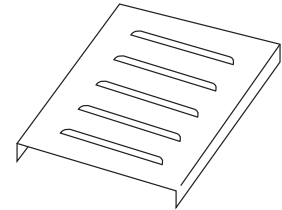

**FL** – Louvered  
w/  $\frac{3}{8}$ " Flange

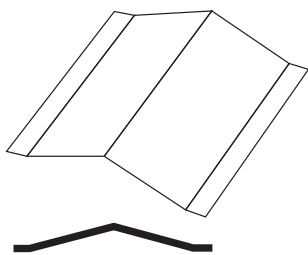

**PS** – Peaked Solid  
(suffix height)

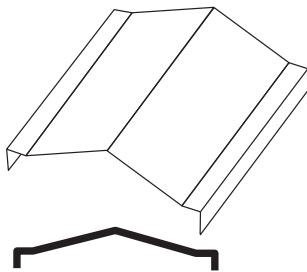

**PF** – Peaked Flanged Solid  
w/  $\frac{3}{8}$ " Flange  
(suffix height)

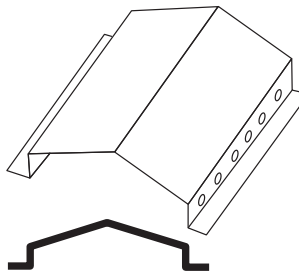

**PH** – Peaked Hat Solid  
**PV** – Peaked Hat Vent  
(suffix height)

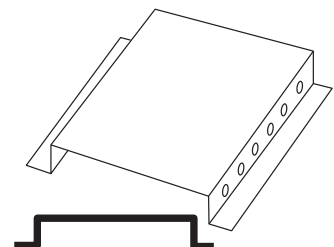

**HS** – Hat Solid  
**HV** – Hat Vent  
(suffix height)

## Cover Catalog Number – Straight Sections

| Type    | Flange                | Finish         | Basic No. (Width)   | Length | Height* |
|---------|-----------------------|----------------|---------------------|--------|---------|
| HS, HV, | 2 - $\frac{13}{16}$ " | 6 - Mill Galv. | -06SL = 6" (152mm)  | -06'   | -2"     |
| FL, FS, | 4 - $1\frac{1}{4}$ "  | 7 - HDGAF      | -09SL = 9" (229mm)  | -10'   |         |
| NF, NL, | 5 - $1\frac{1}{2}$ "  | 8 - Alum.      | -12SL = 12" (305mm) | -12'   |         |
| PS, PF, | 6 - $1\frac{3}{4}$ "  | T - 304SS      | -18SL = 18" (457mm) |        |         |
| PH, PV  | 7 - 2"                |                | -24SL = 24" (610mm) |        |         |
|         |                       |                | -30SL = 30" (762mm) |        |         |
|         |                       |                | -36SL = 36" (914mm) |        |         |

\*peak and hat only, 2" height standard. Consult factory for other heights.

**EXAMPLE:** NL46-09SL-10 is a flat louvered mill-galv. steel cover for a 9" wide mill galvanized ladder 10' long with a  $1\frac{1}{4}$ " flange.

## Cover Catalog Number – Fittings

| Type | Flange                | Load Depth | Finish         | Width/Basic No. | Radius |
|------|-----------------------|------------|----------------|-----------------|--------|
| NF   | 2 - $\frac{13}{16}$ " | 3          | 6 - Mill Galv. | -06 XX **       | 12"    |
| FS   | 4 - $1\frac{1}{4}$ "  | 4          | 7 - HDGAF      | -09 XX **       | 24"    |
|      |                       | 5          | 8 - Alum.*     | -12 XX **       | 36"    |
|      |                       | 6          | T - 304SS      | -18 XX **       |        |
|      |                       |            |                | -24 XX **       |        |
|      |                       |            |                | -30 XX **       |        |
|      |                       |            |                | -36 XX **       |        |

\* Load depth for outside riser or vertical tee only.

\*\* XX from fitting selection page 32

**EXAMPLE:** NF26-369F-24 is a mill galvanized non-flanged solid cover for a 36" wide horizontal 90° elbow with a 24" radius.

## Joint Plate

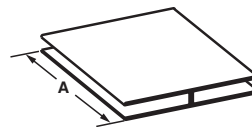

Joint plate is black PVC and is offered in 10' lengths to be field cut to desired length, or in pre-cut lengths for specified covers (e.g., PJ-06 is a joint plate for 6" wide tray).

| Part No. | Tray Size   |
|----------|-------------|
| JP-06    | 6" (152mm)  |
| JP-09    | 9" (229mm)  |
| JP-12    | 12" (305mm) |
| JP-18    | 18" (457mm) |

| Part No. | Tray Size         |
|----------|-------------------|
| JP-24    | 24" (610mm)       |
| JP-30    | 30" (762mm)       |
| JP-36    | 36" (914mm)       |
| JP-120   | 10' for field cut |

## Stainless Steel Cover Clip [CCS-SS]



$\frac{1}{4}$ " - 28 stainless steel cone point machine screw.  
Use with any width tray and cover. Not sold in pairs.

Indoor use only. Suggest spacing 6' max.

### Double Clamp Connector [(W) DC]

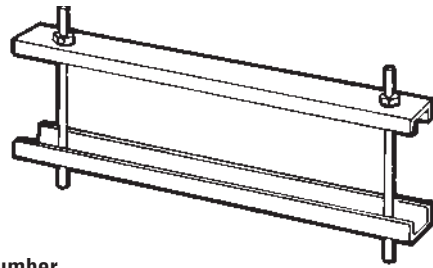

Catalog Number

| Flange                             | Load Depth | Finish       | Width | Type |
|------------------------------------|------------|--------------|-------|------|
| 2=1 <sup>3</sup> / <sub>16</sub> " | 3          | 6=Mill Galv. | -06   | DC   |
| 4=1 <sup>1</sup> / <sub>4</sub> "  | 4          | 7=HDGAF      | -09   |      |
| 5=1 <sup>1</sup> / <sub>2</sub> "  | 5          | 8=Alum.      | -12   |      |
| 6=1 <sup>3</sup> / <sub>4</sub> "  | 6          | T=304SS      | -18   |      |
| 7=2"                               |            |              | -24   |      |
|                                    |            |              | -30   |      |
|                                    |            |              | -36   |      |

*EXAMPLE:* 238-12DC for 3" load depth, 1<sup>3</sup>/<sub>16</sub>" flange, aluminum, Double Clamp Connector

For all covers except hat & peak type. Furnished with:  
(2) 1/4"-20 all-thread rods  
(4) hex nuts, flat washers and lock washers

Suggested spacing:  
Indoor: 2 per 12'  
Outdoor: 3 per 12'  
High Wind: 5 per 12'

### Peak Cover Connector [PC]

*Note:* For PS & PF Covers

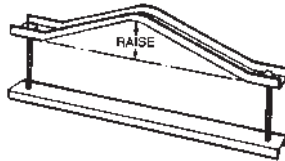

Catalog Number

| Flange                             | Load Depth | Finish       | Width | Type | Raise (in)* |
|------------------------------------|------------|--------------|-------|------|-------------|
| 2=1 <sup>3</sup> / <sub>16</sub> " | 3          | 6=Mill Galv. | -06   | PC   | -2          |
| 4=1 <sup>1</sup> / <sub>4</sub> "  | 4          | 7=HDGAF      | -09   |      |             |
| 5=1 <sup>1</sup> / <sub>2</sub> "  | 5          | 8=Alum.      | -12   |      |             |
| 6=1 <sup>3</sup> / <sub>4</sub> "  | 6          | T=304SS      | -18   |      |             |
| 7=2"                               |            |              | -24   |      |             |
|                                    |            |              | -30   |      |             |
|                                    |            |              | -36   |      |             |

\*2" standard raise. Consult factory for other peak heights.

*EXAMPLE:* 238-12PC-2 for 3" load depth, 1<sup>3</sup>/<sub>16</sub>" flange, aluminum, 12" wide, Peak Cover Connector with 2" peak.

### Peak Vent Cover Connector [VC]

*Note:* For PV Covers

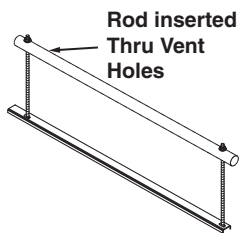

Catalog Number

| Flange                             | Load Depth | Finish       | Width | Type |
|------------------------------------|------------|--------------|-------|------|
| 2=1 <sup>3</sup> / <sub>16</sub> " | 3          | 6=Mill Galv. | -06   | VC   |
| 4=1 <sup>1</sup> / <sub>4</sub> "  | 4          | 7=HDGAF      | -09   |      |
| 5=1 <sup>1</sup> / <sub>2</sub> "  | 5          | 8=Alum.      | -12   |      |
| 6=1 <sup>3</sup> / <sub>4</sub> "  | 6          | T=304SS      | -18   |      |
| 7=2"                               |            |              | -24   |      |
|                                    |            |              | -30   |      |
|                                    |            |              | -36   |      |

*EXAMPLE:* 238-12VC for 3" load depth, 1<sup>3</sup>/<sub>16</sub>" flange, aluminum, 12" wide, Peak Vented Cover Connector

### Electro-Galv. Steel Cover Clip [PS 135X]

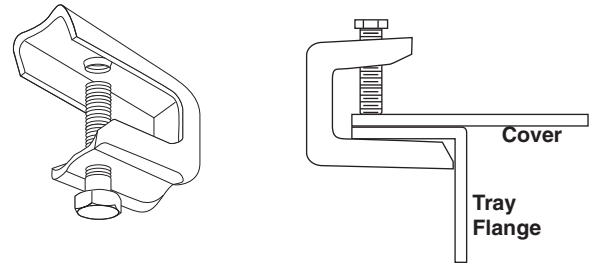

Use with any width tray. Not sold in pairs.  
Indoor use only. Suggest spacing 6' max.

### Cover Connector [CC]

*Note:* For all covers except hat & peak type

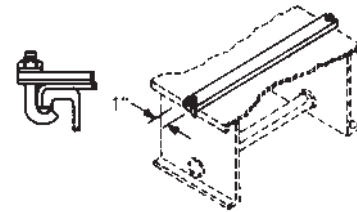

Catalog Number

| Flange                             | Finish       | Width | Type |
|------------------------------------|--------------|-------|------|
| 2=1 <sup>3</sup> / <sub>16</sub> " | 6=Mill Galv. | -06   | CC   |
| 4=1 <sup>1</sup> / <sub>4</sub> "  | 7=HDGAF      | -09   |      |
| 5=1 <sup>1</sup> / <sub>2</sub> "  | 8=Alum.      | -12   |      |
| 6=1 <sup>3</sup> / <sub>4</sub> "  | T=304SS      | -18   |      |
| 7=2"                               |              | -24   |      |
|                                    |              | -30   |      |
|                                    |              | -36   |      |

*EXAMPLE:* 28-12CC for aluminum, 12" wide Cover Connector

### Elevated Cover Connectors [EM-CC]

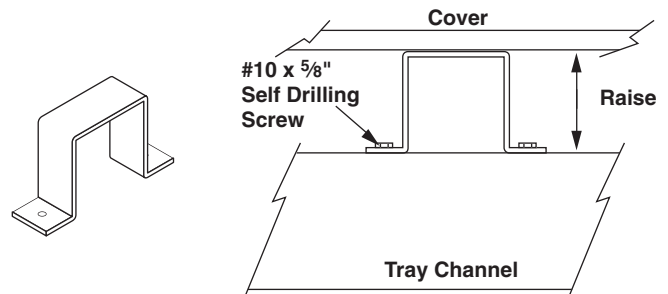

Catalog Number

| Finish       | Type  | Height*        |
|--------------|-------|----------------|
| 6=Mill Galv. | EM-CC | - Raise* (in.) |
| 7=HDGAF      |       |                |
| 8=Alum.      |       |                |
| T=304SS      |       |                |
|              |       |                |

\*1", 2" or 3" standard.

*EXAMPLE:* 7-EM-CC-2 for hot dipped galvanized, Elevated Cover Connector with a 2" raise

Includes:  
(3) #10 x 5/8 Self drilling screws.

Suggested spacing:  
Indoor: 3/Side  
(6 tot.) per 12';

# LADDER CABLE TRAY SYSTEM



## ACCESSORIES

### Box Connector [CB]

14 Gage Steel  
.080" Aluminum

**Note:** 1/4"-20 carriage bolts, flat washers, hex nuts furnished.

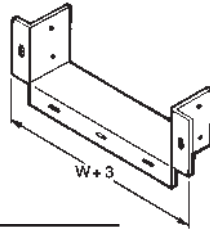

#### Catalog Number

| Load Depth | Finish         | Width               |
|------------|----------------|---------------------|
| 3          | 6 (Mill Galv.) | -06CB = 6" (152mm)  |
| 4          | 7 (HDGAF)      | -09CB = 9" (229mm)  |
| 5          | 8 (Alum.)      | -12CB = 12" (305mm) |
| 6          | T (304SS)      | -18CB = 18" (457mm) |
|            |                | -24CB = 24" (610mm) |
|            |                | -30CB = 30" (762mm) |
|            |                | -36CB = 36" (914mm) |

**EXAMPLE:** 38-12CB for 3" load depth, aluminum, 12" wide, Box Connector.

### Blind End [BE]

22 Gage Steel, .040" Aluminum

**Note:** 3/8"-16 spline bolts and flange nuts furnished.

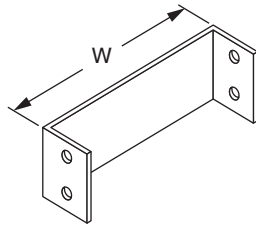

#### Catalog Number

| Load Depth | Finish         | Width               |
|------------|----------------|---------------------|
| 3          | 6 (Mill Galv.) | -06BE = 6" (152mm)  |
| 4          | 7 (HDGAF)      | -09BE = 9" (229mm)  |
| 5          | 8 (Alum.)      | -12BE = 12" (305mm) |
| 6          | T (304SS)      | -18BE = 18" (457mm) |
|            |                | -24BE = 24" (610mm) |
|            |                | -30BE = 30" (762mm) |
|            |                | -36BE = 36" (914mm) |

**EXAMPLE:** 38-12BE for 3" load depth, aluminum, 12" wide Blind End.

### Cable Tray Ground Clamp [9156]

Extruded Alum. with ElectroGalvanized Hex Head Screws  
Capacity: #6 AWG to 250 kcmil

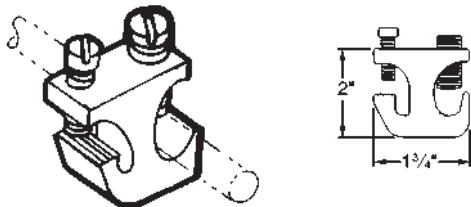

### Drop Out [DO]

14 Gage Steel  
.080" Aluminum

**Note:** (2) #10 x 5/8" self tapping screws furnished.

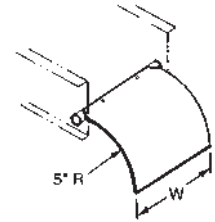

#### Catalog Number

| Basic Finish   | Width               |
|----------------|---------------------|
| 6 (Mill Galv.) | -06DO = 6" (152mm)  |
| 7 (HDGAF)      | -09DO = 9" (229mm)  |
| 8 (Alum.)      | -12DO = 12" (305mm) |
| T (304SS)      | -18DO = 18" (457mm) |
|                | -24DO = 24" (610mm) |
|                | -30DO = 30" (762mm) |
|                | -36DO = 36" (914mm) |

**EXAMPLE:** 8-12DO for aluminum, 12" wide, Drop Out.

### Bonding Jumper [CBJ]

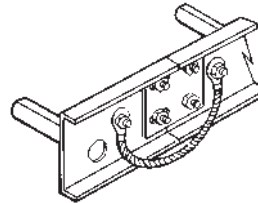

| Catalog No. | Dimensional Data                            | Amperes as Equipment Ground |
|-------------|---|-----------------------------|
| CBJ-C       | AWG 1/0 copper wire<br>15 1/2" long overall | 800 amperes                 |
| CBJ-4C      | AWG 4/0 copper wire<br>15 1/2" long overall | 1,600 amperes               |
| CBJ-250C    | 250 MCM copper wire<br>15 1/2" long overall | 2,000 amperes               |

#### NOTE:

No hardware supplied

For hardware kit add -HDW:

Ex: CBJ-C-HDW includes  
2ea CBJ-C  
4ea 5003-1  
4ea 5009-1

### Ground Cable Retainer Clamp

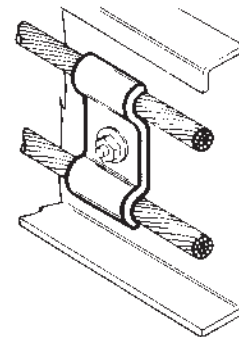

| Catalog No. | Capacity    | Metal & Finish      | Dimensions         |
|-------------|-------------|---------------------|--------------------|
| 9056-EP     | 1/0 2/0 3/0 | Electro-Galv. Steel | 1" w x 2" long     |
| 9057-EP     | 4/0 250 MCM |                     | 1" w x 2 3/8" long |
| 9056-SS     | 1/0 2/0 3/0 | Stainless Steel     | 1" w x 2" long     |
| 9057-SS     | 4/0 250 MCM |                     | 1" w x 2 3/8" long |

### Conduit Clamp Bracket

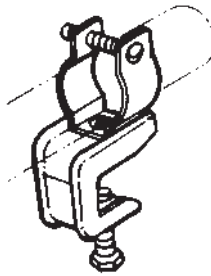

| Catalog No. | Size-Rigid   | Size-EMT |
|-------------|--------------|----------|
| CCB-050     | 3/8" to 1/2" | 1/2"     |
| CCB-075     | 3/4"         | 3/4"     |
| CCB-100     | 1"           | 1"       |
| CCB-125     | -            | 1 1/4"   |
| CCB-150     | 1 1/4"       | 1 1/2"   |
| CCB-200     | 2"           | 2"       |

### Conduit-to-Cable Tray Clamp Swivel Type

Malleable iron hub and steel "U" bolt. For connecting and grounding rigid conduit to tray at any angle within 90° arc. U.L. listed as a grounding means.

| Catalog No. | Size      | Std. Pkg. |
|-------------|-----------|-----------|
| TB6209      | 1/2"-3/4" | 10        |
| TB6211      | 1"-1 1/4" | 10        |
| TB6214      | 1 1/2"-2" | 5         |
| TB6216      | 2 1/2"-3" | 5         |
| TB6218      | 3 1/2"-4" | 2         |

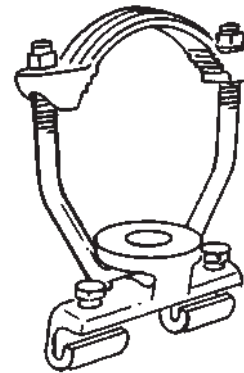

### Wall Penetrating Sleeve Assembly

Part No. SS89042(W)\*

W = Tray Width

\*=Fitting 3-Digit Prefix

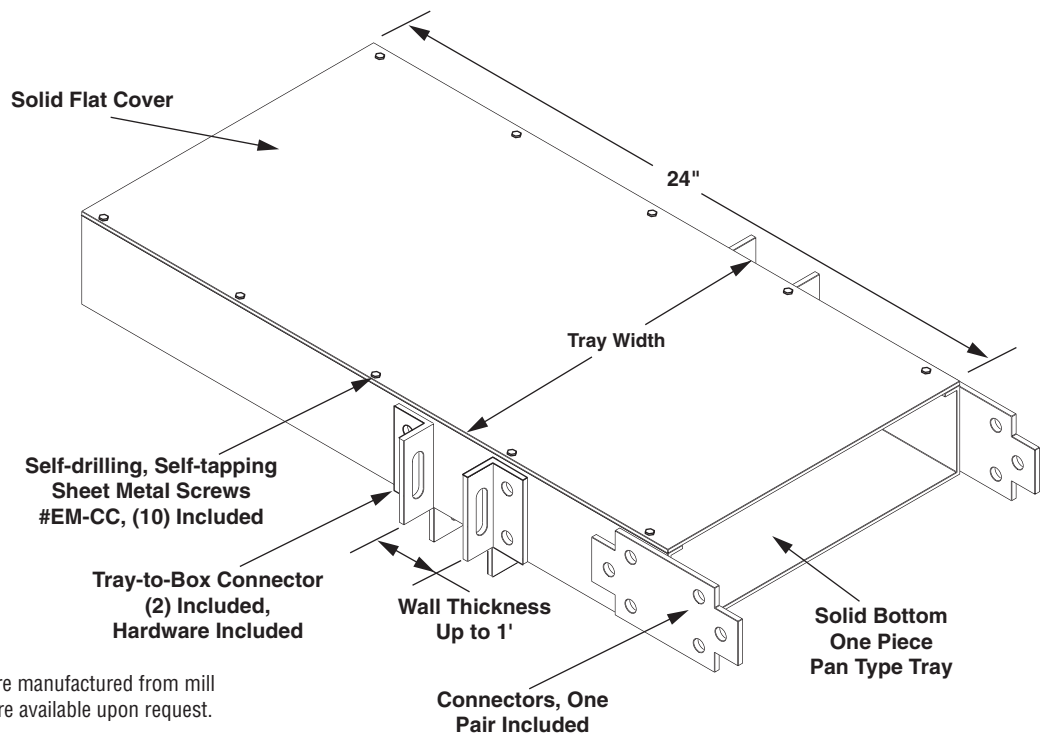

**Note:** Standard penetration sleeves are manufactured from mill galvanized steel. Aluminum sleeves are available upon request.

# LADDER CABLE TRAY SYSTEM



## BARRIER STRIPS

### Universal Aluminum Barrier Strip - Straight Section [SB]

| Catalog Number |           |                      |
|----------------|-----------|----------------------|
| Load Depth     | Finish    | Basic No. 12' Length |
| 3              | A (Alum.) | -01SB-12             |
| 4              |           |                      |
| 5              |           |                      |
| 6              |           |                      |

**EXAMPLE:** 3A-01SB-12 for 3" load depth, aluminum straight barrier, 12' long.

Furnished with 8 self tapping screws.

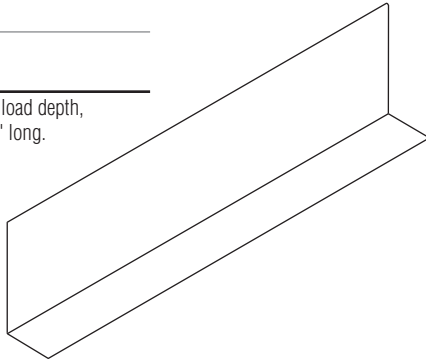

### Barrier Strip - Straight Section [SB]

| Catalog Number |                |                      |
|----------------|----------------|----------------------|
| Load Depth     | Finish         | Basic No. 12' Length |
| 3              | 6 (Mill Galv.) | -01SB-12             |
| 4              | 7 (HDGAF)      |                      |
| 5              | 8 (Alum.) *    |                      |
| 6              | T (304 SS)     |                      |

**EXAMPLE:** 46-01SB-12 for 4" load depth, mill galvanized straight barrier, 12' long.

Furnished with 4 barrier strip clamps and necessary hardware. (SB-HDW)

\* Long lead time item - See Universal aluminum barrier strip to the left

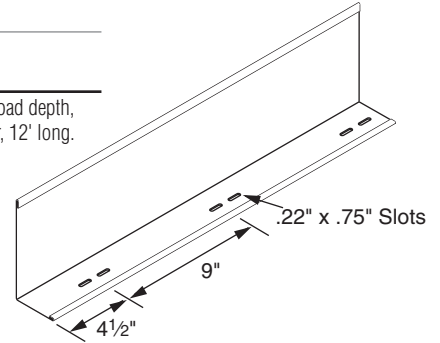

### Barrier Strip - Horizontal Fitting [FB]

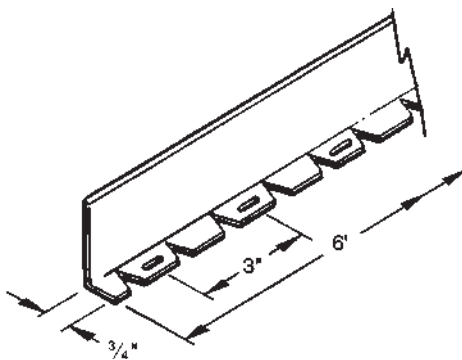

| Catalog Number |                |                     |
|----------------|----------------|---------------------|
| Load Depth     | Finish         | Basic No. 6' Length |
| 3              | 6 (Mill Galv.) | -01FB-06            |
| 4              | 7 (HDGAF)      |                     |
| 5              | 8 (Alum.)      |                     |
| 6              | T (304 SS)     |                     |

**EXAMPLE:** 38-01FB-06 for 3" load depth, aluminum fitting barrier, 6' long.

Furnished with 4 barrier strip clamps and necessary hardware.

### Barrier Strip Vertical Elbow Outside [OB] & Inside [IB] (OB shown)

Furnished with sufficient clamp assemblies for installation. Additional clamp assemblies may be ordered separately.

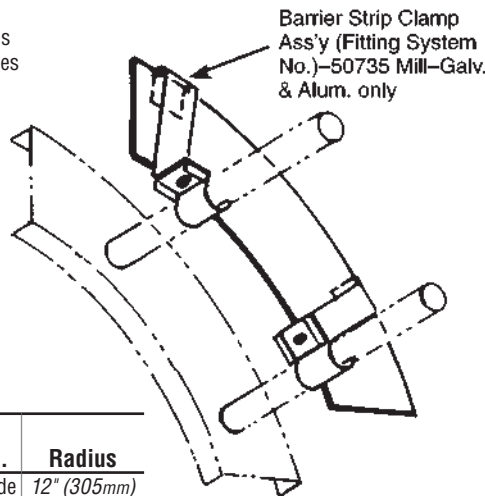

Barrier Strip Clamp Ass'y (Fitting System No.) - 50735 Mill-Galv. & Alum. only

| Catalog Number |                |             |              |             |
|----------------|----------------|-------------|--------------|-------------|
| Load Depth     | Finish         | Bend (deg.) | Basic No.    | Radius      |
| 3              | 6 (Mill Galv.) | 90          | OB = Outside | 12" (305mm) |
| 4              | 7 (HDGAF)      | 60          | IB = Inside  | 24" (610mm) |
| 5              | 8 (Alum.)      | 45          |              | 36" (914mm) |
| 6              | T (304 SS)     | 30          |              |             |

**EXAMPLE:** 38-90OB-12 for 3" load depth, aluminum 90° outside vertical barrier with 12" radius.

### Barrier Strip Clamp [SB-HDW]

Includes: (1) U-Bolt 707981505  
(2) Acorn Nuts 707671500

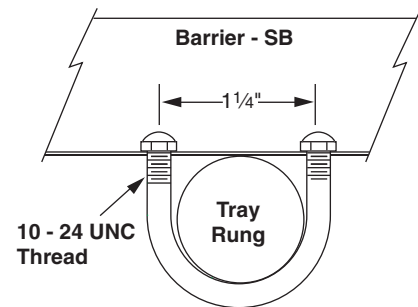

### Nylon Barrier Splice & Protector [BSP-L]

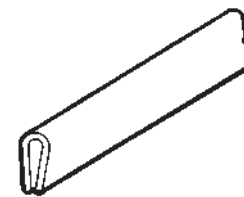

| Catalog Number |                       |
|----------------|-----------------------|
| Prefix         | Length (L)            |
| BSP            | -5 (5' Splice)        |
|                | -144 (144" Protector) |
|                | -1200 (100' Roll)     |

**EXAMPLE:** BSP-1200 for 100' roll

### Combination Hold-Down Clamp & Expansion Guide [9131]

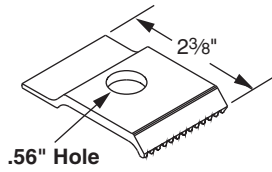

| Catalog No. | Material                 |
|-------------|--------------------------|
| 9131        | Cast Zinc                |
| 9131L       | 316 Type Stainless Steel |
| 9131A       | Aluminum                 |

Hardware purchased separately to suit support system.

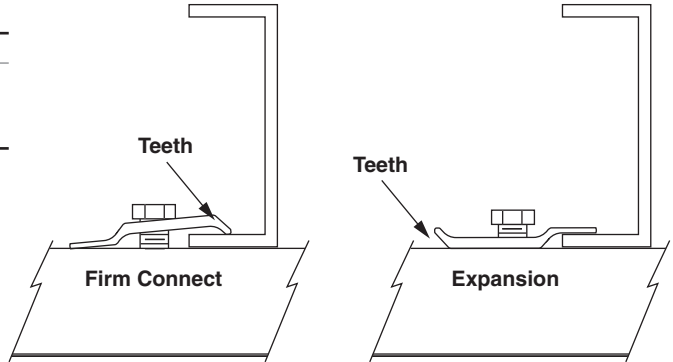

Catalog No. 9131-HDW (Complete Hardware Kit)  
 Hardware list:  
 (2) Combination hold-down clamp & expansion guide  
 (2) 1/2" - 13 x 1 1/4" Cap Screw  
 (2) 1/2" Flat Washer  
 (2) Clamping Nut (Strut Nut)

### Combination Hold-Down / Expansion Guide [9053]

Universal Guide: for either side of ladder. Use when tray is mounted on I-beams or channels. No drilling required.

**Note:** Use set screws for firm hold down

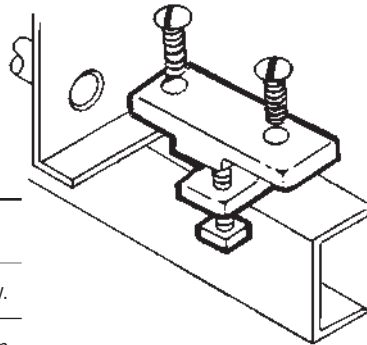

| Type              | Catalog No. | Finish      |
|-------------------|-------------|-------------|
| Combination Guide | 6-9053      | Elec. Galv. |
| Combination Guide | 8-9053      | Aluminum    |

**Note:** Electroplated set screws included

### Cover Screw

Part No. EM-CC (electro galv. steel)  
 Part No. EM-CC-SS (stainless steel)

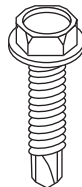

No. 10 x 5/8" long, self drilling-self tapping hex head plated steel screw.

Suggested spacing:

Indoor: 8 per 12';  
 Outdoor: 10 per 12'

### Isolation Pad [9131-IP]

The Isolation pad provides protection from galvanic corrosion when Aluminum tray is mounted on steel supports.

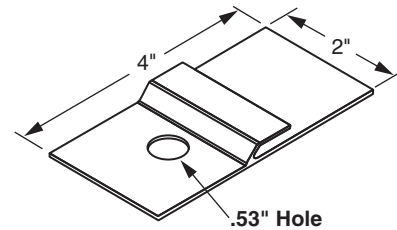

**Note:** For use with the 9131A shown above.

Hardware purchased separately

### Seismic Hold-Down [9132]

**Note:** Preferred for seismic applications or other bolted connections.

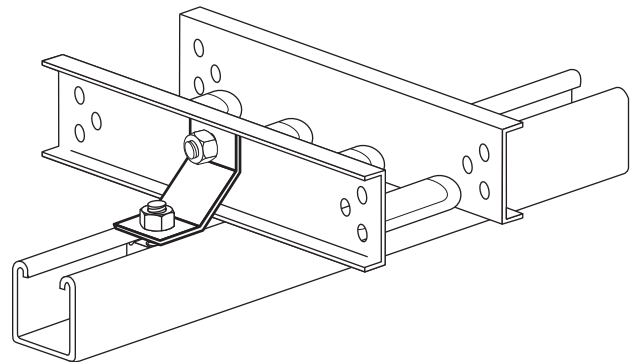

| Catalog No. | Material        |
|-------------|-----------------|
| 9132        | Mill Galvanized |
| 9133        | Stainless Steel |

Hardware purchased separately to suit support system.

## SUPPORTS

### Vertical Supports

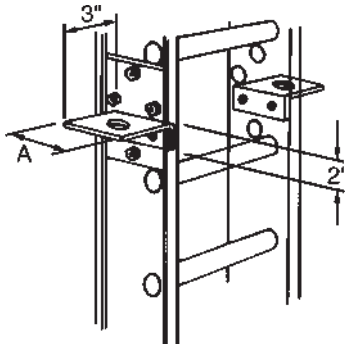

| Catalog No. | For Use With                                |
|-------------|---|
| 9043-37     | 4 1/4" Overall Height Side Members          |
| 9043        | 5 1/4" Overall Height Side Members          |
| 9025-98     | 6 1/4" & 7 1/4" Overall Height Side Members |

Ladder Supports can be bolted anywhere along the straight runs. They can be bolted directly onto the coupler plates at splices of straight runs and riser fittings, or they can be bolted at any place in the run by field-drilling side rails. Ladder supports are used with either 3/8" or 1/2" hanger rods. Finish is electrogalvanized.

### Gusset-Type Supports

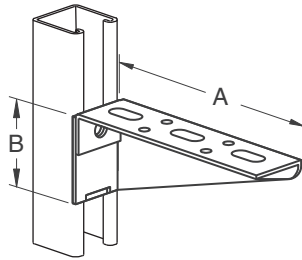

For use with all types of AB-Cope Ladder and Trof systems. Finish is electro-galvanized. Order hardware separately.

| Catalog No. | Ladder Width | Dimension |          | Uniform-Load Rating |
|-------------|--------------|-----------|----------|---------------------|
|             |              | A         | B        |                     |
| PS 838R-6   | -            | 6"        | 1 15/16" | 275 lbs.            |
| PS 838R-8   | -            | 8"        | 2 7/16"  | 275 lbs.            |
| PS 838R-10  | -            | 10"       | 2 15/16" | 275 lbs.            |
| PS 838R-12  | 6"           | 12"       | 3 7/16"  | 275 lbs.            |
| PS 838R-16  | 9"           | 16"       | 4 7/16"  | 275 lbs.            |
| PS 838R-18  | 12"          | 18"       | 4 15/16" | 275 lbs.            |
| PS 838R-24  | 18"          | 24"       | 6 7/16"  | 275 lbs.            |
| PS 838R-30  | 24"          | 30"       | 7 15/16" | 275 lbs.            |

### Channel-Type Supports

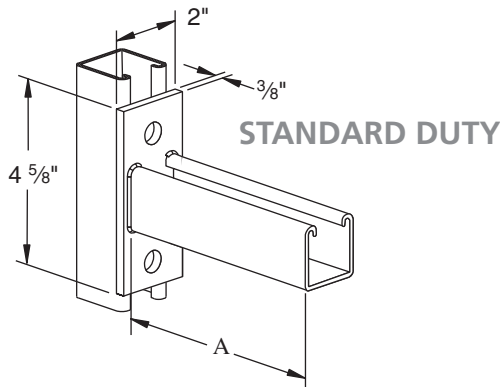

For use with all types of AB-Cope Ladder and Trof systems. Finish is electro-galvanized. Order hardware separately.

#### Standard Duty for Lighter Loads.

| Catalog No. | Ladder Width | Dimension A | Uniform-Load Rating* |
|-------------|--------------|-------------|----------------------|
| PS 651-6    | -            | 6"          | 1,200 lbs.           |
| PS 651-12   | 6"           | 12"         | 600 lbs.             |
| PS 651-15   | 9"           | 15"         | 480 lbs.             |
| PS 651-18   | 12"          | 18"         | 400 lbs.             |
| PS 651-24   | 18"          | 24"         | 300 lbs.             |
| PS 651-30   | 24"          | 30"         | 240 lbs.             |
| PS 651-36   | 30"          | 36"         | -                    |

\* Mounted on 12 Ga. Channel.

### Double Channel-Type Supports

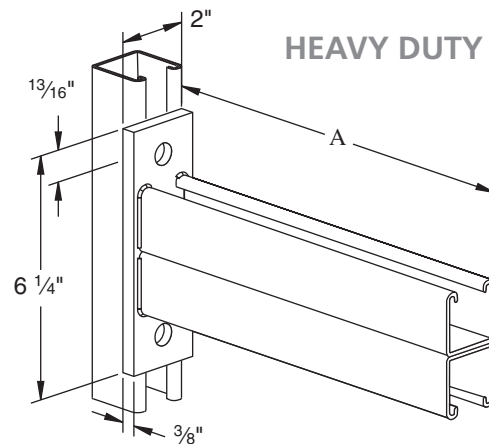

For use with all types of AB-Cope Ladder and Trof systems. Finish is electro-galvanized. Order hardware separately.

#### Heavy Duty for Heavier Loads

| Catalog No. | Ladder Width | Dimension A | Uniform-Load Rating* |
|-------------|--------------|-------------|----------------------|
| PS 809-12   | 6"           | 12"         | 2,000 lbs.           |
| PS 809-15   | 9"           | 15"         | 1,600 lbs.           |
| PS 809-18   | 12"          | 18"         | 1,330 lbs.           |
| PS 809-24   | 18"          | 24"         | 1,000 lbs.           |
| PS 809-30   | 24"          | 30"         | 800 lbs.             |
| PS 809-36   | 30"          | 36"         | 660 lbs.             |
| PS 809-42   | 36"          | 42"         | 570 lbs.             |

\* Mounted on 12 Ga. Channel.

## SUPPORT BRACKETS & TRAY HANGERS

AB-COPE LADDER

### Wall Support Brackets

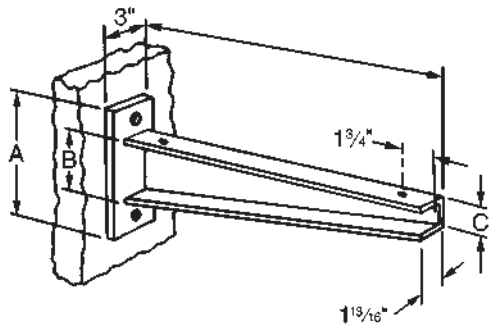

| Catalog Number | Ladder Width | Length "L" | Dimensions |     |        | End-Load Rating* |
|----------------|--------------|------------|------------|-----|--------|------------------|
|                |              |            | "A"        | "B" | "C"    |                  |
| 9037-12        | 6"           | 12 1/4"    | 10"        | 6"  | 2"     | 2000 lbs.        |
| 9037-18        | 12"          | 18 1/4"    | 11"        | 7"  | 2 1/2" | 2000 lbs.        |
| 9037-24        | 18"          | 24 1/4"    | 11"        | 7"  | 2 1/2" | 1600 lbs.        |
| 9037-30        | 24"          | 30 1/4"    | 12"        | 8"  | 4"     | 1300 lbs.        |
| 9037-36        | 30"          | 36 1/4"    | 12"        | 8"  | 4"     | 1100 lbs.        |
| 9037-42        | 36"          | 42 1/4"    | 12"        | 8"  | 4"     | 900 lbs.         |

\*Uniform load rating is normally twice the end-load rating.  
Finish is hot-dip galvanized after fabrication.  
Order hardware separately

### Tray Hanger

Part No. 7-HGR1 (Steel),  
Part No. 8-HGR1 (Aluminum)  
(Sold Individually)

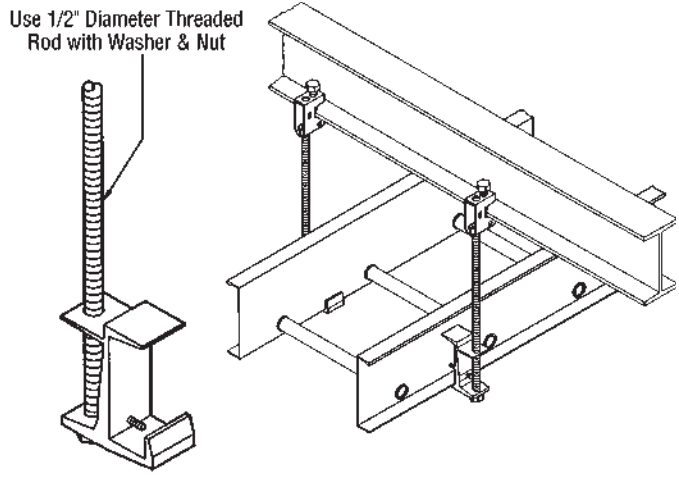

### Structural Support Bracket

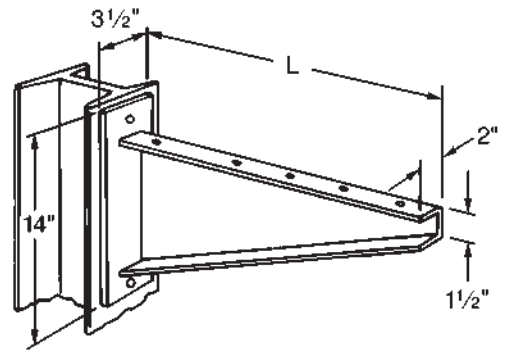

| Catalog No. | Ladder Width | Length "L" | End-Load Rating* |
|-------------|--------------|------------|------------------|
| 9036-31     | 24"          | 31 1/4"    | 2000 lbs.        |
| 9036-37     | 30"          | 37 1/4"    | 1800 lbs.        |
| 9036-45     | 36"          | 45 1/4"    | 1500 lbs.        |

\*Uniform load rating is normally twice the end-load rating.  
For use with AB-Cope Ladder 24" or wider. May be welded or bolted to building steel.  
Finish is hot-dip galvanized after fabrication.  
Order hardware separately.

### Single Ladder Hangers

AB-Cope Ladder Hangers are sized according to the side rail height and flange dimensions of various AB-Cope ladders. The 1 7/32" holes accommodate either 3/8" or 1/2" diameter threaded rod.

Order hardware separately.  
Finish is Mill-Galv., HDGAF, or Aluminum.

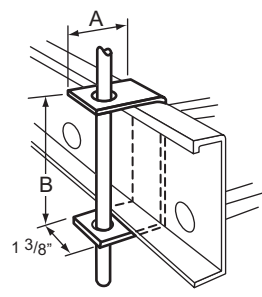

| Basic No. | Catalog No. |               |       | Side Rail      | "A" Dim. | "B" Dim. |
|-----------|-------------|---------------|-------|----------------|----------|----------|
|           | M.G.        | Finish H.D.G. | Alum. |                |          |          |
| 9038-     | 236         | 237           | 238   | 4 1/4 x 1 3/16 | 2"       | 4 5/16"  |
| 9038-     | 246         | 247           | 248   | 5 1/4 x 1 3/16 | 2"       | 5 5/16"  |
| 9038-     | 256         | 257           | 258   | 6 1/4 x 1 3/16 | 2"       | 6 5/16"  |
| 9038-     | 266         | 267           | 268   | 7 1/4 x 1 3/16 | 2"       | 7 5/16"  |
| 9038-     | 436         | 437           | 438   | 4 1/4 x 1 1/4  | 2 9/16"  | 4 5/16"  |
| 9038-     | 446         | 447           | 448   | 5 1/4 x 1 1/4  | 2 9/16"  | 5 5/16"  |
| 9038-     | 456         | 457           | 458   | 6 1/4 x 1 1/4  | 2 9/16"  | 6 5/16"  |
| 9038-     | 466         | 467           | 468   | 7 1/4 x 1 1/4  | 2 9/16"  | 7 5/16"  |

# LADDER CABLE TRAY SYSTEM



## TRAY HANGER & SUPPORTS

### Single Rod Hanger Support

| Catalog Number |                 |                         |                        |                       |                |
|----------------|-----------------|-------------------------|------------------------|-----------------------|----------------|
| Assy. Type     | Channel Length* | Channel Finish**        | Rod Diameter           | Rod Length            | Beam Clamp     |
| P200           | 14"<br>(356mm)  | GV<br>(Pre-Galv)        | 38=3/8"<br>(9.53mm)    | 000 -<br>No Rod       | A - Bridgeport |
|                | 17"<br>(432mm)  |                         | 12=1/2"<br>(12.7mm)    | 036 - 36"<br>(914mm)  | B - P2622      |
|                | 20"<br>(508mm)  | HG<br>(Hot Dipped Galv) |                        | 072 - 72"<br>(1828mm) | O - No Clamp   |
|                | 26"<br>(661mm)  |                         | 120 - 120"<br>(3048mm) | R - Rod Coupler       |                |
|                | 32"<br>(813mm)  |                         | 144 - 144"<br>(3658mm) | S - Special           |                |
|                | 38"<br>(966mm)  |                         |                        |                       |                |
|                | 44"<br>(1118mm) |                         |                        |                       |                |

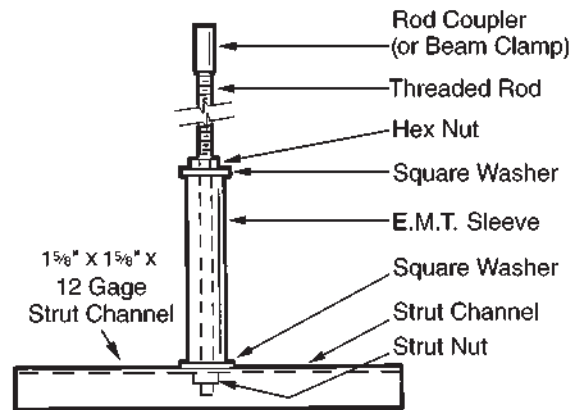

**EXAMPLE:**

P20020GV12036B is a Single 20" pre-galvanized channel with 1/2" x 36" drop rod and P2622 clamp.

**NOTE:**

\*Order channel length 8" longer than tray width.

For example, 44" channel for 36" tray.

\*\* Other channel types and finishes available upon request. Contact factory.

To order hardware only:

3/8" - PGV380000

1/2" - PGV120000

### Trapeze Hanger Support

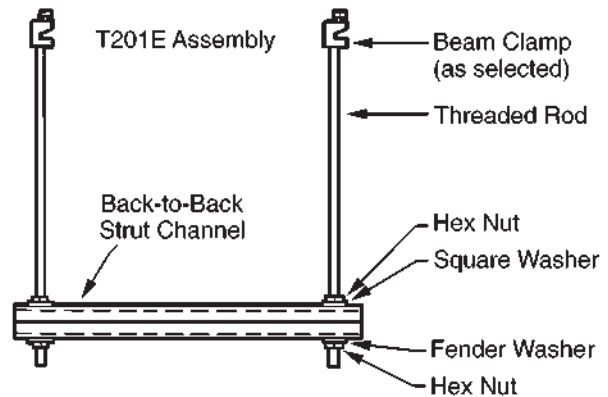
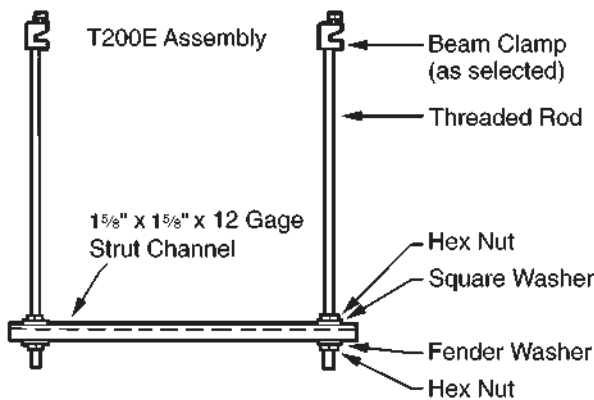

| Catalog Number |                 |                      |                     |                        |                 |
|----------------|-----------------|----------------------|---------------------|------------------------|-----------------|
| Assy. Type     | Channel Length* | Channel Finish**     | Rod Diameter        | Rod Length             | Beam Clamp      |
| T200E          | 16"<br>(407mm)  | GV (Pre-Galv)        | 38=3/8"<br>(9.53mm) | 000 -<br>No Rod        | A - PS 85       |
| T201E          | 19"<br>(483mm)  | HG (Hot Dipped Galv) | 12=1/2"<br>(12.7mm) | 036 - 36"<br>(914mm)   | B - P2622       |
|                | 22"<br>(559mm)  |                      |                     | 072 - 72"<br>(1828mm)  | O - No Clamp    |
|                | 28"<br>(712mm)  |                      |                     | 120 - 120"<br>(3048mm) | R - Rod Coupler |
|                | 34"<br>(864mm)  |                      |                     | 144 - 144"<br>(3658mm) | S - Special     |
|                | 40"<br>(1017mm) |                      |                     |                        |                 |
|                | 46"<br>(1169mm) |                      |                     |                        |                 |

**EXAMPLE:** T200E22GV12036B is a Single 22" pre-galvanized channel with 1/2" x 36" drop rod and P2622 clamp.

**NOTE:** \*Order channel length 10" longer than tray width. For example, 46" channel for 36" tray.

\*\* Other channel types and finishes available upon request. Contact factory.

To order hardware only:

3/8" - PGV380000

1/2" - PGV120000

## Electrical Grounding Chart

Table 1 below provides the Minimum Cross Sectional area for two side rails. Using the Fitting Prefix Number (248), the proper value is determined by the Material (column 3), the Flange Width (column 1), and Load Depth (column 2). Locate the line containing the Load Depth (column 1) and follow it to the right to the appropriate Flange Width and Material.

**TABLE 1**

| Fitting Prefix Number               |            |              | Min. X-Sect for 2 Rails (NEC® Table 392.7B) |                                      |  |                                      |
|-------------------------------------|------------|--------------|---|--------------------------------------|--|--------------------------------------|
|                                     |            |              | Aluminum                                    |                                      | Steel                                  |                                      |
|                                     |            |              | <sup>13</sup> / <sub>16</sub> " Flange      | <sup>1</sup> / <sub>4</sub> " Flange | <sup>13</sup> / <sub>16</sub> " Flange | <sup>1</sup> / <sub>4</sub> " Flange |
| Flange                              | Load Depth | Material     | X-Sect Area                                 | X-Sect Area                          | X-Sect Area                            | X-Sect Area                          |
| 2 - <sup>13</sup> / <sub>16</sub> " | 3"         | 6 - Mill Gal | 0.60  | 0.60                                 | 0.40                                   | 0.70                                 |
| 4 - <sup>1</sup> / <sub>4</sub> "   | 4"         | 7 - HDGAF    | 0.60  | 0.60                                 | 0.40                                   | 0.70                                 |
|                                     | 5"         | 8 - Alum.    | 0.60  | 1.00                                 | 0.70                                   | 0.70                                 |
|                                     | 6"         |              | 0.60  | 1.00                                 | 0.70                                   | 1.00                                 |

Find that value in Table 2, follow it to the right to the Material column to determine the Maximum Ground Fault Amperage.

**TABLE 2**

| Maximum Ground Fault Amperage (in Amps) |          |       |
|---|----------|-------|
| X-Sect Area                             | Material |       |
|   | Aluminum | Steel |
| .40 sq in                               | -        | 100   |
| .60 sq in                               | 1000     | -     |
| .70 sq in                               | -        | 200   |
| 1.00 sq in                              | 1200     | 400   |

**For Example:**

If the fitting prefix is 248, the Flange is <sup>13</sup>/<sub>16</sub>", the Load Depth is 4", and the Material is Aluminum. The Minimum Cross Sectional Area (X-Sect Area) is 0.60 sq. in. The Amperage is 1000.

## Typical Specifications

By specifying the NEMA class designation, you will use the simplest, clearest, and most complete method of specification available and automatically incorporate support span in feet, working (allowable) load in pounds per linear foot, a safety factor of 1.5, a concentrated load, if present; and, all other design, manufacturing, and test standards including electrical continuity.

All you need to do is add the desired load depth, rung spacing, radius of fittings, metal, and finish. You may add accessory information pursuant to your project. Here is a typical specification for an outdoor tray system where the working (allowable) load has been determined to be approximately 75 pounds per foot on support spans of 12'-0".

## SPECIFICATION ALUMINUM AB-COPE LADDER SYSTEM

Cable Ladder shall be manufactured by a company regularly engaged in the manufacture of metal cable trays and shall be a member of NEMA. Trays shall conform to NEMA Metal Cable Tray Standard Publication VE-1 (latest issue).

- Cable ladder shall be NEMA Classification 12B of the widths indicated.
- Material shall be aluminum alloy with side rails and rungs of 6063.
- Finish shall be natural.
- Inside load depth to be NEMA Standard 3".
- Fittings shall be 12" radius for control cables and 24" radius for power cables. (This must be commensurate with the cable manufacturer's recommended minimum bending radius.)
- All top level trays in stacks and single runs to have raised, peaked aluminum ventilated covers with heavy duty hold down clamps every 3'-0".
- Install expansion connectors, expansion guides, and hold down clamps per NEMA Standard VE-1.
- Where slopes or horizontal bends of trays are not at the Standard NEMA angles, use adjustable connectors. If the angle is too great for cable bending radius, use combinations of fitting and adjustable connectors.
- Separate all cables of different volt ages in the same tray using the manufacturer's standard barriers and barrier hold down system.
- The Cable Ladder system will be used as an equipment grounding conductor.
- To save space fittings shall have no tangents. To facilitate field installation, use one pair of universal type connector plates for rigid joints.
- Cable Ladder shall have outward facing side rails with tubular rungs assembled into side rails by cold swaging. Cable support surface on top of rungs to be flattened. Inside of tray shall not have flanges or other projections. Full access to the contents of the Cable Ladder shall be available.
- Trays shall be AB-Cope Cable Ladder System Number 3B38 as manufactured by AB-Cope standard design.

# LADDER CABLE TRAY SYSTEM



## FITTINGS

| Aluminum      |                | Mill Galv.    |                | HDGAF         |                |
|---------------|----------------|---------------|----------------|---------------|----------------|
| SYSTEM NUMBER | FITTING PREFIX | SYSTEM NUMBER | FITTING PREFIX | SYSTEM NUMBER | FITTING PREFIX |
| 1B38.....     | 238            | 8236.....     | 236            | 6257.....     | 257            |
| 1B48.....     | 248            | 8246.....     | 246            | 6D37.....     | 437            |
| 3B58.....     | 258            | 8256.....     | 256            | 4D37.....     | 437            |
| 1B68.....     | 268            | 8266.....     | 266            | 6447.....     | 447            |
| 3B38.....     | 238            | 8B36.....     | 236            | 6457.....     | 457            |
| 5B38.....     | 238            | 8B66.....     | 266            | 6467.....     | 467            |
| 3B48.....     | 248            | 8B46.....     | 246            | 4D47.....     | 447            |
| 5B58.....     | 258            | 6256.....     | 256            | 6D57.....     | 457            |
| 5B68.....     | 268            | 8D36.....     | 436            | 6D67.....     | 467            |
| 7448.....     | 448            | 8D46.....     | 446            | 4D57.....     | 457            |
| 1D58.....     | 458            | 8D56.....     | 456            | 4467.....     | 467            |
| 1E68.....     | 468            | 8466.....     | 466            | 4B37.....     | 237            |
| 3D38.....     | 438            | 6D36.....     | 436            | 6B47.....     | 247            |
| 5D38.....     | 438            | 4D36.....     | 436            | 4B47.....     | 247            |
| 3D48.....     | 448            | 6446.....     | 446            | 2D37.....     | 437            |
| 3658.....     | 458            | 6456.....     | 456            | 2D47.....     | 447            |
| 5E38.....     | 438            | 8D66.....     | 466            | 2D57.....     | 457            |
| 5D48.....     | 448            | 6466.....     | 466            | 11D57.....    | 457            |
| 7D58.....     | 458            | 4D46.....     | 446            |               |                |
| 9D58.....     | 458            | 6D56.....     | 456            |               |                |
| 7G58.....     | 458            | 6D66.....     | 466            |               |                |
| 7G58.....     | 758*           | 4D56.....     | 456            |               |                |
| 5D58.....     | 458            | 4466.....     | 466            |               |                |
| 5D68.....     | 468            | 4B36.....     | 236            |               |                |
|               |                | 6B46.....     | 246            |               |                |
|               |                | 4B46.....     | 246            |               |                |
|               |                | 2D36.....     | 436            |               |                |
|               |                | 2D46.....     | 446            |               |                |
|               |                | 2D56.....     | 456            |               |                |
|               |                | 11D56.....    | 456            |               |                |

\* Alternate Fitting



# AB-COPE I-BEAM

# 4



## PICTORIAL INDEX

### General & Technical Information

|  |         |
|--|---------|
| Pictorial Index.....                                     | 66      |
| Selection Chart, Straight Length, Load information ..... | 67 - 68 |
| Straight Length & Ordering Information .....             | 69      |
| Suggested Fittings .....                                 | 70      |

### AB-Cope Ladder Fittings

|                                       |    |
|---------------------------------------|----|
| Horizontal Elbows                     |    |
| 90° .....                             | 71 |
| 60° .....                             | 72 |
| 45° .....                             | 73 |
| 30° .....                             | 74 |
| Horizontal Tee .....                  | 75 |
| Horizontal Tapped Tee.....            | 76 |
| Horizontal Cross .....                | 77 |
| Horizontal Tapped Cross .....         | 78 |
| Straight Reducers.....                | 79 |
| Left and Right Hand Reducers .....    | 79 |
| 45°"Y" Branch.....                    | 80 |
| Vertical Elbows (Inside and Outside)  |    |
| 90° .....                             | 81 |
| 60° .....                             | 82 |
| 45° .....                             | 83 |
| 30° .....                             | 84 |
| 90° Vertical Cable Support Elbow..... | 85 |
| Vertical Tee .....                    | 85 |

### Connectors & Hardware

|   |    |
|---|----|
| Horizontal Adjustable Connector, Expansion Connector, Universal Connector,<br>Reducing Connector, Mid-Span Splice Plate ..... | 86 |
| Vertical Hanger Splice Plate,<br>Hold Down Brackets, Adjustable Vertical Connectors.....                                      | 87 |
| Hold Down Clamp and Expansion Guide,<br>Cable Clamp, Isolation Pad, Box Splice Plates .....                                   | 88 |
| General Hardware, Threaded Rod .....  | 89 |

### Covers

|   |    |
|---|----|
| Covers, Joint Plate.....  | 90 |
| Cover Attachments (Hold Down Clamps,<br>Elevated and Peaked Cover Connectors, Steel Cover Clip) ..... | 91 |

### Accessories

|  |         |
|--|---------|
| Blind End, Drop Out, Bonding Jumper, Box Connector<br>Cable Tray Ground Clamp, Ground Cable Retainer Clamp ..... | 92      |
| Conduit & Pipe Clamps, Wall Sleeve Assembly .....  | 93      |
| Barrier Strips and Barrier Strip Clamps.....   | 94      |
| Support Brackets.....  | 95 - 96 |
| Tray Brackets, Rooftop Support System .....  | 96      |
| Hanger Support, Trapeze Hanger Support .....   | 97      |

### Specification Information

|                                  |    |
|----------------------------------|----|
| Electrical Grounding Chart ..... | 98 |
| Typical Specification .....      | 98 |

## Straight Length

Pages 67 - 69

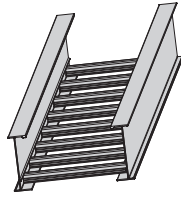

## Horizontal Elbows

Pages 71 - 74

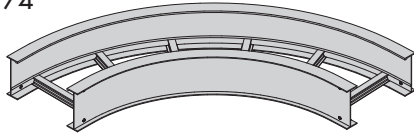

## Horizontal Tee

Pages 75 - 76

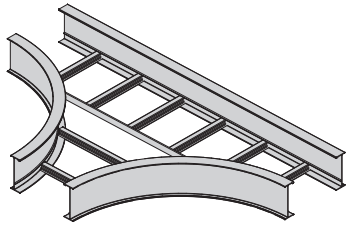

## Horizontal Cross

Pages 77 - 78

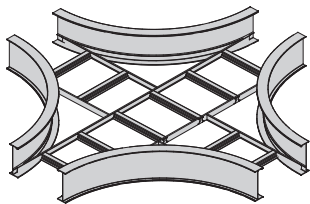

## Reducers

Page 79

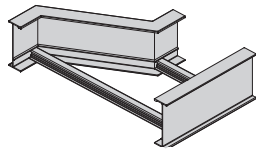

## 45° "Y" Branch

Page 80

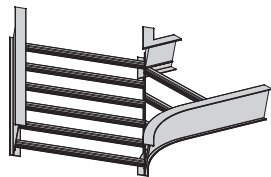

## Vertical Elbows

Pages 81 - 84

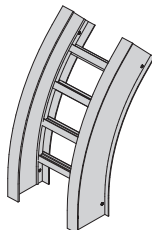

## Vertical Tee & 90° Vertical Support Elbow

Page 85

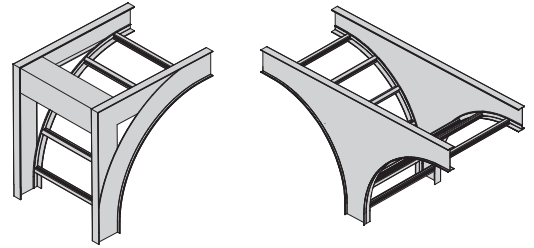

## Connectors & Hardware

Pages 86 - 89

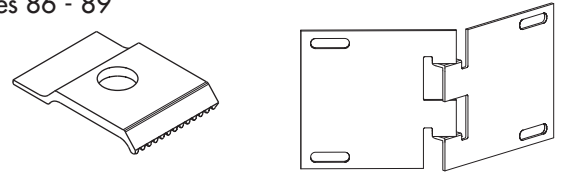

## Covers

Page 90

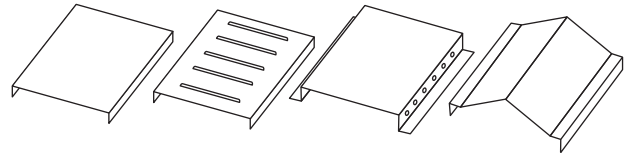

## Cover Attachments

Page 91

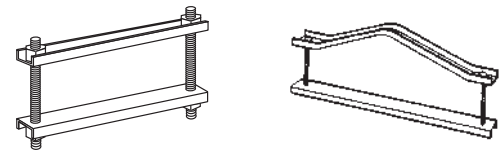

## Accessories

Pages 92 - 93

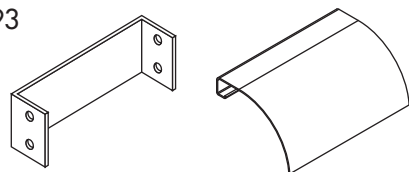

## Barrier Strips & Accessories

Page 94

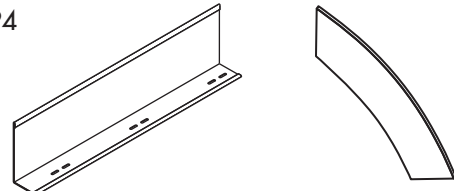

## Brackets & Hangers

Pages 95 - 97

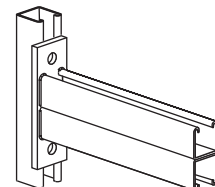

# I-BEAM CABLE TRAY SYSTEM



## SELECTION CHART: Aluminum Tray

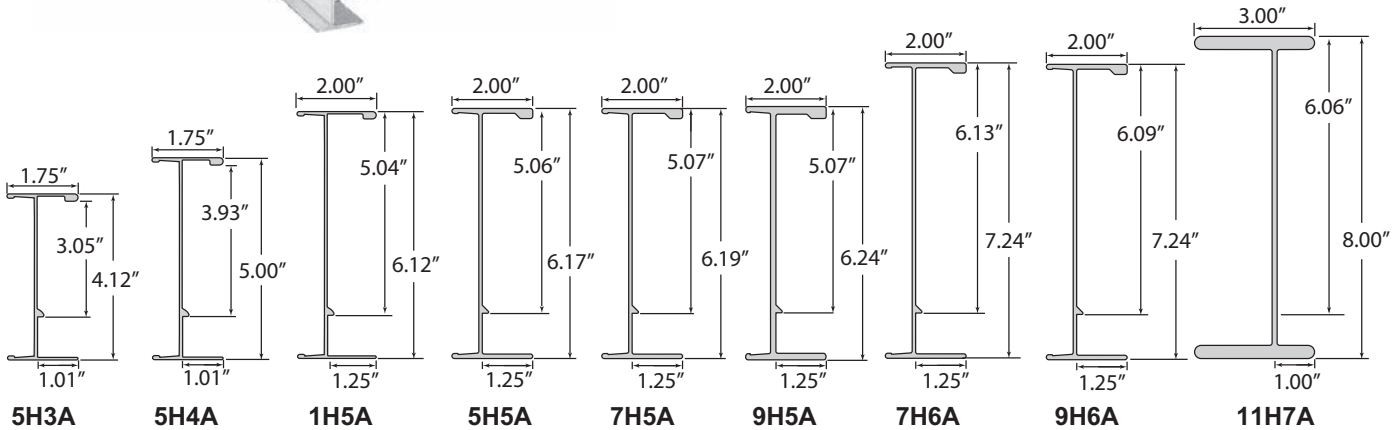

### NEMA CLASS, PHYSICAL AND STRUCTURAL PROPERTIES

| NEMA Standard VE-1 Load/ Span Class | NEMA Ld/Span         | Cope System Number | Actual Load Depth | Side Rail Height | Flange Width (in.) | Sect. Mod. of 2 Rails Sx (in. <sup>3</sup> ) | Moment of Inertia for 2 Rails Ix (in. <sup>4</sup> ) | Min X-Sect. Area of 2 Rails per NEC 392.7 (in. <sup>2</sup> ) |
|-------------------------------------|----------------------|--------------------|-------------------|------------------|--------------------|--|--|---|
| 12C                                 | 100 lb./ft. 12' span | 5H3A               | 3.05" (77mm)      | 4.12" (105mm)    | 1¾                 | 1.48   | 3.10   | 1.18  |
| 12C                                 | 100 lb./ft. 12' span | 5H4A               | 3.93" (100mm)     | 5" (127mm)       | 1¾                 | 1.93   | 4.90   | 1.30  |
| 16A                                 | 50 lb./ft. 16' span  | 5H3A               | 3.05" (77mm)      | 4.12" (105mm)    | 1¾                 | 1.48   | 3.10   | 1.18  |
| 16A                                 | 50 lb./ft. 16' span  | 5H4A               | 3.93" (100mm)     | 5" (127mm)       | 1¾                 | 1.93   | 4.90   | 1.30  |
| 16B                                 | 75 lb./ft. 16' span  | 1H5A               | 5.04" (128mm)     | 6.12" (155mm)    | 2                  | 2.53   | 7.92   | 1.41  |
| 16C                                 | 100 lb./ft. 16' span | 5H5A               | 5.06" (129mm)     | 6.17" (157mm)    | 2                  | 3.36   | 10.85  | 1.81  |
| 20A                                 | 50 lb./ft. 20' span  | 1H5A               | 5.04" (128mm)     | 6.12" (155mm)    | 2                  | 2.53   | 7.92   | 1.41  |
| 20B                                 | 75 lb./ft. 20' span  | 5H5A               | 5.06" (129mm)     | 6.17" (157mm)    | 2                  | 3.36   | 10.85  | 1.81  |
| 20C                                 | 100 lb./ft. 20' span | 7H5A               | 5.07" (129mm)     | 6.19" (157mm)    | 2                  | 3.85   | 12.44  | 2.00  |
| 20C                                 | 100 lb./ft. 20' span | 7H6A               | 6.13" (156mm)     | 7.24" (184mm)    | 2                  | 4.94   | 17.88  | 2.38  |
| 20C+                                | 100 lb./ft. 24' span | 9H5A               | 5.07" (129mm)     | 6.24" (158mm)    | 2                  | 5.34   | 17.52  | 2.00  |
| 20C+                                | 100 lb./ft. 24' span | 9H6A               | 6.09" (155mm)     | 7.24" (184mm)    | 2                  | 6.10   | 22.91  | 3.04  |
| 30C                                 | 100 lb./ft. 30' span | 11H7A              | 6.06" (154mm)     | 8" (203mm)       | 3                  | 16.17  | 64.69  | 5.67  |

Note: Special Applications Available. Please Contact Factory.

### MATERIAL & FINISH SPECIFICATIONS (I-BEAM Cable Tray)

| Item      | Aluminum  | Item                | Aluminum                                 |
|-----------|---|---------------------|--|
| Siderails | AA-6063-T6 Extruded   | Splice Plate Finish | AA-5052-H34                              |
| Rungs     | AA-6063-T6 Extruded*<br>AA-6063-T832 Extruded*<br>AA-6063-T52 Extruded* | Connector Bolts     | SAE J429 Grade 1<br>(ASTM A-307 Grade A) |
| Covers    | AA-3003 H14 or 3150 H14   | Bolt Plating        | ASTM B-633.0002" Zinc                    |

\*Special High Strength 32 ksi Minimum Yield

**LOAD AND DEFLECTION DATA FOR ALUMINUM LADDER**  
Working (Allowable) Load Capacity, Evenly Distributed-Tested per NEMA Standard VE-1,  
Simple Beam - SAFETY FACTOR 1.5

| AB-Cope System No. | NEMA      | UL COMPLIANCE | UL COMPLIANCE | CSA COMPLIANCE | SPAN  |      |        |       |      |        |       |      |       |       |      |       |
|--------------------|-----------|---------------|---------------|----------------|-------|------|--------|-------|------|--------|-------|------|-------|-------|------|-------|
|                    |           |               |               |                | 6 Ft  |      |        | 8 Ft  |      |        | 10 Ft |      |       | 12 Ft |      |       |
|                    |           |               |               |                | w     | d    | k      | w     | d    | k      | w     | d    | k     | w     | d    | k     |
| 5H3A               | 16A & 12C | ✓             |               |                | 455   | 0.52 | 0.001  | 256   | 0.93 | 0.004  | 164   | 1.46 | 0.009 | 114   | 2.10 | 0.018 |
| 5H4A               | 16A & 12C | ✓             |               |                | 505   | 0.33 | 0.001  | 284   | 0.58 | 0.002  | 182   | 0.91 | 0.005 | 126   | 1.31 | 0.010 |
| 1H5A               | 16B & 20A | ✓             | ✓             |                | 555   | 0.21 | 0.0004 | 319   | 0.36 | 0.001  | 204   | 0.57 | 0.003 | 142   | 0.85 | 0.006 |
| 5H5A               | 16C & 20B | ✓             | ✓             |                | 917   | 0.25 | 0.0003 | 527   | 0.44 | 0.001  | 337   | 0.69 | 0.002 | 233   | 1.00 | 0.004 |
| 7H5A               | 20C       | ✓             | ✓             | ✓              | 1,178 | 0.27 | 0.0002 | 663   | 0.47 | 0.001  | 424   | 0.74 | 0.002 | 294   | 1.07 | 0.004 |
| 9H5A               | 20C+      | ✓             | ✓             | ✓              | 1,889 | 0.32 | 0.0002 | 1,063 | 0.57 | 0.001  | 680   | 0.89 | 0.001 | 472   | 1.28 | 0.003 |
| 7H6A               | 20C       | ✓             | ✓             |                | 1,105 | 0.18 | 0.0002 | 622   | 0.32 | 0.001  | 398   | 0.50 | 0.001 | 276   | 0.72 | 0.003 |
| 9H6A               | 20C+      | ✓             | ✓             |                | 1,656 | 0.21 | 0.0001 | 932   | 0.37 | 0.0004 | 596   | 0.58 | 0.001 | 413   | 0.84 | 0.002 |

**Note:** Contact your AB-Cope representative for loading information on the 11H7A system

To convert 1.5 safety factor to 2.0 multiply w, d, k by .75

w = Pounds per linear foot

d = Deflections (inches)

k = Deflection (in.) for each pound of load

t = Denotes k is less than .001 inch

| ABCope System No. | NEMA      | UL COMPLIANCE | UL COMPLIANCE | CSA COMPLIANCE | SPAN (cont.) |      |       |       |      |       |       |      |       |       |      |       |
|-------------------|-----------|---------------|---------------|----------------|--------------|------|-------|-------|------|-------|-------|------|-------|-------|------|-------|
|                   |           |               |               |                | 16 Ft        |      |       | 20 Ft |      |       | 24 Ft |      |       | 25 Ft |      |       |
|                   |           |               |               |                | w            | d    | k     | w     | d    | k     | w     | d    | k     | w     | d    | k     |
| 5H3A              | 16A & 12C | ✓             |               |                | 64           | 3.73 | 0.058 | -     | -    | -     | -     | -    | -     | -     | -    | -     |
| 5H4A              | 16A & 12C | ✓             |               |                | 71           | 2.33 | 0.033 | -     | -    | -     | -     | -    | -     | -     | -    | -     |
| 1H5A              | 16B & 20A | ✓             | ✓             |                | 80           | 1.52 | 0.019 | 51    | 2.30 | 0.045 | -     | -    | -     | -     | -    | -     |
| 5H5A              | 16C & 20B | ✓             | ✓             |                | 131          | 1.83 | 0.014 | 84    | 2.77 | 0.033 | -     | -    | -     | -     | -    | -     |
| 7H5A              | 20C       | ✓             | ✓             | ✓              | 166          | 1.89 | 0.011 | 106   | 2.96 | 0.028 | 73    | 4.20 | 0.058 | -     | -    | -     |
| 9H5A              | 20C+      | ✓             | ✓             | ✓              | 266          | 2.27 | 0.009 | 170   | 3.55 | 0.021 | 117   | 5.04 | 0.043 | 108   | 5.48 | 0.51  |
| 7H6A              | 20C       | ✓             | ✓             |                | 156          | 1.28 | 0.008 | 100   | 2.01 | 0.020 | 69    | 2.88 | 0.042 | -     | -    | -     |
| 9H6A              | 20C+      | ✓             | ✓             |                | 233          | 1.49 | 0.006 | 149   | 2.38 | 0.016 | 103   | 3.40 | 0.033 | 95    | 3.61 | 0.038 |

**Note:** Contact your AB-Cope representative for loading information on the 11H7A system

To convert 1.5 safety factor to 2.0 multiply w, d, k by .75

w = Pounds per linear foot

d = Deflections (inches)

k = Deflection (in.) for each pound of load

t = Denotes k is less than .001 inch

## PART NUMBERING SYSTEM:

Please pay careful attention to the part numbering structure. Example: Catalog No. 5H4A-06SL-12-09 is a 4" load depth aluminum ladder with an I-Beam flange, 6 inches wide, straight length 12 feet long, rungs on 9" centers. Please make sure to use the system numbers from pages 66 and 67 when ordering.

### Straight Length

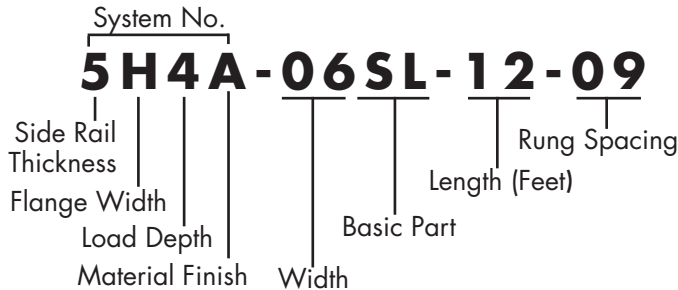

### Fittings

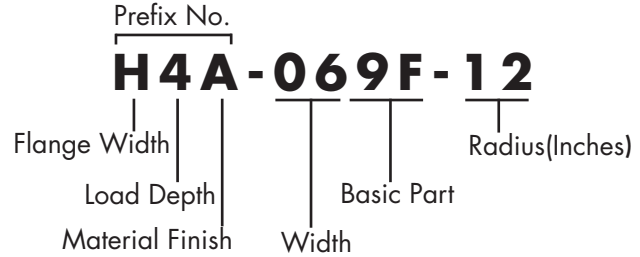

### SYSTEM NUMBER (STRAIGHT SECTION ONLY) –

The first four digits make up the system number which identifies the structural, dimensional and material characteristics of the straight length. It is made up of the side rail digits indicating the side rail thickness and flange design, the load depth (inside, in inches) and material finish (aluminum).

- 1H5A:** 3 Thick, I-Beam Rail, 5" Load Depth, Aluminum
- 5H3A:** 5 Thick, I-Beam Rail, 3" Load Depth, Aluminum
- 5H4A:** 5 Thick, I-Beam Rail, 4" Load Depth, Aluminum
- 5H5A:** 5 Thick, I-Beam Rail, 5" Load Depth, Aluminum
- 7H5A:** 7 Thick, I-Beam Rail, 5" Load Depth, Aluminum
- 7H6A:** 7 Thick, I-Beam Rail, 6" Load Depth, Aluminum
- 9H5A:** 9 Thick, I-Beam Rail, 5" Load Depth, Aluminum
- 9H6A:** 9 Thick, I-Beam Rail, 6" Load Depth, Aluminum
- 11H7A:** 11 Thick, I-Beam Rail, 7" Load Depth, Aluminum

**PREFIX NUMBER (FITTINGS ONLY) –** Fittings are ordered using the 3-digit prefix number given in the charts on the fitting pages.

- H3A:** I-Beam Rail, 3" Load Depth, Aluminum
- H4A:** I-Beam Rail, 4" Load Depth, Aluminum
- H5A:** I-Beam Rail, 5" Load Depth, Aluminum
- H6A:** I-Beam Rail, 6" Load Depth, Aluminum
- H7A:** I-Beam Rail, 7" Load Depth, Aluminum

**WIDTH –** The inside width of the tray.

- 06:** 6" Width (152mm)
- 09:** 9" Width (229mm)
- 12:** 12" Width (305mm)
- 18:** 18" Width (457mm)
- 24:** 24" Width (610mm)
- 30:** 30" Width (762mm)
- 36:** 36" Width (914mm)

**Length (STRAIGHT SECTION ONLY) –** The length of the tray in feet.

- 12:** 12' Length (3.7m)
- 20:** 20' Length (6.1m)
- 24:** 24' Length (7.3m)
- 30:** 30' Length (9.1m)

**BASIC PART NUMBER –** Identifies the straight length, fitting, or accessory.

- SL:** Straight Length
- 9F:** 90° Horizontal Elbow
- 6F:** 60° Horizontal Elbow
- 4F:** 45° Horizontal Elbow
- 3F:** 30° Horizontal Elbow
- 9O:** 90° Vertical Outside Elbow
- 6O:** 60° Vertical Outside Elbow
- 4O:** 45° Vertical Outside Elbow
- 3O:** 30° Vertical Outside Elbow
- 9I:** 90° Vertical Inside Elbow
- 6I:** 60° Vertical Inside Elbow
- 4I:** 45° Vertical Inside Elbow
- 3I:** 30° Vertical Inside Elbow
- FT:** Horizontal Tee
- TT:** Horizontal Tapped Tee
- FC:** Horizontal Cross
- TC:** Horizontal Tapped Cross
- VT:** Vertical Tee
- SR:** Vertical Cable Support Elbow
- ST:** Straight Reducer
- RH:** Right Hand Reducer
- LH:** Left Hand Reducer
- RY:** 45°"Y" Right Hand Branch
- LY:** 45°"Y" Left Hand Branch

**RUNG SPACING –** The center-to-center distance between rungs on straight length. Rung spacing is maintained through centerline of all fittings.

- 09:** 9" Nominal (229<sub>mm</sub>) rung spacing

**Radius (FITTINGS ONLY) –** The radius of bend.

- 12:** 12" Length (305mm)
- 24:** 24" Length (610mm)
- 36:** 36" Length (914mm)

## I-Beam Fittings

Fittings are used to change the size or direction of the cable tray. A wide variety of standard fittings are offered to simplify installation of a tray system. Horizontal or vertical bends are offered for each tray width and with angles of 30°, 45°, 60° or 90°. The radius of the bend, whether horizontal or vertical, can be 12", 24", 36", or even greater on a custom basis. Specification of the radius of the bend involves a trade-off between available space, minimum bending radius of cables, ease of cable pulling, and cost. The most common radius is 24 in. Fittings are not subject to NEMA/CSA load ratings and the diagrams below illustrate how the tray should be supported near the fittings.

When a standard angle will not work, field fittings or adjustable elbows can be used. Refer to NEMA VE2 Installation Guidelines for suggested support locations for these situations.

### Support for Flat Fittings

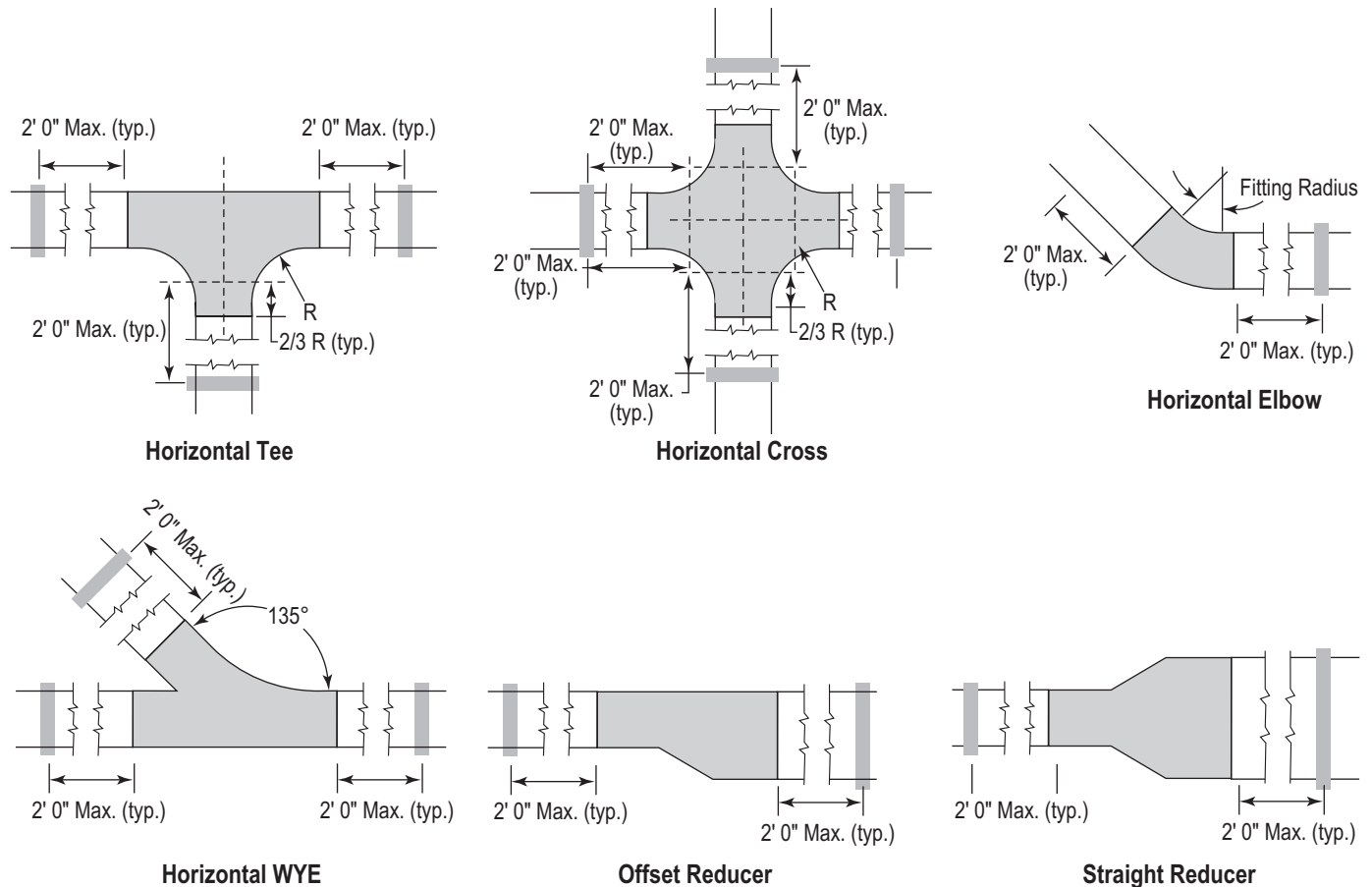

### Support for Vertical Fittings

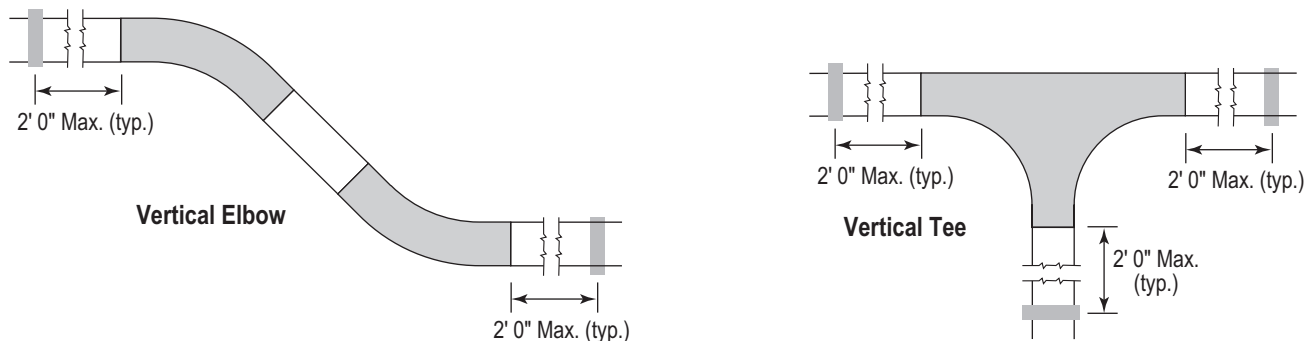

## 90° Horizontal Elbow [9F]

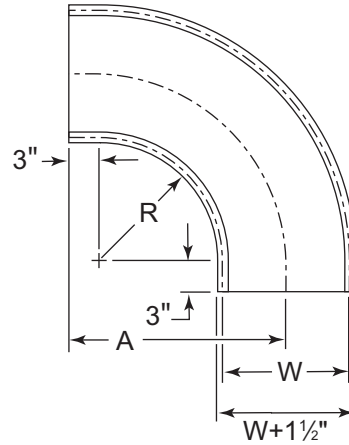
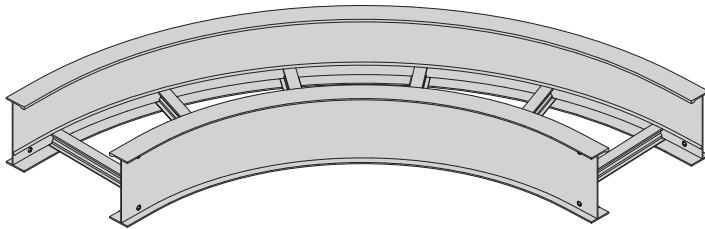

| Radius - R            | Width - W    | "A" Dimension    |
|-----------------------|--------------|------------------|
| <b>12"</b><br>(305mm) | 6" (152mm)   | 18" (457mm)      |
|                       | 9" (229mm)   | 19 1/2" (495mm)  |
|                       | 12" (305mm)  | 21" (533mm)      |
|                       | 18" (457mm)  | 24" (610mm)      |
|                       | 24" (610mm)  | 27" (686mm)      |
|                       | 30" (762mm)  | 30" (762mm)      |
| <b>24"</b><br>(610mm) | 6" (152mm)   | 30" (762mm)      |
|                       | 9" (229mm)   | 31 1/2" (800mm)  |
|                       | 12" (305mm)  | 33" (838mm)      |
|                       | 18" (457mm)  | 36" (914mm)      |
|                       | 24" (610mm)  | 39" (991mm)      |
|                       | 30" (762mm)  | 42" (1067mm)     |
| <b>36"</b><br>(914mm) | 6" (152mm)   | 42" (1067mm)     |
|                       | 9" (229mm)   | 43 1/2" (1105mm) |
|                       | 12" (305mm)  | 45" (1143mm)     |
|                       | 18" (457mm)  | 48" (1219mm)     |
|                       | 24" (610mm)  | 51" (1295mm)     |
|                       | 30" (762mm)  | 54" (1372mm)     |
| 36" (914mm)           | 57" (1448mm) |                  |

EXAMPLE: H4A-129F-12

**Note:** Nominal 9" rung spacing maintained through centerline of all fittings.

### Ordering Information:



See Page 98  
 for Electrical  
 Grounding Chart

## 60° Horizontal Elbow [6F]

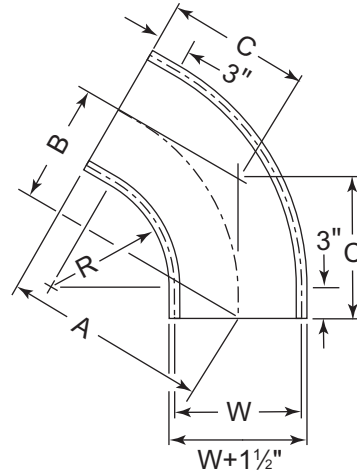
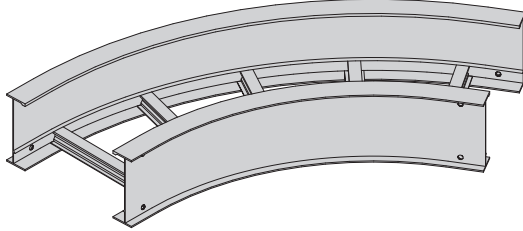

| Radius - R     | Width - W   | "A" Dimension      | "B" Dimension   | "C" Dimension     |
|----------------|-------------|--------------------|-----------------|-------------------|
| 12"<br>(305mm) | 6" (152mm)  | 17 1/2" (445mm)    | 10 1/8" (257mm) | 11 11/16" (297mm) |
|                | 9" (229mm)  | 18 13/16" (478mm)  | 10 7/8" (276mm) | 12 1/2" (318mm)   |
|                | 12" (305mm) | 20 1/16" (510mm)   | 11 5/8" (295mm) | 13 3/8" (340mm)   |
|                | 18" (457mm) | 22 11/16" (576mm)  | 13 1/8" (333mm) | 15 1/8" (384mm)   |
|                | 24" (610mm) | 25 5/16" (643mm)   | 14 5/8" (371mm) | 16 7/8" (429mm)   |
|                | 30" (762mm) | 27 7/8" (708mm)    | 16 1/8" (410mm) | 18 9/16" (471mm)  |
|                | 36" (914mm) | 30 1/2" (775mm)    | 17 5/8" (448mm) | 20 5/16" (516mm)  |
| 24"<br>(610mm) | 6" (152mm)  | 27 7/8" (708mm)    | 16 1/8" (410mm) | 18 9/16" (471mm)  |
|                | 9" (229mm)  | 29 3/16" (741mm)   | 16 7/8" (429mm) | 19 7/16" (494mm)  |
|                | 12" (305mm) | 30 1/2" (775mm)    | 17 5/8" (448mm) | 20 5/16" (516mm)  |
|                | 18" (457mm) | 33 1/16" (840mm)   | 19 1/8" (486mm) | 22 1/16" (560mm)  |
|                | 24" (610mm) | 35 11/16" (906mm)  | 20 5/8" (524mm) | 23 13/16" (605mm) |
|                | 30" (762mm) | 38 1/4" (972mm)    | 22 1/8" (562mm) | 25 1/2" (648mm)   |
|                | 36" (914mm) | 40 7/8" (1038mm)   | 23 5/8" (600mm) | 27 1/4" (692mm)   |
| 36"<br>(914mm) | 6" (152mm)  | 38 1/4" (972mm)    | 22 1/8" (562mm) | 25 1/2" (648mm)   |
|                | 9" (229mm)  | 39 9/16" (1005mm)  | 22 7/8" (581mm) | 26 3/8" (670mm)   |
|                | 12" (305mm) | 40 7/8" (1038mm)   | 23 5/8" (600mm) | 27 1/4" (692mm)   |
|                | 18" (457mm) | 43 1/2" (1105mm)   | 25 1/8" (638mm) | 29" (737mm)       |
|                | 24" (610mm) | 46 1/16" (1170mm)  | 26 5/8" (676mm) | 30 11/16" (779mm) |
|                | 30" (762mm) | 48 11/16" (1237mm) | 28 1/8" (714mm) | 32 7/16" (824mm)  |
|                | 36" (914mm) | 51 1/4" (1302mm)   | 29 5/8" (752mm) | 34 3/16" (868mm)  |

EXAMPLE: H4A-126F-12

**Note:** Nominal 9" rung spacing maintained through centerline of all fittings.

### Ordering Information:

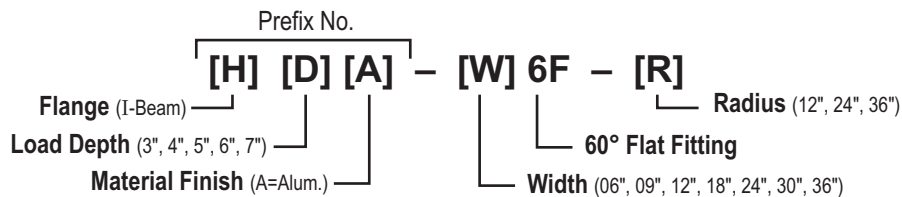

See Page 98  
for Electrical  
Grounding Chart

## 45° Horizontal Elbow [4F]

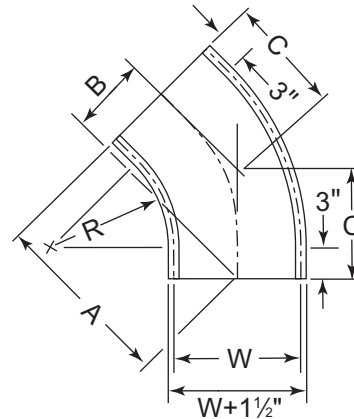
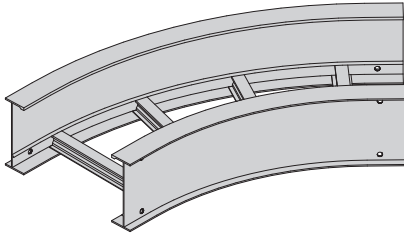

| Radius - R            | Width - W   | "A" Dimension     | "B" Dimension     | "C" Dimension     |
|-----------------------|-------------|-------------------|-------------------|-------------------|
| <b>12"</b><br>(305mm) | 6" (152mm)  | 15 3/4" (400mm)   | 6 1/2" (165mm)    | 9 3/16" (233mm)   |
|                       | 9" (229mm)  | 16 13/16" (427mm) | 6 15/16" (176mm)  | 9 13/16" (249mm)  |
|                       | 12" (305mm) | 17 7/8" (454mm)   | 7 3/8" (187mm)    | 10 7/16" (265mm)  |
|                       | 18" (457mm) | 20" (508mm)       | 8 1/4" (210mm)    | 11 1/16" (297mm)  |
|                       | 24" (610mm) | 22 1/4" (560mm)   | 9 1/8" (232mm)    | 12 15/16" (329mm) |
|                       | 30" (762mm) | 24 3/16" (614mm)  | 10" (254mm)       | 14 3/16" (360mm)  |
| <b>24"</b><br>(610mm) | 36" (914mm) | 26 5/16" (668mm)  | 10 15/16" (278mm) | 15 7/16" (392mm)  |
|                       | 6" (152mm)  | 24 3/16" (614mm)  | 10" (254mm)       | 14 3/16" (360mm)  |
|                       | 9" (229mm)  | 25 1/4" (641mm)   | 10 1/2" (267mm)   | 14 13/16" (376mm) |
|                       | 12" (305mm) | 26 5/16" (668mm)  | 10 15/16" (278mm) | 15 7/16" (392mm)  |
|                       | 18" (457mm) | 28 7/16" (722mm)  | 11 13/16" (300mm) | 16 11/16" (424mm) |
|                       | 24" (610mm) | 30 9/16" (776mm)  | 12 11/16" (322mm) | 17 15/16" (456mm) |
| <b>36"</b><br>(914mm) | 30" (762mm) | 32 11/16" (830mm) | 13 9/16" (344mm)  | 19 1/8" (486mm)   |
|                       | 36" (914mm) | 34 13/16" (884mm) | 14 7/16" (367mm)  | 20 3/8" (518mm)   |
|                       | 6" (152mm)  | 32 11/16" (830mm) | 13 9/16" (344mm)  | 19 1/8" (486mm)   |
|                       | 9" (229mm)  | 33 3/4" (857mm)   | 14" (356mm)       | 19 3/4" (502mm)   |
|                       | 12" (305mm) | 34 13/16" (884mm) | 14 7/16" (367mm)  | 20 3/8" (518mm)   |
|                       | 18" (457mm) | 36 15/16" (938mm) | 15 5/16" (389mm)  | 21 5/8" (549mm)   |
| <b>36"</b><br>(914mm) | 24" (610mm) | 39 1/16" (992mm)  | 16 3/16" (411mm)  | 22 7/8" (581mm)   |
|                       | 30" (762mm) | 41 3/16" (1046mm) | 17 1/16" (433mm)  | 24 1/8" (613mm)   |
|                       | 36" (914mm) | 43 5/16" (1100mm) | 17 15/16" (456mm) | 25 3/8" (645mm)   |

EXAMPLE: H4A-124F-12

**Note:** Nominal 9" rung spacing maintained through centerline of all fittings.

### Ordering Information:



See Page 98  
 for Electrical  
 Grounding Chart

## 30° Horizontal Elbow [3F]

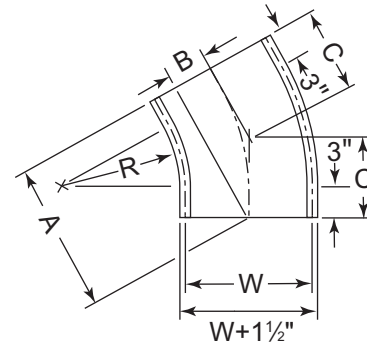
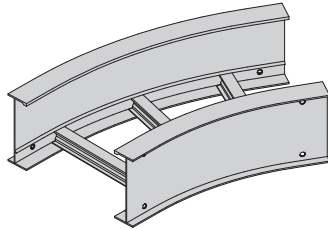

| Radius - R            | Width - W   | "A" Dimension   | "B" Dimension    | "C" Dimension     |
|-----------------------|-------------|-----------------|------------------|-------------------|
| <b>12"</b><br>(305mm) | 6" (152mm)  | 13 1/8" (333mm) | 3 1/2" (89mm)    | 7" (178mm)        |
|                       | 9" (229mm)  | 13 7/8" (352mm) | 3 11/16" (94mm)  | 7 7/16" (189mm)   |
|                       | 12" (305mm) | 14 5/8" (371mm) | 3 15/16" (100mm) | 7 13/16" (198mm)  |
|                       | 18" (457mm) | 16 1/8" (410mm) | 4 5/16" (110mm)  | 8 5/8" (219mm)    |
|                       | 24" (610mm) | 17 5/8" (448mm) | 4 11/16" (119mm) | 9 7/16" (240mm)   |
|                       | 30" (762mm) | 19 1/8" (486mm) | 5 1/8" (130mm)   | 10 1/4" (260mm)   |
| <b>24"</b><br>(610mm) | 36" (914mm) | 20 5/8" (524mm) | 5 1/2" (140mm)   | 11 1/16" (281mm)  |
|                       | 6" (152mm)  | 19 1/8" (486mm) | 5 1/8" (130mm)   | 10 1/4" (260mm)   |
|                       | 9" (229mm)  | 19 7/8" (505mm) | 5 5/16" (135mm)  | 10 5/8" (270mm)   |
|                       | 12" (305mm) | 20 5/8" (524mm) | 5 1/2" (140mm)   | 11 1/16" (281mm)  |
|                       | 18" (457mm) | 22 1/8" (562mm) | 5 15/16" (151mm) | 11 13/16" (300mm) |
|                       | 24" (610mm) | 23 5/8" (600mm) | 6 5/16" (160mm)  | 12 5/8" (321mm)   |
| <b>36"</b><br>(914mm) | 30" (762mm) | 25 1/8" (638mm) | 6 3/4" (171mm)   | 13 7/16" (341mm)  |
|                       | 36" (914mm) | 26 5/8" (676mm) | 7 1/8" (181mm)   | 14 1/4" (362mm)   |
|                       | 6" (152mm)  | 25 1/8" (638mm) | 6 3/4" (171mm)   | 13 7/16" (341mm)  |
|                       | 9" (229mm)  | 25 7/8" (657mm) | 6 15/16" (176mm) | 13 7/8" (352mm)   |
|                       | 12" (305mm) | 26 5/8" (676mm) | 7 1/8" (181mm)   | 14 1/4" (362mm)   |
|                       | 18" (457mm) | 28 1/8" (714mm) | 7 1/2" (191mm)   | 15 1/16" (383mm)  |
| <b>36"</b><br>(914mm) | 24" (610mm) | 29 5/8" (752mm) | 7 15/16" (202mm) | 15 7/8" (403mm)   |
|                       | 30" (762mm) | 31 1/8" (791mm) | 8 5/16" (211mm)  | 16 11/16" (424mm) |
|                       | 36" (914mm) | 32 5/8" (829mm) | 8 3/4" (222mm)   | 17 1/2" (445mm)   |

EXAMPLE: H4A-123F-12

**Note:** Nominal 9" rung spacing maintained through centerline of all fittings.

### Ordering Information:



See Page 98  
 for Electrical  
 Grounding Chart

## Horizontal Tee [FT]

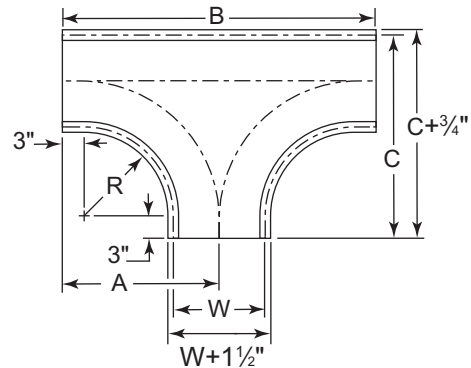
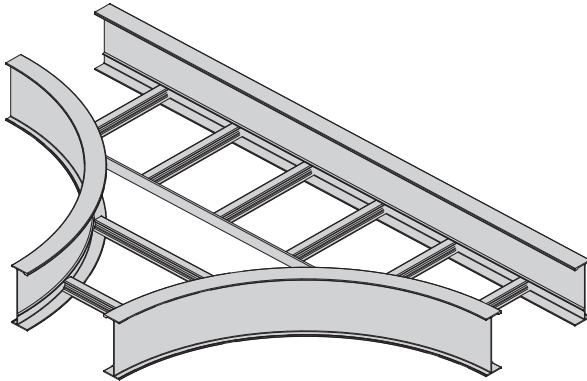

| Radius - R            | Width - W    | "A" Dimension    | "B" Dimension | "C" Dimension |
|-----------------------|--------------|------------------|---------------|---------------|
| <b>12"</b><br>(305mm) | 6" (152mm)   | 18" (457mm)      | 36" (914mm)   | 21" (533mm)   |
|                       | 9" (229mm)   | 19 1/2" (495mm)  | 39" (991mm)   | 24" (610mm)   |
|                       | 12" (305mm)  | 21" (533mm)      | 42" (1067mm)  | 27" (686mm)   |
|                       | 18" (457mm)  | 24" (610mm)      | 48" (1219mm)  | 33" (838mm)   |
|                       | 24" (610mm)  | 27" (686mm)      | 54" (1372mm)  | 39" (991mm)   |
|                       | 30" (762mm)  | 30" (762mm)      | 60" (1524mm)  | 45" (1143mm)  |
| <b>24"</b><br>(610mm) | 6" (152mm)   | 30" (762mm)      | 60" (1524mm)  | 33" (838mm)   |
|                       | 9" (229mm)   | 31 1/2" (800mm)  | 63" (1600mm)  | 36" (914mm)   |
|                       | 12" (305mm)  | 33" (838mm)      | 66" (1676mm)  | 39" (991mm)   |
|                       | 18" (457mm)  | 36" (914mm)      | 72" (1829mm)  | 45" (1143mm)  |
|                       | 24" (610mm)  | 39" (991mm)      | 78" (1981mm)  | 51" (1295mm)  |
|                       | 30" (762mm)  | 42" (1067mm)     | 84" (2134mm)  | 57" (1448mm)  |
| <b>36"</b><br>(914mm) | 6" (152mm)   | 42" (1067mm)     | 84" (2134mm)  | 45" (1143mm)  |
|                       | 9" (229mm)   | 43 1/2" (1105mm) | 87" (2210mm)  | 48" (1219mm)  |
|                       | 12" (305mm)  | 45" (1143mm)     | 90" (2286mm)  | 51" (1295mm)  |
|                       | 18" (457mm)  | 48" (1219mm)     | 96" (2438mm)  | 57" (1448mm)  |
|                       | 24" (610mm)  | 51" (1295mm)     | 102" (2591mm) | 63" (1600mm)  |
|                       | 30" (762mm)  | 54" (1372mm)     | 108" (2743mm) | 69" (1753mm)  |
| 36" (914mm)           | 57" (1448mm) | 114" (2896mm)    | 75" (1905mm)  |               |

EXAMPLE: H4A-12FT-12

**Note:** Nominal 9" rung spacing maintained through centerline of all fittings.

### Ordering Information:



See Page 98  
for Electrical  
Grounding Chart

## Horizontal Tapped Tee [TT]

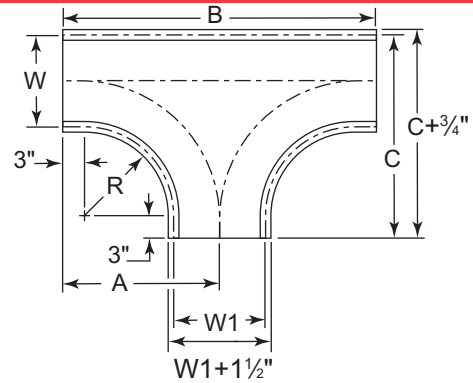
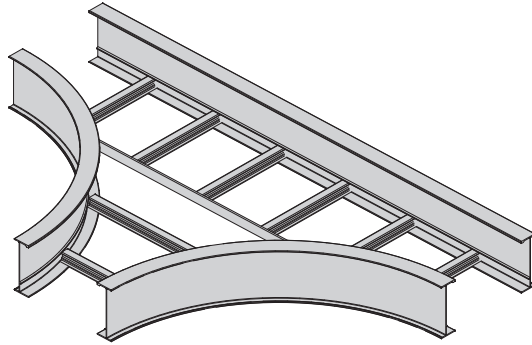

| R<br>Radius    | W<br>Width  | W1<br>Width     | "A"<br>Dimension | "C"<br>Dimension |
|----------------|-------------|-----------------|------------------|------------------|
| 12"<br>(305mm) | 36" (914mm) | 30" (762mm)     | 27" (686mm)      | 48" (1219mm)     |
|                | 36" (914mm) | 24" (610mm)     | 24" (610mm)      | 48" (1219mm)     |
|                | 36" (914mm) | 18" (457mm)     | 21" (533mm)      | 48" (1219mm)     |
|                | 36" (914mm) | 12" (305mm)     | 18" (457mm)      | 48" (1219mm)     |
|                | 36" (914mm) | 9" (229mm)      | 16 1/2" (419mm)  | 48" (1219mm)     |
|                | 36" (914mm) | 6" (152mm)      | 15" (381mm)      | 48" (1219mm)     |
|                | 30" (762mm) | 24" (610mm)     | 24" (610mm)      | 42" (1067mm)     |
|                | 30" (762mm) | 18" (457mm)     | 21" (533mm)      | 42" (1067mm)     |
|                | 30" (762mm) | 12" (305mm)     | 18" (457mm)      | 42" (1067mm)     |
|                | 30" (762mm) | 9" (229mm)      | 16 1/2" (419mm)  | 42" (1067mm)     |
|                | 30" (762mm) | 6" (152mm)      | 15" (381mm)      | 42" (1067mm)     |
|                | 18" (457mm) | 12" (305mm)     | 18" (457mm)      | 30" (762mm)      |
| 18" (457mm)    | 9" (229mm)  | 16 1/2" (419mm) | 30" (762mm)      |                  |
| 18" (457mm)    | 6" (152mm)  | 15" (381mm)     | 30" (762mm)      |                  |
| 12" (305mm)    | 9" (229mm)  | 16 1/2" (419mm) | 24" (610mm)      |                  |
| 12" (305mm)    | 6" (152mm)  | 15" (381mm)     | 24" (610mm)      |                  |
| 9" (229mm)     | 6" (152mm)  | 15" (381mm)     | 21" (533mm)      |                  |
| 24"<br>(610mm) | 36" (914mm) | 30" (762mm)     | 39" (991mm)      | 60" (1524mm)     |
|                | 36" (914mm) | 24" (610mm)     | 36" (914mm)      | 60" (1524mm)     |
|                | 36" (914mm) | 18" (457mm)     | 33" (838mm)      | 60" (1524mm)     |
|                | 36" (914mm) | 12" (305mm)     | 30" (762mm)      | 60" (1524mm)     |
|                | 36" (914mm) | 9" (229mm)      | 28 1/2" (724mm)  | 60" (1524mm)     |
|                | 36" (914mm) | 6" (152mm)      | 27" (686mm)      | 60" (1524mm)     |
|                | 30" (762mm) | 24" (610mm)     | 36" (914mm)      | 54" (1372mm)     |
|                | 30" (762mm) | 18" (457mm)     | 33" (838mm)      | 54" (1372mm)     |
|                | 30" (762mm) | 12" (305mm)     | 30" (762mm)      | 54" (1372mm)     |
|                | 30" (762mm) | 9" (229mm)      | 28 1/2" (724mm)  | 54" (1372mm)     |
|                | 30" (762mm) | 6" (152mm)      | 27" (686mm)      | 54" (1372mm)     |

| R<br>Radius               | W<br>Width     | W1<br>Width      | "A"<br>Dimension | "C"<br>Dimension |              |
|---------------------------|----------------|------------------|------------------|------------------|--------------|
| 24"<br>(610mm)<br>(Cont.) | 24" (610mm)    | 18" (457mm)      | 33" (838mm)      | 48" (1219mm)     |              |
|                           | 24" (610mm)    | 12" (305mm)      | 30" (762mm)      | 48" (1219mm)     |              |
|                           | 24" (610mm)    | 9" (229mm)       | 28 1/2" (724mm)  | 48" (1219mm)     |              |
|                           | 24" (610mm)    | 6" (152mm)       | 27" (686mm)      | 48" (1219mm)     |              |
|                           | 18" (457mm)    | 12" (305mm)      | 30" (762mm)      | 42" (1067mm)     |              |
|                           | 18" (457mm)    | 9" (229mm)       | 28 1/2" (724mm)  | 42" (1067mm)     |              |
|                           | 18" (457mm)    | 6" (152mm)       | 27" (686mm)      | 42" (1067mm)     |              |
|                           | 12" (305mm)    | 9" (229mm)       | 28 1/2" (724mm)  | 36" (914mm)      |              |
|                           | 12" (305mm)    | 6" (152mm)       | 27" (686mm)      | 36" (914mm)      |              |
|                           | 9" (229mm)     | 6" (152mm)       | 27" (686mm)      | 33" (838mm)      |              |
|                           | 36"<br>(914mm) | 36" (914mm)      | 30" (762mm)      | 51" (1295mm)     | 72" (1829mm) |
|                           |                | 36" (914mm)      | 24" (610mm)      | 48" (1219mm)     | 72" (1829mm) |
| 36" (914mm)               |                | 18" (457mm)      | 45" (1143mm)     | 72" (1829mm)     |              |
| 36" (914mm)               |                | 12" (305mm)      | 42" (1067mm)     | 72" (1829mm)     |              |
| 36" (914mm)               |                | 9" (229mm)       | 40 1/2" (1029mm) | 72" (1829mm)     |              |
| 36" (914mm)               |                | 6" (152mm)       | 39" (991mm)      | 72" (1829mm)     |              |
| 30" (762mm)               |                | 24" (610mm)      | 48" (1219mm)     | 66" (1676mm)     |              |
| 30" (762mm)               |                | 18" (457mm)      | 45" (1143mm)     | 66" (1676mm)     |              |
| 30" (762mm)               |                | 12" (305mm)      | 42" (1067mm)     | 66" (1676mm)     |              |
| 30" (762mm)               |                | 9" (229mm)       | 40 1/2" (1029mm) | 66" (1676mm)     |              |
| 30" (762mm)               |                | 6" (152mm)       | 39" (991mm)      | 66" (1676mm)     |              |
| 24" (610mm)               |                | 18" (457mm)      | 45" (1143mm)     | 60" (1524mm)     |              |
| 24" (610mm)               | 12" (305mm)    | 42" (1067mm)     | 60" (1524mm)     |                  |              |
| 24" (610mm)               | 9" (229mm)     | 40 1/2" (1029mm) | 60" (1524mm)     |                  |              |
| 24" (610mm)               | 6" (152mm)     | 39" (991mm)      | 60" (1524mm)     |                  |              |
| 18" (457mm)               | 12" (305mm)    | 42" (1067mm)     | 54" (1372mm)     |                  |              |
| 18" (457mm)               | 9" (229mm)     | 40 1/2" (1029mm) | 54" (1372mm)     |                  |              |
| 18" (457mm)               | 6" (152mm)     | 39" (991mm)      | 54" (1372mm)     |                  |              |
| 12" (305mm)               | 9" (229mm)     | 40 1/2" (1029mm) | 48" (1219mm)     |                  |              |
| 12" (305mm)               | 6" (152mm)     | 39" (991mm)      | 48" (1219mm)     |                  |              |
| 9" (229mm)                | 6" (152mm)     | 39" (991mm)      | 45" (1143mm)     |                  |              |

Note: Nominal 9" rung spacing maintained through centerline of all fittings.

### Ordering Information:



See Page 98  
for Electrical  
Grounding Chart

## Horizontal Cross [FC]

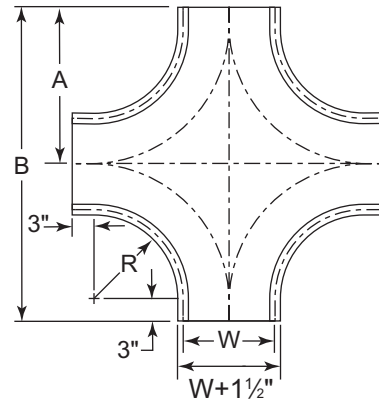
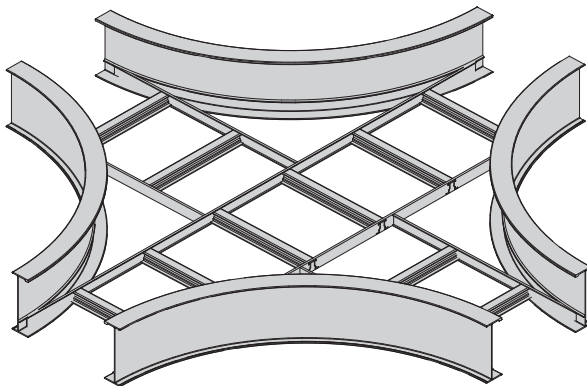

| Radius - R            | Width - W   | "A" Dimension    | "B" Dimension |
|-----------------------|-------------|------------------|---------------|
| <b>12"</b><br>(305mm) | 6" (152mm)  | 18" (457mm)      | 36" (914mm)   |
|                       | 9" (229mm)  | 19 1/2" (495mm)  | 39" (991mm)   |
|                       | 12" (305mm) | 21" (533mm)      | 42" (1067mm)  |
|                       | 18" (457mm) | 24" (610mm)      | 48" (1219mm)  |
|                       | 24" (610mm) | 27" (686mm)      | 54" (1372mm)  |
|                       | 30" (762mm) | 30" (762mm)      | 60" (1524mm)  |
|                       | 36" (914mm) | 33" (838mm)      | 66" (1676mm)  |
| <b>24"</b><br>(610mm) | 6" (152mm)  | 30" (762mm)      | 60" (1524mm)  |
|                       | 9" (229mm)  | 31 1/2" (800mm)  | 63" (1600mm)  |
|                       | 12" (305mm) | 33" (838mm)      | 66" (1676mm)  |
|                       | 18" (457mm) | 36" (914mm)      | 72" (1829mm)  |
|                       | 24" (610mm) | 39" (991mm)      | 78" (1981mm)  |
|                       | 30" (762mm) | 42" (1067mm)     | 84" (2134mm)  |
|                       | 36" (914mm) | 45" (1143mm)     | 90" (2286mm)  |
| <b>36"</b><br>(914mm) | 6" (152mm)  | 42" (1067mm)     | 84" (2134mm)  |
|                       | 9" (229mm)  | 43 1/2" (1105mm) | 87" (2210mm)  |
|                       | 12" (305mm) | 45" (1143mm)     | 90" (2286mm)  |
|                       | 18" (457mm) | 48" (1219mm)     | 96" (2438mm)  |
|                       | 24" (610mm) | 51" (1295mm)     | 102" (2591mm) |
|                       | 30" (762mm) | 54" (1372mm)     | 108" (2743mm) |
|                       | 36" (914mm) | 57" (1448mm)     | 114" (2896mm) |

EXAMPLE: H4A-12FC-12

**Note:** Nominal 9" rung spacing maintained through centerline of all fittings.

### Ordering Information:

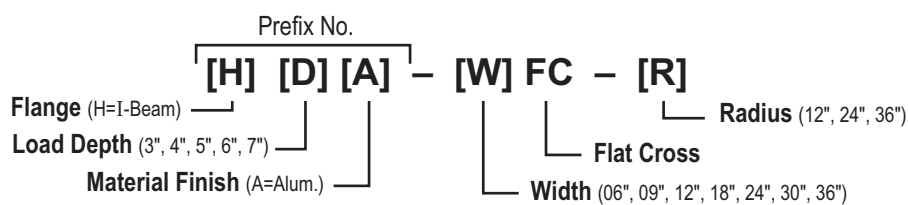

See Page 98  
for Electrical  
Grounding Chart

## Horizontal Tapped Cross [TC]

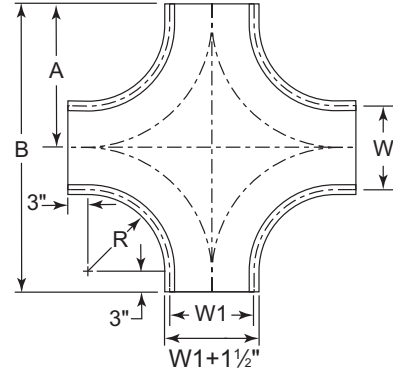
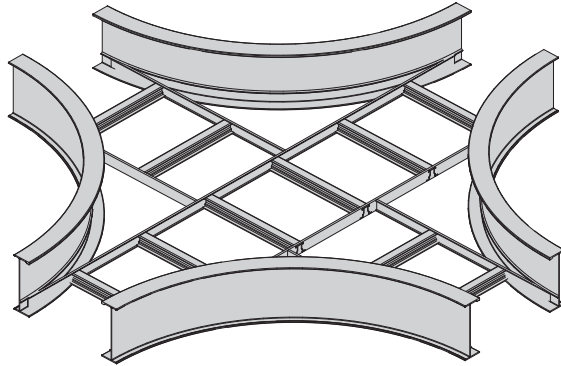

| R<br>Radius    | W<br>Width  | W1<br>Width     | "A"<br>Dimension | "C"<br>Dimension |
|----------------|-------------|-----------------|------------------|------------------|
| 12"<br>(305mm) | 36" (914mm) | 30" (762mm)     | 27" (686mm)      | 60" (1524mm)     |
|                | 36" (914mm) | 24" (610mm)     | 24" (610mm)      | 60" (1524mm)     |
|                | 36" (914mm) | 18" (457mm)     | 21" (533mm)      | 60" (1524mm)     |
|                | 36" (914mm) | 12" (305mm)     | 18" (457mm)      | 60" (1524mm)     |
|                | 36" (914mm) | 9" (229mm)      | 16 1/2" (419mm)  | 60" (1524mm)     |
|                | 36" (914mm) | 6" (152mm)      | 15" (381mm)      | 60" (1524mm)     |
|                | 30" (762mm) | 24" (610mm)     | 24" (610mm)      | 54" (1372mm)     |
|                | 30" (762mm) | 18" (457mm)     | 21" (533mm)      | 54" (1372mm)     |
|                | 30" (762mm) | 12" (305mm)     | 18" (457mm)      | 54" (1372mm)     |
|                | 30" (762mm) | 9" (229mm)      | 16 1/2" (419mm)  | 54" (1372mm)     |
|                | 30" (762mm) | 6" (152mm)      | 15" (381mm)      | 54" (1372mm)     |
|                | 24" (610mm) | 18" (457mm)     | 21" (533mm)      | 48" (1219mm)     |
| 24" (610mm)    | 12" (305mm) | 18" (457mm)     | 48" (1219mm)     |                  |
| 24" (610mm)    | 9" (229mm)  | 16 1/2" (419mm) | 48" (1219mm)     |                  |
| 24" (610mm)    | 6" (152mm)  | 15" (381mm)     | 48" (1219mm)     |                  |
| 18" (457mm)    | 12" (305mm) | 18" (457mm)     | 42" (1067mm)     |                  |
| 18" (457mm)    | 9" (229mm)  | 16 1/2" (419mm) | 42" (1067mm)     |                  |
| 18" (457mm)    | 6" (152mm)  | 15" (381mm)     | 42" (1067mm)     |                  |
| 12" (305mm)    | 9" (229mm)  | 16 1/2" (419mm) | 36" (914mm)      |                  |
| 12" (305mm)    | 6" (152mm)  | 15" (381mm)     | 36" (914mm)      |                  |
| 9" (229mm)     | 6" (152mm)  | 15" (381mm)     | 33" (838mm)      |                  |
| 24"<br>(610mm) | 36" (914mm) | 30" (762mm)     | 39" (991mm)      | 84" (2134mm)     |
|                | 36" (914mm) | 24" (610mm)     | 36" (914mm)      | 84" (2134mm)     |
|                | 36" (914mm) | 18" (457mm)     | 33" (838mm)      | 84" (2134mm)     |
|                | 36" (914mm) | 12" (305mm)     | 30" (762mm)      | 84" (2134mm)     |
|                | 36" (914mm) | 9" (229mm)      | 28 1/2" (724mm)  | 84" (2134mm)     |
|                | 36" (914mm) | 6" (152mm)      | 27" (686mm)      | 84" (2134mm)     |
|                | 30" (762mm) | 24" (610mm)     | 36" (914mm)      | 78" (1981mm)     |
|                | 30" (762mm) | 18" (457mm)     | 33" (838mm)      | 78" (1981mm)     |
|                | 30" (762mm) | 12" (305mm)     | 30" (762mm)      | 78" (1981mm)     |
|                | 30" (762mm) | 9" (229mm)      | 28 1/2" (724mm)  | 78" (1981mm)     |
|                | 30" (762mm) | 6" (152mm)      | 27" (686mm)      | 78" (1981mm)     |

| R<br>Radius               | W<br>Width     | W1<br>Width      | "A"<br>Dimension | "C"<br>Dimension |               |
|---------------------------|----------------|------------------|------------------|------------------|---------------|
| 24"<br>(610mm)<br>(Cont.) | 24" (610mm)    | 18" (457mm)      | 33" (838mm)      | 72" (1829mm)     |               |
|                           | 24" (610mm)    | 12" (305mm)      | 30" (762mm)      | 72" (1829mm)     |               |
|                           | 24" (610mm)    | 9" (229mm)       | 28 1/2" (724mm)  | 72" (1829mm)     |               |
|                           | 24" (610mm)    | 6" (152mm)       | 27" (686mm)      | 72" (1829mm)     |               |
|                           | 18" (457mm)    | 12" (305mm)      | 30" (762mm)      | 66" (1676mm)     |               |
|                           | 18" (457mm)    | 9" (229mm)       | 28 1/2" (724mm)  | 66" (1676mm)     |               |
|                           | 18" (457mm)    | 6" (152mm)       | 27" (686mm)      | 66" (1676mm)     |               |
|                           | 12" (305mm)    | 9" (229mm)       | 28 1/2" (724mm)  | 60" (1524mm)     |               |
|                           | 12" (305mm)    | 6" (152mm)       | 27" (686mm)      | 60" (1524mm)     |               |
|                           | 9" (229mm)     | 6" (152mm)       | 27" (686mm)      | 57" (1448mm)     |               |
|                           | 36"<br>(914mm) | 36" (914mm)      | 30" (762mm)      | 51" (1295mm)     | 108" (2743mm) |
|                           |                | 36" (914mm)      | 24" (610mm)      | 48" (1219mm)     | 108" (2743mm) |
| 36" (914mm)               |                | 18" (457mm)      | 45" (1143mm)     | 108" (2743mm)    |               |
| 36" (914mm)               |                | 12" (305mm)      | 42" (1067mm)     | 108" (2743mm)    |               |
| 36" (914mm)               |                | 9" (229mm)       | 40 1/2" (1029mm) | 108" (2743mm)    |               |
| 36" (914mm)               |                | 6" (152mm)       | 39" (991mm)      | 108" (2743mm)    |               |
| 30" (762mm)               |                | 24" (610mm)      | 48" (1219mm)     | 102" (2591mm)    |               |
| 30" (762mm)               |                | 18" (457mm)      | 45" (1143mm)     | 102" (2591mm)    |               |
| 30" (762mm)               |                | 12" (305mm)      | 42" (1067mm)     | 102" (2591mm)    |               |
| 30" (762mm)               |                | 9" (229mm)       | 40 1/2" (1029mm) | 102" (2591mm)    |               |
| 30" (762mm)               |                | 6" (152mm)       | 39" (991mm)      | 102" (2591mm)    |               |
| 24" (610mm)               |                | 18" (457mm)      | 45" (1143mm)     | 96" (2438mm)     |               |
| 24" (610mm)               | 12" (305mm)    | 42" (1067mm)     | 96" (2438mm)     |                  |               |
| 24" (610mm)               | 9" (229mm)     | 40 1/2" (1029mm) | 96" (2438mm)     |                  |               |
| 24" (610mm)               | 6" (152mm)     | 39" (991mm)      | 96" (2438mm)     |                  |               |
| 18" (457mm)               | 12" (305mm)    | 42" (1067mm)     | 90" (2286mm)     |                  |               |
| 18" (457mm)               | 9" (229mm)     | 40 1/2" (1029mm) | 90" (2286mm)     |                  |               |
| 18" (457mm)               | 6" (152mm)     | 39" (991mm)      | 90" (2286mm)     |                  |               |
| 12" (305mm)               | 9" (229mm)     | 40 1/2" (1029mm) | 84" (2134mm)     |                  |               |
| 12" (305mm)               | 6" (152mm)     | 39" (991mm)      | 84" (2134mm)     |                  |               |
| 9" (229mm)                | 6" (152mm)     | 39" (991mm)      | 81" (2057mm)     |                  |               |

Note: Nominal 9" rung spacing maintained through centerline of all fittings.

### Ordering Information:



See Page 98  
for Electrical  
Grounding Chart

# I-BEAM CABLE TRAY SYSTEM

## Left Hand [LH] & Right Hand [RH] Reducer

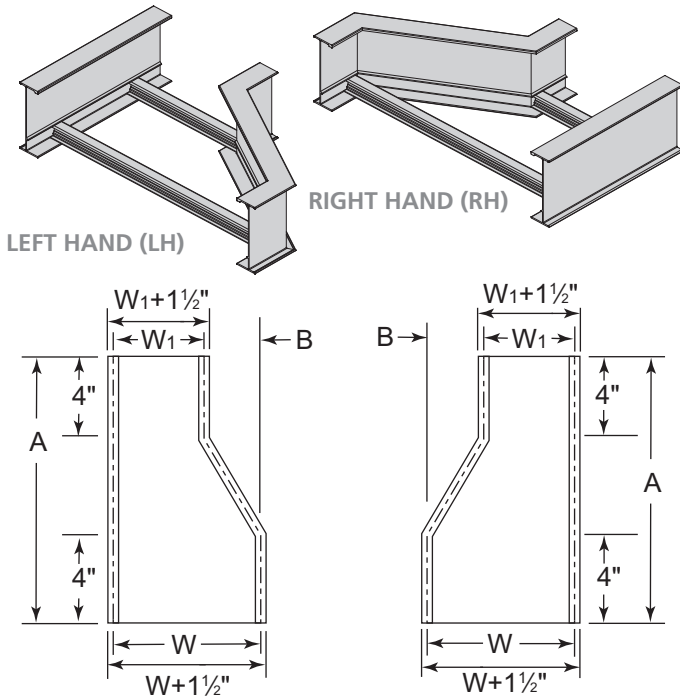

| W                  | W1          | "A" Dimension     | "B" Dimension |
|--------------------|-------------|-------------------|---------------|
| <b>9" (229mm)</b>  | 6" (152mm)  | 9 3/4" (248mm)    | 3" (76mm)     |
| <b>12" (305mm)</b> | 6" (152mm)  | 11 7/16" (291mm)  | 6" (152mm)    |
|                    | 9" (229mm)  | 9 3/4" (248mm)    | 3" (76mm)     |
| <b>18" (457mm)</b> | 6" (152mm)  | 14 15/16" (379mm) | 12" (305mm)   |
|                    | 9" (229mm)  | 13 3/16" (335mm)  | 9" (229mm)    |
|                    | 12" (305mm) | 11 7/16" (291mm)  | 6" (152mm)    |
| <b>24" (610mm)</b> | 6" (152mm)  | 18 3/8" (467mm)   | 18" (457mm)   |
|                    | 9" (229mm)  | 16 11/16" (424mm) | 15" (381mm)   |
|                    | 12" (305mm) | 14 15/16" (379mm) | 12" (305mm)   |
|                    | 18" (457mm) | 11 7/16" (291mm)  | 6" (152mm)    |
| <b>30" (762mm)</b> | 6" (152mm)  | 21 7/8" (556mm)   | 24" (610mm)   |
|                    | 9" (229mm)  | 20 1/8" (511mm)   | 21" (533mm)   |
|                    | 12" (305mm) | 18 3/8" (467mm)   | 18" (457mm)   |
|                    | 18" (457mm) | 14 15/16" (379mm) | 12" (305mm)   |
|                    | 24" (610mm) | 11 7/16" (291mm)  | 6" (152mm)    |
| <b>36" (914mm)</b> | 6" (152mm)  | 25 5/16" (643mm)  | 30" (762mm)   |
|                    | 9" (229mm)  | 23 9/16" (598mm)  | 27" (686mm)   |
|                    | 12" (305mm) | 21 7/8" (556mm)   | 24" (610mm)   |
|                    | 18" (457mm) | 18 3/8" (467mm)   | 18" (457mm)   |
|                    | 24" (610mm) | 14 15/16" (379mm) | 12" (305mm)   |
|                    | 30" (762mm) | 11 7/16" (291mm)  | 6" (152mm)    |

EXAMPLE: H4A-12LH-06

Note: Nominal 9" rung spacing maintained through centerline of all fittings.

## Straight Reducer [ST]

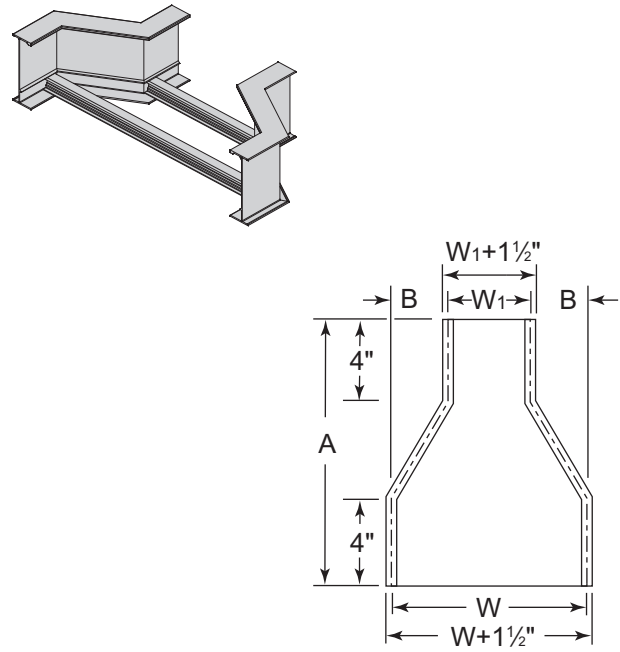

| W                  | W1          | "A" Dimension     | "B" Dimension   |
|--------------------|-------------|-------------------|-----------------|
| <b>9" (229mm)</b>  | 6" (152mm)  | 8 7/8" (225mm)    | 1 1/2" (38mm)   |
| <b>12" (305mm)</b> | 6" (152mm)  | 9 3/4" (248mm)    | 3" (76mm)       |
|                    | 9" (229mm)  | 8 7/8" (225mm)    | 1 1/2" (38mm)   |
| <b>18" (457mm)</b> | 6" (152mm)  | 11 7/16" (291mm)  | 6" (152mm)      |
|                    | 9" (229mm)  | 10 5/8" (270mm)   | 4 1/2" (114mm)  |
|                    | 12" (305mm) | 9 3/4" (248mm)    | 3" (76mm)       |
| <b>24" (610mm)</b> | 6" (152mm)  | 13 3/16" (335mm)  | 9" (229mm)      |
|                    | 9" (229mm)  | 12 5/16" (313mm)  | 7 1/2" (191mm)  |
|                    | 12" (305mm) | 11 7/16" (291mm)  | 6" (152mm)      |
|                    | 18" (457mm) | 9 3/4" (248mm)    | 3" (76mm)       |
| <b>30" (762mm)</b> | 6" (152mm)  | 14 15/16" (379mm) | 12" (305mm)     |
|                    | 9" (229mm)  | 14 1/16" (357mm)  | 10 1/2" (267mm) |
|                    | 12" (305mm) | 13 3/16" (335mm)  | 9" (229mm)      |
|                    | 18" (457mm) | 11 7/16" (291mm)  | 6" (152mm)      |
|                    | 24" (610mm) | 9 3/4" (248mm)    | 3" (76mm)       |
| <b>36" (914mm)</b> | 6" (152mm)  | 16 11/16" (424mm) | 15" (381mm)     |
|                    | 9" (229mm)  | 15 13/16" (402mm) | 13 1/2" (343mm) |
|                    | 12" (305mm) | 14 15/16" (379mm) | 12" (305mm)     |
|                    | 18" (457mm) | 13 3/16" (335mm)  | 9" (229mm)      |
|                    | 24" (610mm) | 11 7/16" (291mm)  | 6" (152mm)      |
|                    | 30" (762mm) | 9 3/4" (248mm)    | 3" (76mm)       |

EXAMPLE: H4A-12ST-06

### Ordering Information:

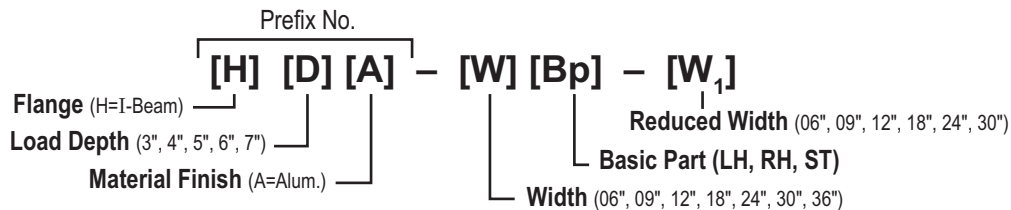

See Page 98 for Electrical Grounding Chart

## 45°"Y" Branch Left Hand [LY] & Right Hand [RY]

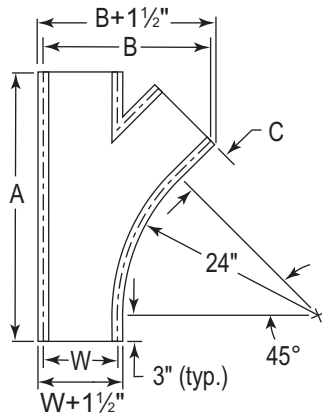
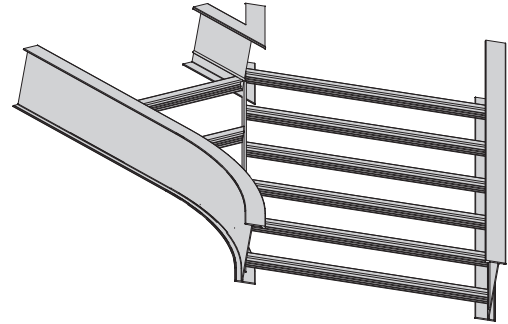
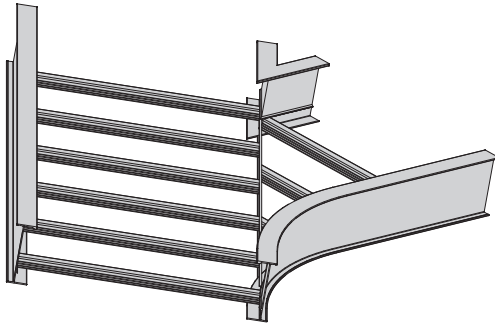

**RIGHT HAND (RY)**

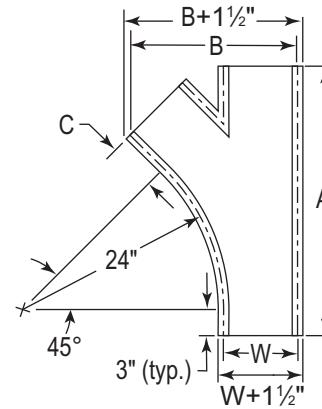

**LEFT HAND (LY)**

| W           | "A" Dimension      | "B" Dimension      | "C" Dimension    |
|-------------|--------------------|--------------------|------------------|
| 6" (152mm)  | 28 7/16" (722mm)   | 15 3/16" (386mm)   | 3 1/16" (78mm)   |
| 9" (229mm)  | 32 11/16" (830mm)  | 20 5/16" (516mm)   | 6 1/16" (154mm)  |
| 12" (305mm) | 36 15/16" (938mm)  | 25 7/16" (646mm)   | 9 1/16" (230mm)  |
| 18" (457mm) | 45 3/8" (1153mm)   | 35 13/16" (910mm)  | 15 1/16" (383mm) |
| 24" (610mm) | 53 7/8" (1368mm)   | 45 15/16" (1167mm) | 21 1/16" (535mm) |
| 30" (762mm) | 62 3/8" (1584mm)   | 56 3/16" (1427mm)  | 27 1/16" (687mm) |
| 36" (914mm) | 70 13/16" (1799mm) | 66 7/16" (1688mm)  | 33 1/16" (840mm) |

EXAMPLE: H4A-12LY

**Note:** Nominal 9" rung spacing maintained through centerline of all fittings.

**Ordering Information:**

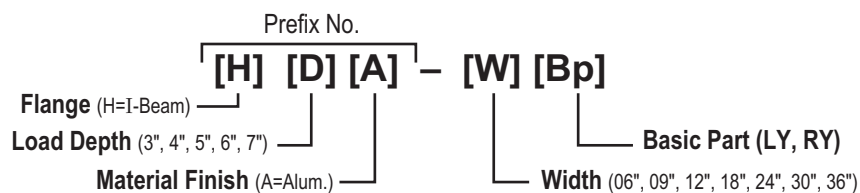

See Page 98  
for Electrical  
Grounding Chart

## 90° Vertical Elbow Outside [90] & Inside [9I]

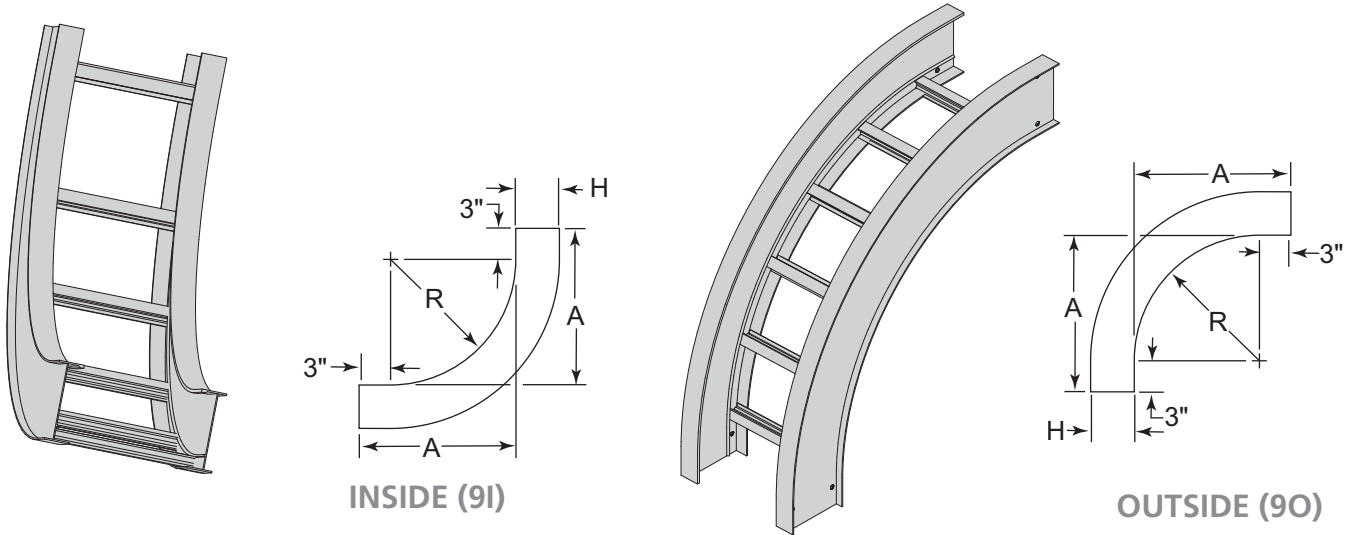

| Radius - R            | Load Depth  | "H" Dimension  | A (Outside 90) | A (Inside 9I)    |
|-----------------------|-------------|----------------|----------------|------------------|
| <b>12"</b><br>(305mm) | 3" (76mm)   | 4 1/8" (105mm) | 15" (381mm)    | 19 1/8" (486mm)  |
|                       | 4" (102mm)  | 5" (127mm)     | 15" (381mm)    | 20" (508mm)      |
|                       | 5" (127mm)  | 6 1/4" (159mm) | 15" (381mm)    | 21 1/4" (540mm)  |
|                       | 6" (152mm)  | 7 1/4" (184mm) | 15" (381mm)    | 22 1/4" (565mm)  |
|                       | 7" (179mm)  | 8" (203mm)     | 15" (381mm)    | 23" (584mm)      |
| <b>24"</b><br>(610mm) | 3" (76mm)   | 4 1/8" (105mm) | 27" (686mm)    | 31 1/8" (791mm)  |
|                       | 4" (102mm)  | 5" (127mm)     | 27" (686mm)    | 32" (813mm)      |
|                       | 5" (127mm)  | 6 1/4" (159mm) | 27" (686mm)    | 33 1/4" (845mm)  |
|                       | 6" (152mm)  | 7 1/4" (184mm) | 27" (686mm)    | 34 1/4" (870mm)  |
|                       | 7" (1579mm) | 8" (203mm)     | 27" (686mm)    | 35" (889mm)      |
| <b>36"</b><br>(914mm) | 3" (76mm)   | 4 1/8" (105mm) | 39" (991mm)    | 43 1/8" (1095mm) |
|                       | 4" (102mm)  | 5" (127mm)     | 39" (991mm)    | 44" (1118mm)     |
|                       | 5" (127mm)  | 6 1/4" (159mm) | 39" (991mm)    | 45 1/4" (1149mm) |
|                       | 6" (152mm)  | 7 1/4" (184mm) | 39" (991mm)    | 46 1/4" (1175mm) |
|                       | 7" (179mm)  | 8" (203mm)     | 39" (991mm)    | 47" (1194mm)     |

EXAMPLE: H4A-1290-12

**Note:** Nominal 9" rung spacing maintained through centerline of all fittings.

### Ordering Information:



See Page 98 for Electrical Grounding Chart

## 60° Vertical Elbow Outside [60] & Inside [6I]

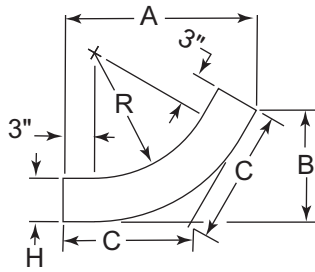
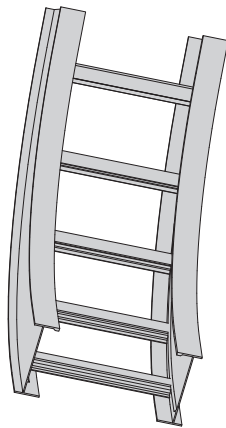

INSIDE (6I)

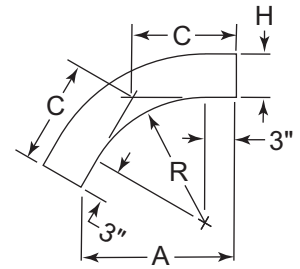
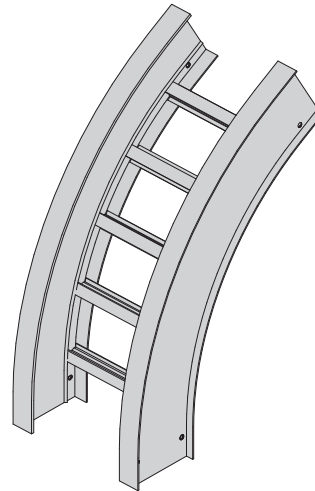

OUTSIDE (60)

| Radius<br>R           | Load<br>Depth | H              | Outside (60)      |                 |                   | Inside (6I)        |                   |                   |
|-----------------------|---------------|----------------|-------------------|-----------------|-------------------|--------------------|-------------------|-------------------|
|                       |               |                | A                 | B               | C                 | A                  | B                 | C                 |
| <b>12"</b><br>(305mm) | 3" (76mm)     | 4 1/8" (105mm) |                   |                 |                   | 18 7/16" (468mm)   | 10 11/16" (271mm) | 12 5/16" (313mm)  |
|                       | 4" (102mm)    | 5" (127mm)     |                   |                 |                   | 19 1/4" (489mm)    | 11 1/8" (283mm)   | 12 13/16" (325mm) |
|                       | 5" (127mm)    | 6 1/4" (159mm) | 14 7/8" (378mm)   | 8 5/8" (219mm)  | 9 15/16" (252mm)  | 20 5/16" (516mm)   | 11 3/4" (298mm)   | 13 9/16" (344mm)  |
|                       | 6" (152mm)    | 7 1/4" (184mm) |                   |                 |                   | 21 3/16" (538mm)   | 12 1/4" (311mm)   | 14 1/8" (359mm)   |
|                       | 7" (179mm)    | 8" (203mm)     |                   |                 |                   | 21 13/16" (554mm)  | 12 5/8" (321mm)   | 14 9/16" (370mm)  |
| <b>24"</b><br>(610mm) | 3" (76mm)     | 4 1/8" (105mm) |                   |                 |                   | 28 7/8" (733mm)    | 16 11/16" (424mm) | 19 1/4" (489mm)   |
|                       | 4" (102mm)    | 5" (127mm)     |                   |                 |                   | 29 5/8" (752mm)    | 17 1/8" (435mm)   | 19 3/4" (502mm)   |
|                       | 5" (127mm)    | 6 1/4" (159mm) | 25 5/16" (643mm)  | 14 5/8" (371mm) | 16 7/8" (429mm)   | 30 11/16" (779mm)  | 17 3/4" (451mm)   | 20 7/16" (519mm)  |
|                       | 6" (152mm)    | 7 1/4" (184mm) |                   |                 |                   | 31 9/16" (802mm)   | 18 1/4" (464mm)   | 21 1/16" (535mm)  |
|                       | 7" (179mm)    | 8" (203mm)     |                   |                 |                   | 32 3/16" (818mm)   | 18 5/8" (473mm)   | 21 1/2" (546mm)   |
| <b>36"</b><br>(914mm) | 3" (76mm)     | 4 1/8" (105mm) |                   |                 |                   | 39 1/4" (997mm)    | 22 11/16" (576mm) | 26 3/16" (665mm)  |
|                       | 4" (102mm)    | 5" (127mm)     |                   |                 |                   | 40" (1016mm)       | 23 1/8" (587mm)   | 26 11/16" (678mm) |
|                       | 5" (127mm)    | 6 1/4" (159mm) | 35 11/16" (906mm) | 20 5/8" (524mm) | 23 13/16" (605mm) | 41 1/16" (1043mm)  | 23 3/4" (603mm)   | 27 3/8" (695mm)   |
|                       | 6" (152mm)    | 7 1/4" (184mm) |                   |                 |                   | 41 15/16" (1065mm) | 24 1/4" (616mm)   | 28" (711mm)       |
|                       | 7" (179mm)    | 8" (203mm)     |                   |                 |                   | 42 5/8" (1083mm)   | 24 5/8" (625mm)   | 28 3/8" (721mm)   |

EXAMPLE: H4A-1260-12

**Note:** Nominal 9" rung spacing maintained through centerline of all fittings.

**Ordering Information:**

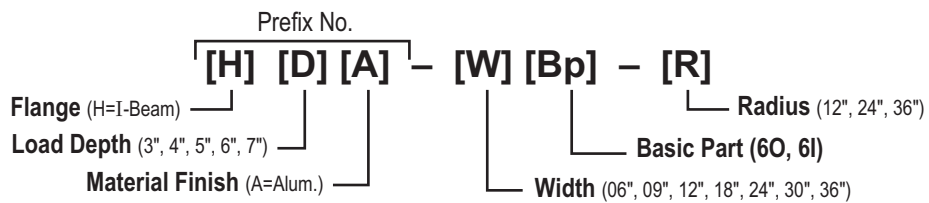

See Page 98 for Electrical Grounding Chart

# I-BEAM CABLE TRAY SYSTEM

## 45° Vertical Elbow Outside [40] & Inside [41]

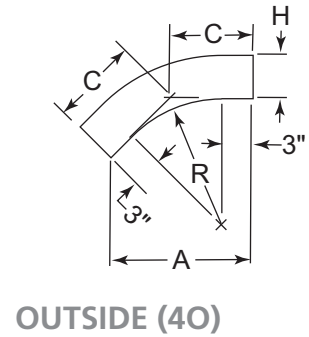
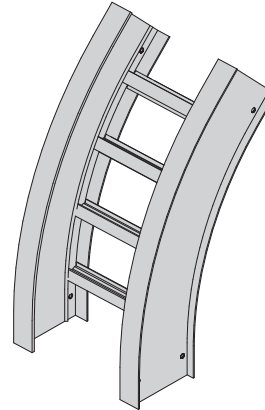
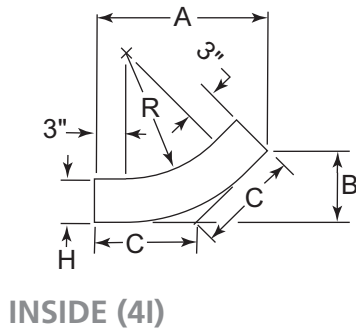
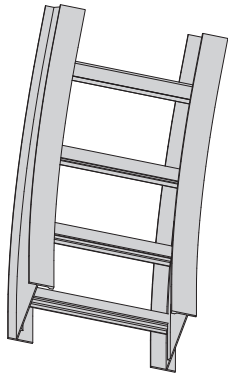

| Radius<br>R           | Load<br>Depth | H              | Outside (40)        |                      |                      | Inside (41)       |                   |                   |
|-----------------------|---------------|----------------|---------------------|----------------------|----------------------|-------------------|-------------------|-------------------|
|                       |               |                | A                   | B                    | C                    | A                 | B                 | C                 |
| <b>12"</b><br>(305mm) | 3" (76mm)     | 4 1/8" (105mm) | 13 5/8"<br>(346mm)  | 5 5/8"<br>(143mm)    | 8"<br>(203mm)        | 16 1/2" (419mm)   | 6 7/8" (175mm)    | 9 11/16" (246mm)  |
|                       | 4" (102mm)    | 5" (127mm)     |                     |                      |                      | 17 1/8" (435mm)   | 7 1/8" (181mm)    | 10 1/4" (256mm)   |
|                       | 5" (127mm)    | 6 1/4" (159mm) |                     |                      |                      | 18" (457mm)       | 7 7/16" (189mm)   | 10 9/16" (268mm)  |
|                       | 6" (152mm)    | 7 1/4" (184mm) |                     |                      |                      | 18 3/4" (476mm)   | 7 3/4" (197mm)    | 11" (279mm)       |
|                       | 7" (179mm)    | 8" (203mm)     |                     |                      |                      | 19 1/4" (489mm)   | 8" (203mm)        | 11 5/16" (287mm)  |
| <b>24"</b><br>(610mm) | 3" (76mm)     | 4 1/8" (105mm) | 22 1/16"<br>(560mm) | 9 1/8"<br>(232mm)    | 12 15/16"<br>(329mm) | 25" (635mm)       | 10 3/8" (264mm)   | 14 5/8" (371mm)   |
|                       | 4" (102mm)    | 5" (127mm)     |                     |                      |                      | 25 5/8" (651mm)   | 10 5/8" (270mm)   | 15" (381mm)       |
|                       | 5" (127mm)    | 6 1/4" (159mm) |                     |                      |                      | 26 1/2" (673mm)   | 11" (279mm)       | 15 1/2" (394mm)   |
|                       | 6" (152mm)    | 7 1/4" (184mm) |                     |                      |                      | 27 3/16" (691mm)  | 11 1/4" (286mm)   | 15 15/16" (405mm) |
|                       | 7" (179mm)    | 8" (203mm)     |                     |                      |                      | 27 3/4" (705mm)   | 11 1/2" (292mm)   | 16 1/4" (413mm)   |
| <b>36"</b><br>(914mm) | 3" (76mm)     | 4 1/8" (105mm) | 30 9/16"<br>(776mm) | 12 11/16"<br>(322mm) | 17 15/16"<br>(456mm) | 33 1/2" (851mm)   | 13 7/8" (352mm)   | 19 5/8" (498mm)   |
|                       | 4" (102mm)    | 5" (127mm)     |                     |                      |                      | 34 1/8" (867mm)   | 14 1/8" (359mm)   | 20" (508mm)       |
|                       | 5" (127mm)    | 6 1/4" (159mm) |                     |                      |                      | 35" (889mm)       | 14 1/2" (368mm)   | 20 1/2" (521mm)   |
|                       | 6" (152mm)    | 7 1/4" (184mm) |                     |                      |                      | 35 11/16" (906mm) | 14 13/16" (376mm) | 20 15/16" (532mm) |
|                       | 7" (179mm)    | 8" (203mm)     |                     |                      |                      | 36 1/4" (921mm)   | 15" (381mm)       | 21 1/4" (540mm)   |

EXAMPLE: H4A-1240-12

**Note:** Nominal 9" rung spacing maintained through centerline of all fittings.

### Ordering Information:

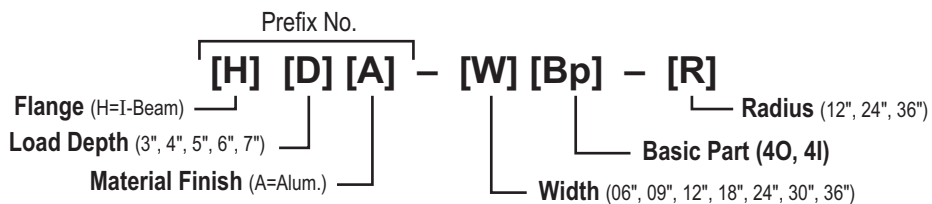

See Page 98  
for Electrical  
Grounding Chart

## 30° Vertical Elbow Outside [30] & Inside [31]

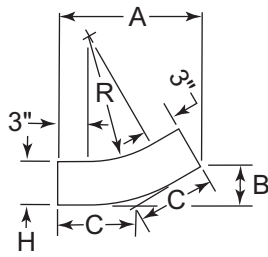
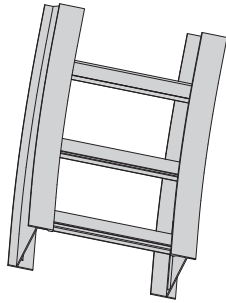

INSIDE (31)

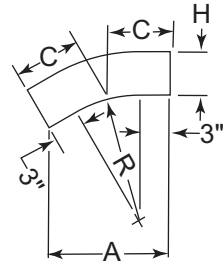
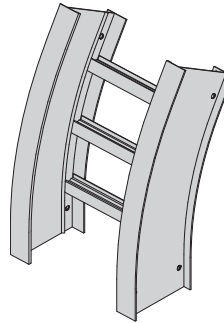

OUTSIDE (30)

| Radius<br>- R         | Load<br>Depth | H              | Outside (30)    |                  |                 | Inside (31)       |                  |                   |
|-----------------------|---------------|----------------|-----------------|------------------|-----------------|-------------------|------------------|-------------------|
|                       |               |                | A               | B                | C               | A                 | B                | C                 |
| <b>12"</b><br>(305mm) | 3" (76mm)     | 4 1/8" (105mm) |                 |                  |                 | 13 11/16" (348mm) | 3 11/16" (94mm)  | 7 5/16" (186mm)   |
|                       | 4" (102mm)    | 5" (127mm)     |                 |                  |                 | 14 1/8" (359mm)   | 3 3/4" (95mm)    | 7 9/16" (192mm)   |
|                       | 5" (127mm)    | 6 1/4" (159mm) | 11 5/8" (295mm) | 3 1/8" (79mm)    | 6 3/16" (157mm) | 14 3/4" (375mm)   | 3 15/16" (100mm) | 7 7/8" (200mm)    |
|                       | 6" (152mm)    | 7 1/4" (184mm) |                 |                  |                 | 15 1/4" (387mm)   | 4 1/16" (103mm)  | 8 3/8" (208mm)    |
|                       | 7" (179mm)    | 8" (203mm)     |                 |                  |                 | 15 5/8" (397mm)   | 4 3/16" (106mm)  | 8 3/8" (213mm)    |
| <b>24"</b><br>(610mm) | 3" (76mm)     | 4 1/8" (105mm) |                 |                  |                 | 19 11/16" (500mm) | 5 1/4" (133mm)   | 10 9/16" (268mm)  |
|                       | 4" (102mm)    | 5" (127mm)     |                 |                  |                 | 20 1/8" (511mm)   | 5 3/8" (137mm)   | 10 3/4" (273mm)   |
|                       | 5" (127mm)    | 6 1/4" (159mm) | 17 5/8" (448mm) | 4 11/16" (119mm) | 9 7/16" (240mm) | 20 3/4" (527mm)   | 5 9/16" (141mm)  | 11 1/8" (283mm)   |
|                       | 6" (152mm)    | 7 1/4" (184mm) |                 |                  |                 | 21 1/4" (540mm)   | 5 11/16" (144mm) | 11 3/8" (289mm)   |
|                       | 7" (179mm)    | 8" (203mm)     |                 |                  |                 | 21 5/8" (549mm)   | 5 13/16" (148mm) | 11 9/16" (294mm)  |
| <b>36"</b><br>(914mm) | 3" (76mm)     | 4 1/8" (105mm) |                 |                  |                 | 25 11/16" (652mm) | 6 7/8" (175mm)   | 13 3/4" (349mm)   |
|                       | 4" (102mm)    | 5" (127mm)     |                 |                  |                 | 26 1/8" (664mm)   | 7" (178mm)       | 14" (356mm)       |
|                       | 5" (127mm)    | 6 1/4" (159mm) | 23 5/8" (600mm) | 6 5/16" (160mm)  | 12 5/8" (321mm) | 26 3/4" (679mm)   | 7 3/16" (183mm)  | 14 5/16" (364mm)  |
|                       | 6" (152mm)    | 7 1/4" (184mm) |                 |                  |                 | 27 1/4" (692mm)   | 7 5/16" (186mm)  | 14 9/16" (376mm)  |
|                       | 7" (179mm)    | 8" (203mm)     |                 |                  |                 | 27 5/8" (702mm)   | 7 3/8" (187mm)   | 14 13/16" (370mm) |

EXAMPLE: H4A-1231-12

**Note:** Nominal 9" rung spacing maintained through centerline of all fittings.

### Ordering Information:

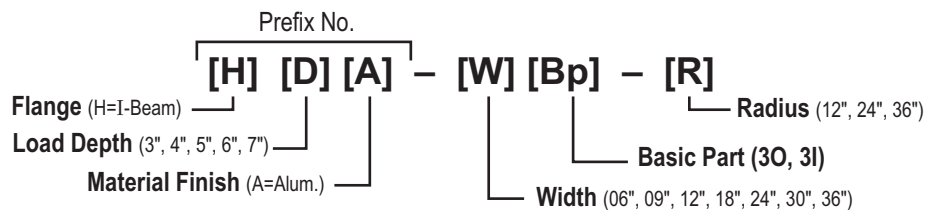

See Page 98  
for Electrical  
Grounding Chart

## 90° Vertical Cable Support Elbow [SR]

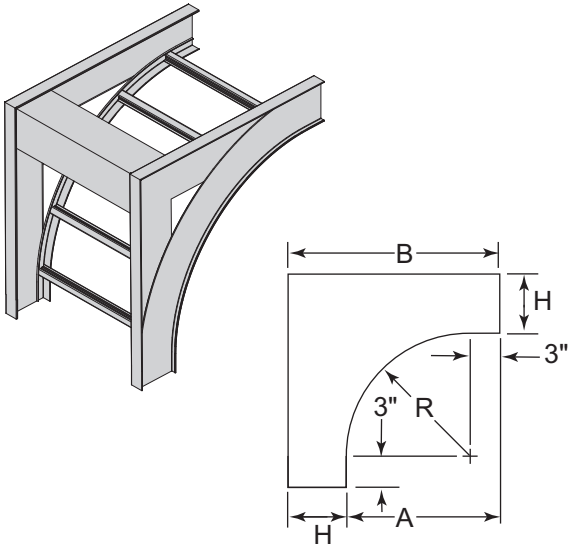

| Radius - R            | Load Depth | H              | A              | B                |
|-----------------------|------------|----------------|----------------|------------------|
| <b>12"</b><br>(305mm) | 3" (76mm)  | 4 1/8" (105mm) | 15"<br>(381mm) | 19 1/8" (486mm)  |
|                       | 4" (102mm) | 5" (127mm)     |                | 20" (508mm)      |
|                       | 5" (127mm) | 6 1/4" (159mm) |                | 21 1/4" (540mm)  |
|                       | 6" (152mm) | 7 1/4" (184mm) |                | 22 1/4" (565mm)  |
|                       | 7" (179mm) | 8" (203mm)     |                | 23" (584mm)      |
| <b>24"</b><br>(610mm) | 3" (76mm)  | 4 1/8" (105mm) | 27"<br>(686mm) | 21 1/8" (537mm)  |
|                       | 4" (102mm) | 5" (127mm)     |                | 32" (813mm)      |
|                       | 5" (127mm) | 6 1/4" (159mm) |                | 33 1/4" (845mm)  |
|                       | 6" (152mm) | 7 1/4" (184mm) |                | 34 1/4" (870mm)  |
|                       | 7" (179mm) | 8" (203mm)     |                | 35" (889mm)      |
| <b>36"</b><br>(914mm) | 3" (76mm)  | 4 1/8" (105mm) | 39"<br>(991mm) | 43 1/8" (1095mm) |
|                       | 4" (102mm) | 5" (127mm)     |                | 44" (1118mm)     |
|                       | 5" (127mm) | 6 1/4" (159mm) |                | 45 1/4" (1149mm) |
|                       | 6" (152mm) | 7 1/4" (184mm) |                | 46 1/4" (1175mm) |
|                       | 7" (179mm) | 8" (203mm)     |                | 47" (1194mm)     |

EXAMPLE: H4A-12SR-12

## Vertical Tee Down [VT] & Up [OT]

### VERTICAL TEE - DOWN (VT)

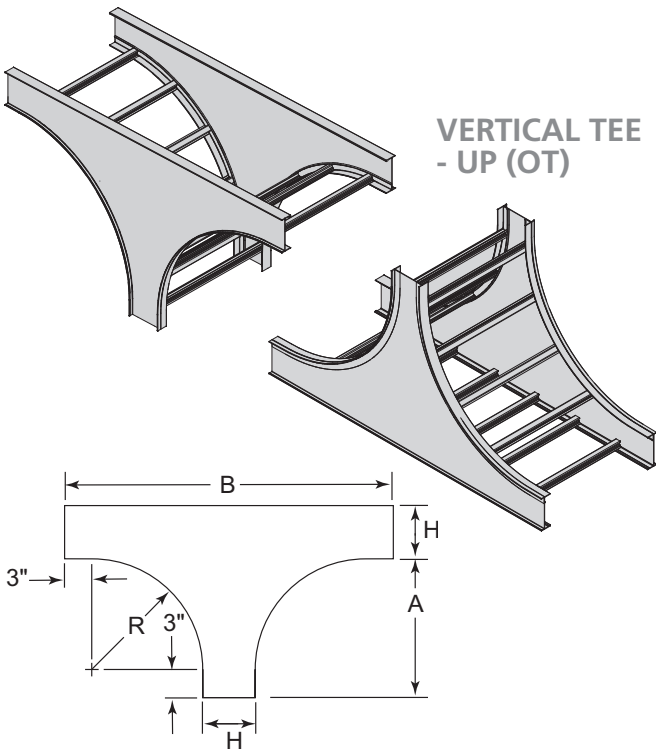

| Radius - R            | Load Depth | H              | A              | B                |
|-----------------------|------------|----------------|----------------|------------------|
| <b>12"</b><br>(305mm) | 3" (76mm)  | 4 1/8" (105mm) | 15"<br>(381mm) | 34 1/8" (867mm)  |
|                       | 4" (102mm) | 5" (127mm)     |                | 35" (889mm)      |
|                       | 5" (127mm) | 6 1/4" (159mm) |                | 36 1/4" (921mm)  |
|                       | 6" (152mm) | 7 1/4" (184mm) |                | 37 1/4" (946mm)  |
|                       | 7" (179mm) | 8" (203mm)     |                | 38" (965mm)      |
| <b>24"</b><br>(610mm) | 3" (76mm)  | 4 1/8" (105mm) | 27"<br>(686mm) | 58 1/8" (1476mm) |
|                       | 4" (102mm) | 5" (127mm)     |                | 59" (1499mm)     |
|                       | 5" (127mm) | 6 1/4" (159mm) |                | 60 1/4" (1530mm) |
|                       | 6" (152mm) | 7 1/4" (184mm) |                | 61 1/4" (1556mm) |
|                       | 7" (179mm) | 8" (203mm)     |                | 62" (1575mm)     |
| <b>36"</b><br>(914mm) | 3" (76mm)  | 4 1/8" (105mm) | 39"<br>(991mm) | 82 1/8" (2086mm) |
|                       | 4" (102mm) | 5" (127mm)     |                | 83" (2108mm)     |
|                       | 5" (127mm) | 6 1/4" (159mm) |                | 84 1/4" (2140mm) |
|                       | 6" (152mm) | 7 1/4" (184mm) |                | 85 1/4" (2165mm) |
|                       | 7" (179mm) | 8" (203mm)     |                | 86" (2184mm)     |

EXAMPLE: H4A-12VT-12

Note: Nominal 9" rung spacing maintained through centerline of all fittings.

### Ordering Information:

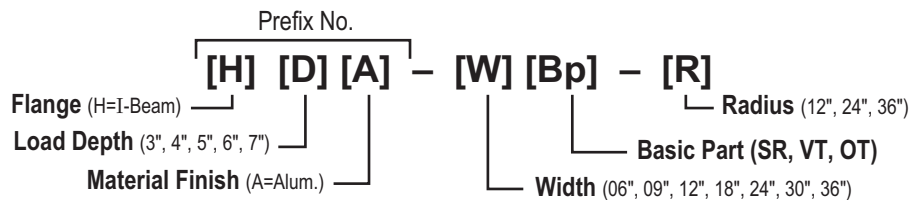

See Page 98  
for Electrical  
Grounding Chart

## CONNECTOR PLATES

### Tray Connectors

#### Catalog Number (Aluminum)

| Part | Load Depth | Basic No. |
|------|------------|-----------|
| H3A  | 3"         | -02RC     |
| H4A  | 4"         | -02CE     |
| H5A  | 5"         | -02CV     |
| H6A  | 6"         | -02CH     |
| H7A  | 7"         | -02CA     |

**EXAMPLE:** H3A -02RC for I-Beam flange, 3" load depth, aluminum, universal curvilinear connector.

**NOTE:** Hole patterns match corresponding tray. Three-hole pattern illustrated.

### Universal Connector [RC]

**Note:** Sold in pairs

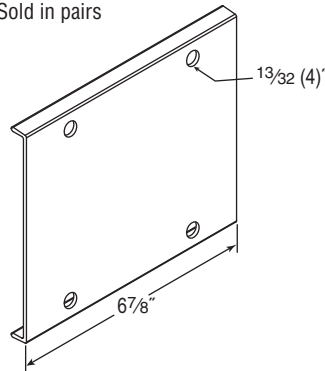

11 Gage Steel, 0.125" Aluminum  
3/8"-16 spline bolts & flange nuts furnished.

### Expansion Connector [CE]

**Note:** Sold in pairs

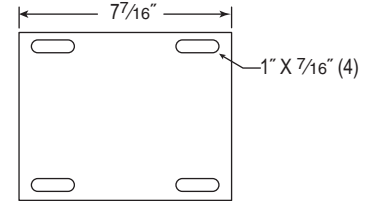

11 Gage Steel, 0.125" Aluminum  
3/8"-16 cap screws & Nylok nuts furnished and 3/8"-16 spline bolts & flange nuts furnished.

**NOTE:** Bonding Jumpers are required and are sold separately.

### Mid-Span Splice Plate [RC]

3/8" - Aluminum

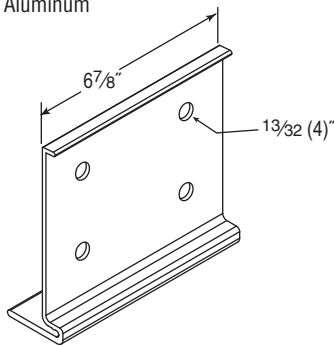

#### Catalog Number

| Part         | Use With System |
|--------------|-----------------|
| H5A-02RC-MID | 7H5A, 9H5A      |
| H6A-02RC-MID | 7H6A, 9H6A      |

### Horizontal Adjustable Connector [CH]

**Note:** Sold in pairs – inner & outer

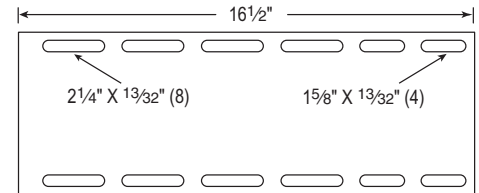
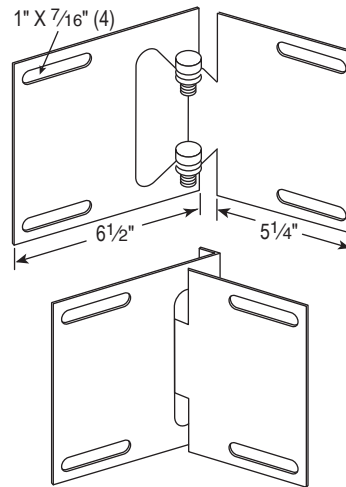

0.125" Aluminum

Horizontal Adjustable Splice Plate to be used with HCH hinge

3/8"-16 spline bolts and flange nuts furnished.

### Mid-Span Splice Plate [RC]

Catalog Number: H7A-02RC-MID

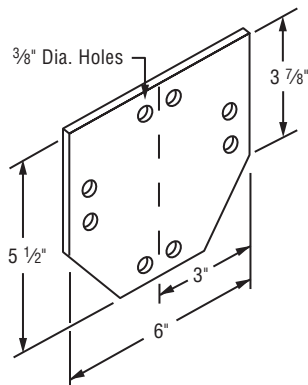

3/8" - Aluminum

For use with 11H7A Systems.

### Reducing Connector [CO]

**Note:** Not sold in pairs

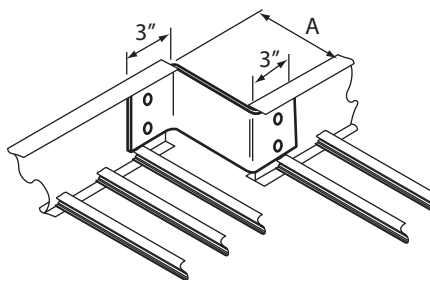

0.125" Aluminum

For offset reductions – use 1 of above with standard connector plate.

For straight reductions– use 2 (of 1/2 reduction dim.).

3/8"-16 spline bolts and flange nuts furnished.

#### Catalog Number (Aluminum)

| Part | Load Depth | Basic Number | "A" Dimension   |
|------|------------|--------------|-----------------|
| H3A  | 3"         | -30CO        | 30" (762mm)     |
| H4A  | 4"         | -27CO        | 27" (686mm)     |
| H5A  | 5"         | -24CO        | 24" (610mm)     |
| H6A  | 6"         | -21CO        | 21" (533mm)     |
| H7A  | 7"         | -18CO        | 18" (457mm)     |
|      |            | -15CO        | 15" (381mm)     |
|      |            | -13CO        | 13 1/2" (343mm) |
|      |            | -12CO        | 12" (305mm)     |
|      |            | -10CO        | 10 1/2" (267mm) |
|      |            | -09CO        | 9" (229mm)      |
|      |            | -07CO        | 7 1/2" (191mm)  |
|      |            | -06CO        | 6" (152mm)      |
|      |            | -04CO        | 4 1/2" (114mm)  |
|      |            | -03CO        | 3" (76mm)       |
|      |            | -01CO        | 1 1/2" (38mm)   |

**EXAMPLE:** H3A-03CO for I-Beam flange, 3" load depth, aluminum, 3" Reducer Connector. Typical Use: 9" to 6", or use 2 for 12" to 6", etc.

# I-BEAM CABLE TRAY SYSTEM



## CONNECTOR PLATES

### Vertical Adjustable Connector [CV]

11 Gage Steel, 0.125" Aluminum  
 $\frac{3}{8}$ "-16 spline bolts & flange nuts furnished.

**Note:** Sold in pairs

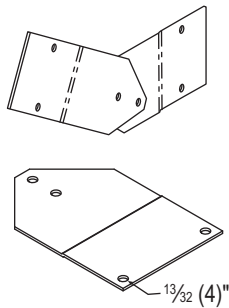

### Heavy Duty Hold Down Bracket [7-HDHDB]

2 -  $\frac{3}{8}$ " Holes & 2 -  $\frac{1}{2}$ " Holes.

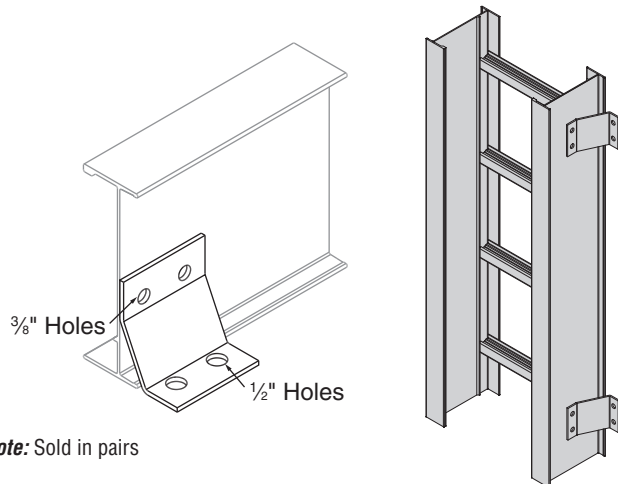

**Note:** Sold in pairs

### Vertical Adj. Branch Pivot Connector [BPC]

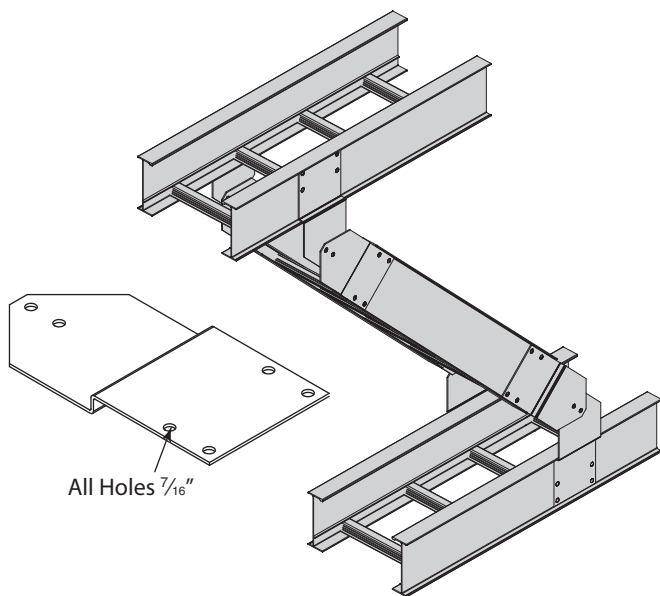

### Cross Connection Bracket [CCB]

4 -  $\frac{3}{8}$ " Holes

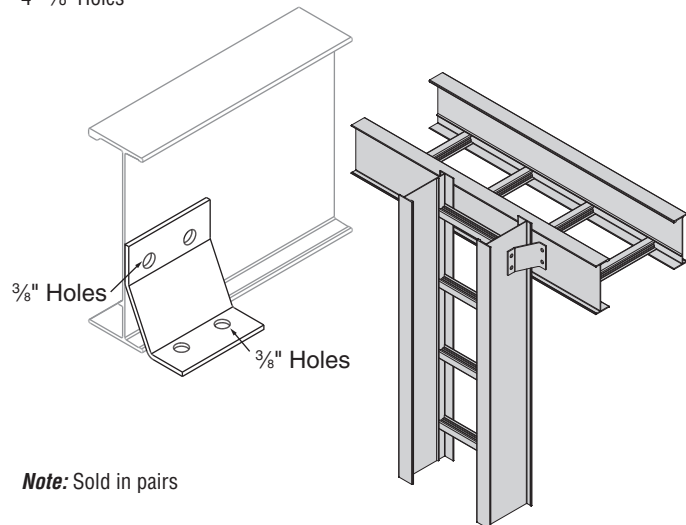

**Note:** Sold in pairs

### Vertical Hanger Splice Plate [VH]

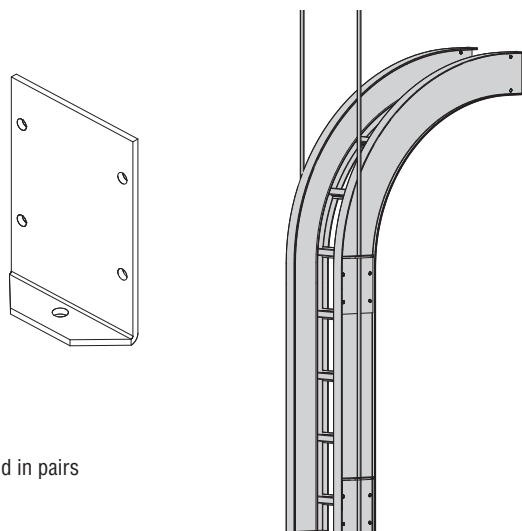

**Note:** Sold in pairs

| Catalog No. | For Use With Cope System Number |
|-------------|---------------------------------|
| H-9043-412  | 5H3A                            |
| H-9043-500  | 5H4A                            |
| H-9043-619  | 7H5A                            |
| H-9043-724  | 7H6A                            |
| H-9043-624  | 9H5A                            |
| H-9043-724  | 9H6A                            |
| H-9043-800  | 11H7A                           |

I-Beam Supports can be bolted anywhere along the straight runs. They can be bolted directly onto the coupler plates at splices of straight runs and riser fittings, or they can be bolted at any place in the run by field-drilling side rails. I-Beam supports are used with either  $\frac{3}{8}$ " or  $\frac{1}{2}$ " hanger rods. Finish is aluminum.

### Combination Hold-Down Clamp & Expansion Guide [9131A]

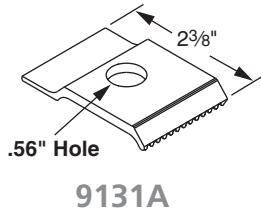

9131A

| Catalog No. | Material                 |
|-------------|--------------------------|
| 9131A       | Aluminum                 |
| 9131L       | Stainless Steel Type 316 |

Hardware purchased separately to suit support system.



PS NS

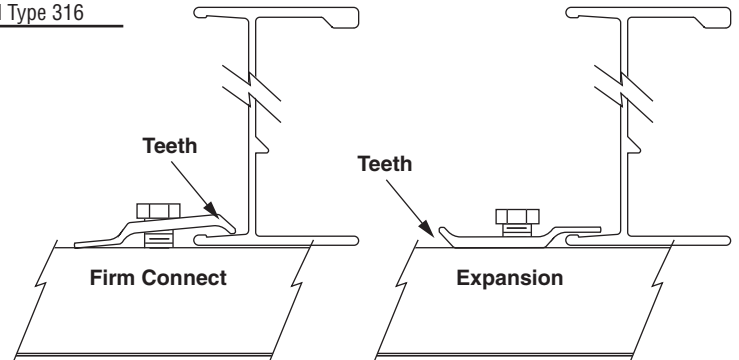

Catalog No. 9131A-HDW (Complete Hardware Kit)

Hardware list:

- (2) 9131A Combination hold-down clamp & expansion guides
- (2) PS 6024 - 1/2" - 13 x 1 1/4" Cap Screw
- (2) PS 209 - 1/2" Flat Washer
- (2) PS NS - Clamping Nut (Strut Nut)

### Combination Hold-Down / Expansion Guide [9053]

Universal Guide: for either side of ladder. Use when tray is mounted on I-beams or channels. No drilling required.

**Note:** Use set screws for firm hold down

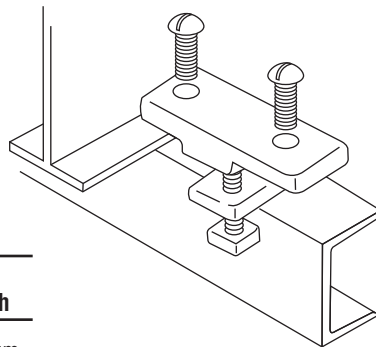

| Type              | Catalog No. | Finish     |
|-------------------|-------------|------------|
| Combination Guide | 8-9053      | Cast Alum. |

**Note:** Electroplated set screws included

### Isolation Pad [9131-IP]

The Isolation pad provides protection from galvanic corrosion when Aluminum tray is mounted on steel supports.

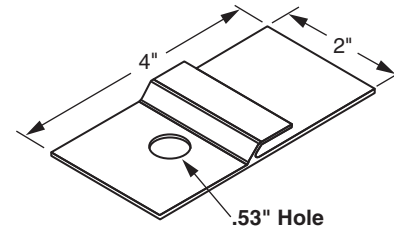

**Note:** For use with the 9131A-HDW shown above.

Hardware purchased separately

### Box Splice Plate [CA]

**Note:** Sold in pairs

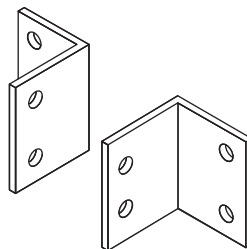

Use to attach the end of a cable tray to a distribution box or control panel.

| Catalog Number |            |           |           |
|----------------|------------|-----------|-----------|
| Part           | Load Depth | Finish    | Basic No. |
| H3A            | 3"         | A - Alum. | -02CA     |
| H4A            | 4"         |           |           |
| H5A            | 5"         |           |           |
| H6A            | 6"         |           |           |
| H7A            | 7"         |           |           |

**EXAMPLE:** H4A -02CA for 4" load depth, aluminum Box Splice Plate.

### Hold-Down [9132]

**Note:** For seismic applications or other bolted connections is preferred.

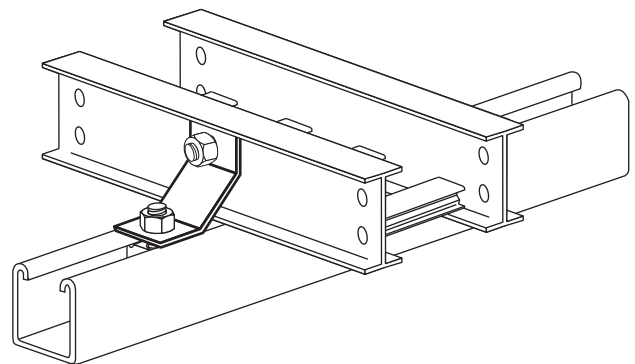

| Catalog No. | Material        |
|-------------|-----------------|
| 9132        | Mill Galvanized |
| 9133        | Stainless Steel |

Hardware purchased separately to suit support system.

# I-BEAM CABLE TRAY SYSTEM

## HARDWARE

### MATERIAL/FINISH

Electrogalvanized finish standard. Other finishes available; consult factory.

\*Use following suffix when applicable - use only where indicated.

**EG**..... Electrogalvanized carbon steel only

**-SS**..... 302/304 Stainless Steel

**-SS316**.. 316 Stainless Steel (check factory for availability)

*Example:* E-142- 3/8 x 1 1/2 SS, 3/8 x 1 1/2 hex head bolt, 304 stainless steel

### Connector Hardware

(Case-hardened steel electrogalvanized)

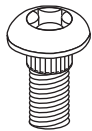

**Part No. 5003-1**  
3/8"-16 x 1" spline bolt



**Part No. 5009-1**  
3/8"-16 hex-flanged nut with serrated washer face.

### Cover Screw [E-150-S]

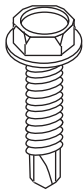

**E-150-S**  
Hex Head Lag Bolt



|                   |      |     |
|-------------------|------|-----|
| <b>Screw Size</b> | 3/8  | 1/2 |
| <b>Drill Size</b> | 5/16 | 3/4 |

See Price Sheet for Length.

### Continuous Threaded Rod [H-104]

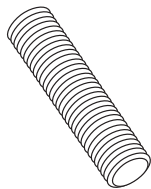

| Size | NATIONAL COARSE THREAD |              |                  |
|------|------------------------|--------------|------------------|
|      | Threads per inch       | lbs./100 ft. | Design Load lbs. |
| 1/4  | 20                     | 12.5         | 150              |
| 3/8  | 16                     | 29           | 610              |
| 1/2  | 13                     | 53.5         | 1130             |
| 5/8  | 11                     | 85           | 1810             |
| 3/4  | 10                     | 123          | 2710             |
| 7/8  | 9                      | 130          | 3770             |
| 1    | 8                      | 214          | 4960             |

### Rod Coupler [H-119]

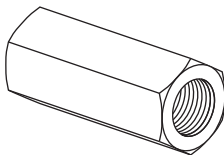

| Prod. #    | Rod Size | A     | Wt./C lbs. |
|------------|----------|-------|------------|
| H-119-1/4  | 1/4      | 1-3/4 | 9          |
| H-119-5/16 | 5/16     | 1-3/4 | 7          |
| H-119-3/8  | 3/8      | 1-3/4 | 10         |
| H-119-1/2  | 1/2      | 1-3/4 | 18         |
| H-119-5/8  | 5/8      | 2-1/8 | 23         |
| H-119-3/4  | 3/4      | 2-1/4 | 21         |
| H-119-7/8  | 7/8      | 2-1/2 | 55         |
| H-119-1    | 1        | 2-3/4 | 68         |

### Hex Nuts [E-145]



**E-145**  
Standard Hex Nut

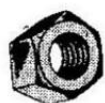

| Size | Wt./C lbs. |
|------|------------|
| 1/4  | .72        |
| 3/8  | 1.06       |
| 1/2  | 2.78       |
| 5/8  | 6.92       |
| 3/4  | 12.70      |
| 7/8  | 19.00      |
| 1    | 26.00      |

### Square Nuts [E-146]

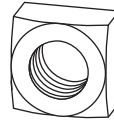

**E-146**  
Standard Square Nut



| Size | Wt./C lbs. |
|------|------------|
| 1/4  | .93        |
| 5/16 | 1.60       |
| 3/8  | 2.65       |
| 1/2  | 5.83       |
| 5/8  | 10.80      |

### Flat Washers [E-147]

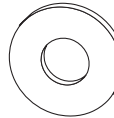

**E-147**  
Flat Steel Washer

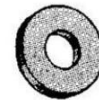

| Size | Wt./C lbs. |
|------|------------|
| 1/4  | .67        |
| 5/16 | 1.11       |
| 3/8  | 1.49       |
| 1/2  | 3.85       |
| 5/8  | 7.69       |
| 3/4  | 9.89       |
| 7/8  | 15.40      |

### Split-Lock Washers [E-148]

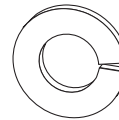

**E-148**  
Lock Washer



| Size | Wt./C lbs. |
|------|------------|
| 1/4  | .26        |
| 5/16 | .39        |
| 3/8  | .50        |
| 1/2  | 1.09       |
| 5/8  | 2.57       |

### Fender Washers [EF-147]

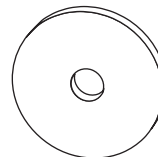

**EF-147**  
Fender Washer

| Size | A     | B    | Wt./C lbs. |
|------|-------|------|------------|
| 1/4  | 1-1/4 | 5/16 | 3.1        |
| 3/8  | 1-1/2 | 7/16 | 2.9        |
| 1/2  | 2     | 9/16 | 5.0        |

### Hex Head Cap Screw / Round Head, Slotted Cap Screw [E-142]

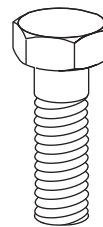

**E-142**  
Hex Head Cap Screw



| Size        | Wt./C lbs. |
|-------------|------------|
| 1/4 x 1     | 1.74       |
| 1/4 x 1-1/2 | 2.43       |
| 3/8 x 1     | 4.17       |
| 3/8 x 1-1/2 | 5.64       |
| 1/2 x 15/16 | 8.94       |
| 1/2 x 1-1/2 | 10.00      |

See Price Sheet For Additional Sizes

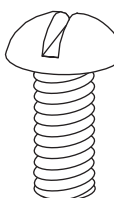

Catalog No. E-141

### Covers

**COVERS** for straight sections shown. Standard fitting covers are flat solid type (NF). Aluminum covers are fabricated from 0.040" aluminum AA-3150-H14.

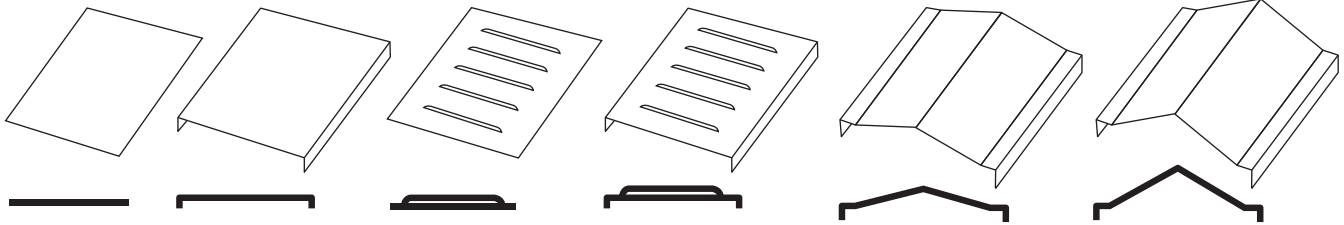

**NF** – Flat Solid

**FS** – Flat Solid  
w/ 3/8" Flange

**NL** – Flat Louvered

**PF** – Peaked Flanged  
Solid w/ 3/8" Flange  
(suffix height)

**PP** – Peaked 2 to 3 Pitch  
Flanged Solid  
w/ 3/8" Flange

**Note:** Use EM-CC Cover Screws (see pg. 88) to attach PH, PV, HS & HV covers.

**Cover Catalog Number – Straight Sections (Aluminum)**

| Type | Basic No. (Width)   | Length | Height* |
|------|---------------------|--------|---------|
| NFHA | -06SL = 6" (152mm)  | -12'   | -2"     |
| FSHA | -09SL = 9" (229mm)  | -10'   |         |
| NLHA | -12SL = 12" (305mm) | -06'   |         |
| PFHA | -18SL = 18" (457mm) |        |         |
| PPHA | -24SL = 24" (610mm) |        |         |
|      | -30SL = 30" (762mm) |        |         |
|      | -36SL = 36" (914mm) |        |         |

\*PF only, 2" height standard. Consult factory for other heights.

**EXAMPLE:** NLHA-09SL-12 is a flat louvered aluminum cover for a 9" wide I-Beam 12' long.

**Cover Catalog Number – Fittings (Aluminum)**

| Type | Load Depth | Width/Basic No. | Radius |
|------|------------|-----------------|--------|
| NFHA | 3"         | -06 XX **       | 12"    |
| FSHA | 4"         | -09 XX **       | 24"    |
|      | 5"         | -12 XX **       | 36"    |
|      | 6"         | -18 XX **       |        |
|      |            | -24 XX **       |        |
|      |            | -30 XX **       |        |
|      |            | -36 XX **       |        |

\* Load depth for outside riser or vertical tee only.

\*\* XX from fitting selection page 68

**EXAMPLE:** NFHG-369F-24 is a non-flanged solid cover for a 36" wide horizontal 90° elbow with a 24" radius.

### Joint Plate

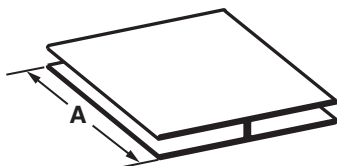

Joint plate is black PVC and is offered in 10' lengths to be field cut to desired length, or in precut lengths for specified covers.

**JP-120** is joint plate in 10' lengths.

Joint plate for specified covers is specified as follows.

**Tray Width -"A"**

|             |         |
|-------------|---------|
| JP-06 = 6"  | (152mm) |
| JP-09 = 9"  | (229mm) |
| JP-12 = 12" | (305mm) |
| JP-18 = 18" | (457mm) |
| JP-24 = 24" | (610mm) |
| JP-30 = 30" | (762mm) |
| JP-36 = 36" | (914mm) |

**EXAMPLE:** JP-06 is a joint plate for 6" wide tray.

## COVER ACCESSORIES

### Double Clamp Connector [DC]

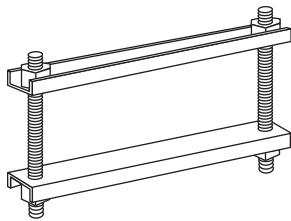

#### Catalog Number (Aluminum Clamp)

| Part | Load Depth | Width | Type |
|------|------------|-------|------|
| H3A  | 3"         | -06   | DC   |
| H4A  | 4"         | -09   |      |
| H5A  | 5"         | -12   |      |
| H6A  | 6"         | -18   |      |
| H7A  | 7"         | -24   |      |
|      |            | -30   |      |
|      |            | -36   |      |

For all covers except peaked.  
Furnished with:  
(2) 1/4"-20 all-thread rods  
(4) hex nuts, flat washers  
and lock washers  
Suggested spacing:  
Indoor: 2 per 12'  
Outdoor: 3 per 12'  
High Wind: 5 per 12'

**EXAMPLE:** H4A-12DC for 4" load depth, I-Beam flange, aluminum, Double Clamp Connector

### Peak Cover Connector [PC]

**Note:** For PF Covers

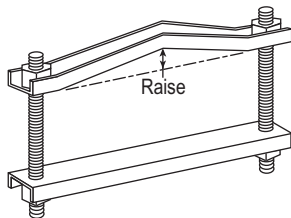

#### Catalog Number (Aluminum Clamp)

| Part | Load Depth | Width     | Type | Raise (in)* |
|------|------------|-----------|------|-------------|
| H3A  | 3"         | -06, -09, | PC   | -2          |
| H4A  | 4"         | -12, -18, |      |             |
| H5A  | 5"         | -24, -30  |      |             |
| H6A  | 6"         | -36       |      |             |
| H7A  | 7"         |           |      |             |

\*2" standard raise. Consult factory for other peak heights.

**EXAMPLE:** H4A-12PC-2 for 4" load depth, I-Beam flange, aluminum, 12" wide, Peak Cover Connector with 2" peak.

### Peak Pitch Cover Connector [PP]

**Note:** For PP Covers

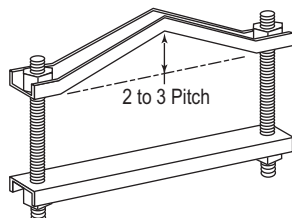

#### Catalog Number (Aluminum)

| Part | Load Depth | Width     | Type |
|------|------------|-----------|------|
| H3A  | 3"         | -06, -09, | PP   |
| H4A  | 4"         | -12, -18, |      |
| H5A  | 5"         | -24, -30, |      |
| H6A  | 6"         | -36       |      |
| H7A  | 7"         |           |      |

NOTE: 2 to 3 standard pitch.

**EXAMPLE:**  
H4A-12PP for 4" load depth,  
I-Beam flange, aluminum,  
12" wide, Pitched Peak Cover

### Elevated Cover Connectors [EM-CC]

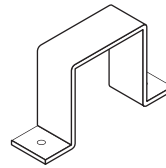

Includes:  
(3) #10 x 5/8" Self drilling screws.  
Suggested spacing:  
Indoor: 3/Side (6 tot.) per 12';

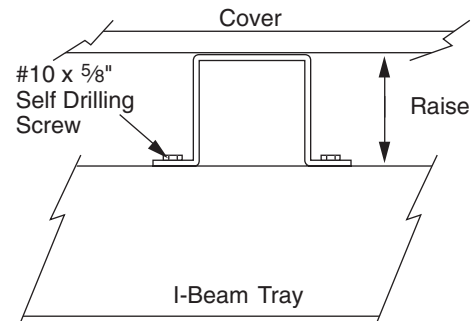

#### Catalog Number

| Finish    | Type  | Height*        |
|-----------|-------|----------------|
| 8 - Alum. | EM-CC | - Raise* (in.) |

\*1", 2" or 3" standard.

**EXAMPLE:** 8-EM-CC-2 for aluminum, Elevated Cover Connector with a 2" raise

### Electro-Galv. Steel Cover Clip [PS 135X]

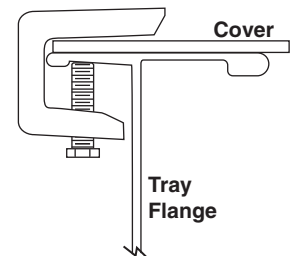
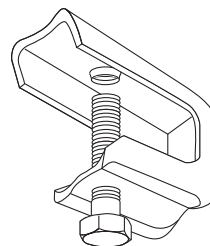

Use with any width tray. Not sold in pairs.  
Indoor use only. Suggest spacing 6' max.

### Box Connector [CB]

.080" Aluminum

**Note:** 1/4"-20 carriage bolts, flat washers, hex nuts furnished.

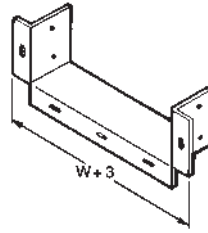

#### Catalog Number (Aluminum)

| Part | Load Depth | Width               |
|------|------------|---------------------|
| H3A  | 3"         | -06CB = 6" (152mm)  |
| H4A  | 4"         | -09CB = 9" (229mm)  |
| H5A  | 5"         | -12CB = 12" (305mm) |
| H6A  | 6"         | -18CB = 18" (457mm) |
| H7A  | 7"         | -24CB = 24" (610mm) |
|      |            | -30CB = 30" (762mm) |
|      |            | -36CB = 36" (914mm) |

**EXAMPLE:** H4A-12CB for I-Beam flange, 4" load depth, aluminum, 12" wide, Box Connector.

### Blind End [BE]

.040" Aluminum

**Note:** 3/8"-16 spline bolts and flange nuts furnished.

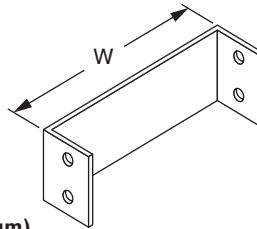

#### Catalog Number (Aluminum)

| Part | Load Depth | Width               |
|------|------------|---------------------|
| H3A  | 3"         | -06BE = 6" (152mm)  |
| H4A  | 4"         | -09BE = 9" (229mm)  |
| H5A  | 5"         | -12BE = 12" (305mm) |
| H6A  | 6"         | -18BE = 18" (457mm) |
| H7A  | 7"         | -24BE = 24" (610mm) |
|      |            | -30BE = 30" (762mm) |
|      |            | -36BE = 36" (914mm) |

**EXAMPLE:** H4A-12BE for I-Beam flange, 4" load depth, aluminum, 12" wide Blind End.

### Cable Tray Ground Clamp [9156]

Extruded Alum. with ElectroGalvanized Hex Head Screws

Capacity: #6 AWG to 250 kcmil

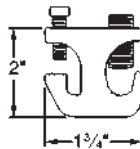
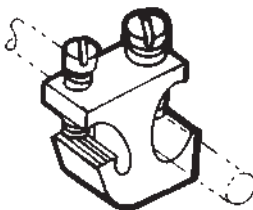

### Drop Out [DO]

.080" Aluminum

**Note:** (2) #10 x 5/8" self tapping screws furnished.

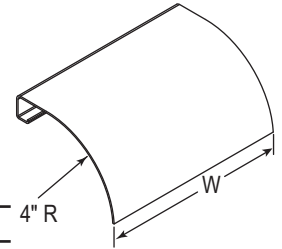

#### Catalog Number

| Basic Finish | Width               |
|--------------|---------------------|
| A - Alum.    | -06DO = 6" (152mm)  |
|              | -09DO = 9" (229mm)  |
|              | -12DO = 12" (305mm) |
|              | -18DO = 18" (457mm) |
|              | -24DO = 24" (610mm) |
|              | -30DO = 30" (762mm) |
|              | -36DO = 36" (914mm) |

**EXAMPLE:** A-12DO for aluminum, 12" wide, Drop Out.

### Bonding Jumper [CBJ]

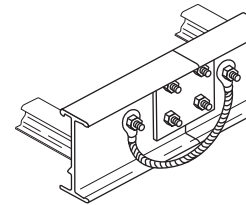

| Catalog No. | Dimensional Data                            | Amperes as Equipment Ground |
|-------------|---|-----------------------------|
| CBJ-C       | AWG 1/0 copper wire<br>15 1/2" long overall | 800 amperes                 |
| CBJ-4C      | AWG 4/0 copper wire<br>15 1/2" long overall | 1,600 amperes               |
| CBJ-250C    | 250 MCM copper wire<br>15 1/2" long overall | 2,000 amperes               |

**NOTE:**

No hardware supplied

For hardware kit add -HDW:

Ex: CBJ-C-HDW includes  
2ea CBJ-C  
4ea 5003-1  
4ea 5009-1

### Ground Cable Retainer Clamp

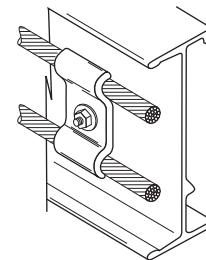

| Catalog No. | Capacity    | Metal & Finish      | Dimensions         |
|-------------|-------------|---------------------|--------------------|
| 9056-EP     | 1/0 2/0 3/0 | Electro-Galv. Steel | 1" w x 2" long     |
| 9057-EP     | 4/0 250 MCM |                     | 1" w x 2 3/8" long |
| 9056-SS     | 1/0 2/0 3/0 | Stainless Steel     | 1" w x 2" long     |
| 9057-SS     | 4/0 250 MCM |                     | 1" w x 2 3/8" long |

# I-BEAM CABLE TRAY SYSTEM



## ACCESSORIES

### Mustang Universal One-Piece Pipe, Conduit (GRC, EMT & IMC) and Tubing Clamps [PS MU]

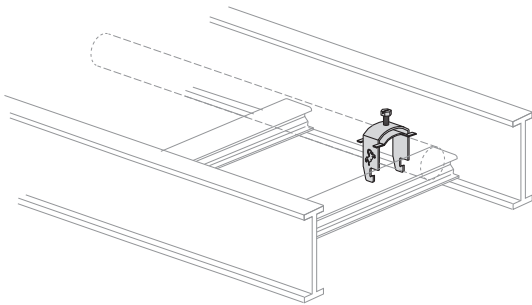

| Part No.    | Nominal Trade Size | OD     |        | Height Above Channel "H" |        |
|-------------|--------------------|--------|--------|--------------------------|--------|
|             |                    | Min    | Max    | Min                      | Max.   |
| PS MU-1/4   | 1/4"               | 0.250" | 0.540" | 1 3/4"                   | 2"     |
| PS MU-3/8   | 3/8"               | 0.500" | 0.675" | 1 7/8"                   | 2 1/8" |
| PS MU-1/2   | 1/2"               | 0.625" | 0.840" | 2"                       | 2 1/4" |
| PS MU-3/4   | 3/4"               | 0.875" | 1.050" | 2 1/4"                   | 2 1/2" |
| PS MU-1     | 1"                 | 1.125" | 1.315" | 2 1/2"                   | 2 3/4" |
| PS MU-1-1/4 | 1 1/4"             | 1.375" | 1.660" | 2 3/4"                   | 3 1/8" |
| PS MU-1-1/2 | 1 1/2"             | 1.625" | 1.900" | 3"                       | 3 3/8" |
| PS MU-2     | 2"                 | 2.000" | 2.375" | 3 1/2"                   | 3 7/8" |
| PS MU-2-1/2 | 2 1/2"             | 2.500" | 2.875" | 4 1/4"                   | 4 5/8" |
| PS MU-3     | 3"                 | 3.000" | 3.500" | 4 7/8"                   | 5 3/8" |
| PS MU-3-1/2 | 3 1/2"             | 3.625" | 4.000" | 5 3/8"                   | 5 7/8" |
| PS MU-4     | 4"                 | 4.125" | 4.500" | 5 7/8"                   | 6 3/8" |

**Note:**  
Available in 14 ga. Electro-galvanized steel

### Conduit Clamp Bracket [CCB]



| Catalog No. | Size-Rigid   | Size-EMT |
|-------------|--------------|----------|
| CCB-050     | 3/8" to 1/2" | 1/2"     |
| CCB-075     | 3/4"         | 3/4"     |
| CCB-100     | 1"           | 1"       |
| CCB-125     | -            | 1 1/4"   |
| CCB-150     | 1 1/4"       | 1 1/2"   |
| CCB-200     | 2"           | 2"       |

### Conduit-to-Cable Tray Clamp Swivel Type [TB]

Malleable iron hub and steel "U" bolt. For connecting and grounding rigid conduit to tray at any angle within 90° arc. U.L. listed as a grounding means.

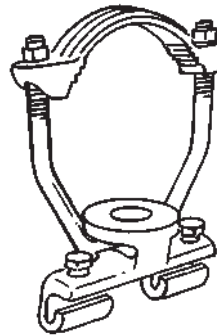

| Catalog No. | Size      | Std. Pkg. |
|-------------|-----------|-----------|
| TB6209      | 1/2"-3/4" | 10        |
| TB6211      | 1"-1 1/4" | 10        |
| TB6214      | 1 1/2"-2" | 5         |
| TB6216      | 2 1/2"-3" | 5         |
| TB6218      | 3 1/2"-4" | 2         |

### Wall Penetrating Sleeve Assembly

Part No. SS89042(W)\*

W = Tray Width  
\* = Fitting 3-Digit Prefix

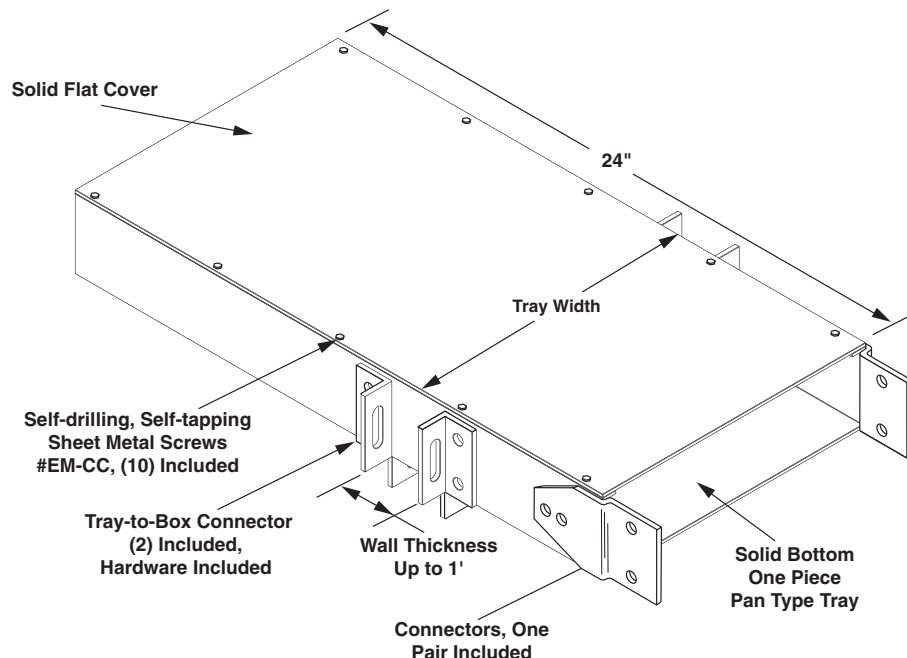

**Note:** Standard penetration sleeves are manufactured from mill galvanized steel. Aluminum sleeves are available upon request.

### Universal Aluminum Barrier Strip - Straight Section [SB]

#### Catalog Number (Aluminum)

| Part | Load Depth | Basic No. - Length |
|------|------------|--------------------|
| 3A   | 3"         | -01SB-10 = 10'     |
| 4A   | 4"         | -01SB-12 = 12'     |
| 5A   | 5"         |                    |
| 6A   | 6"         |                    |
| 7A   | 7"         |                    |

**EXAMPLE:** 4A-01SB-12 for I-Beam flange, 4" load depth, aluminum straight barrier, 12' long.

Furnished with 8 self tapping screws.

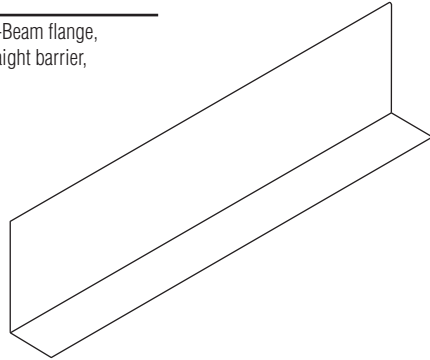

### Barrier Strip Vertical Elbow Outside [OB] & Inside [IB]

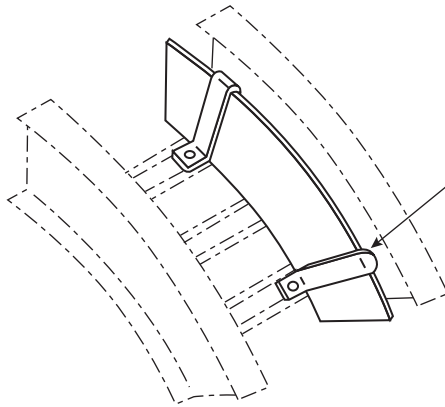

Barrier Strip Clamp  
Part No. 50172  
Furnished with vertical elbow barriers

#### Catalog Number (Aluminum)

| Part | Load Depth | Bend (deg.) | Basic No.    | Radius      |
|------|------------|-------------|--------------|-------------|
| 3A   | 3"         | 90°         | OB = Outside | 12" (305mm) |
| 4A   | 4"         | 60°         | IB = Inside  | 24" (610mm) |
| 5A   | 5"         | 45°         |              | 36" (914mm) |
| 6A   | 6"         | 30°         |              |             |
| 7A   | 7"         |             |              |             |

**EXAMPLE:** 3A-90OB-12 for I-Beam flange, 3" load depth, aluminum 90° outside vertical barrier with 12" radius. (OB Vert. Elbow outside shown)  
Furnished with sufficient clamp assemblies for installation.  
Additional clamp assemblies may be ordered separately.

### Barrier Strip - Horizontal Fitting [FB]

#### Catalog Number (Aluminum)

| Part | Load Depth | Basic No. 6' Length |
|------|------------|---------------------|
| 3A   | 3"         | -01FB-06            |
| 4A   | 4"         |                     |
| 5A   | 5"         |                     |
| 6A   | 6"         |                     |
| 7A   | 7"         |                     |

**EXAMPLE:** 4A-01FB-06 for I-Beam flange, 4" load depth, aluminum fitting barrier, 6' long.

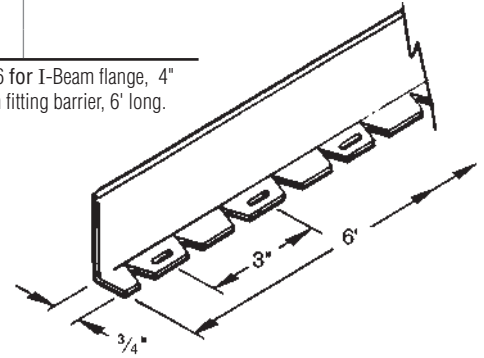

### Nylon Barrier Splice & Protector [BSP-L]

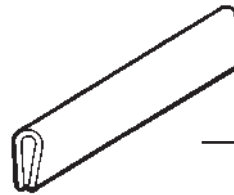

#### Catalog Number

| Prefix | Length (L)            |
|--------|-----------------------|
| BSP    | -5 (5" Splice)        |
|        | -144 (144" Protector) |
|        | -1200 (100' Roll)     |

**EXAMPLE:** BSP-1200 for 100' roll

### Barrier Strip Clamp (Optional) [50172]

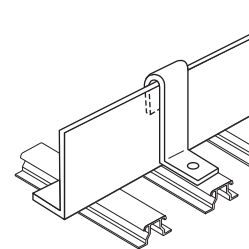

No. 10 bolt, nut, washer and lockwasher furnished.

#### Catalog Number (Aluminum)

| Part | Load Depth | Basic No. |
|------|------------|-----------|
| H3A  | 3"         | -50172    |
| H4A  | 4"         |           |
| H5A  | 5"         |           |
| H6A  | 6"         |           |
| H7A  | 7"         |           |

**EXAMPLE:** H3A-5072 for I-Beam flange, 3" load depth, aluminum clamp.

## SUPPORTS

### Gusset-Type Supports

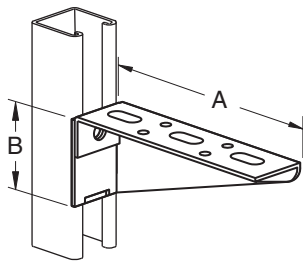

For use with all types of Cope I-Beam systems. Finish is electro-galvanized. Order hardware separately.

| Catalog No. | I-Beam Width | Dimension |                                   | Uniform-Load Rating |
|-------------|--------------|-----------|-----------------------------------|---------------------|
|             |              | A         | B                                 |                     |
| PS 838R-12  | 6"           | 12"       | 3 <sup>7</sup> / <sub>16</sub> "  | 275 lbs.            |
| PS 838R-16  | 9"           | 16"       | 4 <sup>7</sup> / <sub>16</sub> "  | 275 lbs.            |
| PS 838R-18  | 12"          | 18"       | 4 <sup>15</sup> / <sub>16</sub> " | 275 lbs.            |
| PS 838R-24  | 18"          | 24"       | 6 <sup>7</sup> / <sub>16</sub> "  | 275 lbs.            |
| PS 838R-30  | 24"          | 30"       | 7 <sup>15</sup> / <sub>16</sub> " | 275 lbs.            |

### Channel-Type Supports

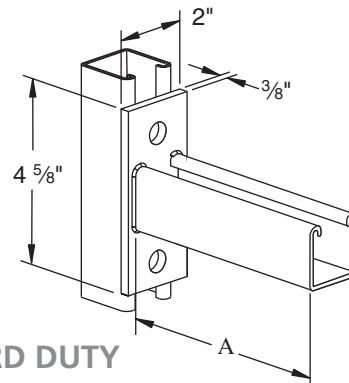

#### STANDARD DUTY

For use with all types of Cope I-Beam systems. Finish is electro-galvanized. Order hardware separately.

#### Standard Duty for Lighter Loads.

| Catalog No. | I-Beam Width | Dimension A | Uniform-Load Rating* |
|-------------|--------------|-------------|----------------------|
| PS 651-12   | 6"           | 12"         | 600 lbs.             |
| PS 651-15   | 9"           | 15"         | 480 lbs.             |
| PS 651-18   | 12"          | 18"         | 400 lbs.             |
| PS 651-24   | 18"          | 24"         | 300 lbs.             |
| PS 651-30   | 24"          | 30"         | 240 lbs.             |

\* Mounted on 12 Ga. Channel.

### Double Channel-Type Supports

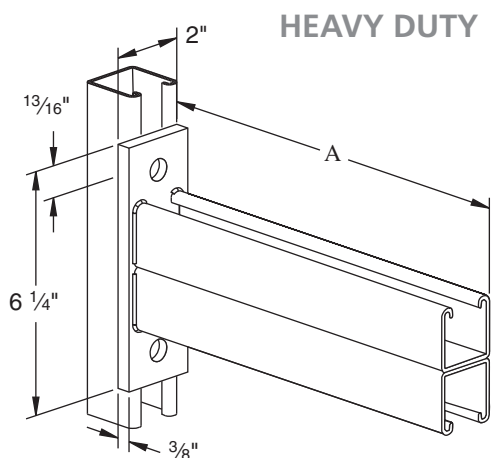

For use with all types of Cope I-Beam systems. Finish is electro-galvanized. Order hardware separately.

#### Heavy Duty for Heavier Loads

| Catalog No. | I-Beam Width | Dimension A | Uniform-Load Rating* |
|-------------|--------------|-------------|----------------------|
| PS 809-12   | 6"           | 12"         | 2,000 lbs.           |
| PS 809-15   | 9"           | 15"         | 1,600 lbs.           |
| PS 809-18   | 12"          | 18"         | 1,330 lbs.           |
| PS 809-24   | 18"          | 24"         | 1,000 lbs.           |
| PS 809-30   | 24"          | 30"         | 800 lbs.             |
| PS 809-36   | 30"          | 36"         | 660 lbs.             |
| PS 809-42   | 36"          | 42"         | 570 lbs.             |

\* Mounted on 12 Ga. Channel.

## SUPPORT BRACKETS & TRAY HANGERS

### Wall Support Brackets

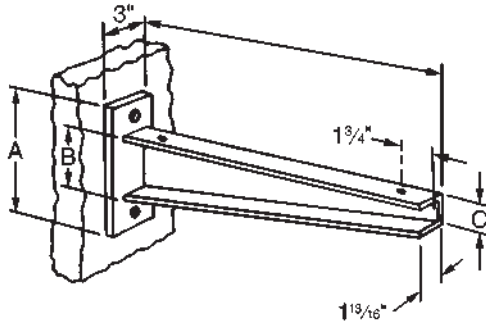

| Catalog Number | Ladder Width | Length "L" | Dimensions |     |        | End-Load Rating* |
|----------------|--------------|------------|------------|-----|--------|------------------|
|                |              |            | "A"        | "B" | "C"    |                  |
| 9037-12        | 6"           | 12 1/4"    | 10"        | 6"  | 2"     | 2000 lbs.        |
| 9037-18        | 12"          | 18 1/4"    | 11"        | 7"  | 2 1/2" | 2000 lbs.        |
| 9037-24        | 18"          | 24 1/4"    | 11"        | 7"  | 2 1/2" | 1600 lbs.        |
| 9037-30        | 24"          | 30 1/4"    | 12"        | 8"  | 4"     | 1300 lbs.        |
| 9037-36        | 30"          | 36 1/4"    | 12"        | 8"  | 4"     | 1100 lbs.        |
| 9037-42        | 36"          | 42 1/4"    | 12"        | 8"  | 4"     | 900 lbs.         |

\*Uniform load rating is normally twice the end-load rating.  
Finish is hot-dip galvanized after fabrication.  
Order hardware separately

### Structural Support Bracket

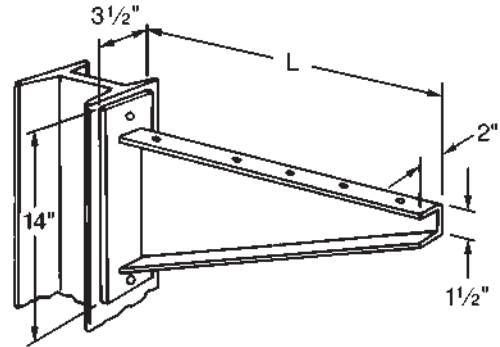

| Catalog No. | Ladder Width | Length "L" | End-Load Rating* |
|-------------|--------------|------------|------------------|
| 9036-31     | 24"          | 31 1/4"    | 2000 lbs.        |
| 9036-37     | 30"          | 37 1/4"    | 1800 lbs.        |
| 9036-45     | 36"          | 45 1/4"    | 1500 lbs.        |

\*Uniform load rating is normally twice the end-load rating.  
For use with Cope I-Beam 24" or wider. May be welded or bolted to building steel.  
Finish is hot-dip galvanized after fabrication.  
Order hardware separately.

COPE™ I-BEAM™

### Power-Pier Rooftop Support System

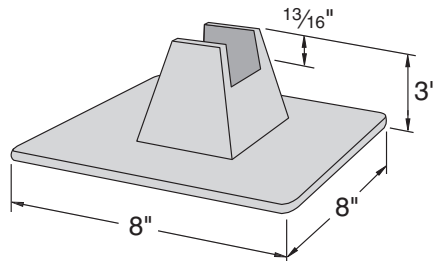

The Power-Pier Rooftop support system provides a simple and versatile way to support and manage pipe, tubing, conduit, HVAC systems, and the like. The Power-Pier system supports without roof surface penetration and allows the parts to remain off the surface

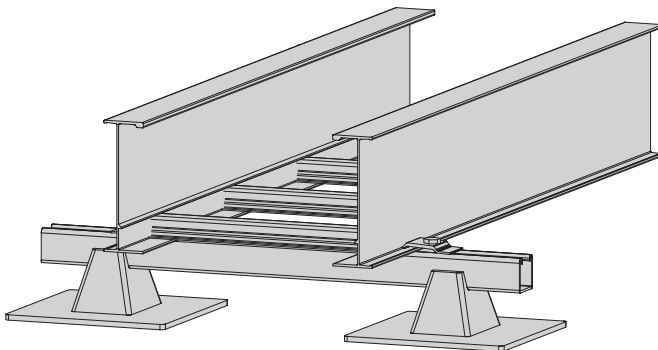

| Part Number  | Power-Pier Bases Qty. | I-Beam Width | Description   |
|--------------|-----------------------|--------------|---|
| PS PP        | 4                     | -            | Power-Pier Base Only (4 Bases & Hardware)               |
| PS-SPSS-10HG | 4                     | 6"           | PS PP + 4 Pcs PS 500 EH HG @ 10" Long for 4" to 8" Pipe |
| PS-MPDS-13HG | 4                     | 9"           | PS PP + 2 Pcs PS 200 EH HG @ 13" Long for Trapeze       |
| PS-MPDS-16HG | 4                     | 12"          | PS PP + 2 Pcs PS 200 EH HG @ 16" Long for Trapeze       |
| PS-MPDS-22HG | 4                     | 18"          | PS PP + 2 Pcs PS 200 EH HG @ 22" Long for Trapeze       |
| PS-MPDS-28HG | 4                     | 24"          | PS PP + 2 Pcs PS 200 EH HG @ 28" Long for Trapeze       |
| PS-MPDS-34HG | 4                     | 30"          | PS PP + 2 Pcs PS 200 EH HG @ 34" Long for Trapeze       |
| PS-MPDS-40HG | 4                     | 36"          | PS PP + 2 Pcs PS 200 EH HG @ 40" Long for Trapeze       |

## TRAY HANGER & SUPPORTS

### Single Rod Hanger Support

| Catalog Number |                 |                         |                        |                       |                |
|----------------|-----------------|-------------------------|------------------------|-----------------------|----------------|
| Assy. Type     | Channel Length* | Channel Finish**        | Rod Diameter           | Rod Length            | Beam Clamp     |
| P200           | 14"<br>(356mm)  | GV<br>(Pre-Galv)        | 38=3/8"<br>(9.53mm)    | 000 - No Rod          | A - Bridgeport |
|                | 17"<br>(432mm)  |                         | 12=1/2"<br>(12.7mm)    | 036 - 36"<br>(914mm)  | B - P2622      |
|                | 20"<br>(508mm)  | HG<br>(Hot Dipped Galv) |                        | 072 - 72"<br>(1828mm) | O - No Clamp   |
|                | 26"<br>(661mm)  |                         | 120 - 120"<br>(3048mm) | R - Rod Coupler       |                |
|                | 32"<br>(813mm)  |                         | 144 - 144"<br>(3658mm) | S - Special           |                |
|                | 38"<br>(966mm)  |                         |                        |                       |                |
|                | 44"<br>(1118mm) |                         |                        |                       |                |

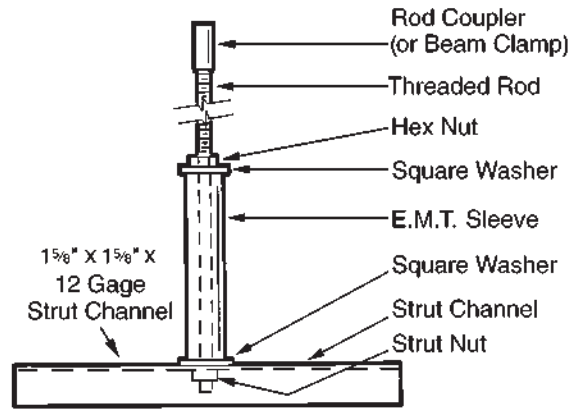

**EXAMPLE:**

P20020GV12036B is a Single 20" pre-galvanized channel with 1/2" x 36" drop rod and P2622 clamp.

**NOTE:**

- \*Order channel length 8" longer than tray width. For example, 44" channel for 36" tray.
- \*\* Other channel types and finishes available upon request. Contact factory.
- To order hardware only:  
3/8" - PGV380000  
1/2" - PGV120000

### Trapeze Hanger Support

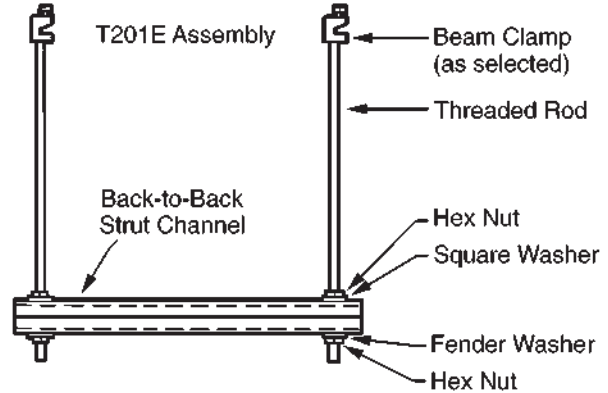
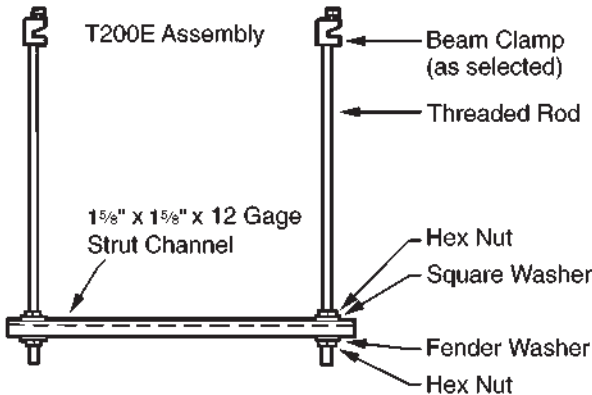

Catalog Number

| Assy. Type | Channel Length* | Channel Finish**     | Rod Diameter        | Rod Length             | Beam Clamp      |
|------------|-----------------|----------------------|---------------------|------------------------|-----------------|
| T200E      | 16"<br>(407mm)  | GV (Pre-Galv)        | 38=3/8"<br>(9.53mm) | 000 - No Rod           | A - PS 85       |
| T201E      | 19"<br>(483mm)  | HG (Hot Dipped Galv) | 12=1/2"<br>(12.7mm) | 036 - 36"<br>(914mm)   | B - P2622       |
|            | 22"<br>(559mm)  |                      |                     | 072 - 72"<br>(1828mm)  | O - No Clamp    |
|            | 28"<br>(712mm)  |                      |                     | 120 - 120"<br>(3048mm) | R - Rod Coupler |
|            | 34"<br>(864mm)  |                      |                     | 144 - 144"<br>(3658mm) | S - Special     |
|            | 40"<br>(1017mm) |                      |                     |                        |                 |
|            | 46"<br>(1169mm) |                      |                     |                        |                 |

**EXAMPLE:** T200E22GV12036B is a Single 22" pre-galvanized channel with 1/2" x 36" drop rod and P2622 clamp.

- NOTE:**
- \*Order channel length 10" longer than tray width. For example, 46" channel for 36" tray.
  - \*\* Other channel types and finishes available upon request. Contact factory.
  - To order hardware only:  
3/8" - PGV380000  
1/2" - PGV120000

## Electrical Grounding Chart

| Fitting Prefix Number |            | Min. X-Sect for 2 Rails<br>(NEC Table 392.7B)<br>Aluminum I-Beam<br>X-Sect Area | Maximum Ground<br>Fault Amperage<br>(in Amps)<br>Aluminum |
|-----------------------|------------|---|---|
| System                | Load Depth |   |   |
| 5H3A                  | 3"         | 1.00  | 1,200   |
| 5H4A                  | 4"         | 1.00  | 1,200   |
| 1H5A                  | 5"         | 1.50  | 1,600   |
| 5H5A                  | 5"         | 1.50  | 1,600   |
| 7H5A                  | 5"         | 2.00  | 2,000   |
| 9H5A                  | 5"         | 2.00  | 2,000   |
| 7H6A                  | 6"         | 2.00  | 2,000   |
| 9H6A                  | 6"         | 2.00  | 2,000   |
| 11H7A                 | 7"         | 2.00  | 2,000   |

The table to the left provides the Minimum Cross Sectional area for two side rails. Using the Fitting Prefix Number (H4A), the proper value is determined by the Material (column 3), the Flange (column 1) and Load Depth (column 2). Locate the line containing the Load Depth (column 1) and follow it to the right to the appropriate Flange and Material.

Find that value in Maximum Ground Fault (column 4), follow it to the right to the Material column to determine the Maximum Ground Fault Amperage.

**For Example:**  
If the fitting prefix is H4A, the Flange is I-Beam, the Load Depth is 4", and the Material is Aluminum. The Minimum Cross Sectional Area (X-Sect Area) is 1.00 sq. in. The Amperage is 1,200.

## Typical Specifications

By specifying the NEMA class designation, you will use the simplest, clearest, and most complete method of specification available and automatically incorporate support span in feet, working (allowable) load in pounds per linear foot, a safety factor of 1.5, a concentrated load if present; and, all other design, manufacturing and test standards including electrical continuity.

All you need to do is add the desired load depth, rung spacing, radius of fittings, metal and finish. You may add accessory information pursuant to your project. Here is a typical specification for an outdoor tray system where the working (allowable) load has been determined to be approximately 75 pounds per foot on support spans of 12'-0".

### SPECIFICATION ALUMINUM AB-COPE I-BEAM SYSTEM

Cable I-Beam shall be manufactured by a company regularly engaged in the manufacture of metal cable trays and shall be a member of NEMA. Trays shall conform to NEMA Metal Cable Tray Standard Publication VE-1 (latest issue).

1. Cable I-Beam shall be NEMA Classification 12B of the widths indicated.
2. Material shall be aluminum alloy with side rails and rungs of 6063.
3. Finish shall be natural.
4. Inside load depth to be NEMA Standard 4".
5. Fittings shall be 12" radius for control cables and 24" radius for power cables. (This must be commensurate with the cable manufacturers' recommended minimum bending radius.)
6. All top level trays in stacks, and single runs to have raised peaked, aluminum ventilated covers with heavy duty hold down clamps every 3'-0".
7. Install expansion connectors, expansion guides, and hold down clamps per NEMA Standard VE-1.
8. Where slopes or horizontal bends of trays are not at the Standard NEMA angles, use adjustable connectors. If the angle is too great for cable bending radius, use combinations of fitting and adjustable connectors.
9. Separate all cables of different volt ages in the same tray using the manufacturer's standard barriers and barrier hold down system.
10. The Cable I-Beam system will be used as an equipment grounding conductor.
11. To save space fittings shall have 3" tangents. To facilitate field installation use one pair of universal type connector plates for rigid joints.
12. Trays shall be AB-Cope Cable I-Beam System Number 5H4A as manufactured by AB-Cope standard design.





# AB-COPE HAT

# 5



**Economical Flange in Welded Cable Ladder/Trof System for Electrical, Telephone, Computer Control & Instrumentation Cable**

**Slotted Rungs** provided on trays 6", 9", 12", 18" and 24" wide.  
**Solid Rungs** provided on trays 30" and 36" wide.

## CONTENTS

### General & Technical Information

|  |           |
|--|-----------|
| Selection Chart: Cope Hat - Aluminum ..... | 103 - 104 |
| Selection Chart: Cope Hat - Steel .....    | 105 - 106 |
| Overview .....                             | 107 - 108 |
| Ordering Information .....                 | 109       |
| Straight Length .....                      | 110       |

### AB-Cope Hat Fittings

|  |                |
|--|----------------|
| Horizontal Elbows                      |                |
| 90° .....                              | 111            |
| 60° .....                              | 111            |
| 45° .....                              | 112            |
| 30° .....                              | 112            |
| Horizontal Tee .....                   | 113, 115       |
| Horizontal Cross .....                 | 114, 116 - 117 |
| Straight Reducers .....                | 118            |
| Left and Right Hand Reducers .....     | 118            |
| Adjustable Elbow .....                 | 119            |
| 45° "Y" Branch .....                   | 119            |
| Vertical Elbows (Inside and Outside)   |                |
| 90° .....                              | 120            |
| 60° .....                              | 120            |
| 45° .....                              | 121            |
| 30° .....                              | 121            |
| 90° Vertical Cable Support Elbow ..... | 122            |
| Vertical Tee .....                     | 122            |

### Connectors & Hardware

|   |     |
|---|-----|
| Universal Curvilinear Connector, Expansion,<br>Horizontal and Vertical Adjustable, Reducing and 90° Connector ..... | 123 |
| General Hardware .....  | 124 |

### Covers

|   |     |
|---|-----|
| Covers, Joint Plate .....   | 125 |
| Cover Attachments (Hold down clamps,<br>Elevated and Peaked Cover Connectors) ..... | 126 |

### Accessories

|   |     |
|---|-----|
| Blind End, Drop Out, Bonding Jumper, Box Connector,<br>Cable Tray Ground Clamp, Ground Cable Retainer Clamp ..... | 127 |
| Conduit Clamp, Wall Sleeve .....  | 128 |
| Barrier Strips, Nylon Protector .....   | 129 |
| Hold Down Clamp, Seismic Hold-Down Clip, Barrier Strip Clamps .....   | 130 |
| Channel Supports, Gusset-Type Supports, Support Brackets .....  | 131 |
| Vertical Supports, Hanger Support, Trapeze Hanger Support .....   | 132 |

### Specification Information

|                                  |     |
|----------------------------------|-----|
| Electrical Grounding Chart ..... | 133 |
| Typical Specification .....      | 133 |

## Straight Length

Page 110

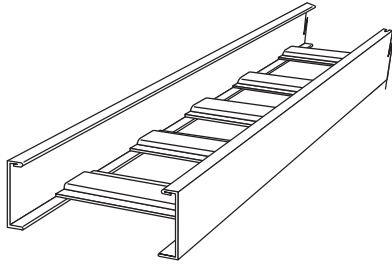

## Horizontal Elbows

Pages 111 - 112

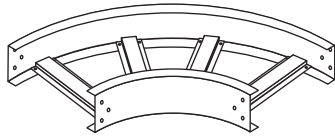

## Horizontal Tee

Page 113, 115

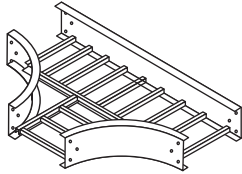

## Horizontal Cross

Page 114, 116 - 117

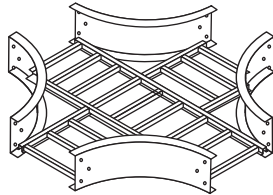

## Reducers

Page 118

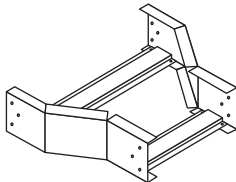

## Adjustable Elbows

Page 119

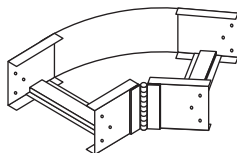

## 45° "Y" Branch

Page 119

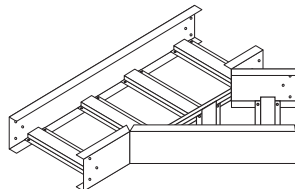

## Vertical Elbows

Pages 120 - 121

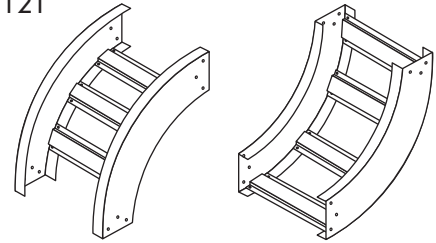

## 90° Vertical Cable Support Elbow

Page 122

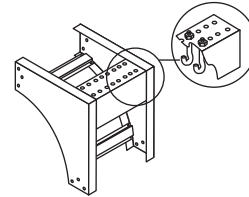

## Vertical Tee

Page 122

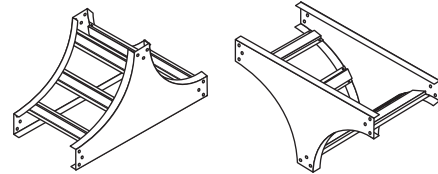

## Connectors

Pages 123 - 124

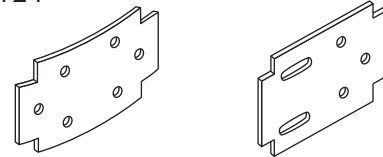

## Covers

Page 125

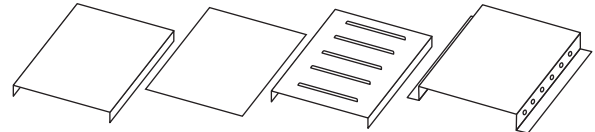

## Cover Attachments

Page 126

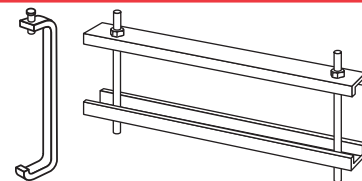

## Barrier Strips and Accessories

Pages 127 - 132

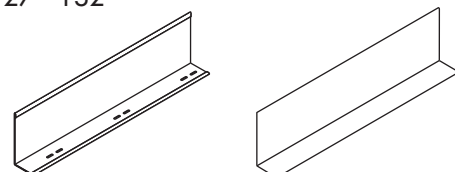

# HAT CABLE TRAY SYSTEM



## SELECTION CHART: Aluminum Tray

### NEMA CLASS, PHYSICAL AND STRUCTURAL PROPERTIES

| NEMA Standard VE-1 Load/Span Class  | Actual NEMA Load/Span   | Cope System Number | Nominal Load Depth |         | Side Rail Height |         | Flange Width (in.) | Section Modulus of 2 Rails Sx (in. <sup>3</sup> ) | Moment of Inertia for 2 Rails Ix (in. <sup>4</sup> ) | Min X-Sect. Area of 2 Rails per NEC 392.7 (in. <sup>2</sup> ) |
|---|-------------------------|--------------------|--------------------|---------|------------------|---------|--------------------|---|--|---|
| <b>8A-12A</b>   | 50 lb./ft.<br>12' span  | <b>523A</b>        | 3"                 | (76mm)  | 3 1/2"           | (89mm)  | 1 3/16"            | 0.800   | 1.400  | 0.60  |
|   |                         | <b>1B4A</b>        | 4"                 | (102mm) | 4 1/4"           | (108mm) | 1 3/16"            | 1.898   | 1.822  | 0.60  |
|   |                         | <b>1B5A</b>        | 5"                 | (127mm) | 5 1/4"           | (133mm) | 1 3/16"            | 1.142   | 2.872  | 0.60  |
|   |                         | <b>3B6A</b>        | 6"                 | (152mm) | 6 1/4"           | (159mm) | 1 3/16"            | 1.614   | 4.720  | 1.00  |
| <b>12B</b>  | 12' span                | <b>3B4A</b>        | 4"                 | (102mm) | 4 1/4"           | (108mm) | 1 3/16"            | 1.148   | 2.316  | 0.60  |
|   |                         | <b>1B5A</b>        | 5"                 | (127mm) | 5 1/4"           | (133mm) | 1 3/16"            | 1.142   | 2.872  | 0.60  |
|   |                         | <b>3B6A</b>        | 6"                 | (152mm) | 6 1/4"           | (159mm) | 1 3/16"            | 1.614   | 4.720  | 0.60  |
| <b>12C</b>  | 100 lb./ft.<br>12' span | <b>5B4A</b>        | 4"                 | (102mm) | 4 1/4"           | (108mm) | 1 3/16"            | 1.646   | 3.058  | 1.00  |
|   |                         | <b>3B5A</b>        | 5"                 | (127mm) | 5 1/4"           | (133mm) | 1 3/16"            | 1.522   | 3.734  | 1.00  |
|   |                         | <b>5B6A</b>        | 6"                 | (152mm) | 6 1/4"           | (159mm) | 1 3/16"            | 1.944   | 5.866  | 1.00  |
| <b>16A</b>  | 50 lb./ft.<br>16' span  | <b>5B4A</b>        | 4"                 | (102mm) | 4 1/4"           | (108mm) | 1 3/16"            | 1.646   | 3.058  | 1.00  |
|   |                         | <b>745A</b>        | 5"                 | (127mm) | 5 1/4"           | (133mm) | 1 1/4"             | 2.396   | 6.292  | 1.50  |
|   |                         | <b>1D6A</b>        | 6"                 | (152mm) | 6 1/4"           | (159mm) | 1 1/4"             | 2.378   | 7.202  | 1.00  |
| <b>16B</b>  | 75 lb./ft.<br>16' span  | <b>3D4A</b>        | 4"                 | (102mm) | 4 1/4"           | (108mm) | 1 1/4"             | 2.242   | 4.406  | 1.00  |
|   |                         | <b>745A</b>        | 5"                 | (127mm) | 5 1/4"           | (133mm) | 1 1/4"             | 2.396   | 6.292  | 1.50  |
|   |                         | <b>1D6A</b>        | 6"                 | (152mm) | 6 1/4"           | (159mm) | 1 1/4"             | 2.378   | 7.202  | 1.00  |
| <b>16C</b>  | 100 lb./ft.<br>16' span | <b>5D4A</b>        | 4"                 | (102mm) | 4 1/4"           | (108mm) | 1 1/4"             | 2.782   | 5.738  | 1.50  |
|   |                         | <b>3D5A</b>        | 5"                 | (127mm) | 5 1/4"           | (133mm) | 1 1/4"             | 3.434   | 8.746  | 2.00  |
|   |                         | <b>7D6A</b>        | 6"                 | (152mm) | 6 1/4"           | (159mm) | 1 1/4"             | 4.186   | 12.024   | 2.00  |
| <b>20A</b>  | 50 lb./ft.<br>20' span  | <b>3D4A</b>        | 4"                 | (102mm) | 4 1/4"           | (108mm) | 1 1/4"             | 2.242   | 4.406  | 1.00  |
|   |                         | <b>745A</b>        | 5"                 | (127mm) | 5 1/4"           | (133mm) | 1 1/4"             | 2.396   | 6.292  | 1.50  |
|   |                         | <b>1D6A</b>        | 6"                 | (152mm) | 6 1/4"           | (159mm) | 1 1/4"             | 2.378   | 7.202  | 1.00  |
| <b>20B</b>  | 75 lb./ft.<br>20' span  | <b>3D5A</b>        | 5"                 | (127mm) | 5 1/4"           | (133mm) | 1 1/4"             | 3.434   | 8.746  | 2.00  |
|   |                         | <b>7D6A</b>        | 6"                 | (152mm) | 6 1/4"           | (159mm) | 1 1/4"             | 4.186   | 12.024   | 2.00  |
| <b>20C</b>  | 100 lb./ft.<br>20' span | <b>5D5A</b>        | 5"                 | (127mm) | 5 1/4"           | (108mm) | 1 1/4"             | 3.910   | 10.020   | 2.00  |
|   |                         | <b>7D6A</b>        | 6"                 | (152mm) | 6 1/4"           | (133mm) | 1 1/4"             | 4.1860  | 12.024   | 2.00  |
| <b>EXTRA HEAVY DUTY - VERY LONG SPAN TRAYS- 4", 6" OR 9" RUNG SPACING</b> |                         |                    |                    |         |                  |         |                    |   |  |   |
|   |                         | <b>9D6A</b>        | 6"                 | (152mm) | 6 1/4"           | (159mm) | 1 1/4"             | 5.130   | 15.700   | 2.00  |
|   |                         | <b>7G6A</b>        | 6"                 | (152mm) | 6 1/4"           | (159mm) | 2"                 | 5.804   | 17.456   | 2.00  |

**Note:** ■ indicates most common systems. Consult factory for lead times on other systems.

**Slotted Rungs** provided on trays 6", 9", 12", 18" and 24" wide.

**Solid Rungs** provided on trays 30" and 36" wide.

## SELECTION CHART: Aluminum Tray

### LOAD AND DEFLECTION DATA FOR ALUMINUM HAT Working (Allowable) Load Capacity, Evenly Distributed-Tested per NEMA Standard VE-1, Simple Beam - SAFETY FACTOR 1.5

| Cope<br>Sys. No. | 6 Ft. Span |     |      | 8 Ft. Span |     |      | 10 Ft. Span |      |      | 12 Ft. Span |      |      | 16 Ft. Span |      |      | 20 Ft. Span |      |      | 24 Ft. Span |      |      | 25 Ft. Span |      |      |  |
|------------------|------------|-----|------|------------|-----|------|-------------|------|------|-------------|------|------|-------------|------|------|-------------|------|------|-------------|------|------|-------------|------|------|--|
|                  | w          | d   | k    | w          | d   | k    | w           | d    | k    | w           | d    | k    | w           | d    | k    | w           | d    | k    | w           | d    | k    | w           | d    | k    |  |
| 523A             | 207        | .43 | .002 | 117        | .77 | .007 | 75          | 1.20 | .016 | 52          | 1.73 | .033 |             |      |      |             |      |      |             |      |      |             |      |      |  |
| 1B4A             | 222        | .35 | .002 | 125        | .63 | .005 | 80          | .99  | .012 | 55          | 1.42 | .026 |             |      |      |             |      |      |             |      |      |             |      |      |  |
| 1B5A             | 324        | .33 | .001 | 182        | .59 | .003 | 117         | .87  | .007 | 77          | 1.26 | .016 |             |      |      |             |      |      |             |      |      |             |      |      |  |
| 3B6A             | 359        | .22 | †    | 191        | .37 | .002 | 115         | .55  | .005 | 75          | .74  | .010 |             |      |      |             |      |      |             |      |      |             |      |      |  |
| 3B4A             | 354        | .45 | .001 | 191        | .76 | .004 | 117         | 1.14 | .010 | 78          | 1.57 | .020 |             |      |      |             |      |      |             |      |      |             |      |      |  |
| 1B5A             | 324        | .33 | .001 | 182        | .59 | .003 | 117         | .87  | .007 | 77          | 1.26 | .016 |             |      |      |             |      |      |             |      |      |             |      |      |  |
| 3B6A             | 359        | .22 | †    | 191        | .37 | .002 | 115         | .55  | .005 | 75          | .74  | .010 |             |      |      |             |      |      |             |      |      |             |      |      |  |
| 5B4A             | 362        | .32 | †    | 251        | .69 | .003 | 161         | 1.08 | .007 | 112         | 1.55 | .014 |             |      |      |             |      |      |             |      |      |             |      |      |  |
| 3B5A             | 394        | .31 | †    | 222        | .55 | .002 | 142         | .86  | .006 | 100         | 1.24 | .012 |             |      |      |             |      |      |             |      |      |             |      |      |  |
| 5B6A             | 480        | .24 | †    | 257        | .40 | .002 | 156         | .60  | .004 | 102         | .81  | .008 |             |      |      |             |      |      |             |      |      |             |      |      |  |
| 5B4A             |            |     |      | 251        | .69 | .003 | 161         | 1.08 | .007 | 112         | 1.55 | .014 | 51          | 2.26 | .044 | 25          | 2.75 | .110 |             |      |      |             |      |      |  |
| 745A             |            |     |      | 349        | .51 | .001 | 223         | .80  | .004 | 155         | 1.15 | .007 | 79          | 1.85 | .023 | 51          | 2.89 | .057 |             |      |      |             |      |      |  |
| 1D6A             |            |     |      | 380        | .49 | .001 | 222         | .69  | .003 | 154         | 1.00 | .006 | 78          | 1.61 | .021 | 50          | 2.51 | .050 |             |      |      |             |      |      |  |
| 3D4A             |            |     |      | 342        | .72 | .002 | 219         | 1.12 | .005 | 152         | 1.61 | .011 | 82          | 2.74 | .033 | 52          | 4.27 | .082 |             |      |      |             |      |      |  |
| 745A             |            |     |      | 349        | .51 | .001 | 223         | .80  | .004 | 155         | 1.15 | .007 | 79          | 1.85 | .023 | 51          | 2.89 | .057 |             |      |      |             |      |      |  |
| 1D6A             |            |     |      | 380        | .49 | .001 | 222         | .69  | .003 | 154         | 1.00 | .006 | 78          | 1.61 | .021 | 50          | 2.51 | .050 |             |      |      |             |      |      |  |
| 5D4A             |            |     |      | 444        | .71 | .002 | 284         | .70  | .002 | 188         | 1.53 | .008 | 106         | 2.73 | .026 | 65          | 4.07 | .063 |             |      |      |             |      |      |  |
| 3D5A             |            |     |      | 525        | .55 | .001 | 336         | .86  | .003 | 233         | 1.24 | .005 | 119         | 2.01 | .017 | 76          | 3.14 | .041 |             |      |      |             |      |      |  |
| 7D6A             |            |     |      |            |     |      |             |      |      | 229         | 1.00 | .004 | 116         | 1.60 | .014 | 75          | 2.50 | .033 |             |      |      |             |      |      |  |
| 3D4A             |            |     |      |            |     |      |             |      |      | 152         | 1.61 | .011 | 82          | 2.74 | .033 | 52          | 4.27 | .082 |             |      |      |             |      |      |  |
| 745A             |            |     |      |            |     |      |             |      |      | 155         | 1.15 | .007 | 79          | 1.85 | .023 | 51          | 2.89 | .057 |             |      |      |             |      |      |  |
| 1D6A             |            |     |      |            |     |      |             |      |      | 154         | 1.00 | .006 | 78          | 1.61 | .021 | 50          | 2.51 | .050 |             |      |      |             |      |      |  |
| 3D5A             |            |     |      |            |     |      |             |      |      | 233         | 1.24 | .005 | 119         | 2.01 | .017 | 76          | 3.14 | .041 |             |      |      |             |      |      |  |
| 7D6A             |            |     |      |            |     |      |             |      |      | 229         | 1.00 | .004 | 116         | 1.60 | .014 | 75          | 2.50 | .033 |             |      |      |             |      |      |  |
| 5D5A             |            |     |      |            |     |      |             |      |      | 290         | 1.35 | .005 | 156         | 2.30 | .015 | 100         | 3.59 | .036 |             |      |      |             |      |      |  |
| 7D6A             |            |     |      |            |     |      |             |      |      | 284         | 1.09 | .004 | 158         | 1.94 | .012 | 101         | 3.02 | .030 |             |      |      |             |      |      |  |
| 9D6A             |            |     |      |            |     |      |             |      |      | 412         | 1.22 | .003 | 214         | 2.00 | .009 | 131         | 3.01 | .023 | 68          | 3.23 | .048 |             |      |      |  |
| 7G6A             |            |     |      |            |     |      |             |      |      | 451         | 1.20 | .003 | 253         | 2.14 | .008 | 162         | 3.35 | .020 | 112         | 4.79 | .043 | 104         | 5.24 | .050 |  |

**Note:** To convert 1.5 safety factor to 2.0 multiply w,d,k by .75.

W=Pounds per linear foot

Metric: for kg/m multiply w by 1.48

d=Deflection (inches)

k= Deflection (in.) for each pound of load

†= Denotes k is less than .001 inch

# HAT CABLE TRAY SYSTEM



## SELECTION CHART: Steel Tray

### NEMA CLASS, PHYSICAL AND STRUCTURAL PROPERTIES

| NEMA Standard VE-1 Load/Span Class  | NEMA Load/Span          | Mill Galv. System Number | HDGAF System Number | Type 304 SS System Number | Nominal Load Depth |         | Side Rail Height |         | Flange Width (in.) | Section Modulus of 2 Rails Sx (in. <sup>3</sup> ) | Moment of Inertia for 2 Rails Ix (in. <sup>4</sup> ) | Min. X-Sect. Area of 2 Rails per NEC 392-7 (in. <sup>2</sup> ) |
|---|-------------------------|--------------------------|---------------------|---------------------------|--------------------|---------|------------------|---------|--------------------|---|--|--|
|   |                         |                          |                     |                           |                    |         |                  |         |                    |   |  |  |
| 8A-12A  | 50 lb./ft.<br>12' span  | 823P                     | 623G                | 823S                      | 3"                 | (76mm)  | 3 1/2"           | (89mm)  | 13/16"             | 0.444   | 0.778  | .40  |
|   |                         | 824P                     | 624G                | 824S                      | 4"                 | (102mm) | 4 1/4"           | (108mm) | 13/16"             | 0.592   | 1.258  | .40  |
|   |                         | 825P                     | 625G                | 825S                      | 5"                 | (127mm) | 5 1/4"           | (133mm) | 13/16"             | 0.816   | 2.142  | .40  |
|   |                         | 826P                     | 626G                | 826S                      | 6"                 | (152mm) | 6 1/4"           | (159mm) | 13/16"             | 1.072   | 3.352  | .70  |
| 12B   | 75 lb./ft.<br>12' span  | 423P                     | 423G                | 423S                      | 3"                 | (76mm)  | 3 1/2"           | (89mm)  | 13/16"             | 0.674   | 1.180  | .70  |
|   |                         | 8B4P                     | 6B4G                | 8B4S                      | 4"                 | (102mm) | 4 1/4"           | (108mm) | 13/16"             | 0.678   | 1.370  | .40  |
|   |                         | 825P                     | 625G                | 825S                      | 5"                 | (127mm) | 5 1/4"           | (133mm) | 13/16"             | 0.816   | 2.142  | .40  |
|   |                         | 826P                     | 626G                | 826S                      | 6"                 | (152mm) | 6 1/4"           | (159mm) | 13/16"             | 1.072   | 3.352  | .70  |
| 12C   | 100 lb./ft.<br>12' span | 6B4P                     | 6B4G                | 6B4S                      | 4"                 | (102mm) | 4 1/4"           | (108mm) | 13/16"             | 0.834   | 1.690  | .70  |
|   |                         | 6B5P                     | 6B5G                | 6B5S                      | 5"                 | (127mm) | 5 1/4"           | (133mm) | 13/16"             | 1.140   | 2.872  | .70  |
|   |                         | 626P                     | 626G                | 626S                      | 6"                 | (152mm) | 6 1/4"           | (159mm) | 13/16"             | 1.330   | 4.158  | .70  |
| 16A   | 50 lb./ft.<br>16' span  | 8D4P                     | 6D4G                | 8D4S                      | 4"                 | (102mm) | 4 1/4"           | (108mm) | 13/16"             | 0.852   | 1.736  | .40  |
|   |                         | 645P                     | 645G                | 645S                      | 5"                 | (127mm) | 5 1/4"           | (133mm) | 1 1/4"             | 1.280   | 3.360  | .70  |
|   |                         | 646P                     | 646G                | 646S                      | 6"                 | (152mm) | 6 1/4"           | (159mm) | 1 1/4"             | 1.652   | 5.160  | .70  |
| 16B   | 75 lb./ft.<br>16' span  | 6D4P                     | 6D4G                | 6D4S                      | 4"                 | (102mm) | 4 1/4"           | (108mm) | 1 1/4"             | 1.056   | 2.152  | .70  |
|   |                         | 645P                     | 645G                | 645S                      | 5"                 | (127mm) | 5 1/4"           | (133mm) | 1 1/4"             | 1.280   | 3.360  | .70  |
|   |                         | 646P                     | 646G                | 646S                      | 6"                 | (152mm) | 6 1/4"           | (159mm) | 1 1/4"             | 1.652   | 5.160  | .70  |
| 16C   | 100 lb./ft.<br>16' span | 4D4P                     | 4D4G                | 4D4S                      | 4"                 | (102mm) | 4 1/4"           | (108mm) | 1 1/4"             | 1.298   | 2.652  | 1.00   |
|   |                         | 645P                     | 645G                | 645S                      | 5"                 | (127mm) | 5 1/4"           | (133mm) | 1 1/4"             | 1.280   | 3.360  | .70  |
|   |                         | 646P                     | 646G                | 646S                      | 6"                 | (152mm) | 6 1/4"           | (159mm) | 1 1/4"             | 1.652   | 5.160  | .70  |
| 20A   | 50 lb./ft.<br>20' span  | 6D4P                     | 6D4G                | 6D4S                      | 4"                 | (102mm) | 4 1/4"           | (108mm) | 1 1/4"             | 1.056   | 2.152  | .70  |
|   |                         | 645P                     | 645G                | 645S                      | 5"                 | (127mm) | 5 1/4"           | (133mm) | 1 1/4"             | 1.280   | 3.360  | .70  |
|   |                         | 646P                     | 646G                | 646S                      | 6"                 | (152mm) | 6 1/4"           | (159mm) | 1 1/4"             | 1.652   | 5.160  | 1.00   |
| 20B   | 75 lb./ft.<br>20' span  | 2D4P                     | 2D4G                | 2D4S                      | 4"                 | (102mm) | 4 1/4"           | (108mm) | 1 1/4"             | 1.758   | 3.604  | 1.00   |
|   |                         | 4D5P                     | 4D5G                | 4D5S                      | 5"                 | (127mm) | 5 1/4"           | (133mm) | 1 1/4"             | 1.744   | 4.418  | 1.00   |
|   |                         | 6D6P                     | 6D6G                | 6D6S                      | 6"                 | (152mm) | 6 1/4"           | (159mm) | 1 1/4"             | 1.814   | 5.486  | 1.00   |
| 20C   | 100 lb./ft.<br>20' span | 2D5P                     | 2D5G                | 2D5S                      | 5"                 | (127mm) | 5 1/4"           | (133mm) | 1 1/4"             | 2.370   | 6.026  | 1.50   |
|   |                         | 4D6P                     | 4D6G                | 4D6S                      | 6"                 | (143mm) | 6 1/4"           | (159mm) | 1 1/4"             | 2.240   | 6.778  | 1.00   |
| <b>EXTRA HEAVY DUTY - VERY LONG SPAN TRAYS- 4", 6" OR 9" RUNG SPACING</b> |                         |                          |                     |                           |                    |         |                  |         |                    |   |  |  |
|   |                         | 2D6P                     | 2D6G                | 2D6S                      | 6"                 | (152mm) | 6 1/4"           | (159mm) | 1 1/4"             | 3.052   | 9.270  | 1.50   |
|   |                         | 11D6P                    | 11D6G               | 11D6S                     | 6"                 | (152mm) | 6 1/4"           | (159mm) | 1 1/4"             | 3.536   | 10.630   | 1.50   |

**Note:**   indicates most common systems. Consult factory for lead times on other systems.

**Slotted Rungs** provided on trays 6", 9", 12", 18" and 24" wide.

**Solid Rungs** provided on trays 30" and 36" wide.

**LOAD AND DEFLECTION DATA FOR STEEL HAT**  
Working (Allowable) Load Capacity, Evenly Distributed-Tested per NEMA Standard VE-1,  
Simple Beam - SAFETY FACTOR 1.5

| Cope<br>Sys. No. | 6 Ft. Span |     |      | 8 Ft. Span |     |      | 10 Ft. Span |     |      | 12 Ft. Span |      |      | 16 Ft. Span |      |      | 20 Ft. Span |      |      | 24 Ft. Span |      |      | 25 Ft. Span |      |      |
|------------------|------------|-----|------|------------|-----|------|-------------|-----|------|-------------|------|------|-------------|------|------|-------------|------|------|-------------|------|------|-------------|------|------|
|                  | w          | d   | k    | w          | d   | k    | w           | d   | k    | w           | d    | k    | w           | d    | k    | w           | d    | k    | w           | d    | k    | w           | d    | k    |
| 823P/G/S         | 230        | .30 | .001 | 126        | .52 | .004 | 79          | .79 | .010 | 53          | 1.11 | .021 |             |      |      |             |      |      |             |      |      |             |      |      |
| 824P/G/S         | 292        | .23 | †    | 164        | .42 | .003 | 103         | .63 | .006 | 69          | .89  | .013 |             |      |      |             |      |      |             |      |      |             |      |      |
| 825P/G/S         | 383        | .18 | †    | 210        | .31 | .001 | 127         | .46 | .004 | 83          | .62  | .007 |             |      |      |             |      |      |             |      |      |             |      |      |
| 826P/G/S         | 357        | .11 | †    | 194        | .18 | †    | 119         | .28 | .002 | 79          | .38  | .005 |             |      |      |             |      |      |             |      |      |             |      |      |
| 423P/G/S         | 358        | .30 | †    | 197        | .53 | .003 | 124         | .81 | .007 | 83          | 1.13 | .014 |             |      |      |             |      |      |             |      |      |             |      |      |
| 8B4P/G/S         | 360        | .26 | †    | 198        | .46 | .002 | 124         | .70 | .006 | 84          | .98  | .012 |             |      |      |             |      |      |             |      |      |             |      |      |
| 825P/G/S         | 383        | .18 | †    | 210        | .31 | .001 | 127         | .46 | .004 | 83          | .62  | .007 |             |      |      |             |      |      |             |      |      |             |      |      |
| 826P/G/S         | 357        | .11 | †    | 194        | .18 | †    | 119         | .28 | .002 | 79          | .38  | .005 |             |      |      |             |      |      |             |      |      |             |      |      |
| 6B4P/G/S         | 453        | .27 | †    | 249        | .47 | .002 | 156         | .71 | .005 | 106         | 1.00 | .009 |             |      |      |             |      |      |             |      |      |             |      |      |
| 6B5P/G/S         | 591        | .21 | †    | 325        | .36 | .001 | 203         | .55 | .003 | 137         | .77  | .006 |             |      |      |             |      |      |             |      |      |             |      |      |
| 626P/G/S         | 460        | .11 | †    | 250        | .19 | †    | 154         | .29 | .002 | 103         | .40  | .004 |             |      |      |             |      |      |             |      |      |             |      |      |
| 8D4P/G/S         |            |     |      | 290        | .53 | .002 | 182         | .81 | .004 | 126         | 1.17 | .009 | 65          | 1.91 | .029 |             |      |      |             |      |      |             |      |      |
| 645P/G/S         |            |     |      | 444        | .42 | †    | 273         | .63 | .002 | 186         | .89  | .005 | 100         | 1.51 | .015 |             |      |      |             |      |      |             |      |      |
| 646P/G/S         |            |     |      | 574        | .42 | †    | 367         | .55 | .001 | 245         | .76  | .003 | 123         | 1.22 | .010 |             |      |      |             |      |      |             |      |      |
| 6D4P/G/S         |            |     |      | 381        | .56 | .001 | 244         | .88 | .004 | 169         | 1.27 | .008 | 88          | 2.08 | .024 |             |      |      |             |      |      |             |      |      |
| 645P/G/S         |            |     |      | 444        | .42 | †    | 273         | .63 | .002 | 186         | .89  | .005 | 100         | 1.51 | .015 |             |      |      |             |      |      |             |      |      |
| 646P/G/S         |            |     |      | 574        | .42 | †    | 367         | .55 | .001 | 245         | .76  | .003 | 123         | 1.22 | .010 |             |      |      |             |      |      |             |      |      |
| 4D4P/G/S         |            |     |      | 487        | .58 | .001 | 312         | .91 | .003 | 216         | 1.31 | .006 | 113         | 2.16 | .019 |             |      |      |             |      |      |             |      |      |
| 645P/G/S         |            |     |      | 444        | .42 | †    | 273         | .63 | .002 | 186         | .89  | .005 | 100         | 1.51 | .015 |             |      |      |             |      |      |             |      |      |
| 646P/G/S         |            |     |      | 574        | .42 | †    | 367         | .55 | .001 | 245         | .76  | .003 | 123         | 1.22 | .010 |             |      |      |             |      |      |             |      |      |
| 6D4P/G/S         |            |     |      |            |     |      |             |     |      | 169         | 1.27 | .008 | 88          | 2.08 | .024 | 52          | 2.98 | .057 |             |      |      |             |      |      |
| 645P/G/S         |            |     |      |            |     |      |             |     |      | 186         | .89  | .005 | 100         | 1.51 | .015 | 53          | 1.94 | .037 |             |      |      |             |      |      |
| 646P/G/S         |            |     |      |            |     |      |             |     |      | 245         | .76  | .003 | 123         | 1.22 | .010 | 66          | 1.59 | .024 |             |      |      |             |      |      |
| 2D4P/G/S         |            |     |      |            |     |      |             |     |      | 304         | 1.36 | .004 | 159         | 2.24 | .014 | 94          | 3.23 | .034 |             |      |      |             |      |      |
| 4D5P/G/S         |            |     |      |            |     |      |             |     |      | 280         | 1.02 | .004 | 145         | 1.67 | .012 | 85          | 2.40 | .028 |             |      |      |             |      |      |
| 6D6P/G/S         |            |     |      |            |     |      |             |     |      | 269         | .80  | .003 | 139         | 1.28 | .009 | 81          | 1.82 | .022 |             |      |      |             |      |      |
| 2D5P/G/S         |            |     |      |            |     |      |             |     |      | 395         | 1.05 | .003 | 206         | 1.74 | .008 | 121         | 2.50 | .021 |             |      |      |             |      |      |
| 4D6P/G/S         |            |     |      |            |     |      |             |     |      | 296         | .79  | .003 | 152         | 1.28 | .008 | 105         | 1.91 | .018 |             |      |      |             |      |      |
| 2D6P/G/S         |            |     |      |            |     |      |             |     |      | 300         | .85  | .002 | 221         | 1.40 | .006 | 149         | 2.00 | .013 | 79          | 1.91 | .024 | 73          | 2.38 | .033 |
| 11D6P/G/S        |            |     |      |            |     |      |             |     |      | 434         | .66  | †    | 244         | 1.17 | .005 | 156         | 1.82 | .012 | 108         | 2.62 | .024 | 100         | 2.85 | .029 |

Note: To convert 1.5 safety factor to 2.0 multiply w, d, k by .75

W=Pounds per linear foot

Metric: for kg/m multiply w by 1.48

d=Deflection (inches)

k= Deflection (in.) for each pound of load

†= Denotes k is less than .001 inch

# HAT CABLE TRAY SYSTEM

## OVERVIEW

**AB-COPE HAT** is a prefabricated metal structure consisting of reinforced hat-shaped rungs, arc-welded to the side rails, and is manufactured to NEMA Standard VE-1. Cope Hat rungs are fastened to the side rails with an automatic, self-indexing MIG-arc-welding system, plug welding a 1/2" diameter zone. The superior strength of the AB-Cope plug weld withstands the rigors of shipping, handling, erection and cable support service.

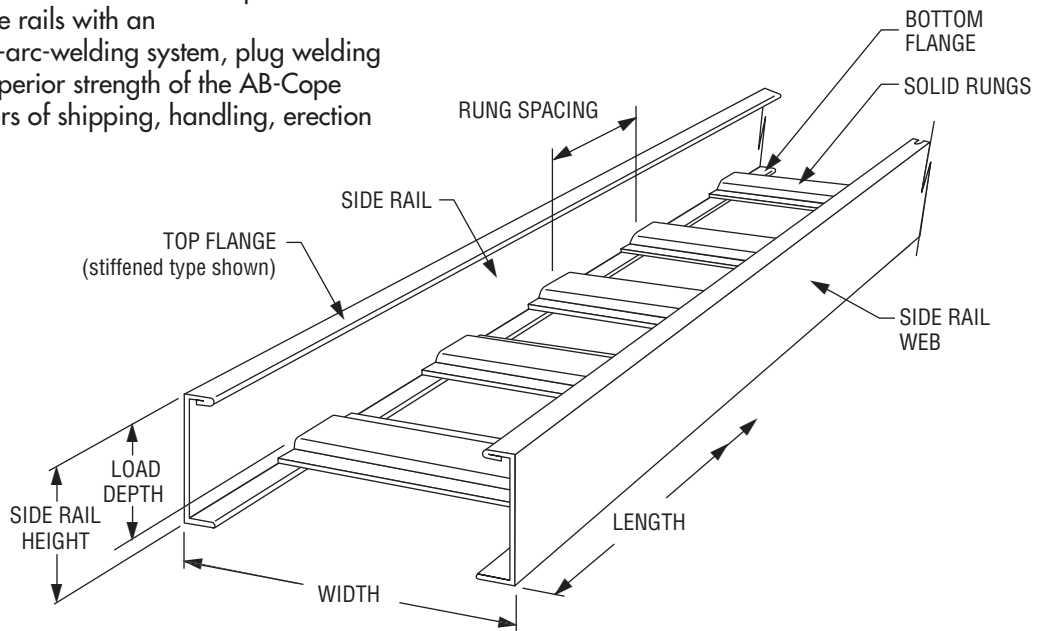

**Side Members** - AB-Cope Hat side members are designed with top and bottom flanges turned inward. This minimizes the space requirements of the cable tray system, and allows a very low side rail height for each NEMA Standard VE-1 load depth.

**Rungs** - AB-Cope Hat provides for hat shaped rungs.

**SOLID RUNGS** — Solid Hat shaped Rungs are standard on all tray widths.

Solid Hat Rungs for Steel trays are Hat shaped, 2 1/4" wide and provide for a 7/8" cable bearing surface.

Solid Hat Rungs for Aluminum trays are Hat shaped, 3 1/4" wide and provide for a 1 1/2" cable bearing surface.

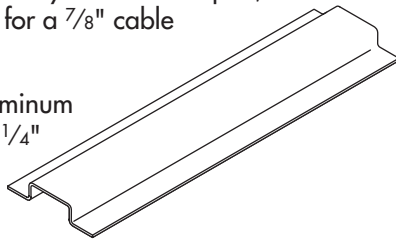

**SLOTTED RUNGS** — are offered as a special order. Please contact AB-Cope for more information

**Rung Spacing** — AB-Cope manufactures straight lengths with four standard rung spacings; 6", 9", 12", and 18". The 6" rung spacing results in a 3 3/4" opening between rungs allowing the tray to be classified as a ventilated trof per NEMA Standard VE-1.

**Length** — The longitudinal dimensions of standard AB-Cope Hat cable tray are 10', 12', 20', and 24'.

**Width** — The transverse dimensions of AB-Cope Hat cable tray are measured inside, (from side member web to side member web), and are furnished in seven standard widths: 6", 9", 12", 18", 24", 30" and 36".

**Overall Width** — Overall tray width is equal to the inside or nominal width plus the thickness of the two side rail webs.

$$\text{Overall Tray Width} = \text{Nominal} + \frac{3}{16}'' \text{ Width}$$

**Load Depth** — Measured from the top surface of the rungs to the top of the side member. AB-Cope manufactures four loading depths; 2 7/8", 3 5/8", 4 5/8", and 5 5/8" corresponding to the four nominal loading depths in NEMA Standard VE-1; 3", 4", 5" and 6".

**Overall Height** — AB-Cope Hat cable tray overall height is equal to the loading depth plus 5/8".

**Fittings** — For changing direction both horizontally and vertically, AB-Cope manufactures elbows, tees, and crosses in all widths and loading depths. Fittings are available in three standard radii; 12", 24", and 36". Standard fittings maintain a nominal 9" rung spacing through the centerline of the fitting. AB-Cope manufactures all standard fittings with zero tangents.

## AB-COPE HAT CABLE TRAY WITH FOUR IMPORTANT INDUSTRY-LEADING FEATURES:

### 1. Compact Economical System –

Hat cable tray is an extremely compact economical flange in cable tray system which allows the designer to utilize this cable tray in tight locations. The extremely low profile Hat Rungs ( $\frac{5}{8}$ " high) minimize the required side rail height while maintaining NEMA Standard VE-1 nominal load depths. Overall system height is only  $\frac{5}{8}$ " greater than the actual loading depth.

### 2. Universal Curvilinear Splice Plate System –

The splice plates for rigid connections have a slight curve so they can be used on straight sections or fittings. Tightening of the fastener pulls the plate flush with the side rail. The fasteners are snug and the joint is superior structurally and electrically. Even when hand-tightened, there is pressure on the fastener to hold it securely.

**Note:** Heavy Duty, Mid Span Splice Plates available upon request.

### 3. Zero Tangent Fittings –

Tangent as referred to on cable tray fittings is the straight at the end of the curve to accommodate a flat splice plate. This wastes space in tightly packed areas, such as spreader rooms, where the heat of thousands of cables accumulate. Eliminating tangents allow more tray runs to distribute the heat.

AB-COPE ZERO TANGENT FITTINGS CAN SAVE UP TO 12" PER ROW OF TRAY.

**BONUS:** Inspection for proper installation of splice plate is visual. If the plate is bowed away from the rail, nuts must be tightened.

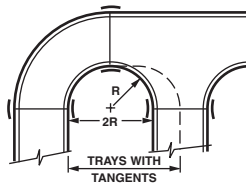

### 4. The Exclusive Auto MIG-Arc-Welded Assembly System –

Hat rungs on straight sections are assembled to the side rails using an automatic, self indexing MIG-arc-welding system fusing a  $\frac{1}{2}$ " diameter zone. These welds are 700% larger and stronger than the common resistance (spot) weld in use today. Electrical properties of the assembly are unequalled; are well within the NEMA requirements due to the continuous electrical path. The mechanical strength of this welded assembly withstands the rigors of shipping, handling, installation, and service. The size of the weld keeps the vertical axis of the side rail from sloping inward under load. The weld maintains the  $90^\circ$  angle between the side rail and bottom. This allows full use of the section properties. Spot welds do not permit this. Also, stresses on spot welds (barely  $\frac{1}{8}$ " in diameter) are so severe that breakage often occurs during shipping and installation. AB-Cope Hat fittings are also assembled by MIG-arc welding.

# HAT CABLE TRAY SYSTEM

## PART NUMBERING SYSTEM:

Please pay careful attention to the part numbering structure. Example: Catalog No. 1B4A-06SL-12-09 is a 4" load depth aluminum ladder with a 13/16" flange, 6 inches wide, straight length 12 feet long, rungs on 9" centers. Please make sure you use the system numbers from pages 103 through 106 when ordering.

### Straight Length

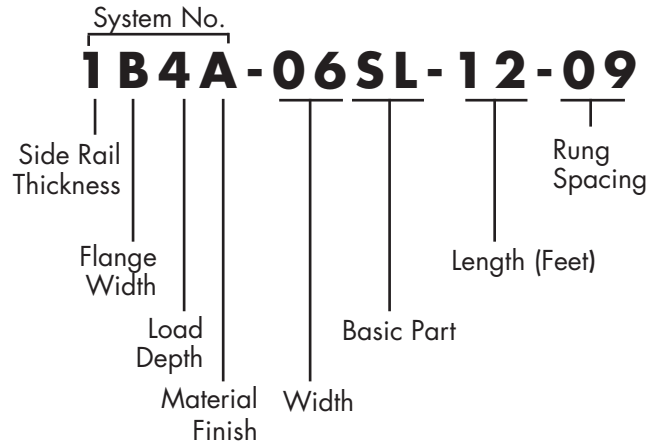

### Fittings

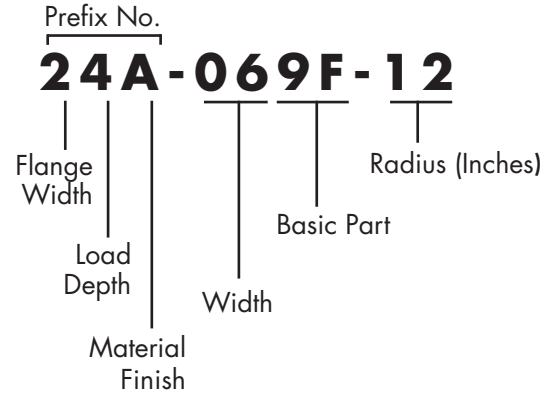

### SYSTEM NUMBER (STRAIGHT SECTION ONLY)

– The first four digits make up the system number which identifies the structural, dimensional, and material characteristics of the straight length. It is made up of the side rail digits indicating the side rail thickness and flange width, the load depth (inside, in inches) and material finish (galvanized, aluminum or coated).

**PREFIX NUMBER (FITTINGS ONLY)** – Fittings are ordered using the 3-digit prefix number given in the charts on the fitting pages. Fittings do not have stiffened upper flanges.

| Thickness Steel (Ga.) | Flange Width      | Load Depth | Material Finish |
|-----------------------|-------------------|------------|-----------------|
| 8 - 18 ga.            | 2 - 13/16" (21mm) | 3" (76mm)  | P - Mill-Galv.  |
| 6 - 16 ga.            | 4 - 1 1/4" (32mm) | 4" (102mm) | G - HDGAF       |
| 4 - 14 ga.            | 7 - 2" (51mm)     | 5" (127mm) | A - Aluminum    |
| 2 - 12 ga.            |                   | 6" (152mm) | S - 304SS       |
| 11 - 11 ga.           |                   |            |                 |
| Thickness Alum (in.)  |                   |            |                 |
| 1 - Thinner           | B - 13/16" (21mm) |            |                 |
| 3 -                   | D - 1 1/4" (32mm) |            |                 |
| 5 - ** ↓              | G - 2" (51mm)     |            |                 |
| 7 -                   |                   |            |                 |
| 9 - Thicker           |                   |            |                 |

\*\*Alum. extruded side rails are individually engineered to loads and spans.

**Slotted Rungs** provided on trays 6", 9", 12", 18" and 24" wide

**Solid Rungs** provided on trays 30" and 36" wide.

Identifies the inside width of the tray in inches.

**BASIC PART NUMBER** – Identifies the straight length, fitting, or accessory.

**SECONDARY DIMENSION NUMBER** – Identifies the length of a straight section in feet, the radius of a fitting in inches, or the second width of a reducer in inches.

**RUNG SPACING** – Identifies the center-to-center distance between rungs on straight length. Nominal 9" (229mm) rung spacing maintained through centerline of all fittings.

| Description     |                                |              |                 |
|-----------------|--------------------------------|--------------|-----------------|
| Width (in.)     | Basic Part Number              | Length       | Rung Spacing    |
| -06=6" (152mm)  | SL (Straight Len.)             | - 12' (3.7m) | 06=6" (152mm)   |
| -09=9" (229mm)  | 9F (90° Horiz. El.)            | - 24' (7.3m) | 09=9" (229mm)   |
| -12=12" (305mm) | 6F (60° Horiz. El.)            | - 10' (3m)   | 12=12" (305mm)  |
| -18=18" (457mm) | 4F (45° Horiz. El.)            | - 20' (6m)   | 18=18" (457mm)  |
| -24=24" (610mm) | 3F (30° Horiz. El.)            |              |                 |
| -30=30" (762mm) | 90 (90° Out. Vert.El.)         |              |                 |
| -36=36" (914mm) | 60 (60° Out. Vert. El.)        |              |                 |
|                 | 40 (45° Out. Vert. El.)        |              |                 |
|                 | 30 (30° Out. Vert. El.)        |              |                 |
|                 | 9I (90° In. Vert. El.)         |              |                 |
|                 | 6I (60° In. Vert. El.)         |              |                 |
|                 | 4I (45° In. Vert. El.)         |              |                 |
|                 | 3I (30° In. Vert. El.)         |              |                 |
|                 | FT (Horiz. Tee)                |              |                 |
|                 | FC (Horiz. Cross)              |              |                 |
|                 | VT (Vert. Tee)                 |              |                 |
|                 | SR (Vert. Cable Support Elbow) |              |                 |
|                 | ST (Straight Reducer)          |              |                 |
|                 | RH (Right Hand Reducer)        |              |                 |
|                 | LH (Left Hand Reducer)         |              |                 |
|                 | AF (Adjustable Elbow)          |              |                 |
|                 | RY & LY (45° Y-Branch)         |              |                 |
|                 |                                |              | Radius (in.)    |
|                 |                                |              | -12=12" (205mm) |
|                 |                                |              | -24=24" (610mm) |
|                 |                                |              | -36=36" (914mm) |

## Straight Length [SL]

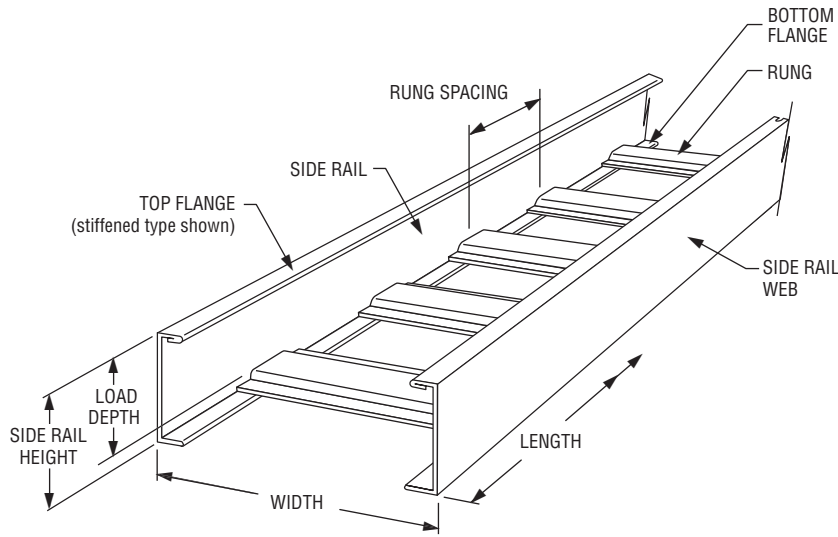

| Catalog Number      |             |           |              |              |
|---------------------|-------------|-----------|--------------|--------------|
| System              | Basic Width | Basic No. | Length (ft.) | Rung Spacing |
| See Pages 102 – 105 | -06         | SL        | -10          | -04          |
|                     | -09         |           | -12          | -06          |
|                     | -12         |           | -20          | -09          |
|                     | -18         |           | -24          | -12          |
|                     | -24         |           |              | -18          |
|                     | -30         |           |              |              |
|                     | -36         |           |              |              |

**EXAMPLE:** 1B4A-06SL-12-09 is a 4" load depth aluminum Hat with a 13/16" flange, 6" wide, 12' long, with 9" rung spacing.

AB-Cope Hat cable tray is manufactured in 10', 12', 20' and 24' lengths; 6", 9", 12", 18", 24", 30" and 36" widths and 3", 4", 5", and 6" nominal load depths. Sufficient connectors are supplied to assemble straight sections and fittings for each other. Connectors for field cuts must be ordered separately.

| Conversion Table |     |     |     |     |     |     |     |      |      |     |     |
|------------------|-----|-----|-----|-----|-----|-----|-----|------|------|-----|-----|
| English          | 6"  | 9"  | 12" | 18" | 24" | 30" | 36" | 12'  | 24'  | 10' | 20' |
| Metric (mm)      | 152 | 229 | 305 | 457 | 610 | 762 | 914 | 3.7m | 7.3m | 3m  | 6m  |

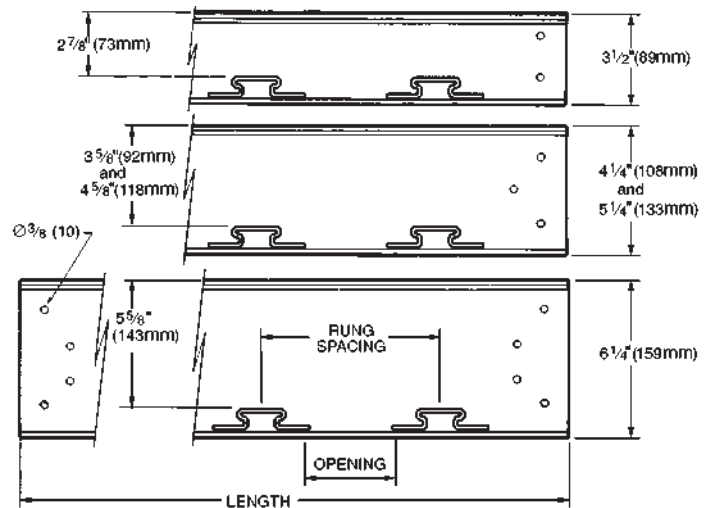
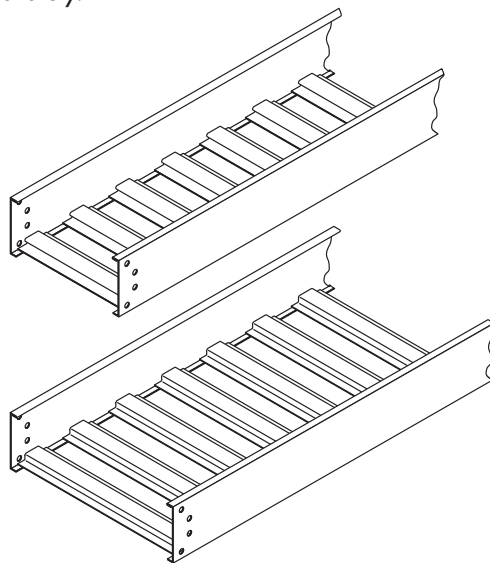

### MATERIAL & FINISH SPECIFICATIONS (Ladder Cable Tray)

|                            | Pre-Galvanized Steel   | Hot-Dip Galvanized after Fabrication ASTM A-123          | Aluminum                                 | Type 304 Stainless Steel                    |
|----------------------------|--|--|--|---|
| <b>Siderails</b>           | ASTM A-653-G90 CS (18 & 16 Gage)<br>ASTM A-653-G90 CS (14 & 12 Gage) | ASTM A-1008 (18 & 16 Gage)<br>ASTM A-1011 (14 & 12 Gage) | AA-6063-T6 Extruded                      | ASTM A-240; Type 304                        |
| <b>Rungs</b>               | ASTM A-653-G90 CS  | ASTM A-1008  | AA-6063-H34                              | ASTM A-269; Type 304                        |
| <b>Splice Plate Finish</b> | ASTM A-1011<br>ASTM A-591 Class C                                    | ASTM A-1011<br>ASTM A-123 Grade 65                       | AA-5052-H34                              | ASTM A-240; Type 304<br>2B Finish (Typical) |
| <b>Connector Bolts</b>     | SAE J429 Grade 1<br>(ASTM A-307 Grade A)                             | SAE J429 Grade 1<br>(ASTM A-307 Grade A)                 | SAE J429 Grade 1<br>(ASTM A-307 Grade A) | AISI Type 304 Stainless Steel               |
| <b>Bolt Plating</b>        | ASTM B-633.0002" Zinc  | ASTM B-633.0002" Zinc                                    | ASTM B-633.0002" Zinc                    |   |
| <b>Covers</b>              | ASTM A-653-G90 CQ  | ASTM A-653-G90 CQ  | AA-3003 H14 or 3150 H14                  | ASTM A-240; Type 304                        |

# HAT CABLE TRAY SYSTEM

## 90° Horizontal Elbow [9F]

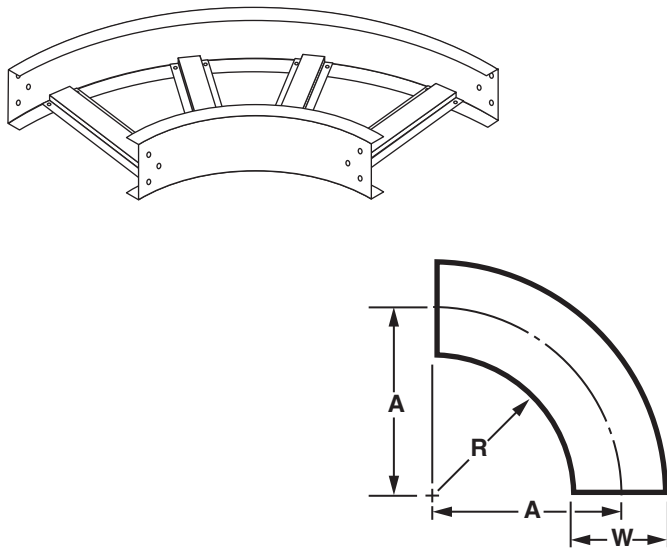

**CSA Compliance for CSA Systems**

| Radius - R            | Width - W    | "A" Dimension    |
|-----------------------|--------------|------------------|
| <b>12"</b><br>(305mm) | 6" (152mm)   | 15" (381mm)      |
|                       | 9" (229mm)   | 16 1/2" (419mm)  |
|                       | 12" (305mm)  | 18" (457mm)      |
|                       | 18" (457mm)  | 21" (533mm)      |
|                       | 24" (610mm)  | 24" (610mm)      |
|                       | 30" (762mm)  | 27" (686mm)      |
| <b>24"</b><br>(610mm) | 36" (914mm)  | 30" (762mm)      |
|                       | 6" (152mm)   | 27" (686mm)      |
|                       | 9" (229mm)   | 28 1/2" (724mm)  |
|                       | 12" (305mm)  | 30" (762mm)      |
|                       | 18" (457mm)  | 33" (838mm)      |
|                       | 24" (610mm)  | 36" (914mm)      |
| <b>36"</b><br>(914mm) | 30" (762mm)  | 39" (991mm)      |
|                       | 36" (914mm)  | 42" (1067mm)     |
|                       | 6" (152mm)   | 39" (991mm)      |
|                       | 9" (229mm)   | 40 1/2" (1029mm) |
|                       | 12" (305mm)  | 42" (1067mm)     |
|                       | 18" (457mm)  | 45" (1143mm)     |
| 24" (610mm)           | 48" (1219mm) |                  |
| 30" (762mm)           | 51" (1295mm) |                  |
| 36" (914mm)           | 54" (1372mm) |                  |

EXAMPLE: 24A-129F-12

## 60° Horizontal Elbow [6F]

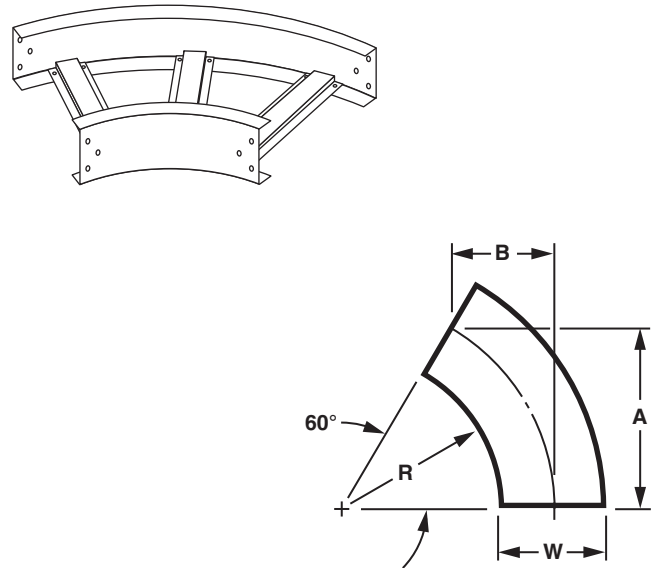

**CSA Compliance for CSA Systems**

| Radius - R            | Width - W        | "A" Dimension   | "B" Dimension   |
|-----------------------|------------------|-----------------|-----------------|
| <b>12"</b><br>(305mm) | 6" (152mm)       | 13" (330mm)     | 7 1/2" (191mm)  |
|                       | 9" (229mm)       | 14 1/4" (362mm) | 8 1/4" (210mm)  |
|                       | 12" (305mm)      | 15 5/8" (397mm) | 9" (229mm)      |
|                       | 18" (457mm)      | 18 1/4" (464mm) | 10 1/2" (267mm) |
|                       | 24" (610mm)      | 20 3/4" (527mm) | 12" (305mm)     |
|                       | 30" (762mm)      | 23 3/8" (594mm) | 13 1/2" (343mm) |
| <b>24"</b><br>(610mm) | 36" (914mm)      | 26" (660mm)     | 15" (381mm)     |
|                       | 6" (152mm)       | 23 3/8" (594mm) | 13 1/2" (343mm) |
|                       | 9" (229mm)       | 24 3/4" (629mm) | 14 1/4" (362mm) |
|                       | 12" (305mm)      | 26" (660mm)     | 15" (381mm)     |
|                       | 18" (457mm)      | 28 5/8" (727mm) | 16 1/2" (416mm) |
|                       | 24" (610mm)      | 31 1/4" (794mm) | 18" (457mm)     |
| <b>36"</b><br>(914mm) | 30" (762mm)      | 33 3/4" (857mm) | 19 1/2" (495mm) |
|                       | 36" (914mm)      | 36 3/8" (924mm) | 21" (533mm)     |
|                       | 6" (152mm)       | 33 3/4" (857mm) | 19 1/2" (495mm) |
|                       | 9" (229mm)       | 35 1/8" (892mm) | 20 1/4" (514mm) |
|                       | 12" (305mm)      | 36 3/8" (924mm) | 21" (533mm)     |
|                       | 18" (457mm)      | 39" (991mm)     | 22 1/2" (572mm) |
| 24" (610mm)           | 41 5/8" (1057mm) | 24" (610mm)     |                 |
| 30" (762mm)           | 44 1/8" (1121mm) | 25 1/2" (648mm) |                 |
| 36" (914mm)           | 46 3/4" (1187mm) | 27" (686mm)     |                 |

EXAMPLE: 24A-126F-12

### Ordering Information:

See Page 133  
for Electrical  
Grounding Chart

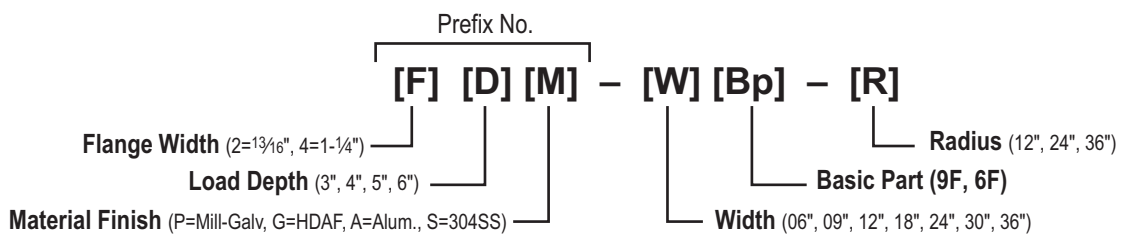

## 45° Horizontal Elbow [4F]

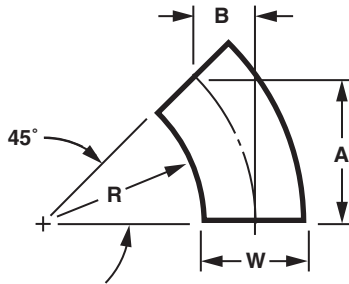
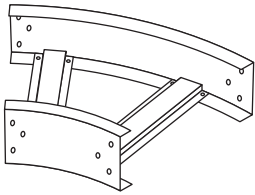

CSA Compliance for CSA Systems

| Radius - R     | Width - W   | "A" Dimension                            | "B" Dimension                            |
|----------------|-------------|--|--|
| 12"<br>(305mm) | 6" (152mm)  | 10 <sup>5</sup> / <sub>8</sub> " (270mm) | 4 <sup>3</sup> / <sub>8</sub> " (111mm)  |
|                | 9" (229mm)  | 11 <sup>5</sup> / <sub>8</sub> " (295mm) | 4 <sup>7</sup> / <sub>8</sub> " (124mm)  |
|                | 12" (305mm) | 12 <sup>3</sup> / <sub>4</sub> " (324mm) | 5 <sup>1</sup> / <sub>4</sub> " (133mm)  |
|                | 18" (457mm) | 14 <sup>7</sup> / <sub>8</sub> " (378mm) | 6 <sup>1</sup> / <sub>8</sub> " (156mm)  |
|                | 24" (610mm) | 17" (432mm)                              | 7" (178mm)                               |
|                | 30" (762mm) | 19 <sup>7</sup> / <sub>8</sub> " (486mm) | 7 <sup>7</sup> / <sub>8</sub> " (200mm)  |
| 24"<br>(610mm) | 36" (914mm) | 21 <sup>1</sup> / <sub>4</sub> " (540mm) | 8 <sup>3</sup> / <sub>4</sub> " (222mm)  |
|                | 6" (152mm)  | 19 <sup>1</sup> / <sub>8</sub> " (486mm) | 7 <sup>7</sup> / <sub>8</sub> " (200mm)  |
|                | 9" (229mm)  | 20 <sup>1</sup> / <sub>8</sub> " (511mm) | 8 <sup>3</sup> / <sub>8</sub> " (213mm)  |
|                | 12" (305mm) | 21 <sup>1</sup> / <sub>4</sub> " (540mm) | 8 <sup>3</sup> / <sub>4</sub> " (222mm)  |
|                | 18" (457mm) | 23 <sup>3</sup> / <sub>8</sub> " (594mm) | 9 <sup>5</sup> / <sub>8</sub> " (244mm)  |
|                | 24" (610mm) | 25 <sup>1</sup> / <sub>2</sub> " (648mm) | 10 <sup>1</sup> / <sub>2</sub> " (267mm) |
| 36"<br>(914mm) | 30" (762mm) | 27 <sup>5</sup> / <sub>8</sub> " (702mm) | 11 <sup>1</sup> / <sub>2</sub> " (292mm) |
|                | 36" (914mm) | 29 <sup>3</sup> / <sub>4</sub> " (756mm) | 12 <sup>3</sup> / <sub>8</sub> " (314mm) |
|                | 6" (152mm)  | 27 <sup>5</sup> / <sub>8</sub> " (702mm) | 11 <sup>1</sup> / <sub>2</sub> " (292mm) |
|                | 9" (229mm)  | 28 <sup>5</sup> / <sub>8</sub> " (727mm) | 11 <sup>7</sup> / <sub>8</sub> " (302mm) |
|                | 12" (305mm) | 29 <sup>3</sup> / <sub>4</sub> " (756mm) | 12 <sup>3</sup> / <sub>8</sub> " (314mm) |
|                | 18" (457mm) | 31 <sup>7</sup> / <sub>8</sub> " (810mm) | 13 <sup>1</sup> / <sub>4</sub> " (337mm) |
| 36"<br>(914mm) | 24" (610mm) | 34" (864mm)                              | 14 <sup>1</sup> / <sub>8</sub> " (359mm) |
|                | 30" (762mm) | 36 <sup>1</sup> / <sub>8</sub> " (918mm) | 15" (381mm)                              |
|                | 36" (914mm) | 38 <sup>1</sup> / <sub>4</sub> " (972mm) | 15 <sup>7</sup> / <sub>8</sub> " (403mm) |

EXAMPLE: 24A-124F-12

## 30° Horizontal Elbow [3F]

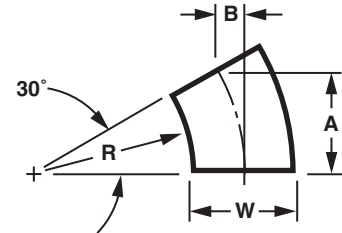
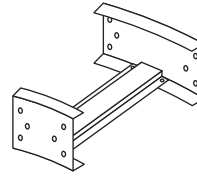

CSA Compliance for CSA Systems

| Radius - R     | Width - W   | "A" Dimension                            | "B" Dimension                           |
|----------------|-------------|--|---|
| 12"<br>(305mm) | 6" (152mm)  | 7 <sup>1</sup> / <sub>2</sub> " (191mm)  | 2" (51mm)                               |
|                | 9" (229mm)  | 8 <sup>1</sup> / <sub>4</sub> " (210mm)  | 2 <sup>1</sup> / <sub>4</sub> " (57mm)  |
|                | 12" (305mm) | 9" (229mm)                               | 2 <sup>3</sup> / <sub>8</sub> " (60mm)  |
|                | 18" (457mm) | 10 <sup>1</sup> / <sub>2</sub> " (267mm) | 2 <sup>7</sup> / <sub>8</sub> " (73mm)  |
|                | 24" (610mm) | 12" (305mm)                              | 3 <sup>1</sup> / <sub>4</sub> " (83mm)  |
|                | 30" (762mm) | 13 <sup>1</sup> / <sub>2</sub> " (343mm) | 3 <sup>5</sup> / <sub>8</sub> " (92mm)  |
| 24"<br>(610mm) | 36" (914mm) | 15" (381mm)                              | 4" (102mm)                              |
|                | 6" (152mm)  | 13 <sup>1</sup> / <sub>2</sub> " (343mm) | 3 <sup>5</sup> / <sub>8</sub> " (92mm)  |
|                | 9" (229mm)  | 14 <sup>1</sup> / <sub>4</sub> " (362mm) | 3 <sup>7</sup> / <sub>8</sub> " (98mm)  |
|                | 12" (305mm) | 15" (381mm)                              | 4" (102mm)                              |
|                | 18" (457mm) | 16 <sup>1</sup> / <sub>2</sub> " (419mm) | 4 <sup>3</sup> / <sub>8</sub> " (111mm) |
|                | 24" (610mm) | 18" (457mm)                              | 4 <sup>7</sup> / <sub>8</sub> " (124mm) |
| 36"<br>(914mm) | 30" (762mm) | 19 <sup>1</sup> / <sub>2</sub> " (495mm) | 5 <sup>1</sup> / <sub>4</sub> " (133mm) |
|                | 36" (914mm) | 21" (533mm)                              | 5 <sup>5</sup> / <sub>8</sub> " (143mm) |
|                | 6" (152mm)  | 19 <sup>1</sup> / <sub>2</sub> " (495mm) | 5 <sup>1</sup> / <sub>4</sub> " (133mm) |
|                | 9" (229mm)  | 20 <sup>1</sup> / <sub>4</sub> " (514mm) | 5 <sup>1</sup> / <sub>2</sub> " (140mm) |
|                | 12" (305mm) | 21" (533mm)                              | 5 <sup>5</sup> / <sub>8</sub> " (143mm) |
|                | 18" (457mm) | 22 <sup>1</sup> / <sub>2</sub> " (572mm) | 6" (152mm)                              |
| 36"<br>(914mm) | 24" (610mm) | 24" (610mm)                              | 6 <sup>1</sup> / <sub>2</sub> " (165mm) |
|                | 30" (762mm) | 25 <sup>1</sup> / <sub>2</sub> " (648mm) | 6 <sup>7</sup> / <sub>8</sub> " (175mm) |
|                | 36" (914mm) | 27" (686mm)                              | 7 <sup>1</sup> / <sub>4</sub> " (184mm) |

EXAMPLE: 24A-123F-12

### Ordering Information:

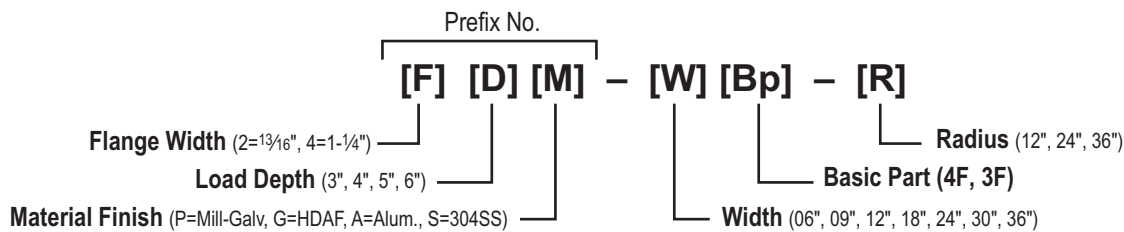

See Page 133  
for Electrical  
Grounding Chart

## Horizontal Tee [FT]

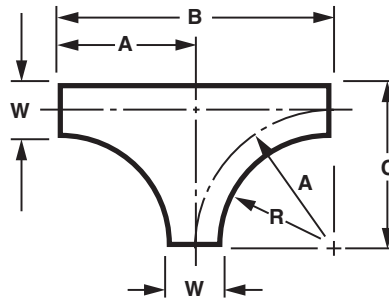
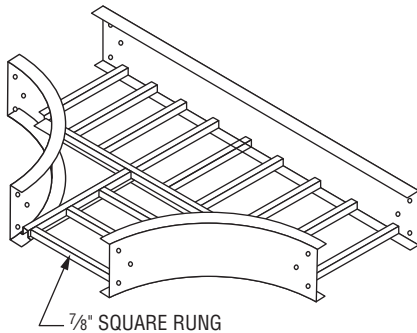

CSA Compliance for CSA Systems

| Radius - R            | Width - W   | "A" Dimension | "B" Dimension | "C" Dimension |
|-----------------------|-------------|---------------|---------------|---------------|
| <b>12"</b><br>(305mm) | 6" (152mm)  | 15" (381mm)   | 30" (762mm)   | 18" (457mm)   |
|                       | 9" (229mm)  | 16½" (419mm)  | 33" (838mm)   | 21" (533mm)   |
|                       | 12" (305mm) | 18" (457mm)   | 36" (914mm)   | 24" (610mm)   |
|                       | 18" (457mm) | 21" (533mm)   | 42" (1067mm)  | 30" (762mm)   |
|                       | 24" (610mm) | 24" (610mm)   | 48" (1219mm)  | 36" (914mm)   |
|                       | 30" (762mm) | 27" (686mm)   | 54" (1372mm)  | 42" (1067mm)  |
| <b>24"</b><br>(610mm) | 36" (914mm) | 30" (762mm)   | 60" (1524mm)  | 48" (1219mm)  |
|                       | 6" (152mm)  | 27" (686mm)   | 54" (1372mm)  | 30" (762mm)   |
|                       | 9" (229mm)  | 28½" (724mm)  | 57" (1448mm)  | 33" (838mm)   |
|                       | 12" (305mm) | 30" (762mm)   | 60" (1524mm)  | 36" (914mm)   |
|                       | 18" (457mm) | 33" (838mm)   | 66" (1676mm)  | 42" (1067mm)  |
|                       | 24" (610mm) | 36" (914mm)   | 72" (1829mm)  | 48" (1219mm)  |
| <b>36"</b><br>(914mm) | 30" (762mm) | 39" (991mm)   | 78" (1981mm)  | 54" (1372mm)  |
|                       | 36" (914mm) | 42" (1067mm)  | 84" (2134mm)  | 60" (1524mm)  |
|                       | 6" (152mm)  | 39" (991mm)   | 78" (1981mm)  | 42" (1067mm)  |
|                       | 9" (229mm)  | 40½" (1029mm) | 81" (2057mm)  | 45" (1143mm)  |
|                       | 12" (305mm) | 42" (1067mm)  | 84" (2134mm)  | 48" (1219mm)  |
|                       | 18" (457mm) | 45" (1143mm)  | 90" (2286mm)  | 54" (1372mm)  |
|                       | 24" (610mm) | 48" (1219mm)  | 96" (2438mm)  | 60" (1524mm)  |
|                       | 30" (762mm) | 51" (1295mm)  | 102" (2591mm) | 66" (1676mm)  |
|                       | 36" (914mm) | 54" (1372mm)  | 108" (2743mm) | 72" (1829mm)  |

Example: 24A-12FT-12

### Ordering Information:

See Page 133  
for Electrical  
Grounding Chart

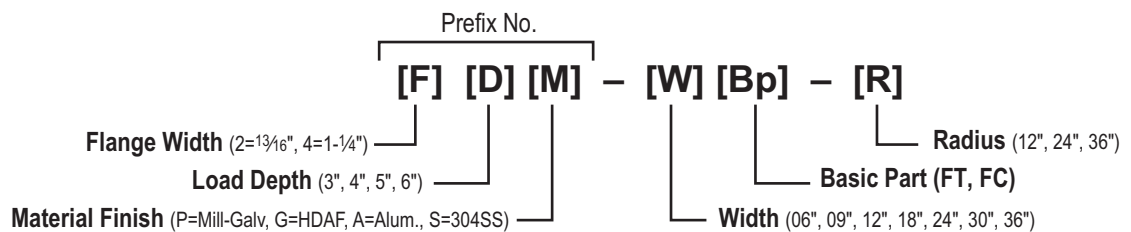

## Horizontal Cross [FC]

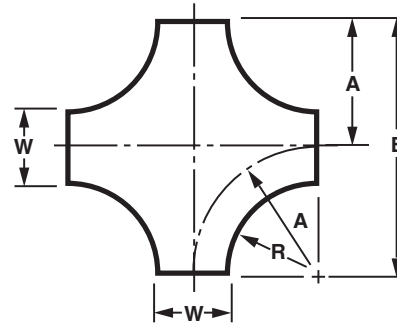
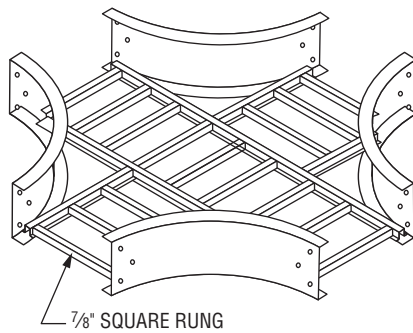

CSA Compliance for CSA Systems

| Radius<br>- R  | Width<br>- W | "A"<br>Dimension | "B"<br>Dimension |
|----------------|--------------|------------------|------------------|
| 12"<br>(305mm) | 6" (152mm)   | 15" (381mm)      | 30" (762mm)      |
|                | 9" (229mm)   | 16 1/2" (419mm)  | 33" (838mm)      |
|                | 12" (305mm)  | 18" (457mm)      | 36" (914mm)      |
|                | 18" (457mm)  | 21" (533mm)      | 42" (1067mm)     |
|                | 24" (610mm)  | 24" (610mm)      | 48" (1219mm)     |
|                | 30" (762mm)  | 27" (686mm)      | 54" (1372mm)     |
| 24"<br>(610mm) | 36" (914mm)  | 30" (762mm)      | 60" (1524mm)     |
|                | 6" (152mm)   | 27" (686mm)      | 54" (1372mm)     |
|                | 9" (229mm)   | 28 1/2" (724mm)  | 57" (1448mm)     |
|                | 12" (305mm)  | 30" (762mm)      | 60" (1524mm)     |
|                | 18" (457mm)  | 33" (838mm)      | 66" (1676mm)     |
|                | 24" (610mm)  | 36" (914mm)      | 72" (1829mm)     |
| 36"<br>(914mm) | 30" (762mm)  | 39" (991mm)      | 78" (1981mm)     |
|                | 36" (914mm)  | 42" (1067mm)     | 84" (2134mm)     |
|                | 6" (152mm)   | 39" (991mm)      | 78" (1981mm)     |
|                | 9" (229mm)   | 40 1/2" (1029mm) | 81" (2057mm)     |
|                | 12" (305mm)  | 42" (1067mm)     | 84" (2134mm)     |
|                | 18" (457mm)  | 45" (1143mm)     | 90" (2286mm)     |
| 36"<br>(914mm) | 24" (610mm)  | 48" (1219mm)     | 96" (2438mm)     |
|                | 30" (762mm)  | 51" (1295mm)     | 102" (2591mm)    |
|                | 36" (914mm)  | 54" (1372mm)     | 108" (2743mm)    |

Example: 24A-12FC-12

### Ordering Information:

See Page 133  
for Electrical  
Grounding Chart

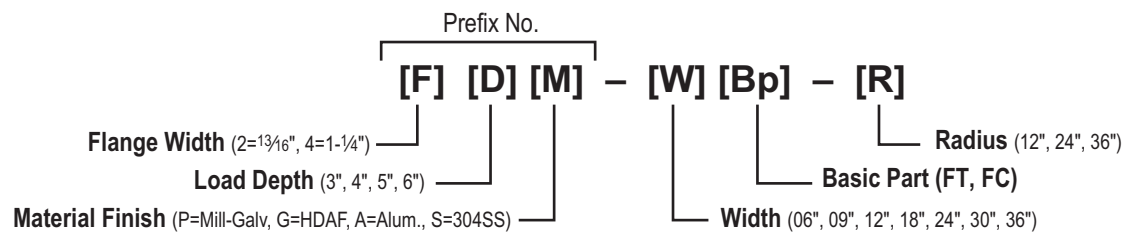

# HAT CABLE TRAY SYSTEM



## Horizontal Tapped Tee [TT]

CSA Compliance for CSA Systems

| R Radius       | W Width        | W1 Width       | "A" Dimension    | "C" Dimension    |                 |                 |
|----------------|----------------|----------------|------------------|------------------|-----------------|-----------------|
| 12"<br>(305mm) | 36"<br>(914mm) | 30" (762mm)    | 27" (686mm)      | 48"<br>(1219mm)  |                 |                 |
|                |                | 24" (610mm)    | 24" (610mm)      |                  |                 |                 |
|                |                | 18" (457mm)    | 21" (533mm)      |                  |                 |                 |
|                |                | 12" (305mm)    | 18" (457mm)      |                  |                 |                 |
|                |                | 9" (229mm)     | 16 1/2" (419mm)  |                  |                 |                 |
|                |                | 6" (152mm)     | 15" (381mm)      |                  |                 |                 |
|                | 30"<br>(762mm) | 24" (610mm)    | 24" (610mm)      | 42"<br>(1067mm)  |                 |                 |
|                |                | 18" (457mm)    | 21" (533mm)      |                  |                 |                 |
|                |                | 12" (305mm)    | 18" (457mm)      |                  |                 |                 |
|                |                | 9" (229mm)     | 16 1/2" (419mm)  |                  |                 |                 |
|                |                | 6" (152mm)     | 15" (381mm)      |                  |                 |                 |
|                |                | 24"<br>(610mm) | 18" (457mm)      |                  | 21" (533mm)     | 36"<br>(914mm)  |
|                | 12" (305mm)    |                | 18" (457mm)      |                  |                 |                 |
|                | 9" (229mm)     |                | 16 1/2" (419mm)  |                  |                 |                 |
|                | 6" (152mm)     |                | 15" (381mm)      |                  |                 |                 |
|                | 18"<br>(457mm) |                | 12" (305mm)      | 18" (457mm)      | 30"<br>(762mm)  |                 |
|                |                |                | 9" (229mm)       | 16 1/2" (419mm)  |                 |                 |
|                |                | 6" (152mm)     | 15" (381mm)      |                  |                 |                 |
|                | 12"<br>(305mm) | 9" (229mm)     | 16 1/2" (419mm)  | 24"<br>(610mm)   |                 |                 |
|                |                | 6" (152mm)     | 15" (381mm)      |                  |                 |                 |
|                | 9"<br>(229mm)  | 6" (152mm)     | 15" (381mm)      | 21"<br>(533mm)   |                 |                 |
|                | 36"<br>(914mm) | 36"<br>(914mm) | 30" (762mm)      | 51" (1295mm)     | 72"<br>(1829mm) |                 |
|                |                |                | 24" (610mm)      | 48" (1219mm)     |                 |                 |
|                |                |                | 18" (457mm)      | 45" (1143mm)     |                 |                 |
| 12" (305mm)    |                |                | 42" (1067mm)     |                  |                 |                 |
| 9" (229mm)     |                |                | 40 1/2" (1029mm) |                  |                 |                 |
| 6" (152mm)     |                |                | 39" (991mm)      |                  |                 |                 |
| 30"<br>(762mm) |                | 24" (610mm)    | 48" (1219mm)     | 66"<br>(1676mm)  |                 |                 |
|                |                | 18" (457mm)    | 45" (1143mm)     |                  |                 |                 |
|                |                | 12" (305mm)    | 42" (1067mm)     |                  |                 |                 |
|                |                | 9" (229mm)     | 40 1/2" (1029mm) |                  |                 |                 |
|                |                | 6" (152mm)     | 39" (991mm)      |                  |                 |                 |
|                |                | 24"<br>(610mm) | 18" (457mm)      |                  | 45" (1143mm)    | 60"<br>(1524mm) |
| 12" (305mm)    |                |                | 42" (1067mm)     |                  |                 |                 |
| 9" (229mm)     |                |                | 40 1/2" (1029mm) |                  |                 |                 |
| 6" (152mm)     |                |                | 39" (991mm)      |                  |                 |                 |
| 18"<br>(457mm) |                |                | 12" (305mm)      | 42" (1067mm)     | 54"<br>(1372mm) |                 |
|                |                |                | 9" (229mm)       | 40 1/2" (1029mm) |                 |                 |
|                |                | 6" (152mm)     | 39" (991mm)      |                  |                 |                 |
| 12"<br>(305mm) |                | 9" (229mm)     | 40 1/2" (1029mm) | 48"<br>(1219mm)  |                 |                 |
|                |                | 6" (152mm)     | 39" (991mm)      |                  |                 |                 |
| 9"<br>(229mm)  |                | 6" (152mm)     | 39" (991mm)      | 45"<br>(1143mm)  |                 |                 |

EXAMPLE: 24A-12TT-09-12

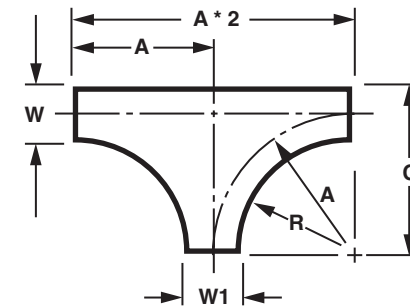
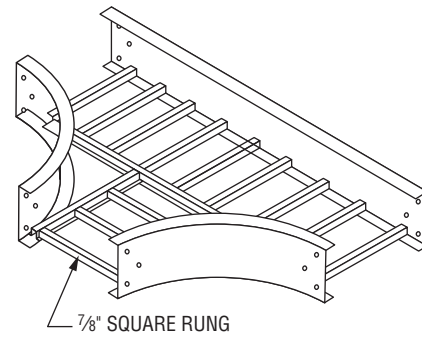

CSA Compliance for CSA Systems

| R Radius       | W Width        | W1 Width       | "A" Dimension   | "C" Dimension   |                 |                 |
|----------------|----------------|----------------|-----------------|-----------------|-----------------|-----------------|
| 24"<br>(610mm) | 36"<br>(914mm) | 30" (762mm)    | 39" (991mm)     | 60"<br>(1524mm) |                 |                 |
|                |                | 24" (610mm)    | 36" (914mm)     |                 |                 |                 |
|                |                | 18" (457mm)    | 33" (838mm)     |                 |                 |                 |
|                |                | 12" (305mm)    | 30" (762mm)     |                 |                 |                 |
|                |                | 9" (229mm)     | 28 1/2" (724mm) |                 |                 |                 |
|                |                | 6" (152mm)     | 27" (686mm)     |                 |                 |                 |
|                | 30"<br>(762mm) | 24" (610mm)    | 36" (914mm)     | 54"<br>(1372mm) |                 |                 |
|                |                | 18" (457mm)    | 33" (838mm)     |                 |                 |                 |
|                |                | 12" (305mm)    | 30" (762mm)     |                 |                 |                 |
|                |                | 9" (229mm)     | 28 1/2" (724mm) |                 |                 |                 |
|                |                | 6" (152mm)     | 27" (686mm)     |                 |                 |                 |
|                |                | 24"<br>(610mm) | 18" (457mm)     |                 | 33" (838mm)     | 48"<br>(1219mm) |
|                | 12" (305mm)    |                | 30" (762mm)     |                 |                 |                 |
|                | 9" (229mm)     |                | 28 1/2" (724mm) |                 |                 |                 |
|                | 6" (152mm)     |                | 27" (686mm)     |                 |                 |                 |
|                | 18"<br>(457mm) |                | 12" (305mm)     | 30" (762mm)     | 42"<br>(1067mm) |                 |
|                |                |                | 9" (229mm)      | 28 1/2" (724mm) |                 |                 |
|                |                | 6" (152mm)     | 27" (686mm)     |                 |                 |                 |
|                | 12"<br>(305mm) | 9" (229mm)     | 28 1/2" (724mm) | 36"<br>(914mm)  |                 |                 |
|                |                | 6" (152mm)     | 27" (686mm)     |                 |                 |                 |
|                | 9"<br>(229mm)  | 6" (152mm)     | 27" (686mm)     | 33"<br>(838mm)  |                 |                 |

### Ordering Information:

See Page 133  
for Electrical  
Grounding Chart

Prefix No. [F] [D] [M] - [W] [Bp] - [W1]- [R]

Flange Width (2=13/16", 4=1-1/4")

Load Depth (3", 4", 5", 6")

Material Finish (P=Mill-Galv, G=HDAF, A=Alum., S=304SS)

Width (06", 09", 12", 18", 24", 30", 36")

Basic Part (TT)

Radius (12", 24", 36")

Width (06", 09", 12", 18", 24", 30", 36")

## Horizontal Tapped Cross [TC] [Page 1 of 2]

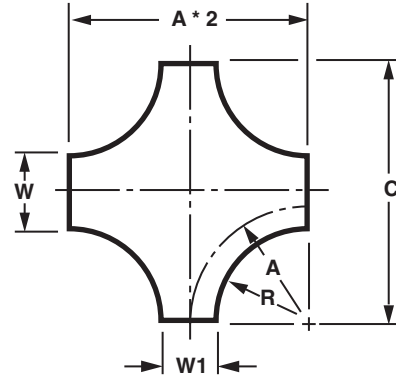
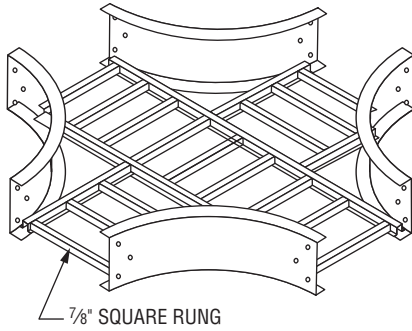

CSA Compliance for CSA Systems

| R<br>Radius    | W<br>Width      | W1<br>Width     | "A"<br>Dimension | "C"<br>Dimension |             |
|----------------|-----------------|-----------------|------------------|------------------|-------------|
| 12"<br>(305mm) | 36"<br>(914mm)  | 30" (762mm)     | 27" (686mm)      | 60"<br>(1524mm)  |             |
|                |                 | 24" (610mm)     | 24" (610mm)      |                  |             |
|                |                 | 18" (457mm)     | 21" (533mm)      |                  |             |
|                |                 | 12" (305mm)     | 18" (457mm)      |                  |             |
|                |                 | 9" (229mm)      | 16 1/2" (419mm)  |                  |             |
|                |                 | 6" (152mm)      | 15" (381mm)      |                  |             |
|                | 30"<br>(762mm)  | 24" (610mm)     | 24" (610mm)      | 54"<br>(1372mm)  |             |
|                |                 | 18" (457mm)     | 21" (533mm)      |                  |             |
|                |                 | 12" (305mm)     | 18" (457mm)      |                  |             |
|                |                 | 9" (229mm)      | 16 1/2" (419mm)  |                  |             |
|                |                 | 6" (152mm)      | 15" (381mm)      |                  |             |
|                |                 | 24"<br>(610mm)  | 18" (457mm)      |                  | 21" (533mm) |
| 12" (305mm)    | 18" (457mm)     |                 |                  |                  |             |
| 9" (229mm)     | 16 1/2" (419mm) |                 |                  |                  |             |
| 6" (152mm)     | 15" (381mm)     |                 |                  |                  |             |
| 18"<br>(457mm) | 12" (305mm)     |                 | 18" (457mm)      | 42"<br>(1067mm)  |             |
|                | 9" (229mm)      |                 | 16 1/2" (419mm)  |                  |             |
|                | 6" (152mm)      | 15" (381mm)     |                  |                  |             |
| 12"<br>(305mm) | 9" (229mm)      | 16 1/2" (419mm) | 36"<br>(914mm)   |                  |             |
|                | 6" (152mm)      | 15" (381mm)     |                  |                  |             |
| 9"<br>(229mm)  | 6" (152mm)      | 15" (381mm)     | 33"<br>(838mm)   |                  |             |

EXAMPLE: 24A-36TC-18-12

### Ordering Information:

See Page 133  
for Electrical  
Grounding Chart

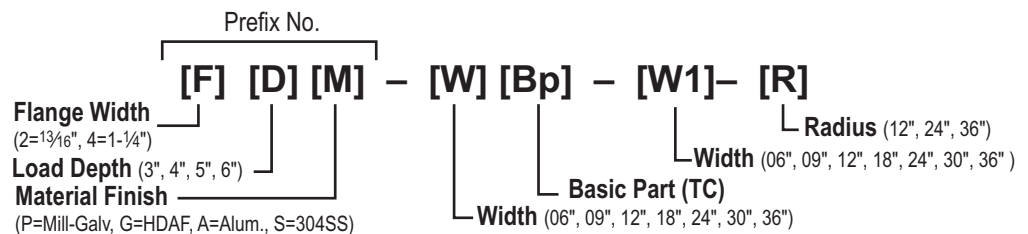

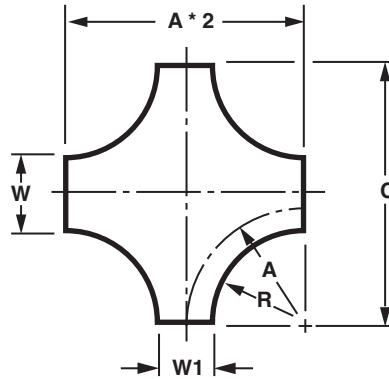

CSA Compliance for CSA Systems

| R Radius       | W Width         | W1 Width        | "A" Dimension   | "C" Dimension   |
|----------------|-----------------|-----------------|-----------------|-----------------|
| 24"<br>(610mm) | 36"<br>(914mm)  | 30" (762mm)     | 39" (991mm)     | 84"<br>(2134mm) |
|                |                 | 24" (610mm)     | 36" (914mm)     |                 |
|                |                 | 18" (457mm)     | 33" (838mm)     |                 |
|                |                 | 12" (305mm)     | 30" (762mm)     |                 |
|                |                 | 9" (229mm)      | 28 1/2" (724mm) |                 |
|                |                 | 6" (152mm)      | 27" (686mm)     |                 |
|                | 30"<br>(762mm)  | 24" (610mm)     | 36" (914mm)     | 78"<br>(1981mm) |
|                |                 | 18" (457mm)     | 33" (838mm)     |                 |
|                |                 | 12" (305mm)     | 30" (762mm)     |                 |
|                |                 | 9" (229mm)      | 28 1/2" (724mm) |                 |
|                |                 | 6" (152mm)      | 27" (686mm)     |                 |
|                |                 | 24"<br>(610mm)  | 18" (457mm)     |                 |
| 12" (305mm)    | 30" (762mm)     |                 |                 |                 |
| 9" (229mm)     | 28 1/2" (724mm) |                 |                 |                 |
| 6" (152mm)     | 27" (686mm)     |                 |                 |                 |
| 18"<br>(457mm) | 12" (305mm)     | 30" (762mm)     | 66"<br>(1676mm) |                 |
|                | 9" (229mm)      | 28 1/2" (724mm) |                 |                 |
|                | 6" (152mm)      | 27" (686mm)     |                 |                 |
| 12"<br>(305mm) | 9" (229mm)      | 28 1/2" (724mm) | 60"<br>(1524mm) |                 |
|                | 6" (152mm)      | 27" (686mm)     |                 |                 |
| 9"<br>(229mm)  | 6" (152mm)      | 27" (686mm)     | 57"<br>(1448mm) |                 |

CSA Compliance for CSA Systems

| R Radius       | W Width        | W1 Width         | "A" Dimension    | "C" Dimension    |
|----------------|----------------|------------------|------------------|------------------|
| 36"<br>(914mm) | 36"<br>(914mm) | 30" (762mm)      | 51" (1295mm)     | 108"<br>(2743mm) |
|                |                | 24" (610mm)      | 48" (1219mm)     |                  |
|                |                | 18" (457mm)      | 45" (1143mm)     |                  |
|                |                | 12" (305mm)      | 42" (1067mm)     |                  |
|                |                | 9" (229mm)       | 40 1/2" (1029mm) |                  |
|                |                | 6" (152mm)       | 39" (991mm)      |                  |
|                | 30"<br>(762mm) | 24" (610mm)      | 48" (1219mm)     | 102"<br>(2591mm) |
|                |                | 18" (457mm)      | 45" (1143mm)     |                  |
|                |                | 12" (305mm)      | 42" (1067mm)     |                  |
|                |                | 9" (229mm)       | 40 1/2" (1029mm) |                  |
|                | 24"<br>(610mm) | 18" (457mm)      | 45" (1143mm)     | 96"<br>(2438mm)  |
|                |                | 12" (305mm)      | 42" (1067mm)     |                  |
| 9" (229mm)     |                | 40 1/2" (1029mm) |                  |                  |
| 6" (152mm)     |                | 39" (991mm)      |                  |                  |
| 18"<br>(457mm) | 12" (305mm)    | 42" (1067mm)     | 90"<br>(2286mm)  |                  |
|                | 9" (229mm)     | 40 1/2" (1029mm) |                  |                  |
|                | 6" (152mm)     | 39" (991mm)      |                  |                  |
| 12"<br>(305mm) | 9" (229mm)     | 40 1/2" (1029mm) | 84"<br>(2134mm)  |                  |
|                | 6" (152mm)     | 39" (991mm)      |                  |                  |
| 9"<br>(229mm)  | 6" (152mm)     | 39" (991mm)      | 81"<br>(2057mm)  |                  |

Ordering Information:

See Page 133 for Electrical Grounding Chart

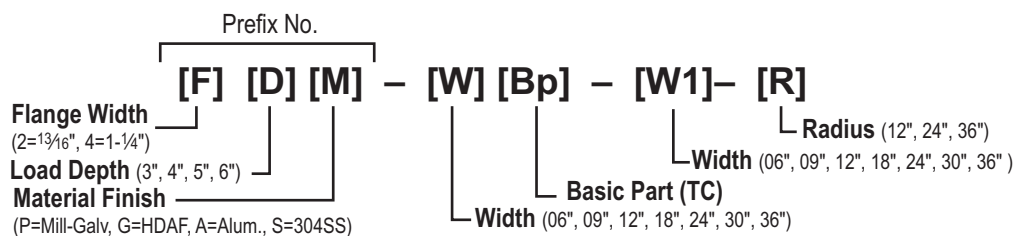

## Straight Reducer [ST]

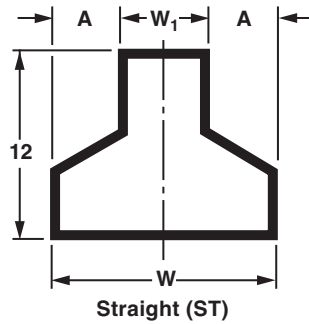
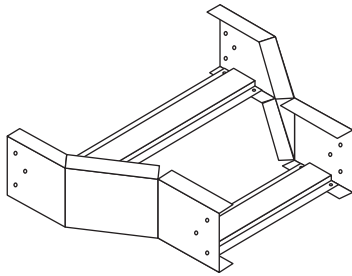

CSA Compliance for CSA Systems

| Width - W             | Width - W1  | "A" Dimension   |
|-----------------------|-------------|-----------------|
| <b>36"</b><br>(914mm) | 30" (762mm) | 3" (76mm)       |
|                       | 24" (610mm) | 6" (152mm)      |
|                       | 18" (457mm) | 9" (229mm)      |
|                       | 12" (305mm) | 12" (305mm)     |
|                       | 9" (229mm)  | 13 1/2" (343mm) |
|                       | 6" (152mm)  | 15" (381mm)     |
| <b>30"</b><br>(762mm) | 24" (610mm) | 3" (76mm)       |
|                       | 18" (457mm) | 6" (152mm)      |
|                       | 12" (305mm) | 9" (229mm)      |
|                       | 9" (229mm)  | 10 1/2" (267mm) |
|                       | 6" (152mm)  | 12" (304mm)     |
| <b>24"</b><br>(610mm) | 18" (457mm) | 3" (76mm)       |
|                       | 12" (305mm) | 6" (152mm)      |
|                       | 9" (229mm)  | 7 1/2" (191mm)  |
|                       | 6" (152mm)  | 9" (229mm)      |
| <b>18"</b><br>(457mm) | 12" (305mm) | 3" (76mm)       |
|                       | 9" (229mm)  | 4 1/2" (114mm)  |
|                       | 6" (152mm)  | 6" (152mm)      |
| <b>12"</b><br>(305mm) | 9" (229mm)  | 1 1/2" (38mm)   |
|                       | 6" (152mm)  | 3" (76mm)       |
| <b>9"</b><br>(229mm)  | 6" (152mm)  | 1 1/2" (38mm)   |

EXAMPLE: 24A-12ST-06

## Left Hand [LH] & Right Hand [RH] Reducer

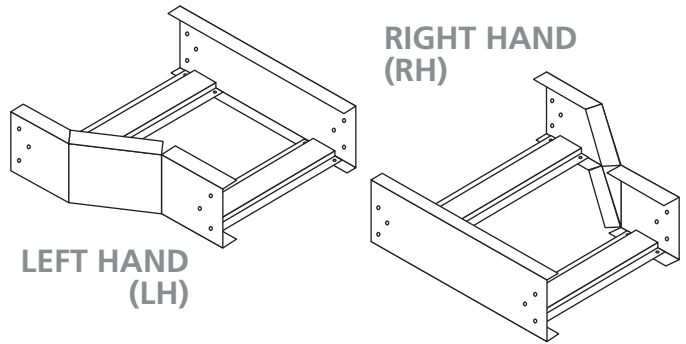

LEFT HAND (LH)

RIGHT HAND (RH)

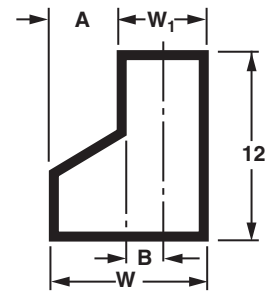
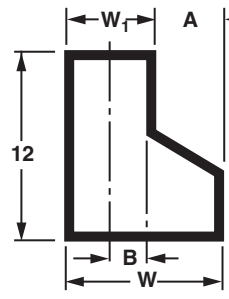

CSA Compliance for CSA Systems

| Width - W             | "W1" Dim.   | "A" Dim.    | "B" Dim.       |
|-----------------------|-------------|-------------|----------------|
| <b>36"</b><br>(914mm) | 30" (914mm) | 6" (152mm)  | 15" (381mm)    |
|                       | 24" (610mm) | 12" (305mm) | 12" (305mm)    |
|                       | 18" (457mm) | 18" (457mm) | 9" (229mm)     |
|                       | 12" (305mm) | 24" (610mm) | 6" (152mm)     |
|                       | 9" (229mm)  | 27" (686mm) | 4 1/2" (114mm) |
|                       | 6" (152mm)  | 30" (762mm) | 3" (76mm)      |
|                       | 24" (610mm) | 6" (152mm)  | 12" (305mm)    |
| <b>30"</b><br>(762mm) | 18" (457mm) | 12" (305mm) | 9" (229mm)     |
|                       | 12" (305mm) | 18" (457mm) | 6" (152mm)     |
|                       | 9" (229mm)  | 21" (533mm) | 4 1/2" (114mm) |
|                       | 6" (152mm)  | 24" (610mm) | 3" (76mm)      |
|                       | 18" (457mm) | 6" (152mm)  | 9" (229mm)     |
| <b>24"</b><br>(610mm) | 12" (305mm) | 12" (305mm) | 6" (152mm)     |
|                       | 9" (229mm)  | 15" (381mm) | 4 1/2" (114mm) |
|                       | 6" (152mm)  | 18" (457mm) | 3" (76mm)      |
|                       | 12" (305mm) | 6" (152mm)  | 6" (152mm)     |
| <b>18"</b><br>(457mm) | 9" (229mm)  | 9" (229mm)  | 4 1/2" (114mm) |
|                       | 6" (152mm)  | 12" (305mm) | 3" (76mm)      |
|                       | 9" (229mm)  | 3" (76mm)   | 4 1/2" (114mm) |
| <b>12"</b><br>(305mm) | 6" (152mm)  | 6" (152mm)  | 3" (76mm)      |
|                       | 9" (229mm)  | 3" (76mm)   | 4 1/2" (114mm) |
| <b>9"</b><br>(229mm)  | 6" (152mm)  | 3" (76mm)   | 3" (76mm)      |

EXAMPLE: 238-12LH-06

### Ordering Information:

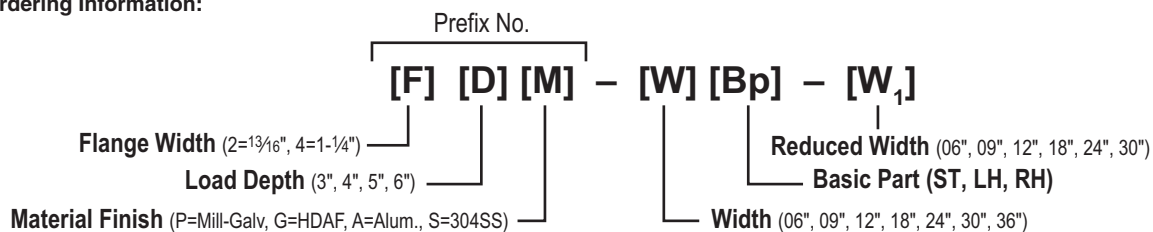

See Page 133  
for Electrical  
Grounding Chart

# HAT CABLE TRAY SYSTEM

## Adjustable Elbow [AF]

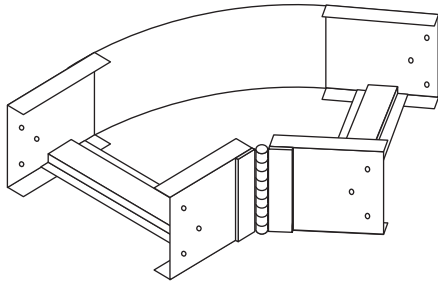

| Width - W |         | "A" Dimension |         |
|-----------|---------|---------------|---------|
| 6"        | (152mm) | 8"            | (203mm) |
| 9"        | (229mm) | 11"           | (279mm) |
| 12"       | (305mm) | 14"           | (356mm) |
| 18"       | (457mm) | 20"           | (508mm) |
| 24"       | (610mm) | 26"           | (660mm) |
| 30"       | (762mm) | 32"           | (813mm) |
| 36"       | (914mm) | 38"           | (965mm) |

Both rails at hinge break to be bonded if fitting is used as equipment grounding conductor.  
**EXAMPLE:** 24A-12AF

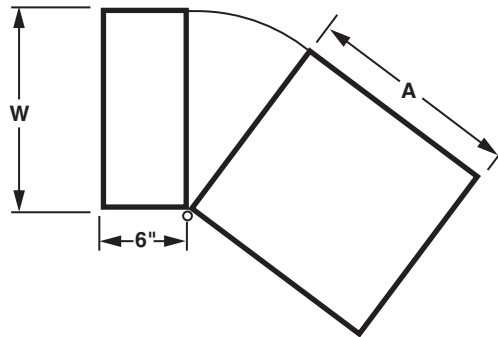

## 45° "Y" Branch Left [LY] & Right [RY]

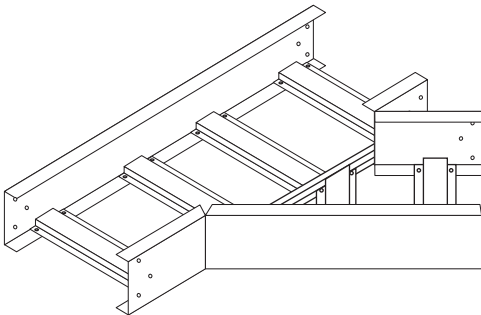

### CSA Compliance for CSA Systems

| Width - W   | "A" Dim.         | "B" Dim.         | "C" Dim.         | "D" Dim.        |
|-------------|------------------|------------------|------------------|-----------------|
| 6" (152mm)  | 22 1/2" (571mm)  | 16 1/4" (413mm)  | 9 1/4" (239mm)   | 11 1/8" (283mm) |
| 9" (229mm)  | 26 3/4" (679mm)  | 21 3/8" (543mm)  | 9 13/16" (330mm) | 13 3/4" (349mm) |
| 12" (305mm) | 31" (787mm)      | 26 1/2" (673mm)  | 10 1/2" (375mm)  | 16 1/4" (412mm) |
| 18" (457mm) | 39 1/2" (1003mm) | 36 3/4" (933mm)  | 11 3/4" (460mm)  | 21 3/8" (543mm) |
| 24" (610mm) | 48" (1219mm)     | 47" (1193mm)     | 13" (546mm)      | 26 1/2" (673mm) |
| 30" (762mm) | 56 3/8" (1432mm) | 57 1/4" (1454mm) | 14 1/8" (629mm)  | 31 5/8" (803mm) |
| 36" (914mm) | 65" (1651mm)     | 67 1/2" (1714mm) | 15 1/2" (718mm)  | 36 3/4" (933mm) |

**EXAMPLE:** 24A-12RY

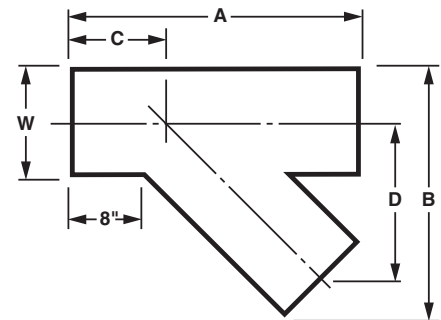

RIGHT SIDE [RY]  
SHOWN

### Ordering Information:

See Page 133  
for Electrical  
Grounding Chart

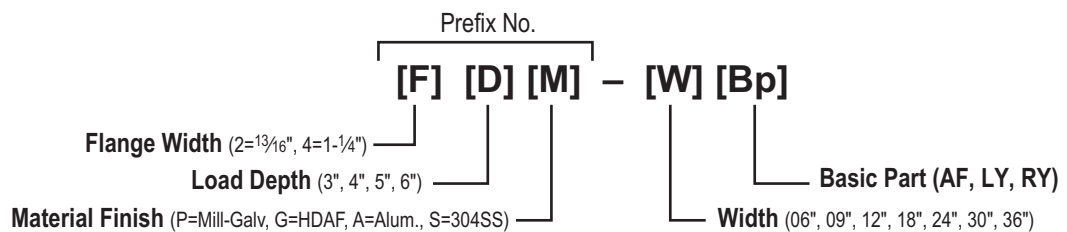

## 90° Vertical Elbow Outside [90] & Inside [9I]

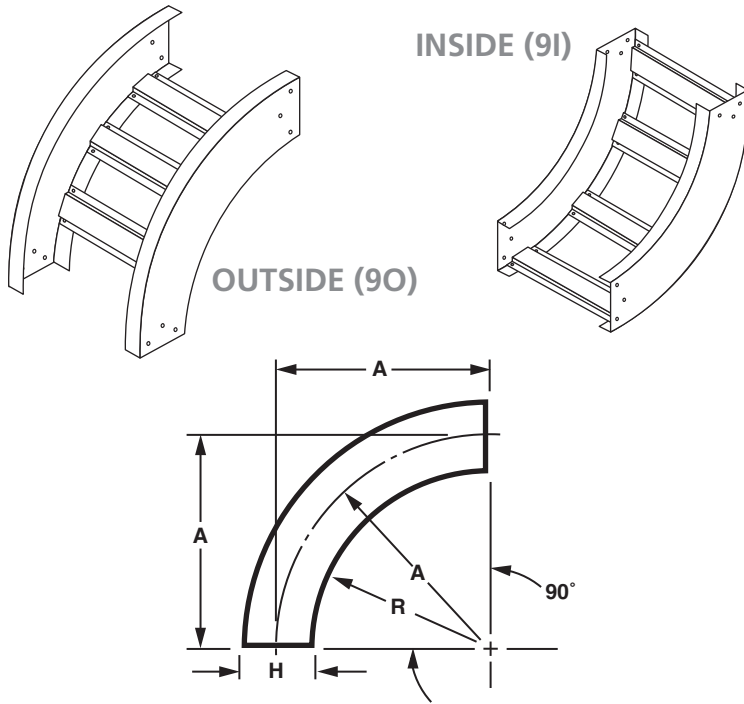

| CSA Compliance for CSA Systems |                |                 |  |
|--------------------------------|----------------|-----------------|--|
| Radius - R                     | "H" Dim.       | "A" Dim.        |  |
| <b>12"</b><br>(305mm)          | 3 1/2" (89mm)  | 13 3/4" (349mm) |  |
|                                | 4 1/4" (108mm) | 14 1/8" (359mm) |  |
|                                | 5 1/4" (133mm) | 14 5/8" (372mm) |  |
|                                | 6 1/4" (159mm) | 15 1/8" (384mm) |  |
| <b>24"</b><br>(610mm)          | 3 1/2" (89mm)  | 25 3/4" (649mm) |  |
|                                | 4 1/4" (108mm) | 26 1/8" (664mm) |  |
|                                | 5 1/4" (133mm) | 26 5/8" (676mm) |  |
|                                | 6 1/4" (159mm) | 27 1/8" (689mm) |  |
| <b>36"</b><br>(914mm)          | 7 1/4" (184mm) | 37 3/4" (702mm) |  |
|                                | 4 1/4" (108mm) | 38 1/8" (969mm) |  |
|                                | 5 1/4" (133mm) | 38 5/8" (981mm) |  |
|                                | 6 1/4" (159mm) | 39 1/8" (994mm) |  |

EXAMPLE: 24A-1290-12

## 60° Vertical Elbow Outside [60] & Inside [6I]

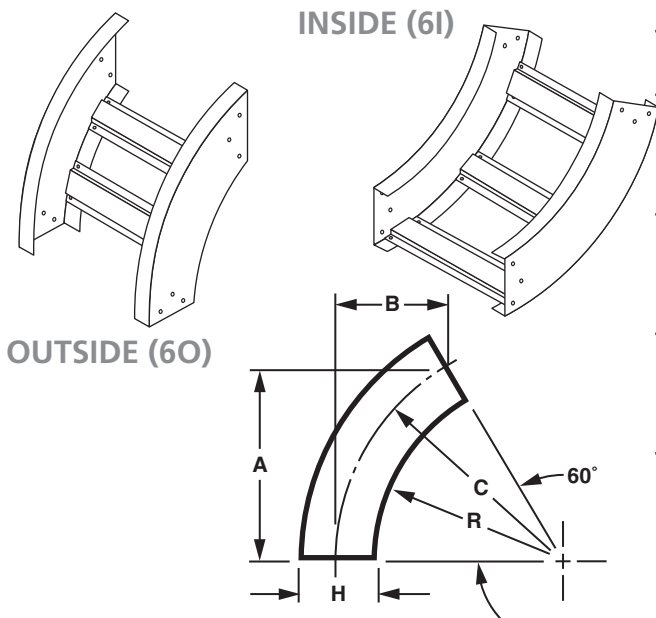

| CSA Compliance for CSA Systems |                |                 |                 |                 |
|--------------------------------|----------------|-----------------|-----------------|-----------------|
| Radius - R                     | "H" Dim.       | "A" Dim.        | "B" Dim.        | "C" Dim.        |
| <b>12"</b><br>(305mm)          | 3 1/2" (89mm)  | 11 7/8" (302mm) | 6 7/8" (175mm)  | 13 3/4" (349mm) |
|                                | 4 1/4" (108mm) | 12 1/4" (311mm) | 7 1/8" (181mm)  | 14 1/8" (359mm) |
|                                | 5 1/4" (133mm) | 12 5/8" (321mm) | 7 3/8" (187mm)  | 14 5/8" (372mm) |
|                                | 6 1/4" (159mm) | 13 1/8" (334mm) | 7 5/8" (194mm)  | 15 1/8" (384mm) |
| <b>24"</b><br>(610mm)          | 3 1/2" (89mm)  | 22 1/4" (565mm) | 12 7/8" (327mm) | 25 3/4" (649mm) |
|                                | 4 1/4" (108mm) | 22 5/8" (575mm) | 13 1/8" (334mm) | 26 1/8" (664mm) |
|                                | 5 1/4" (133mm) | 23 1/8" (588mm) | 13 3/8" (340mm) | 26 5/8" (676mm) |
|                                | 6 1/4" (159mm) | 23 1/2" (597mm) | 13" (330mm)     | 27 1/8" (689mm) |
| <b>36"</b><br>(914mm)          | 3 1/2" (89mm)  | 32 3/4" (832mm) | 18 7/8" (480mm) | 37 3/4" (959mm) |
|                                | 4 1/4" (108mm) | 33" (838mm)     | 19 1/8" (486mm) | 38 1/8" (969mm) |
|                                | 5 1/4" (133mm) | 33 1/2" (851mm) | 19 3/8" (492mm) | 38 5/8" (981mm) |
|                                | 6 1/4" (159mm) | 33 7/8" (861mm) | 19 5/8" (499mm) | 39 1/8" (994mm) |

EXAMPLE: 24A-1260-12

### Ordering Information:

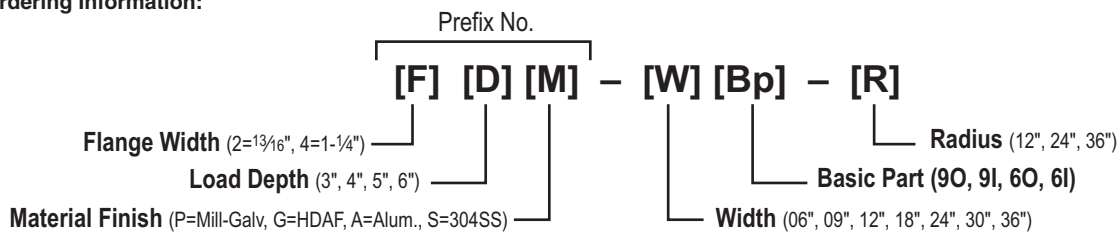

See Page 133  
for Electrical  
Grounding Chart

# HAT CABLE TRAY SYSTEM

## 45° Vertical Elbow Outside [40] & Inside [4I]

### OUTSIDE (40)

### INSIDE (4I)

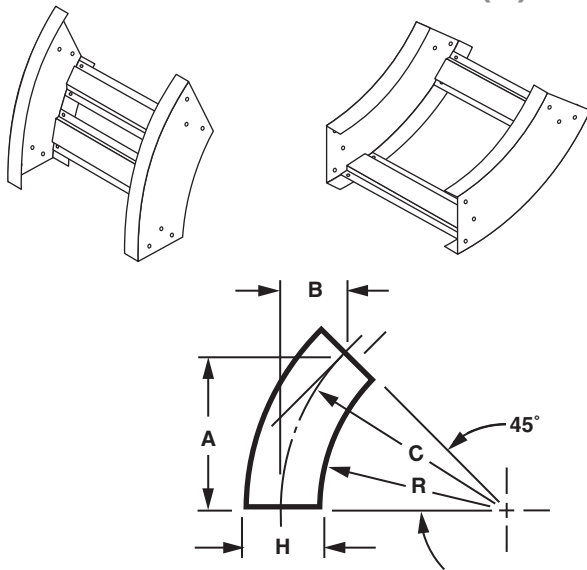

### CSA Compliance for CSA Systems

| Radius - R            | "H" Dim.       | "A" Dim.        | "B" Dim.        | "C" Dim.        |
|-----------------------|----------------|-----------------|-----------------|-----------------|
| <b>12"</b><br>(305mm) | 3 1/2" (89mm)  | 9 3/4" (248mm)  | 4" (102mm)      | 13 3/4" (349mm) |
|                       | 4 1/4" (108mm) | 10" (254mm)     | 4 1/8" (105mm)  | 14 1/8" (359mm) |
|                       | 5 1/4" (133mm) | 10 3/8" (264mm) | 4 1/4" (108mm)  | 14 5/8" (372mm) |
|                       | 6 1/4" (159mm) | 10 3/4" (273mm) | 4 1/2" (114mm)  | 15 1/8" (384mm) |
| <b>24"</b><br>(610mm) | 4 1/4" (108mm) | 18 1/2" (470mm) | 7 5/8" (194mm)  | 26 1/8" (664mm) |
|                       | 5 1/4" (133mm) | 18 7/8" (480mm) | 7 7/8" (200mm)  | 26 5/8" (676mm) |
|                       | 6 1/4" (159mm) | 19 1/4" (489mm) | 8" (203mm)      | 27 1/8" (689mm) |
|                       | 3 1/2" (89mm)  | 18 1/4" (464mm) | 7 1/2" (191mm)  | 25 3/4" (654mm) |
| <b>36"</b><br>(914mm) | 3 1/2" (89mm)  | 9 3/4" (248mm)  | 4" (102mm)      | 13 3/4" (349mm) |
|                       | 4 1/4" (108mm) | 27" (686mm)     | 11 1/8" (283mm) | 38 1/8" (969mm) |
|                       | 5 1/4" (133mm) | 27 3/8" (695mm) | 11 3/8" (289mm) | 38 5/8" (981mm) |
|                       | 6 1/4" (159mm) | 27 5/8" (702mm) | 11 1/2" (292mm) | 39 1/8" (994mm) |

EXAMPLE: 24A-1240-12

## 30° Vertical Elbow Outside [30] & Inside [3I]

### OUTSIDE (30)

### INSIDE (3I)

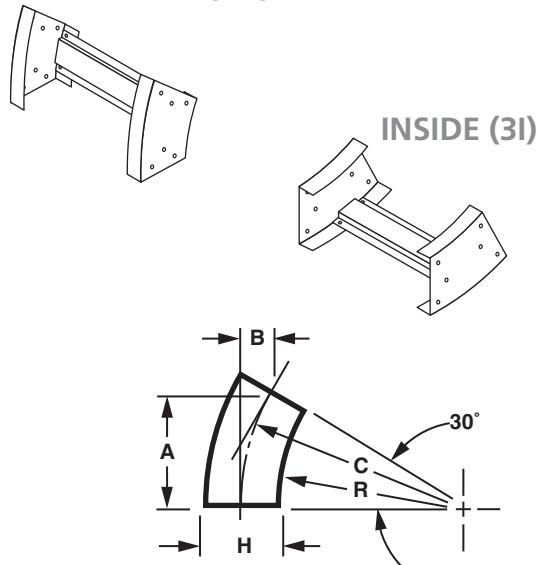

### CSA Compliance for CSA Systems

| Radius - R            | "H" Dim.       | "A" Dim.        | "B" Dim.       | "C" Dim.        |
|-----------------------|----------------|-----------------|----------------|-----------------|
| <b>12"</b><br>(305mm) | 3 1/2" (89mm)  | 6 7/8" (175mm)  | 1 7/8" (48mm)  | 13 3/4" (349mm) |
|                       | 4 1/4" (108mm) | 7 1/8" (181mm)  | 1 7/8" (48mm)  | 14 1/8" (359mm) |
|                       | 5 1/4" (133mm) | 7 3/8" (187mm)  | 2" (51mm)      | 14 5/8" (372mm) |
|                       | 6 1/4" (159mm) | 7 5/8" (194mm)  | 2" (51mm)      | 15 1/8" (384mm) |
| <b>24"</b><br>(610mm) | 3 1/2" (89mm)  | 12 7/8" (327mm) | 3 1/2" (89mm)  | 24 3/4" (654mm) |
|                       | 4 1/4" (108mm) | 13 1/8" (334mm) | 3 1/2" (89mm)  | 26 1/8" (664mm) |
|                       | 5 1/4" (133mm) | 13 3/8" (340mm) | 3 5/8" (92mm)  | 26 5/8" (676mm) |
|                       | 6 1/4" (159mm) | 13 5/8" (346mm) | 3 5/8" (92mm)  | 27 1/8" (689mm) |
| <b>36"</b><br>(914mm) | 3 1/2" (89mm)  | 18 7/8" (480mm) | 5 1/8" (130mm) | 37 3/4" (959mm) |
|                       | 4 1/4" (108mm) | 19 1/8" (486mm) | 5 1/8" (130mm) | 38 1/8" (969mm) |
|                       | 5 1/4" (133mm) | 19 3/8" (492mm) | 5 1/4" (133mm) | 38 5/8" (981mm) |
|                       | 6 1/4" (159mm) | 19 5/8" (499mm) | 5 1/4" (133mm) | 39 1/8" (994mm) |

EXAMPLE: 24A-1230-12

### Ordering Information:

See Page 133  
for Electrical  
Grounding Chart

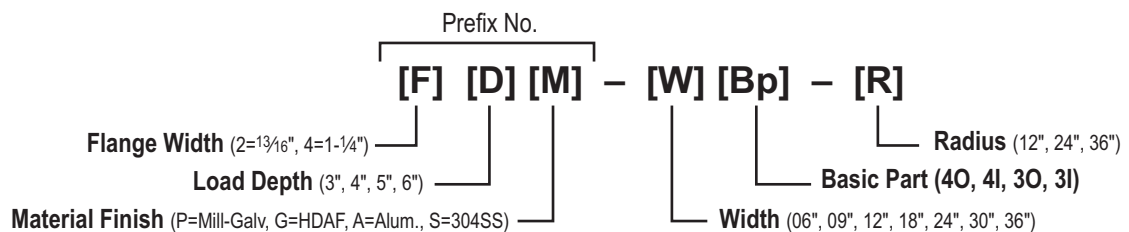

## 90° Vertical Cable Support Elbow (SR)

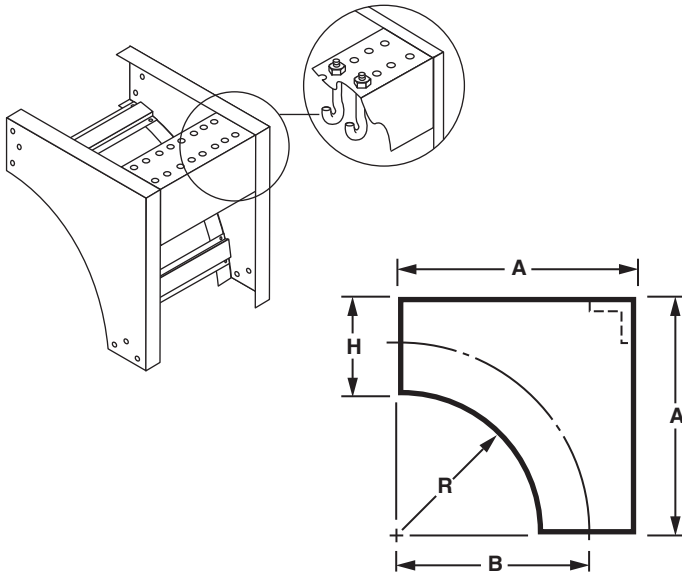

CSA Compliance for CSA Systems

| Radius - R            | "H" Dim.       | "A" Dim.         | "B" Dim.        |
|-----------------------|----------------|------------------|-----------------|
| <b>12"</b><br>(305mm) | 3 1/2" (89mm)  | 15 1/2" (394mm)  | 13 3/4" (349mm) |
|                       | 4 1/4" (108mm) | 16 1/4" (413mm)  | 14 1/8" (359mm) |
|                       | 5 1/4" (133mm) | 17 1/4" (438mm)  | 14 5/8" (371mm) |
|                       | 6 1/4" (159mm) | 18 1/4" (464mm)  | 15 1/8" (384mm) |
| <b>24"</b><br>(610mm) | 3 1/2" (89mm)  | 27 1/2" (699mm)  | 25 3/4" (654mm) |
|                       | 4 1/4" (108mm) | 28 1/4" (718mm)  | 26 1/8" (664mm) |
|                       | 5 1/4" (133mm) | 29 1/4" (743mm)  | 26 5/8" (676mm) |
|                       | 6 1/4" (159mm) | 30 1/4" (768mm)  | 27 1/8" (689mm) |
| <b>36"</b><br>(914mm) | 3 1/2" (89mm)  | 39 1/2" (1003mm) | 37 3/4" (959mm) |
|                       | 4 1/4" (108mm) | 40 1/4" (1022mm) | 38 1/8" (968mm) |
|                       | 5 1/4" (133mm) | 41 1/4" (1048mm) | 38 5/8" (981mm) |
|                       | 6 1/4" (159mm) | 42 1/4" (1073mm) | 39 1/8" (994mm) |

EXAMPLE: 24A-12SR-12

## Vertical Tee Down [VT] & Up [OT]

### VERTICAL TEE - DOWN (VT)

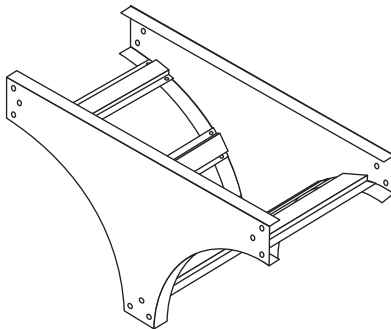

CSA Compliance for CSA Systems

| Radius - R            | "H" Dim.       | "A" Dim.         | "B" Dim.         | "C" Dim.        |
|-----------------------|----------------|------------------|------------------|-----------------|
| <b>12"</b><br>(305mm) | 3 1/2" (89mm)  | 27 1/2" (718mm)  | 15 1/2" (394mm)  | 13 3/4" (349mm) |
|                       | 4 1/4" (108mm) | 28 1/4" (743mm)  | 16 1/4" (413mm)  | 14 1/8" (359mm) |
|                       | 5 1/4" (133mm) | 29 1/4" (768mm)  | 17 1/4" (438mm)  | 14 5/8" (371mm) |
|                       | 6 1/4" (159mm) | 30 1/4" (794mm)  | 18 1/4" (464mm)  | 15 1/8" (384mm) |
| <b>24"</b><br>(610mm) | 3 1/2" (89mm)  | 51 1/2" (1327mm) | 27 1/2" (699mm)  | 25 3/4" (654mm) |
|                       | 4 1/4" (108mm) | 52 1/4" (1353mm) | 28 1/4" (718mm)  | 26 1/8" (664mm) |
|                       | 5 1/4" (133mm) | 53 1/4" (1378mm) | 29 1/4" (743mm)  | 26 5/8" (676mm) |
|                       | 6 1/4" (159mm) | 54 1/4" (1403mm) | 30 1/4" (768mm)  | 27 1/8" (689mm) |
| <b>36"</b><br>(914mm) | 3 1/2" (89mm)  | 75 1/2" (1937mm) | 39 1/2" (1003mm) | 37 3/4" (959mm) |
|                       | 4 1/4" (108mm) | 76 1/4" (1962mm) | 40 1/4" (1022mm) | 38 1/8" (968mm) |
|                       | 5 1/4" (133mm) | 77 1/4" (1988mm) | 41 1/4" (1048mm) | 38 5/8" (981mm) |
|                       | 6 1/4" (159mm) | 78 1/4" (2013mm) | 42 1/4" (1073mm) | 39 1/8" (994mm) |

EXAMPLE: 24A-12VT-12

### VERTICAL TEE - UP (OT)

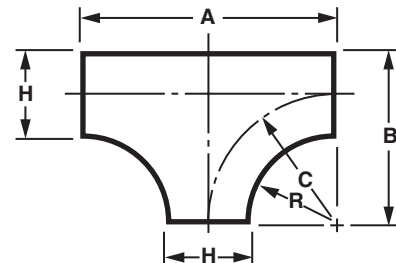
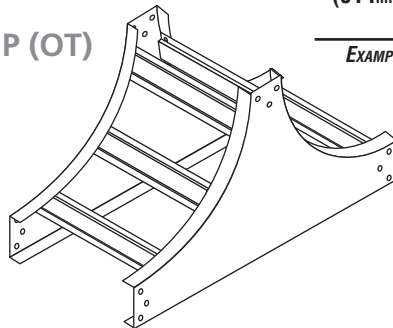

### Ordering Information:

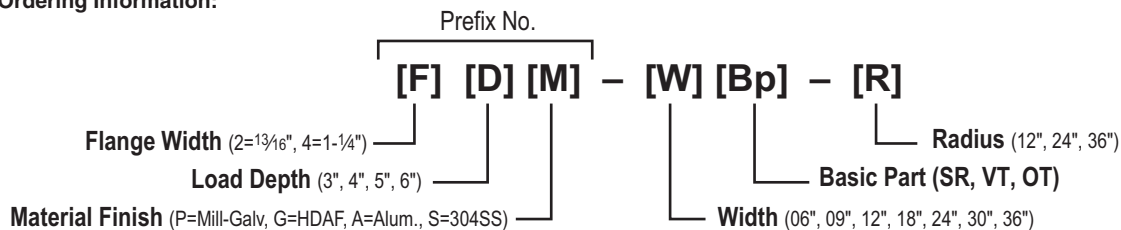

See Page 133 for Electrical Grounding Chart

# HAT CABLE TRAY SYSTEM

## CONNECTOR PLATES

### Tray Connectors

| Catalog Number |                |                |
|----------------|----------------|----------------|
| Load Depth     | Finish         | Basic No.      |
| 3"             | 2 (Mill Galv.) | -02RC          |
| 4"             | 3 (HDGAF)      | -02CE          |
| 5"             | 4 (Alum.)      | -02CV          |
| 6"             | U (304SS)      | -02CH<br>-02CA |

**EXAMPLE:** 34 -02RC for 3" load depth, aluminum, universal curvilinear connector.

**NOTE:** Hole patterns match corresponding tray.  
Three-hole pattern illustrated.

### Universal Curvilinear Connectors [RC]

**Note:** Sold in pairs

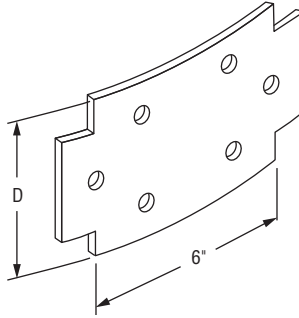

11 Gage Steel, 0.125" Aluminum  
3/8"-16 spline bolts & flange nuts furnished.

### Expansion Connectors [CE]

**Note:** Sold in pairs

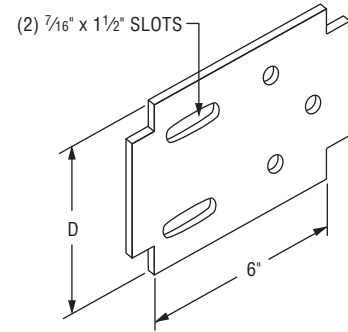

11 Gage Steel, 0.125" Aluminum  
3/8"-16 cap screws & Nylok nuts furnished and  
3/8"-16 spline bolts & flange nuts furnished.

**Note:** Bounding jumpers are required and are sold separately.

### Horizontal Adjustable Connectors [CH]

**Note:** Sold in pairs – inner & outer

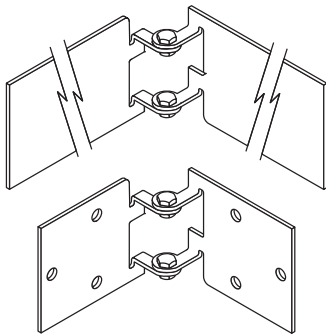

11 Gage Steel, 0.125" Aluminum  
3/8"-16 spline bolts & flange nuts furnished.  
**Note:** Bounding jumpers are required and are sold separately.

### Vertical Adjustable Connectors [CV]

**Note:** Sold in pairs)

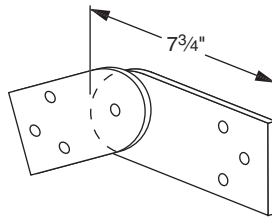

11 Gage Steel, 0.125" Aluminum  
3/8"-16 spline bolts & flange nuts furnished.  
**Note:** Bounding jumpers are required and are sold separately.

### 90° Angle Connectors [CA]

**Note:** Sold in pairs

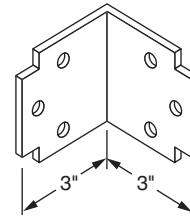

11 Gage Steel, 0.125" Aluminum  
3/8"-16 spline bolts and flange nuts furnished.

### Reducing Connector [CO]

**Note:** Not sold in pairs

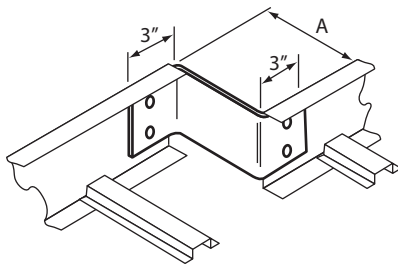

12 Gage Steel, 0.125" Aluminum  
For offset reductions – use 1 of above with standard connector plate.  
For straight reductions– use 2 (of 1/2 reduction dim.).  
3/8"-16 spline bolts and flange nuts furnished.

### Catalog Number

| Load Depth | Finish         | Basic No. | "A" Dimension   |
|------------|----------------|-----------|-----------------|
| 3"         | 2 (Mill Galv.) | -30CO     | 30" (762mm)     |
| 4"         | 3 (HDGAF)      | -27CO     | 27" (686mm)     |
| 5"         | 4 (Alum.)      | -24CO     | 24" (610mm)     |
| 6"         | U (304SS)      | -21CO     | 21" (533mm)     |
|            |                | -18CO     | 18" (457mm)     |
|            |                | -15CO     | 15" (381mm)     |
|            |                | -13CO     | 13 1/2" (343mm) |
|            |                | -12CO     | 12" (305mm)     |
|            |                | -10CO     | 10 1/2" (267mm) |
|            |                | -09CO     | 9" (229mm)      |
|            |                | -07CO     | 7 1/2" (191mm)  |
|            |                | -06CO     | 6" (152mm)      |
|            |                | -04CO     | 4 1/2" (114mm)  |
| -03CO      | 3" (76mm)      |           |                 |
| -01CO      | 1 1/2" (38mm)  |           |                 |

**EXAMPLE:** 34-03CO for 3" load depth, aluminum, 3" Reducer Connector. Typical Use: 9" to 6", or use 2 for 12" to 6", etc.

### MATERIAL/FINISH

Electrogalvanized finish standard. Other finishes available; consult factory.

\*Use following suffix when applicable - use only where indicated.

**EG**..... Electrogalvanized carbon steel only

**-SS**..... 302/304 Stainless Steel

**-SS316**.. 316 Stainless Steel (check factory for availability)

*Example:* E-142- 3/8 x 1 1/2 SS, 3/8 x 1 1/2 hex head bolt, 304 stainless steel

### Connector Hardware

(Case-hardened steel electrogalvanized)

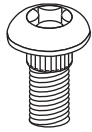

**Part No. 5003-1**  
3/8"-16 x 1" spline bolt



**Part No. 5009-1**  
3/8"-16 hex-flanged nut with serrated washer face.

### Cover Screw [E-150-S]

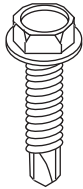

**E-150-S**  
Hex Head Lag Bolt



See Price Sheet for Length.

### Continuous Threaded Rod [H-104]

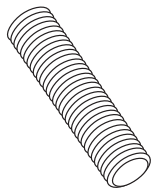

| Size | NATIONAL COARSE THREAD |              |                  |
|------|------------------------|--------------|------------------|
|      | Threads per inch       | lbs./100 ft. | Design Load lbs. |
| 1/4  | 20                     | 12.5         | 150              |
| 3/8  | 16                     | 29           | 610              |
| 1/2  | 13                     | 53.5         | 1130             |
| 5/8  | 11                     | 85           | 1810             |
| 3/4  | 10                     | 123          | 2710             |
| 7/8  | 9                      | 130          | 3770             |
| 1    | 8                      | 214          | 4960             |

### Rod Coupler [H-119]

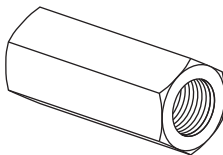

| Prod. #    | Rod Size | A     | Wt./C lbs. |
|------------|----------|-------|------------|
| H-119-1/4  | 1/4      | 1-3/4 | 9          |
| H-119-5/16 | 5/16     | 1-3/4 | 7          |
| H-119-3/8  | 3/8      | 1-3/4 | 10         |
| H-119-1/2  | 1/2      | 1-3/4 | 18         |
| H-119-5/8  | 5/8      | 2-1/8 | 23         |
| H-119-3/4  | 3/4      | 2-1/4 | 21         |
| H-119-7/8  | 7/8      | 2-1/2 | 55         |
| H-119-1    | 1        | 2-3/4 | 68         |

### Hex Nuts [E-145]



**E-145**  
Standard Hex Nut

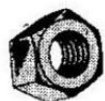

| Size | Wt./C lbs. |
|------|------------|
| 1/4  | .72        |
| 3/8  | 1.06       |
| 1/2  | 2.78       |
| 5/8  | 6.92       |
| 3/4  | 12.70      |
| 7/8  | 19.00      |
| 1    | 26.00      |

### Square Nuts [E-146]

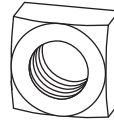

**E-146**  
Standard Square Nut



| Size | Wt./C lbs. |
|------|------------|
| 1/4  | .93        |
| 5/16 | 1.60       |
| 3/8  | 2.65       |
| 1/2  | 5.83       |
| 5/8  | 10.80      |

### Flat Washers [E-147]

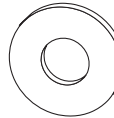

**E-147**  
Flat Steel Washer

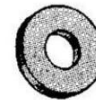

| Size | Wt./C lbs. |
|------|------------|
| 1/4  | .67        |
| 5/16 | 1.11       |
| 3/8  | 1.49       |
| 1/2  | 3.85       |
| 5/8  | 7.69       |
| 7/8  | 15.40      |

### Split-Lock Washers [E-148]

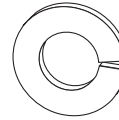

**E-148**  
Lock Washer



| Size | Wt./C lbs. |
|------|------------|
| 1/4  | .26        |
| 5/16 | .39        |
| 3/8  | .50        |
| 1/2  | 1.09       |
| 5/8  | 2.57       |

### Fender Washers [EF-147]

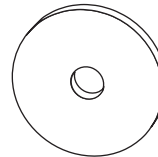

**EF-147**  
Fender Washer

| Size | A     | B    | Wt./C lbs. |
|------|-------|------|------------|
| 1/4  | 1-1/4 | 5/16 | 3.1        |
| 3/8  | 1-1/2 | 7/16 | 2.9        |
| 1/2  | 2     | 9/16 | 5.0        |

### Hex Head Cap Screw / Round Head, Slotted Cap Screw [E-142]

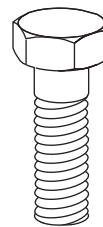

**E-142**  
Hex Head Cap Screw



| Size        | Wt./C lbs. |
|-------------|------------|
| 1/4 x 1     | 1.74       |
| 1/4 x 1-1/2 | 2.43       |
| 3/8 x 1     | 4.17       |
| 3/8 x 1-1/2 | 5.64       |
| 1/2 x 15/16 | 8.94       |
| 1/2 x 1-1/2 | 10.00      |

See Price Sheet For Additional Sizes

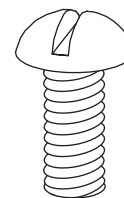

Catalog No. E-141

# HAT CABLE TRAY SYSTEM

**COVERS** for straight sections shown. Standard fitting covers are flat solid type (NF). Aluminum covers are fabricated from 0.040" aluminum AA-3150-H14; steel covers are fabricated from 20 gage ASTM A-653-G90 CQ, mill-galvanized steel.

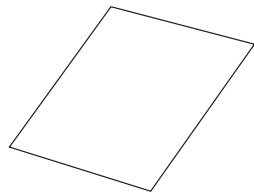

**NF** – Flat Solid

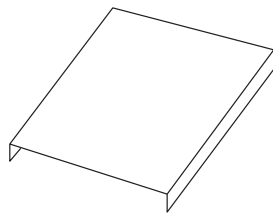

**FS** – Flat Solid  
w/3/8" Flange

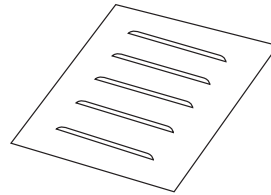

**NL** – Flat Louvered

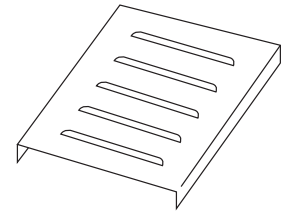

**FL** – Louvered  
w/3/8" Flange

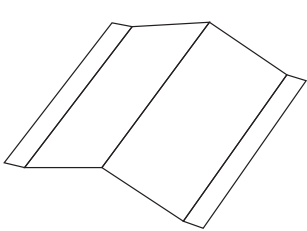

**PS** –Peaked Solid  
(suffix height)

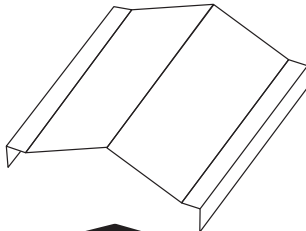

**PF** – Peaked Flanged Solid  
(suffix height)

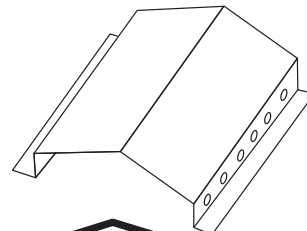

**PV** –Peaked Hat Vent  
**PH** – Peaked Hat Solid  
(suffix height)

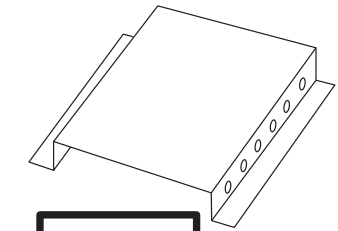

**HS** –Hat Solid  
**HV** –Hat Vent  
(suffix height)

**Note:** Use EM-CC Cover Screws (see pg. 123) to attach PH, PV, HS & HV covers.

**HDGAF** straights only available in 6' sections.

### Cover Catalog Number – Straight Sections

| Type    | Finish         | Basic No. (Width)   | Length | Height* |
|---------|----------------|---------------------|--------|---------|
| HS, HV, | 2 - Mill Galv. | -06SL = 6" (152mm)  | -12'   | -2"     |
| FL, FS, | 3 - HDGAF      | -09SL = 9" (229mm)  | -10'   |         |
| NF, NL, | 4 - Alum.      | -12SL = 12" (305mm) | -06'   |         |
| PS, PF, | U - 304SS      | -18SL = 18" (457mm) |        |         |
| PH, PV  |                | -24SL = 24" (610mm) |        |         |
|         |                | -30SL = 30" (762mm) |        |         |
|         |                | -36SL = 36" (914mm) |        |         |

\*Peak and hat only, 2" height standard. Consult factory for other heights.

**EXAMPLE:** NL2-09SL-12 is a flat louvered mill-galv. steel cover for a 9" wide mill galvanized hat 12' long.

### Cover Catalog Number – Fittings

| Type | Load Depth | Finish         | Width/Basic No. | Radius |
|------|------------|----------------|-----------------|--------|
| NF   | 3          | 2 - Mill Galv. | -06 XX**        | 12"    |
| FS   | 4          | 3 - HDGAF      | -09 XX**        | 24"    |
|      | 5          | 4 - Alum.      | -12 XX**        | 36"    |
|      | 6          | U - 304SS      | -18 XX**        |        |
|      |            |                | -24 XX**        |        |
|      |            |                | -30 XX**        |        |
|      |            |                | -36 XX**        |        |

\*Load depth for outside riser or vertical tee only.

\*\*XX from fitting selection page 108

**EXAMPLE:** NF2-369F-24 is a mill galvanized non-flanged solid cover for a 36" wide horizontal 90° elbow with a 24" radius.

### Joint Plate

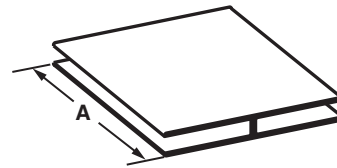

Joint plate is black PVC and is offered in 10' lengths to be field cut to desired length, or in precut lengths for specified covers.

**JP-120** is joint plate in 10' lengths.

Joint plate for specified covers is specified as follows.

| Tray Width          | Flange Type      |
|---------------------|------------------|
| JP-06 = 6" (152mm)  |                  |
| JP-09 = 9" (229mm)  |                  |
| JP-12 = 12" (305mm) | -2=13/16" Flange |
| JP-18 = 18" (457mm) | -4=1 1/4" Flange |
| JP-24 = 24" (610mm) | -7=2" Flange     |
| JP-30 = 30" (762mm) |                  |
| JP-36 = 36" (914mm) |                  |

**EXAMPLE:** JP-06 is a joint plate for 6" wide tray with a 13/16" Flange.

## COVER ACCESSORIES

### Single Side Connector [01CC]



Furnished with 1/4"-28 stainless steel cone point machine screw.

For use with any width tray.

Not sold in pairs.

Suggested spacing:  
Indoor Use Only;  
4 per 12' section

#### Catalog Number [Basic No -01CC]

| Flange                               | Load Depth | Finish         |
|--------------------------------------|------------|----------------|
| 2 - 1 <sup>3</sup> / <sub>16</sub> " | 3          | 2 - Mill Galv. |
| 4 - 1 <sup>1</sup> / <sub>4</sub> "  | 4          | 3 - HDGAF      |
| 5 - 1 <sup>1</sup> / <sub>2</sub> "  | 5          | 4 - Alum.      |
| 7 - 2"                               | 6          | U - 304SS      |

**EXAMPLE:** 234-01CC for 3" load depth, aluminum single side connector.

### Double Clamp Connector [(W) DC]

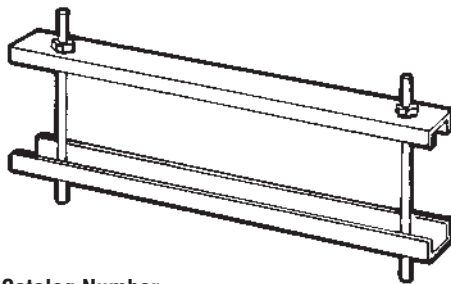

#### Catalog Number

| Load Depth | Finish         | Width | Type |
|------------|----------------|-------|------|
| 3          | 2 - Mill Galv. | -06   | DC   |
| 4          | 3 - HDGAF      | -09   |      |
| 5          | 4 - Alum.      | -12   |      |
| 6          | U - 304SS      | -18   |      |
|            |                | -24   |      |
|            |                | -30   |      |
|            |                | -36   |      |

For all covers except hat & peak type. Furnished with:  
(2) 1/4"-20 all-thread rods  
(4) hex nuts, flat washers and lock washers

Suggested spacing:  
Indoor: 2 per 12'  
Outdoor: 3 per 12'  
High Wind: 5 per 12'

**EXAMPLE:** 34-12DC for 3" load depth, aluminum, Double Clamp Connector

### Peak Cover Connector [PC]

**Note:** For PS & PF Cover

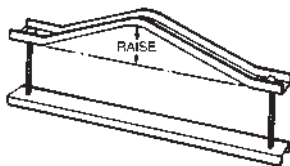

#### Catalog Number

| Load Depth | Finish         | Width | Type | Raise (in)* |
|------------|----------------|-------|------|-------------|
| 3          | 2 - Mill Galv. | -06   | PC   | -2          |
| 4          | 3 - HDGAF      | -09   | VC   |             |
| 5          | 4 - Alum.      | -12   |      |             |
| 6          | U - 304SS      | -18   |      |             |
|            |                | -24   |      |             |
|            |                | -30   |      |             |
|            |                | -36   |      |             |

\*2" standard raise. Consult factory for other peak heights.

**EXAMPLE:** 34-12VC-2 for 3" load depth, aluminum, 12" wide, Peak Cover Connector (vented cover) with 2" peak.

### Peak Vent Cover Connector [VC]

**Note:** For PV Covers

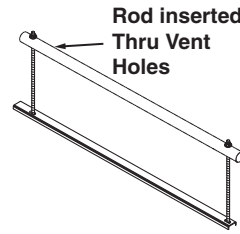

#### Catalog Number

| Flange                             | Load Depth | Finish       | Width | Type |
|------------------------------------|------------|--------------|-------|------|
| 2=1 <sup>3</sup> / <sub>16</sub> " | 3          | 6=Mill Galv. | -06   | VC   |
| 4=1 <sup>1</sup> / <sub>4</sub> "  | 4          | 7=HDGAF      | -09   |      |
| 5=1 <sup>1</sup> / <sub>2</sub> "  | 5          | 8=Alum.      | -12   |      |
| 6=1 <sup>3</sup> / <sub>4</sub> "  | 6          | T=304SS      | -18   |      |
|                                    |            |              | -24   |      |
|                                    |            |              | -30   |      |
|                                    |            |              | -36   |      |

**EXAMPLE:** 238-12VC for 3" load depth, 1<sup>3</sup>/<sub>16</sub>" flange, aluminum, 12" wide, Peak Vented Cover Connector

### Cover Connector [CC]

**Note:** For all covers except hat & peak type

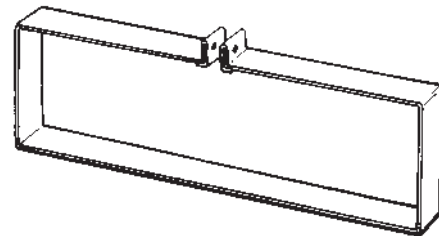

#### Catalog Number

| Load Depth | Finish         | Width | Type |
|------------|----------------|-------|------|
| 3          | 2 - Mill Galv. | -06   | CC   |
| 4          | 3 - HDGAF      | -09   |      |
| 5          | 4 - Alum.      | -12   |      |
| 6          | U - 304SS      | -18   |      |
|            |                | -24   |      |
|            |                | -30   |      |
|            |                | -36   |      |

**EXAMPLE:** 34-12CC for aluminum, 12" wide Connector

### Elevated Cover Connectors [EM-CC]

HDGAF for Outdoor Use

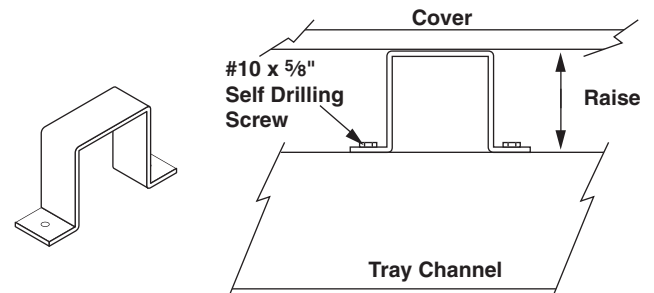

#### Catalog Number

| Finish         | Type  | Height*        |
|----------------|-------|----------------|
| 2 - Mill Galv. | EM-CC | - Raise* (in.) |
| 3 - HDGAF      |       |                |
| 4 - Alum.      |       |                |
| U - 304SS      |       |                |

Includes:

(3) #10 x 5/8" Self drilling screws.

Suggested spacing:

Indoor: 3/Side (6 tot.) per 12';

\*1", 2" or 3" standard.

**EXAMPLE:** 3-EM-CC-2 for hot dipped galvanized, Elevated Cover Connector with a 2" raise

# HAT CABLE TRAY SYSTEM



## ACCESSORIES

### Drop Out [DO]

14 Gage Steel, .080" Aluminum

**NOTE:** (2) #10 x 5/8" self tapping screws furnished.

| Catalog Number |             |         |
|----------------|-------------|---------|
| Basic Finish   | Width       |         |
| 2 (Mill Galv.) | -06DO = 6"  | (152mm) |
| 3 (HDGAF)      | -09DO = 9"  | (229mm) |
| 4 (Alum.)      | -12DO = 12" | (305mm) |
| U (304SS)      | -18DO = 18" | (457mm) |
|                | -24DO = 24" | (610mm) |
|                | -30DO = 30" | (762mm) |
|                | -36DO = 36" | (914mm) |

**EXAMPLE:** 4-12DO for aluminum, 12" wide, Drop Out.

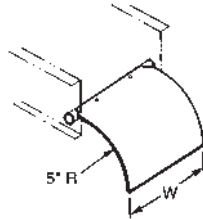

### Blind End [BE]

22 Gage Steel, .040" Aluminum

**NOTE:** 3/8"-16 spline bolts and flange nuts furnished.

| Catalog Number |                |                     |
|----------------|----------------|---------------------|
| Load Depth     | Finish         | Width               |
| 3              | 2 (Mill Galv.) | -06BE = 6" (152mm)  |
| 4              | 3 (HDGAF)      | -09BE = 9" (229mm)  |
| 5              | 4 (Alum.)      | -12BE = 12" (305mm) |
| 6              | U (304SS)      | -18BE = 18" (457mm) |
|                |                | -24BE = 24" (610mm) |
|                |                | -30BE = 30" (762mm) |
|                |                | -36BE = 36" (914mm) |

**EXAMPLE:** 34-12BE for 3" load depth, aluminum, 12" wide Blind End.

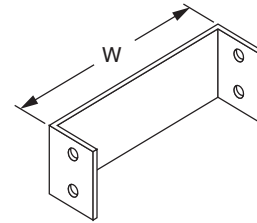

### Box Connector [CB]

14 Gage Steel  
.080" Aluminum

**NOTE:** 1/4"-20 carriage bolts, flat washers, hex nuts furnished.

| Catalog Number |                |                     |
|----------------|----------------|---------------------|
| Load Depth     | Finish         | Width               |
| 3              | 2 (Mill Galv.) | -06CB = 6" (152mm)  |
| 4              | 3 (HDGAF)      | -09CB = 9" (229mm)  |
| 5              | 4 (Alum.)      | -12CB = 12" (305mm) |
| 6              | U (304SS)      | -18CB = 18" (457mm) |
|                |                | -24CB = 24" (610mm) |
|                |                | -30CB = 30" (762mm) |
|                |                | -36CB = 36" (914mm) |

**EXAMPLE:** 34-12CB for 3" load depth, aluminum, 12" wide, Box Connector.

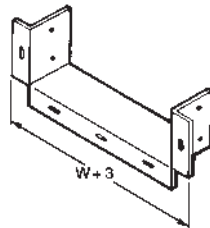

### Bonding Jumper [CBJ]

| Catalog No. | Dimensional Data                            | Amperes as Equipment Ground |
|-------------|---|-----------------------------|
| CBJ-C       | AWG 1/0 copper wire<br>15 1/2" long overall | 800 amperes                 |
| CBJ-4C      | AWG 4/0 copper wire<br>15 1/2" long overall | 1,600 amperes               |
| CBJ-250C    | 250 MCM copper wire<br>15 1/2" long overall | 2,000 amperes               |

**NOTE:**

No hardware supplied

For hardware kit add -HDW:

Ex: CBJ-C-HDW includes  
2ea CBJ-C  
4ea 5003-1  
4ea 5009-1

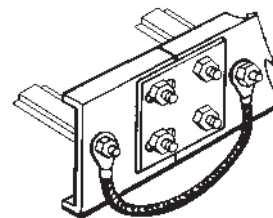

### Cable Tray Ground Clamp [9156]

Extruded Alum. with ElectroGalvanized Hex Head Screws

Capacity: #6 AWG to 250 kcmil

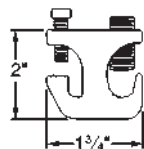
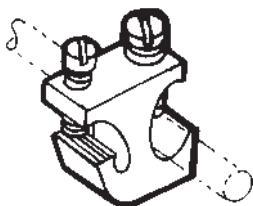

### Ground Cable Retainer Clamp

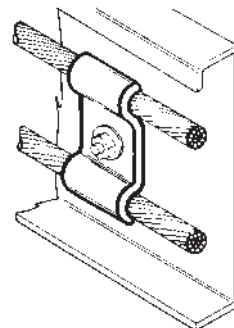

| Catalog No. | Capacity    | Metal & Finish      | Dimensions         |
|-------------|-------------|---------------------|--------------------|
| 9056-EP     | 1/0 2/0 3/0 | Electro-Galv. Steel | 1" w x 2" long     |
| 9057-EP     | 4/0 250 MCM |                     | 1" w x 2 3/8" long |
| 9056-SS     | 1/0 2/0 3/0 | Stainless Steel     | 1" w x 2" long     |
| 9057-SS     | 4/0 250 MCM |                     | 1" w x 2 3/8" long |

### Conduit Clamp Bracket

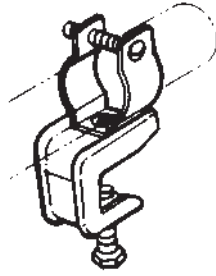

| Catalog No. | Size-Rigid   | Size-EMT |
|-------------|--------------|----------|
| CCB-050     | 3/8" to 1/2" | 1/2"     |
| CCB-075     | 3/4"         | 3/4"     |
| CCB-100     | 1"           | 1"       |
| CCB-125     | -            | 1 1/4"   |
| CCB-150     | 1 1/4"       | 1 1/2"   |
| CCB-200     | 2"           | 2"       |

### Conduit-to-Cable Tray Clamp - Swivel Type

Malleable iron hub and steel "U" bolt. For connecting and grounding rigid conduit to tray at any angle within 90° arc. U.L. listed as a grounding means.

| Catalog No. | Size      | Std. Pkg. |
|-------------|-----------|-----------|
| TB6209      | 1/2"-3/4" | 10        |
| TB6211      | 1"-1 1/4" | 10        |
| TB6214      | 1 1/2"-2" | 5         |
| TB6216      | 2 1/2"-3" | 5         |
| TB6218      | 3 1/2"-4" | 2         |

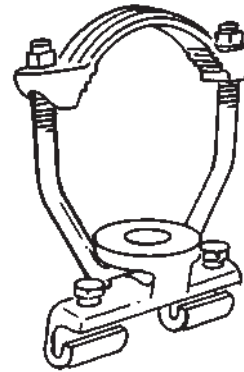

### Wall Penetrating Sleeve Assembly [SS89042(W) \*]

W = Tray Width  
 \*=Fitting 3-Digit Prefix

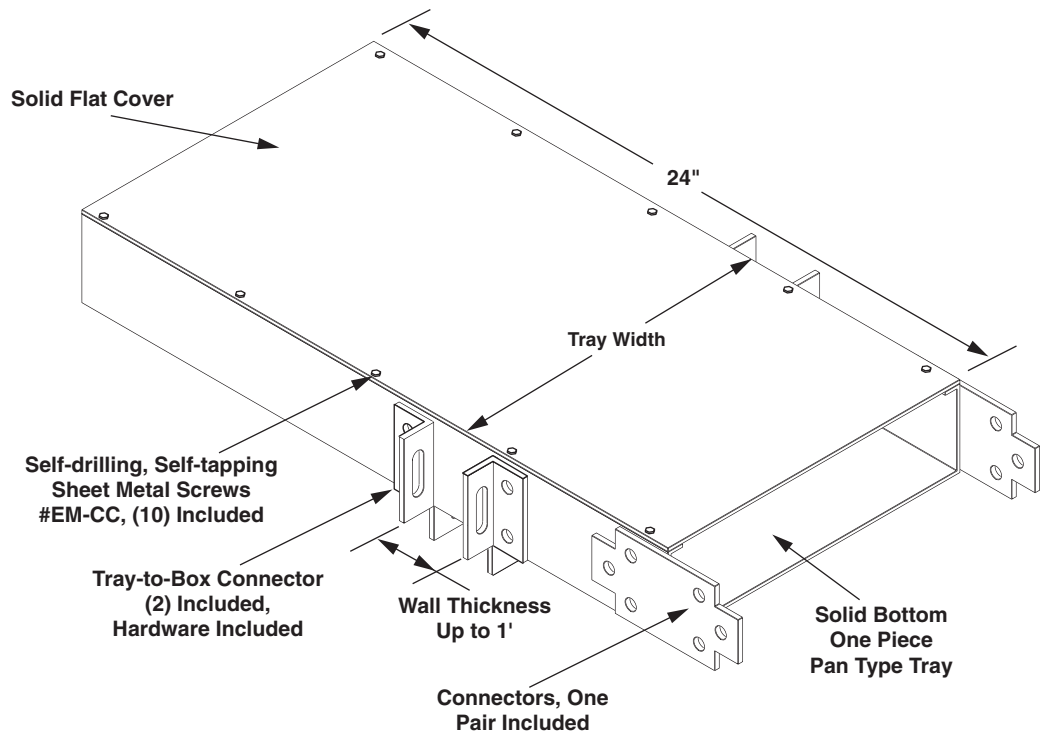

**Note:** Standard penetration sleeves are manufactured from mill galvanized steel. Aluminum sleeves are available upon request.

# HAT CABLE TRAY SYSTEM

## BARRIER STRIPS

### Universal Aluminum Barrier Strip - Straight Section [SB]

| Catalog Number |           |                      |
|----------------|-----------|----------------------|
| Load Depth     | Finish    | Basic No. 12' Length |
| 3              | A (Alum.) | -01SB-12             |
| 4              |           |                      |
| 5              |           |                      |
| 6              |           |                      |

**EXAMPLE:** 3A-01SB-12 for 3" load depth, aluminum straight barrier, 12' long.

Furnished with 8 self tapping screws.

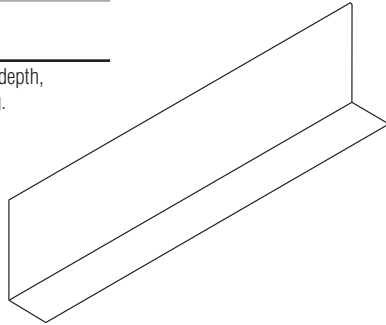

### Barrier Strip—Straight Section [SB]

| Catalog Number |                |                      |
|----------------|----------------|----------------------|
| Load Depth     | Finish         | Basic No. 12' Length |
| 3              | 2 (Mill Galv.) | -01SB-12             |
| 4              | 3 (HDGAF)      |                      |
| 5              | 4 (Alum.) *    |                      |
| 6              | U (304 SS)     |                      |

**EXAMPLE:** 34-01SB-12 for 3" load depth, aluminum straight barrier, 12' long.

Furnished with 8 self tapping screws.

\* Long lead time item - See Universal aluminum barrier strip to the left

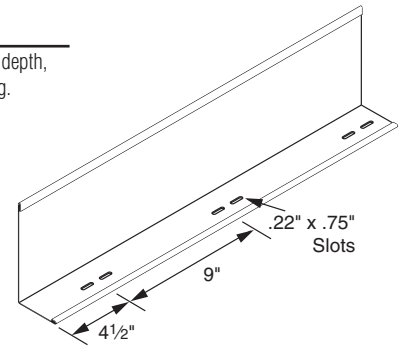

### Barrier Strip—Horizontal Fitting [FB]

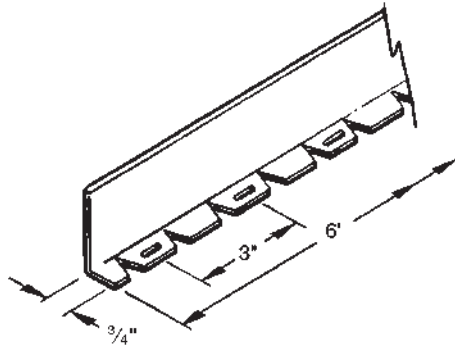

| Catalog Number |                |                     |
|----------------|----------------|---------------------|
| Load Depth     | Finish         | Basic No. 6' Length |
| 3              | 2 (Mill Galv.) | -01FB-06            |
| 4              | 3 (HDGAF)      |                     |
| 5              | 4 (Alum.)      |                     |
| 6              | U (304 SS)     |                     |

**EXAMPLE:** 34-01FB-06 for 3" load depth, aluminum fitting barrier, 6' long.  
Furnished with 4 self tapping screws.

### Barrier Strip Vertical Elbow Outside [OB] & Inside [IB]

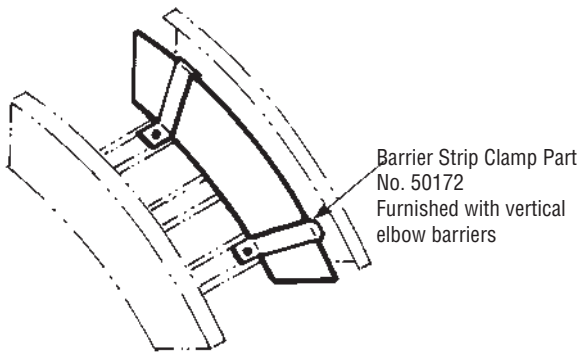

| Catalog Number |                |             |              |             |
|----------------|----------------|-------------|--------------|-------------|
| Load Depth     | Finish         | Bend (deg.) | Basic No.    | Radius      |
| 3              | 2 (Mill Galv.) | 90          | OB = Outside | 12" (305mm) |
| 4              | 3 (HDGAF)      | 60          | IB = Inside  | 24" (610mm) |
| 5              | 4 (Alum.)      | 45          |              | 36" (914mm) |
| 6              | U (304 SS)     | 30          |              |             |

**EXAMPLE:** 34-90OB-12 for 3" load depth, aluminum 90° outside vertical barrier with 12" radius. (OB Vert. Elbow outside shown)  
Furnished with sufficient clamp assemblies for installation.  
Additional clamp assemblies may be ordered separately.

### Nylon Barrier Splice & Protector [BSP-L]

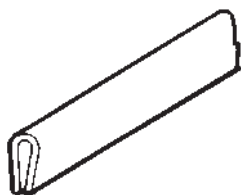

| Catalog Number |                       |
|----------------|-----------------------|
| Prefix         | Length (L)            |
| BSP            | -5 (5' Splice)        |
|                | -144 (144" Protector) |
|                | -1200 (100' Roll)     |

**EXAMPLE:** BSP-1200 for 100' roll

### Cover Screw

Part No. EM-CC (electro galv. steel)  
Part No. EM-CC-SS (stainless steel)

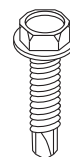

No. 10 x 5/8" long, self drilling-self tapping hex head plated steel screw.  
Suggested spacing: Indoor: 8 per 12'; Outdoor: 10 per 12'

### Barrier Strip Clamp (Optional) [50172]

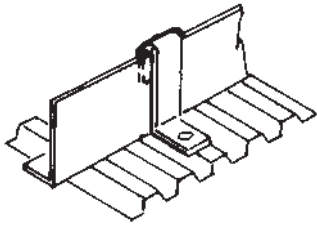

No. 10 bolt, nut, washer and lock washer furnished.

| Catalog Number |                |           |
|----------------|----------------|-----------|
| Load Depth     | Finish         | Basic No. |
| 3              | 2 (Mill Galv.) | -50172    |
| 4              | 3 (HDGAF)      |           |
| 5              | 4 (Alum.)      |           |
| 6              | U (304 SS)     |           |

*EXAMPLE:* 34-5072 for 3" load depth, aluminum clamp.

### Hold-Down Clamp & Expansion Guide

(For expansion guide clamp, add suffix "EX" to catalog number.)

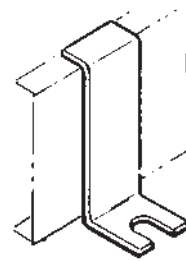

| Catalog Number |                           |
|----------------|---------------------------|
| Load Depth     | Basic No.                 |
| 3              | -9039 (Aluminum)          |
| 4              | -9040 (ElectroGalv.Steel) |
| 5              | -9041 (HDGAF)             |
| 6              | -9042 (316SS)             |

*EXAMPLE:* 3-9039-EX for 3" load depth, expansion guide.

Hardware purchased separately to suit support system.

Complete Kit add "-HDW" to Part Number above.

Hardware Kit List:

- (2) Hold-Down Clamps
- (2) 1/2" - 13 x 1 1/2" Cap Screws
- (2) 1/2" Flat Washer
- (2) Clamping Nut (Strut Nut)

### Hold-Down [9132]

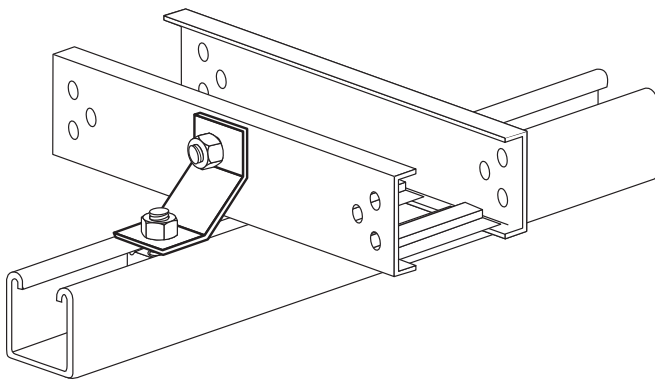

| Catalog No. | Material        |
|-------------|-----------------|
| 9132        | Mill Galvanized |
| 9133        | Stainless Steel |

Hardware purchased separately to suit support system.

**Note:** For seismic applications or other bolted connections is preferred.

### Isolation Pad [PVC-PAD]

The Isolation pad provides protection from galvanic corrosion when Aluminum tray is mounted on steel supports.

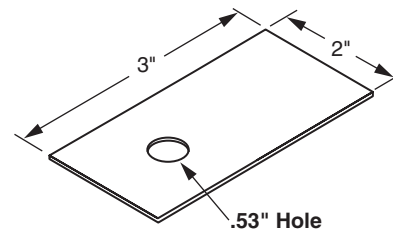

The PVC-PAD is a 2"x3" plain isolation pad with no hole.

**Note:** For use with the 9039 series of Hold-Down Clamp & Expansion Guide. Hardware purchased separately

# HAT CABLE TRAY SYSTEM



## SUPPORT BRACKETS

### Gusset-Type Supports

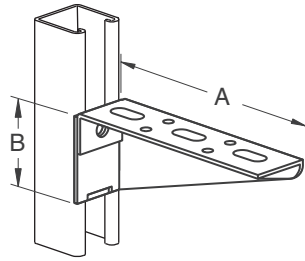

For use with all types of AB-Cope Ladder and Trof systems. Finish is electro-galvanized. Order hardware separately.

| Catalog No. | Ladder Width | Dimension |                                   | Uniform-Load Rating |
|-------------|--------------|-----------|-----------------------------------|---------------------|
|             |              | A         | B                                 |                     |
| PS 838R-6   | -            | 6"        | 1 <sup>15</sup> / <sub>16</sub> " | 275 lbs.            |
| PS 838R-8   | -            | 8"        | 2 <sup>7</sup> / <sub>16</sub> "  | 275 lbs.            |
| PS 838R-10  | -            | 10"       | 2 <sup>15</sup> / <sub>16</sub> " | 275 lbs.            |
| PS 838R-12  | 6"           | 12"       | 3 <sup>7</sup> / <sub>16</sub> "  | 275 lbs.            |
| PS 838R-16  | 9"           | 16"       | 4 <sup>7</sup> / <sub>16</sub> "  | 275 lbs.            |
| PS 838R-18  | 12"          | 18"       | 4 <sup>15</sup> / <sub>16</sub> " | 275 lbs.            |
| PS 838R-24  | 18"          | 24"       | 6 <sup>7</sup> / <sub>16</sub> "  | 275 lbs.            |
| PS 838R-30  | 24"          | 30"       | 7 <sup>15</sup> / <sub>16</sub> " | 275 lbs.            |

### Channel-Type Supports

For use with all types of AB-Cope Ladder and Trof systems. Finish is electro-galvanized. Order hardware separately.

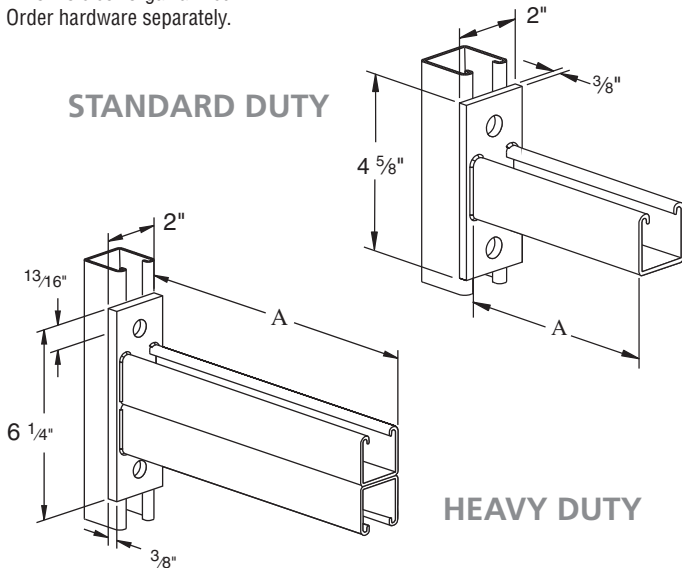

#### Standard Duty for Lighter Loads.

| Catalog No. | Ladder Width | Dimension A | Uniform-Load Rating* |
|-------------|--------------|-------------|----------------------|
| PS 651-6    | -            | 6"          | 1,200 lbs.           |
| PS 651-12   | 6"           | 12"         | 600 lbs.             |
| PS 651-15   | 9"           | 15"         | 480 lbs.             |
| PS 651-18   | 12"          | 18"         | 400 lbs.             |
| PS 651-24   | 18"          | 24"         | 300 lbs.             |
| PS 651-30   | 24"          | 30"         | 240 lbs.             |

\* Mounted on 12 Ga. Channel.

#### Heavy Duty for Heavier Loads

| Catalog No. | Ladder Width | Dimension A | Uniform-Load Rating* |
|-------------|--------------|-------------|----------------------|
| PS 809-12   | 6"           | 12"         | 2,000 lbs.           |
| PS 809-15   | 9"           | 15"         | 1,600 lbs.           |
| PS 809-18   | 12"          | 18"         | 1,330 lbs.           |
| PS 809-24   | 18"          | 24"         | 1,000 lbs.           |
| PS 809-30   | 24"          | 30"         | 800 lbs.             |
| PS 809-36   | 30"          | 36"         | 660 lbs.             |
| PS 809-42   | 36"          | 42"         | 570 lbs.             |

\* Mounted on 12 Ga. Channel.

### Wall Support Brackets

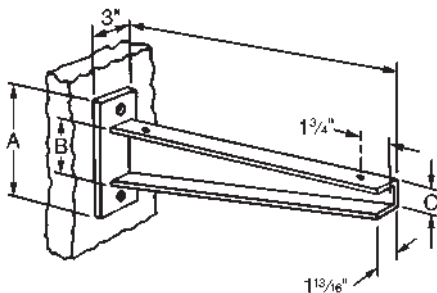

| Catalog No. | Tray Width | Length "L"                       | Dimensions |     |                                 | End-Load Rating* |
|-------------|------------|----------------------------------|------------|-----|---------------------------------|------------------|
|             |            |                                  | "A"        | "B" | "C"                             |                  |
| 9037-12     | 6"         | 12 <sup>1</sup> / <sub>4</sub> " | 10"        | 6"  | 2"                              | 2000 lbs.        |
| 9037-18     | 12"        | 18 <sup>1</sup> / <sub>4</sub> " | 11"        | 7"  | 2 <sup>1</sup> / <sub>2</sub> " | 2000 lbs.        |
| 9037-24     | 18"        | 24 <sup>1</sup> / <sub>4</sub> " | 11"        | 7"  | 2 <sup>1</sup> / <sub>2</sub> " | 1600 lbs.        |
| 9037-30     | 24"        | 30 <sup>1</sup> / <sub>4</sub> " | 12"        | 8"  | 4"                              | 1300 lbs.        |
| 9037-36     | 30"        | 36 <sup>1</sup> / <sub>4</sub> " | 12"        | 8"  | 4"                              | 1100 lbs.        |
| 9037-42     | 36"        | 42 <sup>1</sup> / <sub>4</sub> " | 12"        | 8"  | 4"                              | 900 lbs.         |

\*Uniform load rating is normally twice the end-load rating.

Finish is hot-dip galvanized after fabrication. Order hardware separately.

### Structural Support Bracket

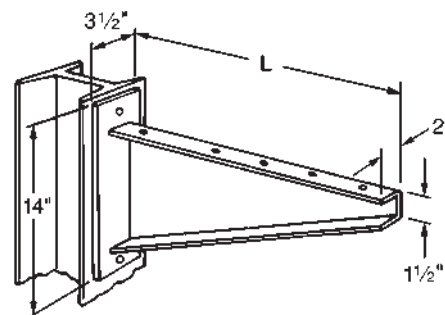

| Catalog No. | Tray Width | Length "L"                       | End-Load Rating* |
|-------------|------------|----------------------------------|------------------|
| 9036-31     | 24"        | 31 <sup>1</sup> / <sub>4</sub> " | 2000 lbs.        |
| 9036-37     | 30"        | 37 <sup>1</sup> / <sub>4</sub> " | 1800 lbs.        |
| 9036-45     | 36"        | 45 <sup>1</sup> / <sub>4</sub> " | 1500 lbs.        |

\*Uniform load rating is normally twice the end-load rating.

For use with Trof 24" or wider. May be welded or bolted to building steel. Finish is hot-dip galvanized after fabrication. Order hardware separately.

### Vertical Supports

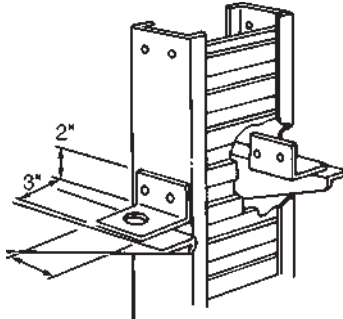

| Cat. No. | For Use With                                |
|----------|---|
| 9045     | 3 1/4" Overall Height Side Members          |
| 9043-37  | 4 1/4" Overall Height Side Members          |
| 9043     | 5 1/4" Overall Height Side Members          |
| 9025-98  | 6 1/4" & 7 1/4" Overall Height Side Members |

Tray Supports can be bolted anywhere along the straight runs. They can be bolted directly onto the coupler plates at splices of straight runs and riser fittings, or they can be bolted at any place in the run by field-drilling side rails. TROF supports are used with either 3/8" or 1/2" hanger rods. Finish is electrogalvanized.

### Single Rod Hanger Support

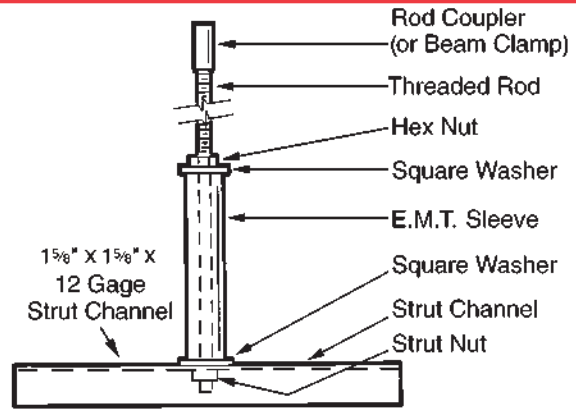

Catalog Number

| Assy. Type | Channel Length* | Channel Finish**     | Rod Diameter     | Rod Length          | Beam Clamp      |
|------------|-----------------|----------------------|------------------|---------------------|-----------------|
| P200       | 14" (356mm)     | GV (Pre-Galv)        | 38=3/8" (9.53mm) | 000 - No Rod        | A - PS 85       |
|            | 17" (432mm)     | HG (Hot Dipped Galv) | 12=1/2" (12.7mm) | 036 - 36" (914mm)   | B - P2622       |
|            | 20" (508mm)     |                      |                  | 072 - 72" (1828mm)  | O - No Clamp    |
|            | 26" (661mm)     |                      |                  | 120 - 120" (3048mm) | R - Rod Coupler |
|            | 32" (813mm)     |                      |                  | 144 - 144" (3658mm) | S - Special     |
|            | 38" (966mm)     |                      |                  |                     |                 |
|            | 44" (1118mm)    |                      |                  |                     |                 |

**EXAMPLE:** P20020GV12036B is a Single 20" pre-galvanized channel with 1/2" x 36" drop rod and P2622 clamp.

**NOTE:**

\*Order channel length 8" longer than tray width. For example, 44" channel for 36" tray.

\*\* Other channel types and finishes available upon request. Contact factory.

To order hardware only: 3/8" - PGV380000, 1/2" - PGV120000

AB-COPE HAT

### Trapeze Hanger Support

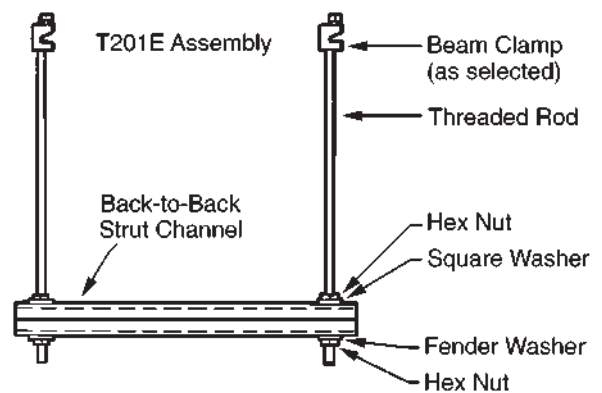
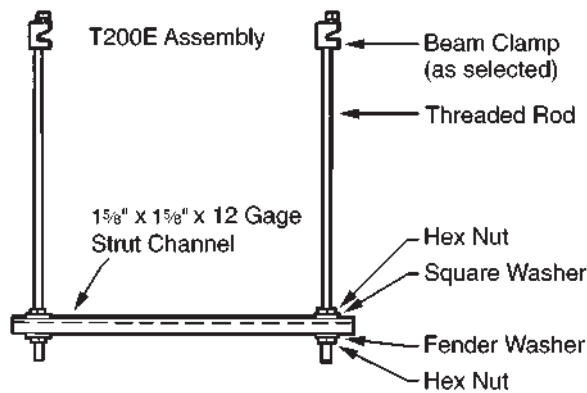

Catalog Number

| Assy. Type | Channel Length* | Channel Finish**     | Rod Diameter     | Rod Length          | Beam Clamp      |
|------------|-----------------|----------------------|------------------|---------------------|-----------------|
| T200E      | 16" (407mm)     | GV (Pre-Galv)        | 38=3/8" (9.53mm) | 000 - No Rod        | A - PS 85       |
| T201E      | 19" (483mm)     | HG (Hot Dipped Galv) | 12=1/2" (12.7mm) | 036 - 36" (914mm)   | B - P2622       |
|            | 22" (559mm)     |                      |                  | 072 - 72" (1828mm)  | O - No Clamp    |
|            | 28" (712mm)     |                      |                  | 120 - 120" (3048mm) | R - Rod Coupler |
|            | 34" (864mm)     |                      |                  | 144 - 144" (3658mm) | S - Special     |
|            | 40" (1017mm)    |                      |                  |                     |                 |
|            | 46" (1169mm)    |                      |                  |                     |                 |

**EXAMPLE:** T200E22GV12036B is a Single 22" pre-galvanized channel with 1/2" x 36" drop rod and P2622 clamp.

**NOTE:** \*Order channel length 10" longer than tray width. For example, 46" channel for 36" tray.

\*\* Other channel types and finishes available upon request. Contact factory.

To order hardware only: 3/8" - PGV380000, 1/2" - PGV120000

## Electrical Grounding Chart

Table 1 below provides the Minimum Cross Sectional area for two side rails. Using the Fitting Prefix Number (24A), the proper value is determined by the Material (column 3), the Flange Width (column 1) and Load Depth (column 2). Locate the line containing the Load Depth (column 1) and follow it to the right to the appropriate Flange Width and Material.

**TABLE 1**

| Fitting Prefix Number               |            |              | Min. X-Sect for 2 Rails (NEC® Table 392.7B) |  |  |  |
|-------------------------------------|------------|--------------|---|--|--|--|
|                                     |            |              | Aluminum                                    |  | Steel                                  |  |
|                                     |            |              | <sup>13</sup> / <sub>16</sub> " Flange      | 1 <sup>1</sup> / <sub>4</sub> " Flange | <sup>13</sup> / <sub>16</sub> " Flange | 1 <sup>1</sup> / <sub>4</sub> " Flange |
| Flange                              | Load Depth | Material     | X-Sect Area                                 | X-Sect Area                            | X-Sect Area                            | X-Sect Area                            |
| 2 - <sup>13</sup> / <sub>16</sub> " | 3"         | P - Mill Gal | 0.60  | -                                      | 0.40                                   | -                                      |
| 4 - 1 <sup>1</sup> / <sub>4</sub> " | 4"         | G - HDGAF    | 0.60  | 0.60                                   | 0.40                                   | 0.70                                   |
|                                     | 5"         | A - Alum.    | 0.60  | 1.00                                   | 0.70                                   | 0.70                                   |
|                                     | 6"         |              | 0.60  | 1.00                                   | 0.70                                   | 1.00                                   |

Find that value in Table 2, follow it to the right to the Material column to determine the Maximum Ground Fault Amperage.

**TABLE 2**

| X-Sect Area | Maximum Ground Fault Amperage (in Amps) |       |
|-------------|---|-------|
|             | Material                                |       |
|             | Aluminum                                | Steel |
| .40 sq in   | -                                       | 100   |
| .60 sq in   | 1000                                    | -     |
| .70 sq in   | -                                       | 200   |
| 1.00 sq in  | 1200                                    | 400   |

**For Example:**

If the fitting prefix is 24A, the Flange is <sup>13</sup>/<sub>16</sub>", the Load Depth is 4", and the Material is Aluminum. The Minimum Cross Sectional Area (X-Sect Area) is 0.60 sq. in. The Amperage is 1000.

## Typical Specifications

By specifying the NEMA class designation, you will use the simplest, clearest, and most complete method of specification available and automatically incorporate support span in feet, working (allowable) load in pounds per linear foot, a safety factor of 1.5, a concentrated load if present, and, all other design, manufacturing, and test standards including electrical continuity.

All you need to do is add the desired load depth, rung spacing, radius of fittings, metal and finish. You may add accessory information pursuant to your project. Here is a typical specification for an outdoor tray system where the working (allowable) load has been determined to be approximately 75 pounds per foot on support spans of 12'-0".

## SPECIFICATION - AB-COPE HAT LADDER SYSTEM

Cable Hat Ladder shall be manufactured by a company regularly engaged in the manufacture of metal cable trays and shall be a member of NEMA. Trays shall conform to NEMA Metal Cable Tray Standard Publication VE-1 (latest issue).

- Cable ladder shall be NEMA Classification 12B of the widths indicated.
- Material shall be aluminum alloy 6063-T6 for side rails and 5052-H34 for rungs.
- Finish shall be natural.
- Inside load depth to be NEMA Standard 4".
- Fittings shall be 12" radius for control cables and 24" radius for power cables. (This must be commensurate with the cable manufacturer's recommended minimum bending radius.)
- All top level trays in stacks, and single runs to have raised peaked, aluminum ventilated covers with heavy duty hold down clamps every 3'-0"
- Install expansion connectors, expansion guides, and hold down clamps per NEMA Standard VE-1.
- Where slopes or horizontal bends of trays are not at the Standard NEMA angles, use adjustable connectors. If the angle is too great for cable bending radius, use combinations of fitting and adjustable connectors.
- Separate all cables of different voltages in the same tray using the manufacturer's standard barriers and barrier hold down system.
- The Cable Hat Ladder system will be used as an equipment grounding conductor.
- To save space, fittings shall have no tangents. To facilitate field installation use one pair of universal type connector plates for rigid joints.
- Cable Ladder to have hat type rungs arc welded to side rails. Rungs shall not protrude below side rails. Outside depth shall not exceed inside depth by more than <sup>5</sup>/<sub>8</sub>". Side rails to have flanges facing in. Trays shall be AB-Cope Hat Ladder System No. 3B4A as manufactured by AB-Cope standard design.



# AB-COPE™ TROF

# 6



**Corrugated Bottom Cable TROF System for Power,  
Control, Instrumentation Cable, & Pneumatic Tubing**

## CONTENTS

### General and Technical Information

|   |           |
|---|-----------|
| Selection Chart: Cope Trof - Aluminum ..... | 137 - 138 |
| Selection Chart: Cope Trof - Steel.....     | 139 - 140 |
| Overview .....                              | 141       |
| Ordering Information.....                   | 142       |
| CSA Selection Chart: Aluminum/Steel .....   | 143       |
| CSA Ordering Information.....               | 144       |
| Straight Length.....                        | 145       |

### AB-Cope Trof Fittings

|                                       |                |
|---------------------------------------|----------------|
| Horizontal Elbows                     |                |
| 90°.....                              | 146            |
| 60°.....                              | 146            |
| 45°.....                              | 147            |
| 30°.....                              | 147            |
| Horizontal Tee.....                   | 148 - 150      |
| Horizontal Cross .....                | 148, 151 - 152 |
| Straight Reducers .....               | 153            |
| Left and Right Hand Reducers .....    | 153            |
| Adjustable Elbow .....                | 154            |
| 45° "Y" Branch .....                  | 154            |
| Vertical Elbows (Inside and Outside)  |                |
| 90°.....                              | 155            |
| 60°.....                              | 154            |
| 45°.....                              | 156            |
| 30°.....                              | 156            |
| 90° Vertical Cable Support Elbow..... | 157            |
| Vertical Tee .....                    | 157            |

### Connectors & Hardware

|   |     |
|---|-----|
| Universal Curvilinear Connector, Expansion,<br>Horizontal and Vertical Adjustable, Reducing and 90° Connector ..... | 158 |
| General Hardware .....  | 159 |

### Covers

|  |     |
|--|-----|
| Covers, Joint Plate .....  | 160 |
| Cover Attachments (Hold Down Clamps,<br>Elevated and Peaked Cover Connectors)..... | 161 |

### Accessories

|  |           |
|--|-----------|
| Blind End, Drop Out, Bonding Jumper, Box Connector,<br>Cable Tray Ground Clamp, Ground Cable Retainer Clamp..... | 162       |
| Conduit Clamp, Wall Sleeve .....   | 163       |
| Barrier Strips, Nylon Protector.....   | 164       |
| Hold Down Clamp & Expansion Guide,<br>Seismic Hold Down, Barrier Strip Clamps.....                               | 165       |
| Channel Supports, Tray Brackets, Support Brackets.....   | 166 - 167 |
| Hanger Support, Trapeze Hanger Support, Vertical Supports.....   | 167 - 168 |

### Specification Information

|                                 |     |
|---------------------------------|-----|
| Electrical Grounding Chart..... | 168 |
| Typical Specification.....      | 169 |

## Straight Length

Page 145

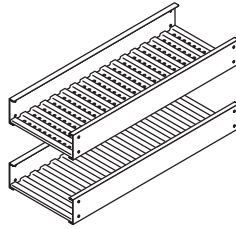

## Horizontal Elbows

Pages 146 - 147

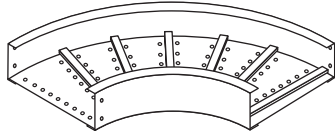

## Horizontal Tee

Page 148 - 150

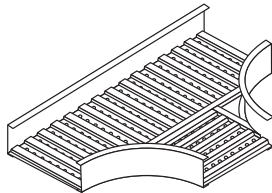

## Horizontal Cross

Page 148, 151 - 152

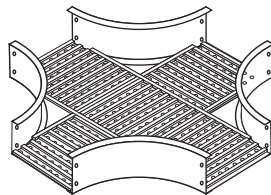

## Reducers

Page 153

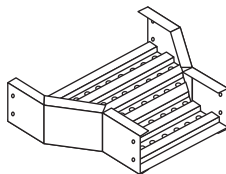

## Adjustable Elbows

Page 154

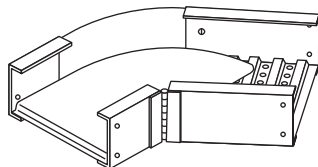

## 45° "Y" Branch

Page 154

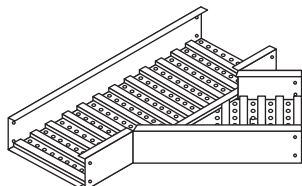

## Vertical Elbows

Pages 155 - 156

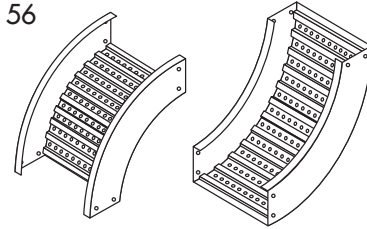

## 90° Vertical Cable Support Elbow

Page 157

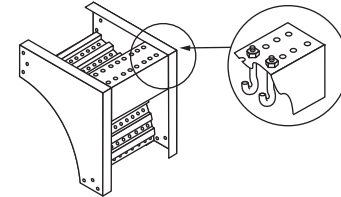

## Vertical Tee

Page 157

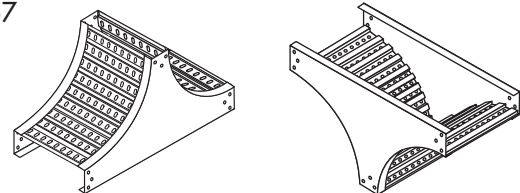

## Connectors

Pages 158 - 159

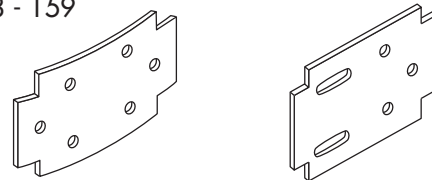

## Covers

Page 160

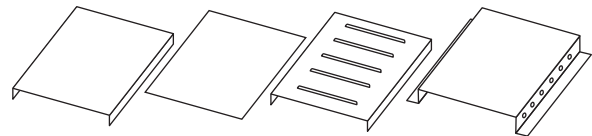

## Cover Attachments

Page 161

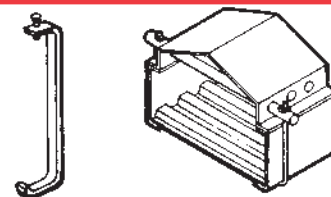

## Barrier Strips & Accessories

Pages 162 - 168

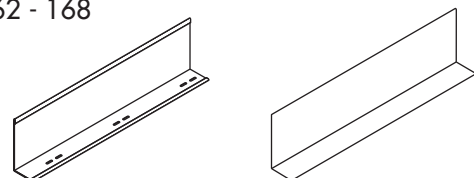

# TROF CABLE TRAY SYSTEM



## SELECTION CHART: Aluminum Tray

### NEMA CLASS, PHYSICAL AND STRUCTURAL PROPERTIES

| NEMA Standard VE-1 Load/Span Class   | NEMA Load/Span          | Cope System Number | Cope Systems Certified by CSA | Nominal Load Depth | Side Rail Height | Flange Width (in.) | Section Modulus of 2 Rails Sx (in. <sup>3</sup> ) | Moment of Inertia for 2 Rails Ix (in. <sup>4</sup> ) | Min X-Sect. Area of 2 Rails per NEC 392.7 (in. <sup>2</sup> ) |
|--|-------------------------|--------------------|-------------------------------|--------------------|------------------|--------------------|---|--|---|
| 8A-12A   | 50 lb./ft.<br>12' span  | 5234               | -                             | 3" (76mm)          | 3½" (89mm)       | 1¾"                | 0.800   | 1.400  | .60   |
|  |                         | 1B44               | 1B44                          | 4" (102mm)         | 4¼" (108mm)      | 1¾"                | 0.898   | 1.822  | .60   |
|  |                         | 1B54               | 1B54                          | 5" (127mm)         | 5¼" (133mm)      | 1¾"                | 1.142   | 2.872  | .60   |
|  |                         | 3B64               | -                             | 6" (152mm)         | 6¼" (159mm)      | 1¾"                | 1.614   | 4.720  | 1.00  |
| 12B  | 75 lb./ft.<br>12' span  | 3B44               | -                             | 4" (102mm)         | 4¼" (108mm)      | 1¾"                | 1.148   | 2.316  | .60   |
|  |                         | 1B54               | 1B54                          | 5" (127mm)         | 5¼" (133mm)      | 1¾"                | 1.142   | 2.872  | .60   |
|  |                         | 3B64               | -                             | 6" (152mm)         | 6¼" (159mm)      | 1¾"                | 1.614   | 4.720  | .60   |
| 12C  | 100 lb./ft.<br>12' span | 5B44               | -                             | 4" (102mm)         | 4¾" (108mm)      | 1¾"                | 1.646   | 3.058  | 1.00  |
|  |                         | 3B54               | -                             | 5" (127mm)         | 5¼" (133mm)      | 1¾"                | 1.522   | 3.734  | 1.00  |
|  |                         | 5B64               | -                             | 6" (152mm)         | 6¼" (159mm)      | 1¾"                | 1.944   | 5.866  | 1.00  |
| 16A  | 50 lb./ft.<br>16' span  | 5B44               | -                             | 4" (102mm)         | 4¼" (108mm)      | 1¾"                | 1.646   | 3.058  | 1.00  |
|  |                         | 7454               | 7454                          | 5" (127mm)         | 5¼" (133mm)      | 1¼"                | 2.396   | 6.292  | 1.50  |
|  |                         | 1D64               | 1D64                          | 6" (152mm)         | 6¼" (159mm)      | 1¼"                | 2.378   | 7.202  | 1.00  |
| 16B  | 75 lb./ft.<br>16' span  | 3D44               | 3D44                          | 4" (102mm)         | 4¼" (108mm)      | 1¼"                | 2.242   | 4.406  | 1.00  |
|  |                         | 7454               | 7454                          | 5" (127mm)         | 5¼" (133mm)      | 1¼"                | 2.396   | 6.292  | 1.50  |
|  |                         | 1D64               | 1D64                          | 6" (152mm)         | 6¼" (159mm)      | 1¼"                | 2.378   | 7.202  | 1.00  |
| 16C  | 100 lb./ft.<br>16' span | 5D44               | 5D44                          | 4" (102mm)         | 4¼" (108mm)      | 1¼"                | 2.782   | 5.738  | 1.50  |
|  |                         | 3D54               | 3D54                          | 5" (127mm)         | 5¼" (133mm)      | 1¼"                | 3.434   | 8.746  | 2.00  |
|  |                         | 7D64               | -                             | 6" (152mm)         | 6¼" (159mm)      | 1¼"                | 4.186   | 12.024   | 2.00  |
| 20A  | 50 lb./ft.<br>20' span  | 3D44               | -                             | 4" (102mm)         | 4¼" (108mm)      | 1¼"                | 2.242   | 4.406  | 1.00  |
|  |                         | 7454               | 7454                          | 5" (127mm)         | 5¼" (133mm)      | 1¼"                | 2.396   | 6.292  | 1.50  |
|  |                         | 1D64               | 1D64                          | 6" (152mm)         | 6¼" (159mm)      | 1¼"                | 2.378   | 7.202  | 1.00  |
| 20B  | 75 lb./ft.<br>20' span  | 3D54               | 3D54                          | 5" (127mm)         | 5¼" (133mm)      | 1¼"                | 3.434   | 8.746  | 2.00  |
|  |                         | 7D64               | 7D64                          | 6" (152mm)         | 6¼" (159mm)      | 1¼"                | 4.186   | 12.024   | 2.00  |
| 20C  | 100 lb./ft.<br>20' span | 5E44               | 5E44                          | 4" (102mm)         | 4¼" (108mm)      | 1½"                | 3.716   | 3.879  | 2.00  |
|  |                         | 5D54               | -                             | 5" (127mm)         | 5¼" (133mm)      | 1¼"                | 3.910   | 10.020   | 2.00  |
|  |                         | 7D64               | 7D64                          | 6" (152mm)         | 6¼" (159mm)      | 1¼"                | 4.186   | 12.024   | 2.00  |
| <b>EXTRA HEAVY DUTY - VERY LONG SPAN TRAYS - SOLID OR VENTILATED BOTTOMS</b> |                         |                    |                               |                    |                  |                    |   |  |   |
|  |                         | 9D64               | -                             | 6" (152mm)         | 6¼" (159mm)      | 1¼"                | 5.130   | 15.700   | 2.00  |
|  |                         | 7G64               | -                             | 6" (152mm)         | 6¼" (159mm)      | 2"                 | 5.804   | 17.456   | 2.00  |

**NOTE:**   indicates most common systems. Consult factory for lead times on other systems.

### LOAD AND DEFLECTION DATA FOR ALUMINUM TROF

Working (Allowable) Load Capacity, Evenly Distributed - Tested per NEMA Standard VE-1

Span (Ft.) - Simple Beam - SAFETY FACTOR: 1.5

| Cope Sys. No. | 6 Ft. Span |     |      | 8 Ft. Span |     |      | 10 Ft. Span |      |      | 12 Ft. Span |      |      | 16 Ft. Span |      |      | 20 Ft. Span |      |      | 24 Ft. Span |      |      | 25 Ft. Span |      |      |  |
|---------------|------------|-----|------|------------|-----|------|-------------|------|------|-------------|------|------|-------------|------|------|-------------|------|------|-------------|------|------|-------------|------|------|--|
|               | w          | d   | k    | w          | d   | k    | w           | d    | k    | w           | d    | k    | w           | d    | k    | w           | d    | k    | w           | d    | k    | w           | d    | k    |  |
| 5234          | 207        | .43 | .002 | 117        | .77 | .007 | 75          | 1.20 | .016 | 52          | 1.73 | .033 |             |      |      |             |      |      |             |      |      |             |      |      |  |
| 1B44          | 222        | .35 | .002 | 125        | .63 | .005 | 80          | .99  | .012 | 55          | 1.42 | .026 |             |      |      |             |      |      |             |      |      |             |      |      |  |
| 1B54          | 324        | .33 | .001 | 182        | .59 | .003 | 117         | .87  | .007 | 77          | 1.26 | .016 |             |      |      |             |      |      |             |      |      |             |      |      |  |
| 3B64          | 359        | .22 | †    | 191        | .37 | .002 | 115         | .55  | .005 | 75          | .74  | .010 |             |      |      |             |      |      |             |      |      |             |      |      |  |
| 3B44          | 354        | .45 | .001 | 191        | .76 | .004 | 117         | 1.14 | .010 | 78          | 1.57 | .020 |             |      |      |             |      |      |             |      |      |             |      |      |  |
| 1B54          | 324        | .33 | .001 | 182        | .59 | .003 | 117         | .87  | .007 | 77          | 1.26 | .016 |             |      |      |             |      |      |             |      |      |             |      |      |  |
| 3B64          | 359        | .22 | †    | 191        | .37 | .002 | 115         | .55  | .005 | 75          | .74  | .010 |             |      |      |             |      |      |             |      |      |             |      |      |  |
| 5B44          | 362        | .32 | †    | 251        | .69 | .003 | 161         | 1.08 | .007 | 112         | 1.55 | .014 |             |      |      |             |      |      |             |      |      |             |      |      |  |
| 3B54          | 394        | .31 | †    | 222        | .55 | .002 | 142         | .86  | .006 | 100         | 1.24 | .012 |             |      |      |             |      |      |             |      |      |             |      |      |  |
| 5B64          | 480        | .24 | †    | 257        | .40 | .002 | 156         | .60  | .04  | 102         | .81  | .008 |             |      |      |             |      |      |             |      |      |             |      |      |  |
| 5B44          |            |     |      | 251        | .69 | .003 | 161         | 1.08 | .007 | 112         | 1.55 | .014 | 51          | 2.26 | .044 | 25          | 2.75 | .110 |             |      |      |             |      |      |  |
| 7454          |            |     |      | 349        | .51 | .001 | 223         | .80  | .004 | 155         | 1.15 | .007 | 79          | 1.85 | .023 | 51          | 2.89 | .057 |             |      |      |             |      |      |  |
| 1D64          |            |     |      | 380        | .49 | .001 | 222         | .69  | .003 | 154         | 1.00 | .006 | 78          | 1.61 | .021 | 50          | 2.51 | .050 |             |      |      |             |      |      |  |
| 3D44          |            |     |      | 342        | .72 | .002 | 219         | 1.12 | .005 | 152         | 1.61 | .011 | 82          | 2.74 | .033 | 52          | 4.27 | .082 |             |      |      |             |      |      |  |
| 7454          |            |     |      | 349        | .51 | .001 | 223         | .80  | .004 | 155         | 1.15 | .007 | 79          | 1.85 | .023 | 51          | 2.89 | .057 |             |      |      |             |      |      |  |
| 1D64          |            |     |      | 380        | .49 | .001 | 222         | .69  | .003 | 154         | 1.00 | .006 | 78          | 1.61 | .021 | 50          | 2.51 | .050 |             |      |      |             |      |      |  |
| 5D44          |            |     |      | 444        | .71 | .002 | 284         | 1.10 | .004 | 188         | 1.53 | .008 | 106         | 2.73 | .026 | 65          | 4.07 | .063 |             |      |      |             |      |      |  |
| 3D54          |            |     |      | 525        | .55 | .001 | 336         | .86  | .003 | 233         | 1.24 | .005 | 119         | 2.01 | .017 | 76          | 3.14 | .041 |             |      |      |             |      |      |  |
| 7D64          |            |     |      |            |     |      | 404         | .76  | .002 | 281         | 1.09 | .004 | 158         | 1.94 | .012 | 101         | 3.02 | .030 |             |      |      |             |      |      |  |
| 3D44          |            |     |      |            |     |      |             |      |      | 152         | 1.61 | .011 | 82          | 2.74 | .033 | 52          | 4.27 | .082 |             |      |      |             |      |      |  |
| 7454          |            |     |      |            |     |      |             |      |      | 155         | 1.15 | .007 | 79          | 1.85 | .023 | 51          | 2.89 | .057 |             |      |      |             |      |      |  |
| 1D64          |            |     |      |            |     |      |             |      |      | 154         | 1.00 | .006 | 78          | 1.61 | .021 | 50          | 2.51 | .050 |             |      |      |             |      |      |  |
| 3D54          |            |     |      |            |     |      |             |      |      | 233         | 1.24 | .005 | 119         | 2.01 | .017 | 76          | 3.14 | .041 |             |      |      |             |      |      |  |
| 7D64          |            |     |      |            |     |      |             |      |      | 281         | 1.09 | .004 | 158         | 1.94 | .012 | 101         | 3.02 | .030 |             |      |      |             |      |      |  |
| 5E44          |            |     |      |            |     |      |             |      |      | 298         | 1.79 | .006 | 161         | 3.07 | .019 | 103         | 4.79 | .047 |             |      |      |             |      |      |  |
| 5D54          |            |     |      |            |     |      |             |      |      | 290         | 1.35 | .005 | 156         | 2.30 | .015 | 100         | 3.59 | .036 |             |      |      |             |      |      |  |
| 7D64          |            |     |      |            |     |      |             |      |      | 281         | 1.09 | .004 | 158         | 1.94 | .012 | 101         | 3.02 | .030 |             |      |      |             |      |      |  |
| 9D64          |            |     |      |            |     |      |             |      |      | 412         | 1.22 | .003 | 214         | 2.00 | .009 | 131         | 3.01 | .023 | 68          | 3.23 | .048 |             |      |      |  |
| 7G64          |            |     |      |            |     |      |             |      |      | 451         | 1.20 | .003 | 253         | 2.14 | .008 | 162         | 3.35 | .020 | 112         | 4.79 | .043 | 104         | 5.24 | .050 |  |

**Note:** To convert 1.5 safety factor to 2.0 multiply w, d, k by .75

w=Pounds per linear foot

Metric: for kg/m multiply w by 1.48

d=Deflection (inches)

k=Deflection (in.) for each pound of load

†=Denotes k is less than .001 inch

# TROF CABLE TRAY SYSTEM



## SELECTION CHART:

### Steel Tray

#### NEMA CLASS, PHYSICAL AND STRUCTURAL PROPERTIES

| NEMA Standard VE-1 Load/Span Class   | NEMA Load/Span       | Mill Galv. System No. | HDGAF System No. | Type 304 SS System No. | Cope HDGAF Systems Certified by CSA | Nominal Load Depth | Side Rail Height | Flange Width (in.) | Section Modulus of 2 Rails Sx (in. <sup>3</sup> ) | Moment of Inertia for 2 Rails Ix (in. <sup>4</sup> ) | Minimum X-Sect. Area of 2 Rails per NEC 392.7 (in. <sup>2</sup> ) |
|--|----------------------|-----------------------|------------------|------------------------|-------------------------------------|--------------------|------------------|--------------------|---|--|---|
| 8A - 12A   | 50 lb./ft. 12' span  | 8232                  | 6233             | 823U                   | -                                   | 3" (76mm)          | 3 1/2" (89mm)    | 13/16"             | 0.444   | 1.378  | .40   |
|  |                      | 8242                  | 6243             | 824U                   | 8242/3                              | 4" (102mm)         | 4 1/4" (108mm)   | 13/16"             | 0.592   | 1.258  | .40   |
|  |                      | 8252                  | 6253             | 825U                   | -                                   | 5" (127mm)         | 5 1/4" (133mm)   | 13/16"             | 0.816   | 2.142  | .40   |
|  |                      | 8262                  | 6263             | 826U                   | 8262/3                              | 6" (152mm)         | 6 1/4" (159mm)   | 13/16"             | 1.072   | 3.352  | .70   |
| 12B  | 75 lb./ft. 12' span  | 4232                  | 4233             | 423U                   | -                                   | 3" (76mm)          | 3 1/2" (89mm)    | 13/16"             | 0.674   | 1.180  | .70   |
|  |                      | 8B42                  | 6B43             | 8B4U                   | -                                   | 4" (102mm)         | 4 1/4" (108mm)   | 13/16"             | 0.678   | 1.370  | .40   |
|  |                      | 8252                  | 6253             | 825U                   | -                                   | 5" (127mm)         | 5 1/4" (133mm)   | 13/16"             | 0.816   | 2.142  | .40   |
|  |                      | 8262                  | 6263             | 826U                   | 8262/3                              | 6" (152mm)         | 6 1/4" (159mm)   | 13/16"             | 1.072   | 3.352  | .70   |
| 12C  | 100 lb./ft. 12' span | 6B42                  | 6B43             | 6B4U                   | -                                   | 4" (102mm)         | 4 1/4" (108mm)   | 13/16"             | 0.834   | 1.690  | .70   |
|  |                      | 6B52                  | 6B53             | 6B5U                   | -                                   | 5" (127mm)         | 5 1/4" (133mm)   | 13/16"             | 1.140   | 2.872  | .70   |
|  |                      | 6262                  | 6263             | 626U                   | -                                   | 6" (152mm)         | 6 1/4" (159mm)   | 13/16"             | 1.330   | 4.158  | .70   |
| 16A  | 50 lb./ft. 16' span  | 8D42                  | 6D43             | 8D4U                   | -                                   | 4" (102mm)         | 4 1/4" (108mm)   | 1 1/4"             | 0.852   | 1.736  | .40   |
|  |                      | 6452                  | 6453             | 645U                   | 6452/3                              | 5" (127mm)         | 5 1/4" (133mm)   | 1 1/4"             | 1.280   | 3.360  | .70   |
|  |                      | 6462                  | 6463             | 646U                   | 6462/3                              | 6" (152mm)         | 6 1/4" (159mm)   | 1 1/4"             | 1.652   | 5.160  | .70   |
| 16B  | 75 lb./ft. 16' span  | 6D42                  | 6D43             | 6D4U                   | -                                   | 4" (102mm)         | 4 1/4" (108mm)   | 1 1/4"             | 1.056   | 2.152  | .70   |
|  |                      | 6452                  | 6453             | 645U                   | 6452/3                              | 5" (127mm)         | 5 1/4" (133mm)   | 1 1/4"             | 1.280   | 3.360  | .70   |
|  |                      | 6462                  | 6463             | 646U                   | 6462/3                              | 6" (152mm)         | 6 1/4" (159mm)   | 1 1/4"             | 1.652   | 5.160  | .70   |
| 16C  | 100 lb./ft. 16' span | 4D42                  | 4D43             | 4D4U                   | -                                   | 4" (102mm)         | 4 1/4" (108mm)   | 1 1/4"             | 1.298   | 2.652  | 1.00  |
|  |                      | 6452                  | 6453             | 645U                   | 6452/3                              | 5" (127mm)         | 5 1/4" (133mm)   | 1 1/4"             | 1.280   | 3.360  | .70   |
|  |                      | 6462                  | 6463             | 646U                   | 6462/3                              | 6" (152mm)         | 6 1/4" (159mm)   | 1 1/4"             | 1.652   | 5.160  | .70   |
| 20A  | 50 lb./ft. 20' span  | 6D42                  | 6D43             | 6D4U                   | -                                   | 4" (102mm)         | 4 1/4" (108mm)   | 1 1/4"             | 1.056   | 2.152  | .70   |
|  |                      | 6452                  | 6453             | 645U                   | 6452/3                              | 5" (127mm)         | 5 1/4" (133mm)   | 1 1/4"             | 1.280   | 3.360  | .70   |
|  |                      | 6462                  | 6463             | 646U                   | 6462/3                              | 6" (152mm)         | 6 1/4" (159mm)   | 1 1/4"             | 1.652   | 5.160  | 1.00  |
| 20B  | 75 lb./ft. 20' span  | 2D42                  | 2D43             | 2D4U                   | -                                   | 4" (102mm)         | 4 1/4" (108mm)   | 1 1/4"             | 1.758   | 3.604  | 1.00  |
|  |                      | 4D52                  | 4D53             | 4D5U                   | 4D52/3                              | 5" (127mm)         | 5 1/4" (133mm)   | 1 1/4"             | 1.744   | 4.418  | 1.00  |
|  |                      | 6D62                  | 6D63             | 6D6U                   | -                                   | 6" (152mm)         | 6 1/4" (159mm)   | 1 1/4"             | 1.814   | 5.486  | 1.00  |
| 20C  | 100 lb./ft. 20' span | 2D52                  | 2D53             | 2D5U                   | -                                   | 5" (127mm)         | 5 1/4" (133mm)   | 1 1/4"             | 2.370   | 6.026  | 1.50  |
|  |                      | 4D62                  | 4D63             | 4D6U                   | 4D62/3                              | 6" (152mm)         | 6 1/4" (159mm)   | 1 1/4"             | 2.240   | 6.778  | 1.00  |
| <b>EXTRA HEAVY DUTY - VERY LONG SPAN TRAYS - SOLID OR VENTILATED BOTTOMS</b> |                      |                       |                  |                        |                                     |                    |                  |                    |   |  |   |
|  |                      | 2D62                  | 2D63             | 2D6U                   | -                                   | 6" (152mm)         | 6 1/4" (159mm)   | 1 1/4"             | 3.056   | 9.270  | 1.50  |
|  |                      | 11D62                 | 11D63            | 11D6U                  | -                                   | 6" (152mm)         | 6 1/4" (159mm)   | 1 1/4"             | 3.536   | 10.630   | 1.50  |

Note:   indicates most common systems. Consult factory for lead times on other systems.

**LOAD AND DEFLECTION DATA FOR STEEL TROF**  
**Working (Allowable) Load Capacity, Evenly Distributed-Tested per NEMA Standard VE-1**  
**Span (ft.) - Simple Beam - SAFETY FACTOR: 1.5**

| Cope<br>Sys. No. | 6 Ft. Span |     |      | 8 Ft. Span |     |      | 10 Ft. Span |     |      | 12 Ft. Span |      |      | 16 Ft. Span |      |      | 20 Ft. Span |      |      | 24 Ft. Spa |      |      | 25 Ft. Span |      |      |
|------------------|------------|-----|------|------------|-----|------|-------------|-----|------|-------------|------|------|-------------|------|------|-------------|------|------|------------|------|------|-------------|------|------|
|                  | w          | d   | k    | w          | d   | k    | w           | d   | k    | w           | d    | k    | w           | d    | k    | w           | d    | k    | w          | d    | k    | w           | d    | k    |
| 8232/3/U         | 230        | .30 | .001 | 126        | .52 | .004 | 79          | .79 | .010 | 53          | 1.11 | .021 |             |      |      |             |      |      |            |      |      |             |      |      |
| 8242/3/U         | 292        | .23 | †    | 164        | .42 | .003 | 103         | .63 | .006 | 69          | .89  | .013 |             |      |      |             |      |      |            |      |      |             |      |      |
| 8252/3/U         | 383        | .18 | †    | 210        | .31 | .001 | 127         | .46 | .004 | 83          | .62  | .007 |             |      |      |             |      |      |            |      |      |             |      |      |
| 8262/3/U         | 357        | .11 | †    | 194        | .18 | †    | 119         | .28 | .002 | 79          | .38  | .005 |             |      |      |             |      |      |            |      |      |             |      |      |
| 4232/3/U         | 358        | .30 | †    | 197        | .53 | .003 | 124         | .81 | .007 | 83          | 1.13 | .014 |             |      |      |             |      |      |            |      |      |             |      |      |
| 8B42/3/U         | 360        | .26 | †    | 198        | .46 | .002 | 124         | .70 | .006 | 84          | .98  | .012 |             |      |      |             |      |      |            |      |      |             |      |      |
| 8252/3/U         | 383        | .18 | †    | 210        | .31 | .001 | 127         | .46 | .004 | 83          | .62  | .007 |             |      |      |             |      |      |            |      |      |             |      |      |
| 8262/3/U         | 357        | .11 | †    | 194        | .18 | †    | 119         | .28 | .002 | 79          | .38  | .005 |             |      |      |             |      |      |            |      |      |             |      |      |
| 6B42/3/U         | 453        | .27 | †    | 249        | .47 | .002 | 156         | .71 | .005 | 106         | 1.00 | .009 |             |      |      |             |      |      |            |      |      |             |      |      |
| 6B52/3/U         | 591        | .21 | †    | 325        | .36 | .001 | 203         | .55 | .003 | 137         | .77  | .006 |             |      |      |             |      |      |            |      |      |             |      |      |
| 6262/3/U         | 460        | .11 | †    | 250        | .19 | †    | 154         | .29 | .002 | 103         | .40  | .004 |             |      |      |             |      |      |            |      |      |             |      |      |
| 8D42/3/U         |            |     |      | 290        | .53 | .002 | 182         | .81 | .004 | 126         | 1.17 | .009 | 65          | 1.91 | .029 |             |      |      |            |      |      |             |      |      |
| 6452/3/U         |            |     |      | 444        | .42 | †    | 273         | .63 | .002 | 186         | .89  | .005 | 100         | 1.51 | .015 |             |      |      |            |      |      |             |      |      |
| 6462/3/U         |            |     |      | 574        | .42 | †    | 367         | .55 | .001 | 245         | .76  | .003 | 123         | 1.22 | .010 |             |      |      |            |      |      |             |      |      |
| 6D42/3/U         |            |     |      | 381        | .56 | .001 | 244         | .88 | .004 | 169         | 1.27 | .008 | 88          | 2.08 | .024 |             |      |      |            |      |      |             |      |      |
| 6452/3/U         |            |     |      | 444        | .42 | †    | 273         | .63 | .002 | 186         | .89  | .005 | 100         | 1.51 | .015 |             |      |      |            |      |      |             |      |      |
| 6462/3/U         |            |     |      | 574        | .42 | †    | 367         | .55 | .001 | 245         | .76  | .003 | 123         | 1.22 | .010 |             |      |      |            |      |      |             |      |      |
| 4D42/3/U         |            |     |      | 487        | .58 | .001 | 312         | .91 | .003 | 216         | 1.31 | .006 | 113         | 2.16 | .019 |             |      |      |            |      |      |             |      |      |
| 6452/3/U         |            |     |      | 444        | .42 | †    | 273         | .63 | .002 | 186         | .89  | .005 | 100         | 1.51 | .015 |             |      |      |            |      |      |             |      |      |
| 6462/3/U         |            |     |      | 574        | .42 | †    | 367         | .55 | .001 | 245         | .76  | .003 | 123         | 1.22 | .010 |             |      |      |            |      |      |             |      |      |
| 6D42/3/U         |            |     |      |            |     |      |             |     |      | 169         | 1.27 | .008 | 88          | 2.08 | .024 | 52          | 2.98 | .057 |            |      |      |             |      |      |
| 6452/3/U         |            |     |      |            |     |      |             |     |      | 186         | .89  | .005 | 100         | 1.51 | .015 | 53          | 1.94 | .037 |            |      |      |             |      |      |
| 6462/3/U         |            |     |      |            |     |      |             |     |      | 245         | .76  | .003 | 123         | 1.22 | .010 | 66          | 1.59 | .024 |            |      |      |             |      |      |
| 2D42/3/U         |            |     |      |            |     |      |             |     |      | 304         | 1.36 | .004 | 159         | 2.24 | .014 | 94          | 3.23 | .034 |            |      |      |             |      |      |
| 4D52/3/U         |            |     |      |            |     |      |             |     |      | 280         | 1.02 | .004 | 145         | 1.67 | .012 | 85          | 2.40 | .028 |            |      |      |             |      |      |
| 6D62/3/U         |            |     |      |            |     |      |             |     |      | 269         | .80  | .003 | 139         | 1.28 | .009 | 81          | 1.82 | .022 |            |      |      |             |      |      |
| 2D52/3/U         |            |     |      |            |     |      |             |     |      | 395         | 1.05 | .003 | 206         | 1.74 | .008 | 121         | 2.50 | .021 |            |      |      |             |      |      |
| 4D62/3/U         |            |     |      |            |     |      |             |     |      | 296         | .79  | .003 | 152         | 1.28 | .008 | 105         | 1.91 | .018 |            |      |      |             |      |      |
| 2D62/3/U         |            |     |      |            |     |      |             |     |      | 390         | .85  | .002 | 221         | 1.40 | .006 | 149         | 2.00 | .013 | 79         | 1.91 | .024 | 73          | 2.38 | .033 |
| 11D62/3/U        |            |     |      |            |     |      |             |     |      | 434         | .66  | †    | 244         | 1.17 | .005 | 156         | 1.82 | .012 | 108        | 2.62 | .024 | 100         | 2.85 | .029 |

*NOTE:* To convert 1.5 safety factor to 2.0 multiply w, d, k by .75

w = Pounds per linear foot

Metric: for kg/m multiply by 1.48

d = Deflection (inches)

k = Deflection (in.) for each pound of load

† = Denotes k is less than .001 inch

## OVERVIEW

**AB-COPE TROF** is a prefabricated metal structure consisting of ventilated or solid bottoms, welded to the side rails, and are manufactured and tested to NEMA Standard VE-1. Straight sections, fittings (elbows, tees, crosses, reducers, a full line of matching and interfacing accessories are available. Corrugations give great lateral rigidity to the bottom transmitting the load to the side rails. Lateral (transverse) deflection is nearly eliminated compared to rung type trofs where the rails are not continuously braced by the bottom. AB-Cope Corrugated bottoms do NOT limit the tray load capacity.

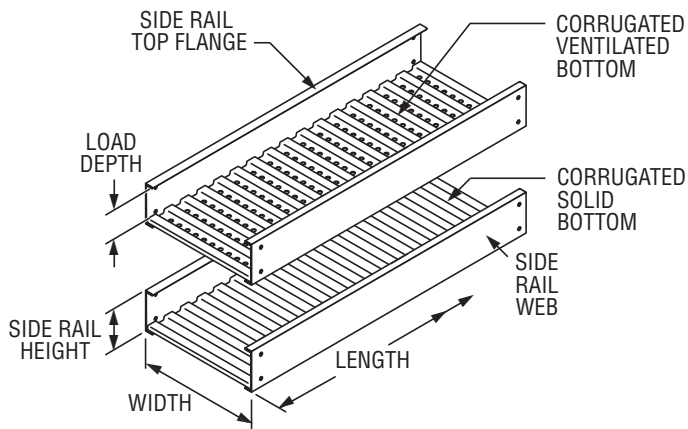

**STRAIGHT SECTION**

Corrugated bottoms have 1" wide ribs on 2" centers. Ventilation holes in the valleys of the corrugations are 1 1/16" diameter on one inch (1") centers. Free passage of air through the openings results in a 68% open area at the elevated cable support surface on top of ribs.

Solid Trof have the same corrugations but have no holes.

**Note:** Where drain holes are required, one can be placed in the center of each valley, if specified.

## AB-COPE TROF WITH THREE IMPORTANT INDUSTRY-LEADING FEATURES:

### 1. New Universal Curvilinear Splice Plate System

The splice plates for rigid connections have a slight curve so they can be used on straight sections or fittings. Tightening of the fastener pulls the plate flush with the side rail. The fasteners are snug and the joint is structurally and electrically superior. Even when hand-tightened, there is pressure on the fastener to hold it securely.

*Note: Heavy Duty, Mid Span Splice Plates available upon request.*

### 2. Zero Tangent Fittings

Tangent as referred to on cable tray fittings is the straight at the end of the curve to accommodate a flat splice plate. This wastes space in tightly packed areas, such as spreader rooms, where the heat of thousands of cables accumulate. Eliminating tangents allow more tray runs to distribute the heat. AB-COPE ZERO TANGENT FITTINGS CAN SAVE UP TO 12" PER ROW OF TRAY.

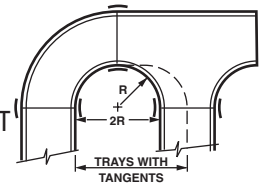

**BONUS:** Inspection for proper installation of splice plate is visual. If the plate is bowed away from the rail, nuts must be tightened.

### 3. The Exclusive Auto Arc-Welded Assembly System

Corrugated bottoms on straight sections are assembled to the side rails using an automatic, self indexing MIG-arc-welding system fusing a 1/2" diameter zone. These welds are 700% larger and stronger than the common resistance (spot) weld in use today. Electrical properties of the assembly are unequalled; are well within the NEMA requirements due to the continuous electrical path. The mechanical strength of this welded assembly withstands the rigors of shipping, handling, installation and service. The size of the weld keeps the vertical axis of the side rail from sloping inward under load. The weld maintains the 90° angle between the side rail and bottom. This allows full use of the section properties. Spot welds do not permit this. Also, stresses on spot welds (barely 1/8" in diameter) are so severe that breakage often occurs during shipping and installation. AB-Cope Trof fittings are also assembled by MIG-arc-welding.

### USES OF AB-COPE TROF

Generally, AB-Cope Trof is optimum for ANY size cable. It offers continuous support with or without ventilation. The bottom design offers safety and security from unauthorized personnel. The vent holes may be bushed with a grommet for dropping out communication cables (Cat. DOG-2).

## PART NUMBERING SYSTEM:

Please pay careful attention to the part numbering structure. Example: Catalog No. 1B44-06SL-12-V is a 4 inch load depth aluminum ladder with 1<sup>3</sup>/<sub>16</sub>" flange, 6 inches wide, straight length 12 feet long, with ventilated bottom. Please make sure you use the system numbers from pages 137 through 140.

### Straight Length

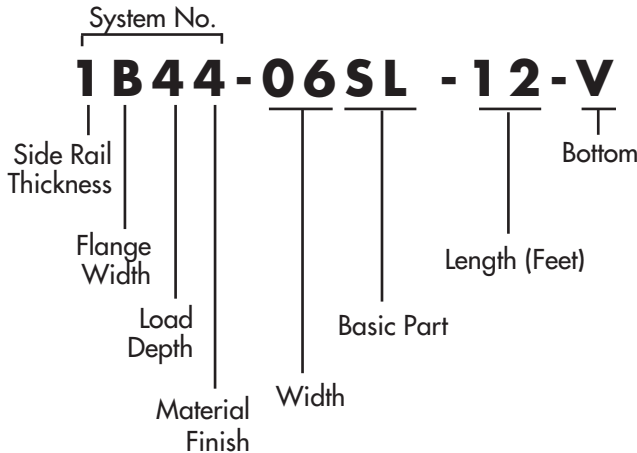

### Fittings

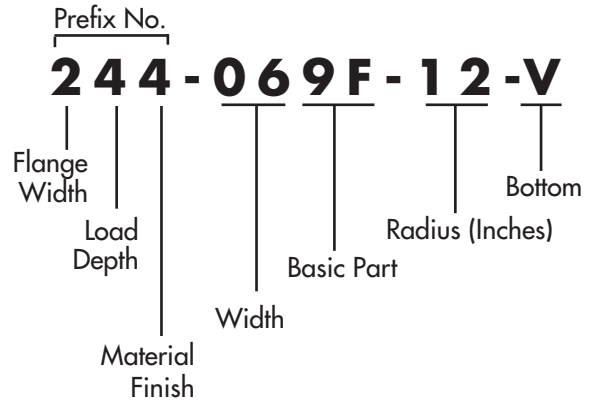

### SYSTEM NUMBER (STRAIGHT SECTION ONLY)

– The first four digits make up the system number which identifies the structural, dimensional, and material characteristics of the straight length. It is made up of the side rail digits indicating the side rail thickness and flange width, the load depth (inside, in inches), and material finish (galvanized, aluminum or coated).

**PREFIX NUMBER (FITTINGS ONLY)** – Fittings are ordered using the 3-digit prefix number given in the charts on the fitting pages. Fittings do not have stiffened upper flanges.

**WIDTH** – Identifies the inside width of the tray in inches.

**BASIC PART NUMBER** – Identifies the straight length, fitting, or accessory.

**SECONDARY DIMENSION NUMBER** – Identifies the length of a straight section in feet, the radius of a fitting in inches, or the second width of a reducer in inches.

**BOTTOM TYPE**– Identifies the type bottom: V (Ventilated) or S (Solid). Example: 1B44-06SL-12-V is a 4" load depth aluminum Trof with a 1<sup>3</sup>/<sub>16</sub>" flange, 6" wide, straight length 12' long with a ventilated bottom.

| Thickness Steel (Ga.) | Flange Width                                | Load Depth | Material Finish |
|-----------------------|---|------------|-----------------|
| 8 - 18 ga.            | 2 - 1 <sup>3</sup> / <sub>16</sub> " (21mm) | 3" (76mm)  | 2 - Mill-Galv.  |
| 6 - 16 ga.            | 4 - 1 <sup>1</sup> / <sub>4</sub> " (32mm)  | 4" (102mm) | 3 - HDGAF       |
| 4 - 14 ga.            | 5 - 1 <sup>1</sup> / <sub>2</sub> " (38mm)  | 5" (127mm) | 4 - Aluminum    |
| 2 - 12 ga.            | 7 - 2" (51mm)                               | 6" (152mm) | U - 304SS       |
| 11 - 11 ga.           |   |            |                 |

| Thickness Alum (in.) | Flange Width                                | Load Depth | Material Finish |
|----------------------|---|------------|-----------------|
| 1 - Thinner          | B - 1 <sup>3</sup> / <sub>16</sub> " (21mm) |            |                 |
| 3 -                  | D - 1 <sup>1</sup> / <sub>4</sub> " (32mm)  |            |                 |
| 5 - ** ↓             | E - 1 <sup>1</sup> / <sub>2</sub> " (38mm)  |            |                 |
| 7 -                  | G - 2" (51mm)                               |            |                 |
| 9 - Thicker          |   |            |                 |

\*\*Alum. extruded side rails are individually engineered to loads and spans.

| Width (in.)    | Basic Part Number              | Length          | Bottom          |
|----------------|--------------------------------|-----------------|-----------------|
| 06=6" (152mm)  | SL (Straight Len.)             | - 12' (3.7m)    | -V (ventilated) |
| 09=9" (229mm)  | 9F (90° Horiz. El.)            | - 24' (7.3m)    | -S (solid)      |
| 12=12" (305mm) | 6F (60° Horiz. El.)            | - 10' (3m, CSA) |                 |
| 18=18" (457mm) | 4F (45° Horiz. El.)            | - 20' (6m, CSA) |                 |
| 24=24" (610mm) | 3F (30° Horiz. El.)            |                 |                 |
| 30=30" (762mm) | 90 (90° Out. Vert. El.)        |                 |                 |
| 36=36" (914mm) | 60 (60° Out. Vert. El.)        |                 |                 |
|                | 40 (45° Out. Vert. El.)        |                 |                 |
|                | 30 (30° Out. Vert. El.)        |                 |                 |
|                | 9I (90° In. Vert. El.)         |                 |                 |
|                | 6I (60° In. Vert. El.)         |                 |                 |
|                | 4I (45° In. Vert. El.)         |                 |                 |
|                | 3I (30° In. Vert. El.)         |                 |                 |
|                | FT (Horiz. Tee)                |                 |                 |
|                | FC (Horiz. Cross)              |                 |                 |
|                | VT (Vert. Tee)                 |                 |                 |
|                | SR (Vert. Cable Support Elbow) |                 |                 |
|                | ST (Straight Reducer)          |                 |                 |
|                | RH (Right Hand Reducer)        |                 |                 |
|                | LH (Left Hand Reducer)         |                 |                 |
|                | AF (Adjustable Elbow)          |                 |                 |
|                | RY & LY (45° "Y" Branch)       |                 |                 |

| Radius (in.)   |
|----------------|
| 12=12" (305mm) |
| 24=24" (610mm) |
| 36=36" (914mm) |

# TROF CABLE TRAY SYSTEM

## CSA ORDERING INFORMATION

### AB-Cope CSA Standards C22-2 Cable Trof Ventilated & Solid Bottom Type

#### HOW TO ORDER:

Explanation of AB-Cope's Canadian Standards cable tray catalog numbers is described below. Use the system numbers given in selection charts for straight sections, or the fitting prefix numbers given in fitting tables. Be sure to follow system number or the fitting prefix with the item "description" number. The list below gives the CSA compliance items carrying the CSA compliance label

#### Straight Length

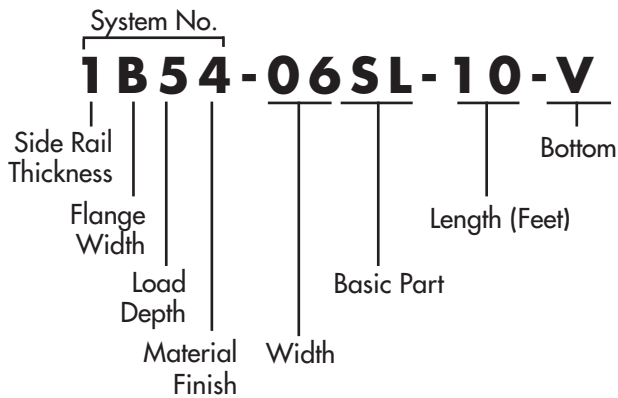

#### Fittings

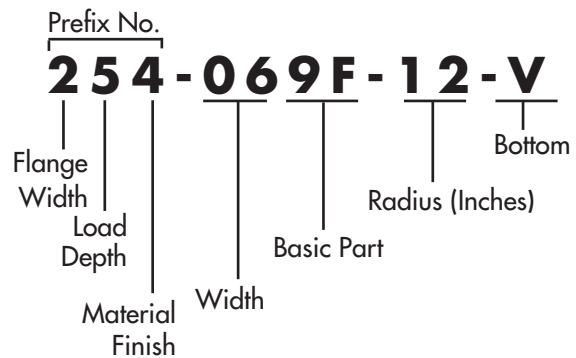

**SYSTEM NUMBER (STRAIGHT SECTION ONLY) –** The first four digits make up the system number which identifies the structural, dimensional, and material characteristics of the straight length. It is made up of the side rail digits indicating the side rail thickness and flange width, the load depth (inside, in inches), and material finish (galvanized, aluminum or coated).

**PREFIX NUMBER (FITTINGS ONLY) –** Fittings are ordered using the 3-digit prefix number given in the charts on the fitting pages. Fittings do not have stiffened upper flanges.

**WIDTH –** Identifies the inside width of the tray (in inches).

**BASIC PART NUMBER –** Identifies the straight length, fitting, or accessory.

**SECONDARY DIMENSION NUMBER –** Identifies the length of a straight section (in feet), the radius of a fitting (in inches), or the second width of a reducer (in inches).

**BOTTOM TYPE –** Identifies the type bottom: V (Ventilated) or S (Solid)

| System Number          |  |            |                           |
|------------------------|--|------------|---------------------------|
| Thickness Steel (Ga.)  | Flange Width                                 | Load Depth | Material Finish           |
| 8 - 18 ga.             | 2 - 1 <sup>3</sup> / <sub>16</sub> " (21mm)  | 4" (102mm) | 3 - HDGAF, CSA Class 1    |
| 6 - 16 ga.             | 4 - 1 <sup>1</sup> / <sub>4</sub> " (32mm)   | 5" (127mm) | 4 - Aluminum Plain Finish |
| 4 - 14 ga.             |  | 6" (152mm) |                           |
| Thickness Alum (in.)** |  |            |                           |
| 1 - thinner            | *B - 1 <sup>3</sup> / <sub>16</sub> " (21mm) |            |                           |
| 3 -                    | *D - 1 <sup>1</sup> / <sub>4</sub> " (32mm)  |            |                           |
| 5 - ** ↓               | *E - 1 <sup>1</sup> / <sub>2</sub> " (38mm)  |            |                           |
| 7 -                    |  |            |                           |
| 9 - thicker            |  |            |                           |

\*Stiffened Upper Flange

\*\*Alum. extruded side rails are individually engineered to loads and spans.

| Description    |                                |               |                 |
|----------------|--------------------------------|---------------|-----------------|
| Width (in.)    | Basic Part No.                 | Length        | Bottom          |
| 06=6" (152mm)  | SL (Straight Length)           | 10 - 10' (3m) | -V (ventilated) |
| 09=9" (229mm)  | 9F (90° Horiz. Elbow)          | 20 - 20' (6m) | -S (solid)      |
| 12=12" (305mm) | 6F (60° Horiz. Elbow)          |               |                 |
| 18=18" (457mm) | 4F (45° Horiz. Elbow)          |               |                 |
| 24=24" (610mm) | 3F (30° Horiz. Elbow)          |               |                 |
| 30=30" (762mm) | 90 (90° Out. Vert. Elbow)      |               |                 |
| 36=36" (914mm) | 60 (60° Out. Vert. Elbow)      |               |                 |
|                | 40 (45° Out. Vert. Elbow)      |               |                 |
|                | 30 (30° Out. Vert. Elbow)      |               |                 |
|                | 9I (90° In. Vert. Elbow)       |               |                 |
|                | 6I (60° In. Vert. Elbow)       |               |                 |
|                | 4I (45° In. Vert. Elbow)       |               |                 |
|                | 3I (30° In. Vert. Elbow)       |               |                 |
|                | FT (Horiz. Tee)                |               |                 |
|                | FC (Horiz. Cross)              |               |                 |
|                | VT (Vert. Tee)                 |               |                 |
|                | SR (Vert. Cable Support Elbow) |               |                 |
|                | ST (Straight Reducer)          |               |                 |
|                | RH (Right Hand Reducer)        |               |                 |
|                | LH (Left Hand Reducer)         |               |                 |
|                | AF (Adjustable Elbow)          |               |                 |
|                | RY & LY (45° "Y" Branch)       |               |                 |
|                |                                |               | Radius (in.)    |
|                |                                |               | 12=12" (305mm)  |
|                |                                |               | 24=24" (610mm)  |
|                |                                |               | 36=36" (914mm)  |

### AB-COPE Systems That Meet Performance Class CSA Std. C22.2

| CSA Class   | Cope System | Load Depth    | Side Rail      | Flange Width   | Max. Load Kg/m (lb/ft) | Maximum Support Span | Deflection at Max Support Span | Meets CSA Elec. Tests |
|---|-------------|---------------|----------------|----------------|------------------------|----------------------|--------------------------------|-----------------------|
| <b>ALUMINUM TROF TRAY - Safety Factor: 1.5</b>    |             |               |                |                |                        |                      |                                |                       |
| C   | <b>1B44</b> | 4" (102mm)    | 4 1/4" (108mm) | 1 3/16" (21mm) | 97 (65)                | 3m                   | 25.1mm                         | Yes                   |
| 20A   | <b>3D44</b> | 4" (102mm)    | 4 1/4" (108mm) | 1 1/4" (32mm)  | 74 (50)                | 6m (1)               | 108.5mm                        | Yes                   |
| 16C   | <b>5D44</b> | 4" (102mm)    | 4 1/4" (108mm) | 1 1/4" (32mm)  | 149 (100)              | 4.9m                 | 71.4mm                         | Yes                   |
| 20C   | <b>5E44</b> | 4" (102mm)    | 4 1/4" (108mm) | 1 1/2" (38mm)  | 149 (100)              | 6m (1)               | 121.7mm                        | Yes                   |
| C   | <b>1B54</b> | 5" (127mm)    | 5 1/4" (133mm) | 1 3/16" (21mm) | 97 (65)                | 3m                   | 22.1mm                         | Yes                   |
| 20A   | <b>7454</b> | 5" (127mm)    | 5 1/4" (133mm) | 1 1/4" (32mm)  | 74 (50)                | 6m (1)               | 73.4mm                         | Yes                   |
| 20B   | <b>3D54</b> | 5" (127mm)    | 5 1/4" (133mm) | 1 1/4" (32mm)  | 112 (75)               | 6m (1)               | 78.7mm                         | Yes                   |
| 20A   | <b>1D64</b> | 6" (152mm)    | 6 1/4" (159mm) | 1 1/4" (32mm)  | 74 (50)                | 6m (1)               | 63.8mm                         | Yes                   |
| 20C   | <b>7D64</b> | 6" (152mm)    | 6 1/4" (159mm) | 1 1/4" (32mm)  | 149 (100)              | 6m (1)               | 76.7mm                         | Yes                   |
| <b>Mil Gal STEEL TROF TRAY Safety Factor: 1.5</b> |             |               |                |                |                        |                      |                                |                       |
| C   | <b>8242</b> | 3 3/4" (95mm) | 4 1/4" (108mm) | 1 3/16" (21mm) | 97 (65)                | 3m                   | 16.0mm                         | Yes                   |
| 20A   | <b>6452</b> | 5" (127mm)    | 5 1/4" (133mm) | 1 1/4" (32mm)  | 74 (50)                | 6m (1)               | 49.3mm                         | Yes                   |
| 20B   | <b>4D52</b> | 5" (127mm)    | 5 1/4" (133mm) | 1 1/4" (32mm)  | 112 (75)               | 6m (1)               | 61.0mm                         | Yes                   |
| 12B   | <b>8262</b> | 6" (152mm)    | 6 1/4" (159mm) | 1 3/16" (21mm) | 112 (75)               | 3.7m                 | 9.7mm                          | Yes                   |
| 20A   | <b>6462</b> | 6" (152mm)    | 6 1/4" (159mm) | 1 1/4" (32mm)  | 74 (50)                | 6m (1)               | 40.4mm                         | Yes                   |
| 20C   | <b>4D62</b> | 6" (152mm)    | 6 1/4" (159mm) | 1 1/4" (32mm)  | 149 (100)              | 6m                   | 48.5mm                         | Yes                   |
| <b>HDGAF STEEL TROF TRAY Safety Factor: 1.5</b>   |             |               |                |                |                        |                      |                                |                       |
| C   | <b>8243</b> | 3 3/4" (95mm) | 4 1/4" (108mm) | 1 3/16" (21mm) | 97 (65)                | 3m                   | 16.0mm                         | Yes                   |
| 20A   | <b>6453</b> | 5" (127mm)    | 5 1/4" (133mm) | 1 1/4" (32mm)  | 74 (50)                | 6m (1)               | 49.3mm                         | Yes                   |
| 20B   | <b>4D53</b> | 5" (127mm)    | 5 1/4" (133mm) | 1 1/4" (32mm)  | 112 (75)               | 6m (1)               | 61.0mm                         | Yes                   |
| 12B   | <b>8263</b> | 6" (152mm)    | 6 1/4" (159mm) | 1 3/16" (21mm) | 112 (75)               | 3.7m                 | 9.7mm                          | Yes                   |
| 20A   | <b>6463</b> | 6" (152mm)    | 6 1/4" (159mm) | 1 1/4" (32mm)  | 74 (50)                | 6m (1)               | 40.4mm                         | Yes                   |
| 20C   | <b>4D63</b> | 6" (152mm)    | 6 1/4" (159mm) | 1 1/4" (32mm)  | 149 (100)              | 6m                   | 48.5mm                         | Yes                   |

Notes: (1) Also recommended for 3 meter support spans

**Note:**   indicates most common systems. Consult factory for lead times on other systems.

### CSA LOADS

Identify the desired load designation needed for your project from the chart below. Both CSA Class and NEMA designations are listed by load capability and span. Then, select the CSA Compliance AB-Cope System from the table above. Where CSA C22.2 is not mandatory, you may want to consider one of the other AB-Cope systems offered on the selection charts (page 143 thru 144).

| Load, kg/m (lb/ft) | Historical Load/Span Class Designation |          |          |          |          |
|--------------------|--|----------|----------|----------|----------|
|                    | Span, m (ft)                           |          |          |          |          |
|                    | 2.4 (8)                                | 3.0 (10) | 3.7 (12) | 4.9 (16) | 6.0 (20) |
| 37 (25)            | –                                      | A        | –        | –        | –        |
| 67 (45)            | –                                      | –        | –        | –        | D        |
| 74 (50)            | 8A                                     | –        | 12A      | 16A      | 20A      |
| 97 (65)            | –                                      | C        | –        | –        | –        |
| 112 (75)           | 8B                                     | –        | 12B      | 16B      | E or 20B |
| 149 (100)          | 8C                                     | –        | 12C      | 16C      | 20C      |
| 179 (120)          | –                                      | D        | –        | –        | –        |
| 299 (200)          | –                                      | E        | –        | –        | –        |

**Note:** 8A/B/C, 12A/B/C, 16A/B/C, and 20A/B/C have been NEMA designations.

A, B, C, D and E have been CSA designations

### RECEIVING, INSTALLING, AND MAINTENANCE

The proper care and handling of cable Trofs by the receiver and installers is very important to insure a safe installation that will meet the intended service life. AB-Cope has an installation guide available to assist the installers and those who will maintain the installed system

### DIMENSIONS AND STRUCTURAL PROPERTIES: COPE CSA SYSTEMS

The performance of the AB-Cope cable Trof systems compliance by CSA is given above. Structural properties of straight sections, though not required to be listed, are given in the AB-Cope NEMA selection charts, in English units. Dimensions of straight sections and certified fittings are furnished in English and metric units for use in layout and/or entry into computerized systems.

**NOTE:** For other CSA compliance systems please contact the factory.

# TROF CABLE TRAY SYSTEM

## Straight Length [SL]

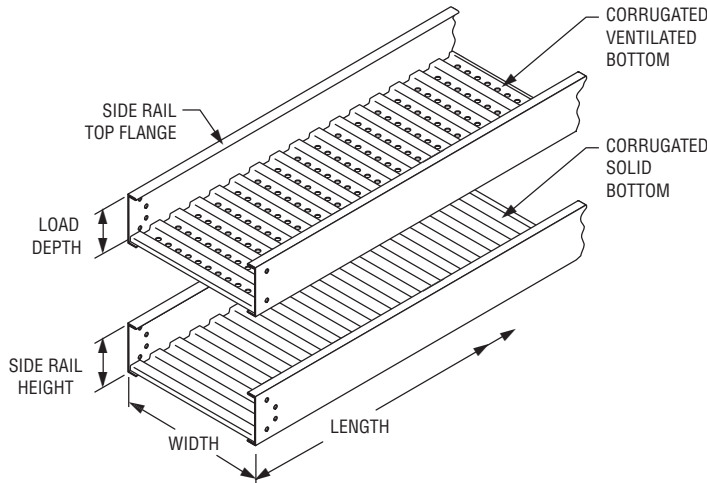

**AB-COPE TROF** is manufactured in 10' (CSA), 12', 20' (CSA) and 24' lengths; 6", 9", 12", 18", 24", 30" and 36" widths; and, 3", 4", 5", and 6" nominal load depths. A complete line of fittings and accessories are available.

Corrugated bottoms have 1" wide ribs on 2" centers. Ventilation holes in the valleys of the corrugations are 1 1/16" diameter on one inch (1") centers. Free passage of air through the openings results in a 68% open area. Corrugations give great lateral rigidity to the bottom transmitting the load to the side rails.

Solid Trof have the same corrugations but have no holes. Materials: Aluminum, Hot Dip-Mill galvanized (pre-galvanized) to ASTM A-924, Hot Dip Galvanized after Fabrication (HDGAF) to ASTM A-123.

Sufficient connectors are supplied to assemble straight sections and fittings for each order. Connectors for field cuts to be ordered separately.

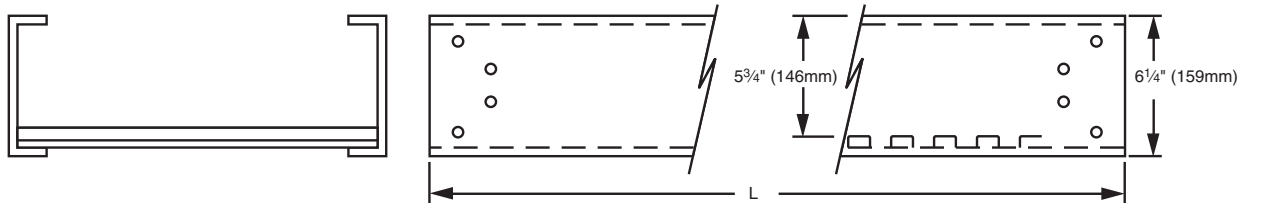

Catalog Number

| System               | Width           | Basic No. | Length  | Bottom Type     |  |
|----------------------|-----------------|-----------|---|-----------------|--|
| See Pages 136 to 139 | -06=6" (152mm)  | SL        | <b>NEMA</b><br>12' (3.7m)*<br>24' (7.3m)*<br>10' (3m)*<br>20' (6m)* | -S (solid)      |  |
|                      | -09=9" (229mm)  |           |   | -V (ventilated) |  |
|                      | -12=12" (305mm) |           |   |                 |  |
|                      |                 |           |   |                 |  |
|                      | -18=18" (457mm) |           | <b>CSA</b><br>-10' (3m)<br>-20' (6m)                                |                 |  |
|                      | -24=24" (610mm) |           |   |                 |  |
|                      | -30=30" (762mm) |           |   |                 |  |
|                      | -36=36" (914mm) |           |   |                 |  |
|                      |                 |           |   |                 |  |
|                      |                 |           |   |                 |  |

\*10', 12' all NEMA Classes, 20', 24' NEMA Classes 16A, 16B, 16C, 20A, 20B, 20C.  
EXAMPLE: 1B44-06SL-12-V is a 4" load depth aluminum Trof with 13/16" flange, 6" wide, 12' long, with ventilated bottom.

Conversion Table

| English     | 6"  | 9"  | 12" | 18" | 24" | 30" | 36" | 12'-0" | 24'-0" | 10'-0" | 20'-0" |
|-------------|-----|-----|-----|-----|-----|-----|-----|--------|--------|--------|--------|
| Metric (mm) | 152 | 229 | 305 | 457 | 610 | 762 | 914 | 3658   | 7316   | 3048   | 6096   |

### Material & Finish Specifications (AB-Cope Trof)

|                     | Pre-Galvanized Steel   | Hot-Dip Galvanized after Fabrication ASTM A-123          | Aluminum                | Type 304 Stainless Steel      |
|---------------------|--|--|-------------------------|-------------------------------|
| <b>Siderails</b>    | ASTM A-653-G90 CS (18 & 16 Gage)<br>ASTM A-653-G90 CS (14 & 12 Gage) | ASTM A-1008 (18 & 16 Gage)<br>ASTM A-1011 (14 & 12 Gage) | AA-6063-T6 Extruded     | ASTM A-240; Type 304          |
| <b>Bottom</b>       | ASTM A-653-G90 CS  | ASTM A-1008  | AA-6063-H34             | ASTM A-269; Type 304          |
| <b>Splice Plate</b> | ASTM A-1011  | ASTM A-1011  | AA-5052-H34             | ASTM A-240; Type 304          |
| <b>Finish</b>       | ASTM A-591 Class C   | ASTM A-123 Grade 65                                      |                         | 2B Finish (Typical)           |
| <b>Connector</b>    | SAE J429 Grade 1   | SAE J429 Grade 1   | SAE J429 Grade 1        |                               |
| <b>Bolts</b>        | (ASTM A-307 Grade A)   | (ASTM A-307 Grade A)                                     | (ASTM A-307 Grade A)    | AISI Type 304 Stainless Steel |
| <b>Bolt Plating</b> | ASTM B-633.0002" Zinc  | ASTM B-633.0002" Zinc                                    | ASTM B-633.0002" Zinc   |                               |
| <b>Covers</b>       | ASTM A-653-G90 CQ  | ASTM A-653-G90 CQ  | AA-3003 H14 or 3150 H14 | ASTM A-240; Type 304          |

## 90° Horizontal Elbow [9F]

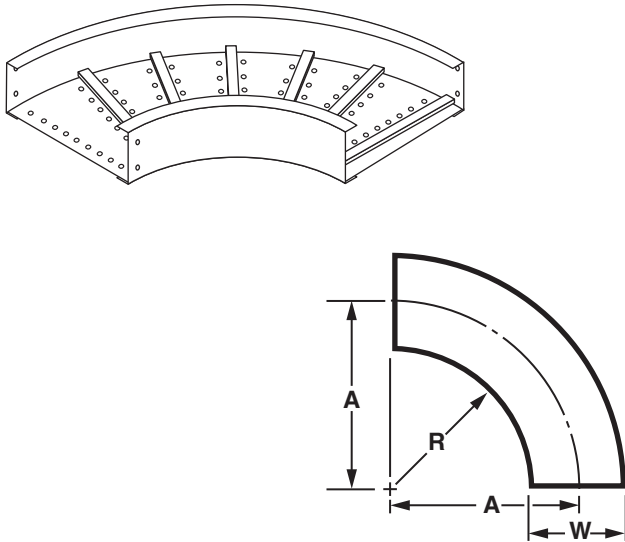

CSA Compliance for CSA Systems

| Radius - R     | Width - W   | "A" Dimension |  |
|----------------|-------------|---------------|--|
| 12"<br>(305mm) | 6" (152mm)  | 15" (381mm)   |  |
|                | 9" (229mm)  | 16½" (419mm)  |  |
|                | 12" (305mm) | 18" (457mm)   |  |
|                | 18" (457mm) | 21" (533mm)   |  |
|                | 24" (610mm) | 24" (610mm)   |  |
|                | 30" (762mm) | 27" (686mm)   |  |
| 24"<br>(610mm) | 36" (914mm) | 30" (762mm)   |  |
|                | 6" (152mm)  | 27" (686mm)   |  |
|                | 9" (229mm)  | 28½" (724mm)  |  |
|                | 12" (305mm) | 30" (762mm)   |  |
|                | 18" (457mm) | 33" (838mm)   |  |
|                | 24" (610mm) | 36" (914mm)   |  |
| 36"<br>(914mm) | 30" (762mm) | 39" (991mm)   |  |
|                | 36" (914mm) | 42" (1067mm)  |  |
|                | 6" (152mm)  | 39" (991mm)   |  |
|                | 9" (229mm)  | 40½" (1029mm) |  |
|                | 12" (305mm) | 42" (1067mm)  |  |
|                | 18" (457mm) | 45" (1143mm)  |  |
|                | 24" (610mm) | 48" (1219mm)  |  |
|                | 30" (762mm) | 51" (1295mm)  |  |
|                | 36" (914mm) | 54" (1372mm)  |  |

\*Add Suffix -V (vented) or -S (solid) to catalog number.

EXAMPLE: 234-129F-12-V

## 60° Horizontal Elbow [6F]

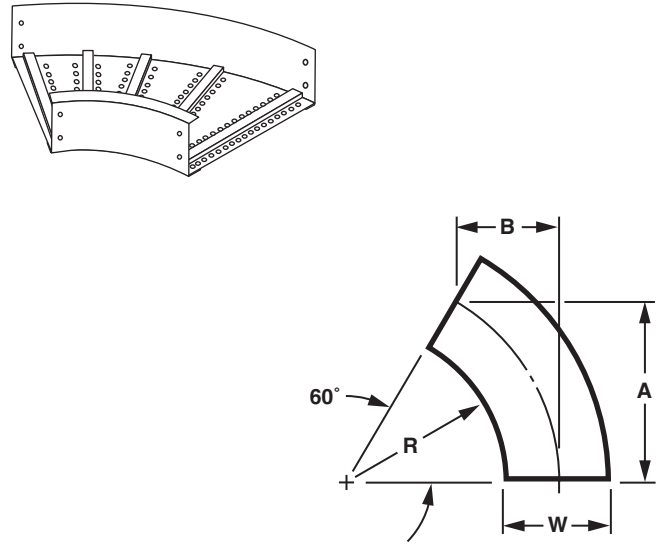

CSA Compliance for CSA Systems

| Radius - R     | Width - W   | "A" Dimension | "B" Dimension |
|----------------|-------------|---------------|---------------|
| 12"<br>(305mm) | 6" (152mm)  | 13" (330mm)   | 7½" (191mm)   |
|                | 9" (229mm)  | 14¼" (362mm)  | 8¼" (210mm)   |
|                | 12" (305mm) | 15⅝" (397mm)  | 9" (229mm)    |
|                | 18" (457mm) | 18¼" (464mm)  | 10½" (267mm)  |
|                | 24" (610mm) | 20¾" (527mm)  | 12" (305mm)   |
|                | 30" (762mm) | 23⅜" (594mm)  | 13½" (343mm)  |
| 24"<br>(610mm) | 36" (914mm) | 26" (660mm)   | 15" (381mm)   |
|                | 6" (152mm)  | 23⅜" (594mm)  | 13½" (343mm)  |
|                | 9" (229mm)  | 24¾" (629mm)  | 14¼" (362mm)  |
|                | 12" (305mm) | 26" (660mm)   | 15" (381mm)   |
|                | 18" (457mm) | 28⅝" (727mm)  | 16½" (416mm)  |
|                | 24" (610mm) | 31¼" (794mm)  | 18" (457mm)   |
| 36"<br>(914mm) | 30" (762mm) | 33¾" (857mm)  | 19½" (495mm)  |
|                | 36" (914mm) | 36⅜" (924mm)  | 21" (533mm)   |
|                | 6" (152mm)  | 33¾" (857mm)  | 19½" (495mm)  |
|                | 9" (229mm)  | 35⅛" (892mm)  | 20¼" (514mm)  |
|                | 12" (305mm) | 36⅜" (924mm)  | 21" (533mm)   |
|                | 18" (457mm) | 39" (991mm)   | 22½" (572mm)  |
|                | 24" (610mm) | 41⅝" (1057mm) | 24" (610mm)   |
|                | 30" (762mm) | 44⅛" (1121mm) | 25½" (648mm)  |
|                | 36" (914mm) | 46¾" (1187mm) | 27" (686mm)   |

\*Add suffix -V (vented) or -S (solid) to catalog number.

EXAMPLE: 234-126F-12-V

**Note:** When small or in-between angles are needed, use Cope's Adjustable Connectors.

### Ordering Information:

See Page 168 for Electrical Grounding Chart

Prefix No.

**[F] [D] [M] - [W] [Bp] - [R] - [B]**

**Flange Width** (2=1⅜", 4=1-¼")      **Load Depth** (3", 4", 5", 6")      **Basic Part (9F, 6F)**      **Bottom** (S=Solid, V=Ventilated)  
**Material Finish** (2=Mill-Galv, 3=HDAF, 4=Alum., U=304SS)      **Width** (06", 09", 12", 18", 24", 30", 36")      **Radius** (12", 24", 36")

## 45° Horizontal Elbow [4F]

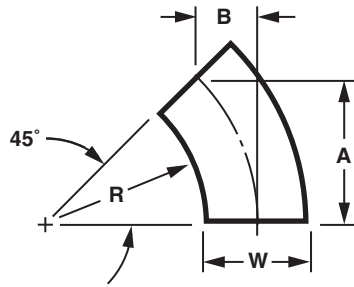
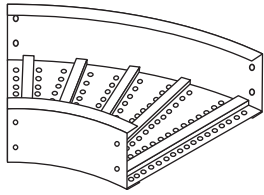

CSA Compliance for CSA Systems

| Radius - R     | Width - W   | "A"<br>Dimension                         | "B"<br>Dimension                         |
|----------------|-------------|--|--|
| 12"<br>(305mm) | 6" (152mm)  | 10 <sup>5</sup> / <sub>8</sub> " (270mm) | 4 <sup>3</sup> / <sub>8</sub> " (111mm)  |
|                | 9" (229mm)  | 11 <sup>5</sup> / <sub>8</sub> " (295mm) | 4 <sup>7</sup> / <sub>8</sub> " (124mm)  |
|                | 12" (305mm) | 12 <sup>3</sup> / <sub>4</sub> " (324mm) | 5 <sup>1</sup> / <sub>4</sub> " (133mm)  |
|                | 18" (457mm) | 14 <sup>7</sup> / <sub>8</sub> " (378mm) | 6 <sup>1</sup> / <sub>8</sub> " (156mm)  |
|                | 24" (610mm) | 17" (432mm)                              | 7" (178mm)                               |
|                | 30" (762mm) | 19 <sup>1</sup> / <sub>8</sub> " (486mm) | 7 <sup>7</sup> / <sub>8</sub> " (200mm)  |
| 24"<br>(610mm) | 36" (914mm) | 21 <sup>1</sup> / <sub>4</sub> " (540mm) | 8 <sup>3</sup> / <sub>4</sub> " (222mm)  |
|                | 6" (152mm)  | 19 <sup>1</sup> / <sub>8</sub> " (486mm) | 7 <sup>7</sup> / <sub>8</sub> " (200mm)  |
|                | 9" (229mm)  | 20 <sup>1</sup> / <sub>8</sub> " (511mm) | 8 <sup>3</sup> / <sub>8</sub> " (213mm)  |
|                | 12" (305mm) | 21 <sup>1</sup> / <sub>4</sub> " (540mm) | 8 <sup>3</sup> / <sub>4</sub> " (222mm)  |
|                | 18" (457mm) | 23 <sup>3</sup> / <sub>8</sub> " (594mm) | 9 <sup>5</sup> / <sub>8</sub> " (244mm)  |
|                | 24" (610mm) | 25 <sup>1</sup> / <sub>2</sub> " (702mm) | 10 <sup>1</sup> / <sub>2</sub> " (267mm) |
| 36"<br>(914mm) | 30" (762mm) | 27 <sup>5</sup> / <sub>8</sub> " (702mm) | 11 <sup>1</sup> / <sub>2</sub> " (292mm) |
|                | 36" (914mm) | 29 <sup>3</sup> / <sub>4</sub> " (756mm) | 12 <sup>3</sup> / <sub>8</sub> " (314mm) |
|                | 6" (152mm)  | 27 <sup>5</sup> / <sub>8</sub> " (702mm) | 11 <sup>1</sup> / <sub>2</sub> " (292mm) |
|                | 9" (229mm)  | 28 <sup>5</sup> / <sub>8</sub> " (727mm) | 11 <sup>7</sup> / <sub>8</sub> " (302mm) |
|                | 12" (305mm) | 29 <sup>3</sup> / <sub>4</sub> " (756mm) | 12 <sup>3</sup> / <sub>8</sub> " (314mm) |
|                | 18" (457mm) | 31 <sup>7</sup> / <sub>8</sub> " (810mm) | 13 <sup>1</sup> / <sub>4</sub> " (337mm) |
| 36"<br>(914mm) | 24" (610mm) | 34" (864mm)                              | 14 <sup>1</sup> / <sub>8</sub> " (359mm) |
|                | 30" (762mm) | 36 <sup>1</sup> / <sub>8</sub> " (918mm) | 15" (381mm)                              |
|                | 36" (914mm) | 38 <sup>1</sup> / <sub>4</sub> " (972mm) | 15 <sup>7</sup> / <sub>8</sub> " (403mm) |

\*Add suffix -V (vented) or -S (solid) to catalog number.

EXAMPLE: 234-124F-12-V

## 30° Horizontal Elbow [3F]

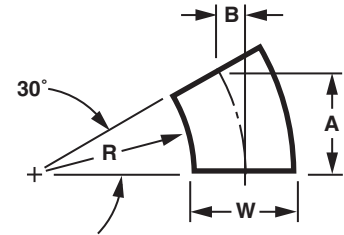
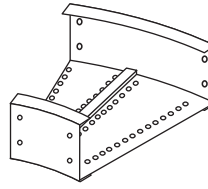

CSA Compliance for CSA Systems

| Radius - R     | Width - W   | "A"<br>Dimension                         | "B"<br>Dimension                        |
|----------------|-------------|--|---|
| 12"<br>(305mm) | 6" (152mm)  | 7 <sup>1</sup> / <sub>2</sub> " (191mm)  | 2" (51mm)                               |
|                | 9" (229mm)  | 8 <sup>1</sup> / <sub>4</sub> " (210mm)  | 2 <sup>1</sup> / <sub>4</sub> " (57mm)  |
|                | 12" (305mm) | 9" (229mm)                               | 2 <sup>3</sup> / <sub>8</sub> " (60mm)  |
|                | 18" (457mm) | 10 <sup>1</sup> / <sub>2</sub> " (267mm) | 2 <sup>7</sup> / <sub>8</sub> " (73mm)  |
|                | 24" (610mm) | 12" (305mm)                              | 3 <sup>1</sup> / <sub>4</sub> " (83mm)  |
|                | 30" (762mm) | 13 <sup>1</sup> / <sub>2</sub> " (343mm) | 3 <sup>5</sup> / <sub>8</sub> " (92mm)  |
| 24"<br>(610mm) | 36" (914mm) | 15" (381mm)                              | 4" (102mm)                              |
|                | 6" (152mm)  | 13 <sup>1</sup> / <sub>2</sub> " (343mm) | 3 <sup>5</sup> / <sub>8</sub> " (92mm)  |
|                | 9" (229mm)  | 14 <sup>1</sup> / <sub>4</sub> " (362mm) | 3 <sup>7</sup> / <sub>8</sub> " (98mm)  |
|                | 12" (305mm) | 15" (381mm)                              | 4" (102mm)                              |
|                | 18" (457mm) | 16 <sup>1</sup> / <sub>2</sub> " (419mm) | 4 <sup>3</sup> / <sub>8</sub> " (111mm) |
|                | 24" (610mm) | 18" (457mm)                              | 4 <sup>7</sup> / <sub>8</sub> " (124mm) |
| 36"<br>(914mm) | 30" (762mm) | 19 <sup>1</sup> / <sub>2</sub> " (495mm) | 5 <sup>1</sup> / <sub>4</sub> " (133mm) |
|                | 36" (914mm) | 21" (533mm)                              | 5 <sup>5</sup> / <sub>8</sub> " (143mm) |
|                | 6" (152mm)  | 19 <sup>1</sup> / <sub>2</sub> " (495mm) | 5 <sup>1</sup> / <sub>4</sub> " (133mm) |
|                | 9" (229mm)  | 20 <sup>1</sup> / <sub>4</sub> " (514mm) | 5 <sup>1</sup> / <sub>2</sub> " (140mm) |
|                | 12" (305mm) | 21" (533mm)                              | 5 <sup>5</sup> / <sub>8</sub> " (143mm) |
|                | 18" (457mm) | 22 <sup>1</sup> / <sub>2</sub> " (572mm) | 6" (152mm)                              |
| 36"<br>(914mm) | 24" (610mm) | 24" (610mm)                              | 6 <sup>1</sup> / <sub>2</sub> " (165mm) |
|                | 30" (762mm) | 25 <sup>1</sup> / <sub>2</sub> " (648mm) | 6 <sup>7</sup> / <sub>8</sub> " (175mm) |
|                | 36" (914mm) | 27" (686mm)                              | 7 <sup>1</sup> / <sub>4</sub> " (184mm) |

\*Add suffix -V (vented) or -S (solid) to catalog number.

EXAMPLE: 234-123F-12-V

**Note:** When small or in-between angles are needed, use Cope's Adjustable Connectors.

### Ordering Information:

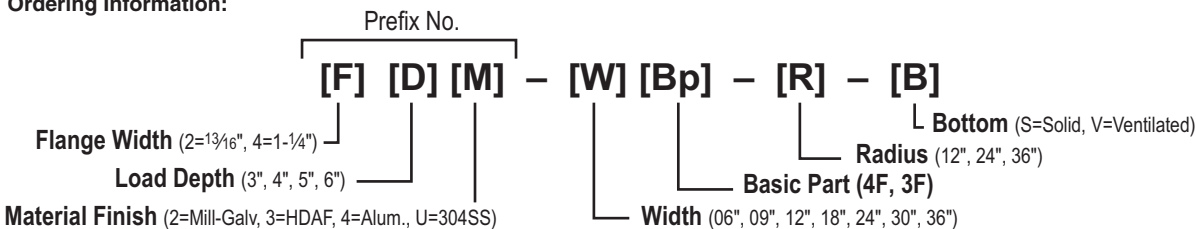

See Page 168  
for Electrical  
Grounding Chart

## Horizontal Tee [FT]

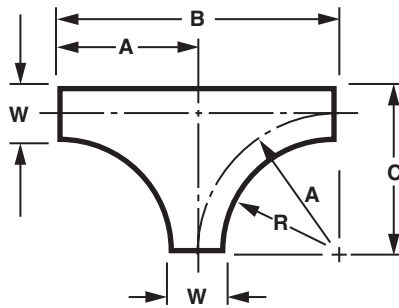
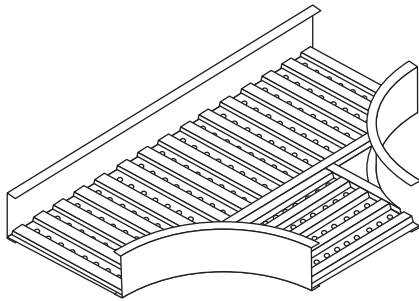

CSA Compliance for CSA Systems

| Radius - R     | Width - W   | "A" Dimension | "B" Dimension | "C" Dimension |
|----------------|-------------|---------------|---------------|---------------|
| 12"<br>(305mm) | 6" (152mm)  | 15" (381mm)   | 30" (762mm)   | 18" (457mm)   |
|                | 9" (229mm)  | 16½" (419mm)  | 33" (838mm)   | 21" (533mm)   |
|                | 12" (305mm) | 18" (457mm)   | 36" (914mm)   | 24" (610mm)   |
|                | 18" (457mm) | 21" (533mm)   | 42" (1067mm)  | 30" (762mm)   |
|                | 24" (610mm) | 24" (610mm)   | 48" (1219mm)  | 36" (914mm)   |
|                | 30" (762mm) | 27" (686mm)   | 54" (1372mm)  | 42" (1067mm)  |
| 24"<br>(610mm) | 36" (914mm) | 30" (762mm)   | 60" (1524mm)  | 48" (1219mm)  |
|                | 6" (152mm)  | 27" (686mm)   | 54" (1372mm)  | 30" (762mm)   |
|                | 9" (229mm)  | 28½" (724mm)  | 57" (1448mm)  | 33" (838mm)   |
|                | 12" (305mm) | 30" (762mm)   | 60" (1524mm)  | 36" (914mm)   |
|                | 18" (457mm) | 33" (838mm)   | 66" (1676mm)  | 42" (1067mm)  |
|                | 24" (610mm) | 36" (914mm)   | 72" (1829mm)  | 48" (1219mm)  |
| 36"<br>(914mm) | 30" (762mm) | 39" (991mm)   | 78" (1981mm)  | 54" (1372mm)  |
|                | 36" (914mm) | 42" (1067mm)  | 84" (2134mm)  | 60" (1524mm)  |
|                | 6" (152mm)  | 39" (991mm)   | 78" (1981mm)  | 42" (1067mm)  |
|                | 9" (229mm)  | 40½" (1029mm) | 81" (2057mm)  | 45" (1143mm)  |
|                | 12" (305mm) | 42" (1067mm)  | 84" (2134mm)  | 48" (1219mm)  |
|                | 18" (457mm) | 45" (1143mm)  | 90" (2286mm)  | 54" (1372mm)  |
| 36"<br>(914mm) | 24" (610mm) | 48" (1219mm)  | 96" (2438mm)  | 60" (1524mm)  |
|                | 30" (762mm) | 51" (1295mm)  | 102" (2591mm) | 66" (1676mm)  |
|                | 36" (914mm) | 54" (1372mm)  | 108" (2743mm) | 72" (1829mm)  |

\* Add suffix -V (vented) or -S (solid) to catalog number. - EXAMPLE: 234-12FT-12-V

## Horizontal Cross [FC]

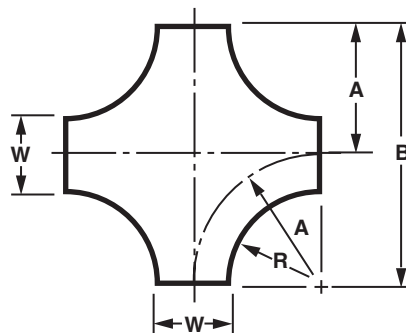
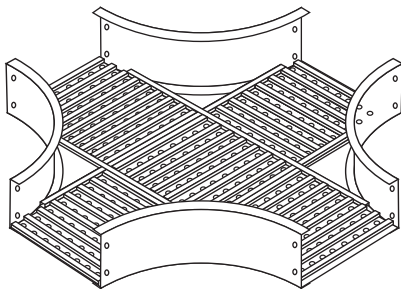

CSA Compliance for CSA Systems

| Radius - R     | Width - W   | "A" Dimension | "B" Dimension |
|----------------|-------------|---------------|---------------|
| 12"<br>(305mm) | 6" (152mm)  | 15" (381mm)   | 30" (762mm)   |
|                | 9" (229mm)  | 16½" (419mm)  | 33" (838mm)   |
|                | 12" (305mm) | 18" (457mm)   | 36" (914mm)   |
|                | 18" (457mm) | 21" (533mm)   | 42" (1067mm)  |
|                | 24" (610mm) | 24" (610mm)   | 48" (1219mm)  |
|                | 30" (762mm) | 27" (686mm)   | 54" (1372mm)  |
| 24"<br>(610mm) | 36" (914mm) | 30" (762mm)   | 60" (1524mm)  |
|                | 6" (152mm)  | 27" (686mm)   | 54" (1372mm)  |
|                | 9" (229mm)  | 28½" (724mm)  | 57" (1448mm)  |
|                | 12" (305mm) | 30" (762mm)   | 60" (1524mm)  |
|                | 18" (457mm) | 33" (838mm)   | 66" (1676mm)  |
|                | 24" (610mm) | 36" (914mm)   | 72" (1829mm)  |
| 36"<br>(914mm) | 30" (762mm) | 39" (991mm)   | 78" (1981mm)  |
|                | 36" (914mm) | 42" (1067mm)  | 84" (2134mm)  |
|                | 6" (152mm)  | 39" (991mm)   | 78" (1981mm)  |
|                | 9" (229mm)  | 40½" (1029mm) | 81" (2057mm)  |
|                | 12" (305mm) | 42" (1067mm)  | 84" (2134mm)  |
|                | 18" (457mm) | 45" (1143mm)  | 90" (2286mm)  |
| 36"<br>(914mm) | 24" (610mm) | 48" (1219mm)  | 96" (2438mm)  |
|                | 30" (762mm) | 51" (1295mm)  | 102" (2591mm) |
|                | 36" (914mm) | 54" (1372mm)  | 108" (2743mm) |

\* Add suffix -V (vented) or -S (solid) to catalog number. - EXAMPLE: 234-12FC-12-V

### Ordering Information:

See Page 168  
for Electrical  
Grounding Chart

Prefix No.

**[F] [D] [M] - [W] [Bp] - [R] - [B]**

Flange Width (2=13/16", 4=1-1/4")
Width (06", 09", 12", 18", 24", 30", 36")
Bottom (S=Solid, V=Vented)

Load Depth (3", 4", 5", 6")
Radius (12", 24", 36")

Material Finish (2=Mill-Galv, 3=HDAF, 4=Alum., U=304SS)
Basic Part (FT, FC)

## Horizontal Tapped Tee [TT]

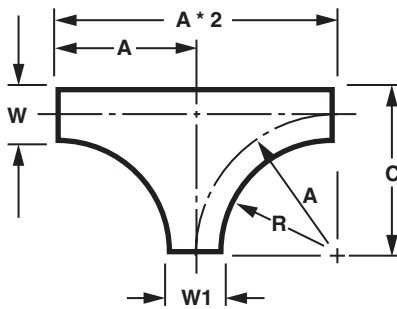
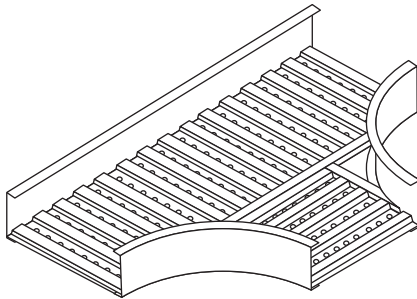

CSA Compliance for CSA Systems

| R Radius       | W Width        | W1 Width        | "A" Dimension   | "C" Dimension   |
|----------------|----------------|-----------------|-----------------|-----------------|
| 12"<br>(305mm) | 36"<br>(914mm) | 30" (762mm)     | 27" (686mm)     | 48"<br>(1219mm) |
|                |                | 24" (610mm)     | 24" (610mm)     |                 |
|                |                | 18" (457mm)     | 21" (533mm)     |                 |
|                |                | 12" (305mm)     | 18" (457mm)     |                 |
|                |                | 9" (229mm)      | 16 1/2" (419mm) |                 |
|                |                | 6" (152mm)      | 15" (381mm)     |                 |
|                | 30"<br>(762mm) | 24" (610mm)     | 24" (610mm)     | 42"<br>(1067mm) |
|                |                | 18" (457mm)     | 21" (533mm)     |                 |
|                |                | 12" (305mm)     | 18" (457mm)     |                 |
|                | 24"<br>(610mm) | 9" (229mm)      | 16 1/2" (419mm) | 36"<br>(914mm)  |
|                |                | 6" (152mm)      | 15" (381mm)     |                 |
|                |                | 18" (457mm)     | 21" (533mm)     |                 |
| 12" (305mm)    |                | 18" (457mm)     |                 |                 |
| 18"<br>(457mm) | 9" (229mm)     | 16 1/2" (419mm) | 30"<br>(762mm)  |                 |
|                | 6" (152mm)     | 15" (381mm)     |                 |                 |
|                | 12" (305mm)    | 18" (457mm)     |                 |                 |
| 12"<br>(305mm) | 9" (229mm)     | 16 1/2" (419mm) | 24"<br>(610mm)  |                 |
|                | 6" (152mm)     | 15" (381mm)     |                 |                 |
| 9"<br>(229mm)  | 6" (152mm)     | 15" (381mm)     | 21"<br>(533mm)  |                 |

EXAMPLE: 234-12TT-09-12

**Note:** Nominal 9" rung spacing maintained through centerline of all fittings.

**Ordering Information:**

See Page 62 for Electrical Grounding Chart

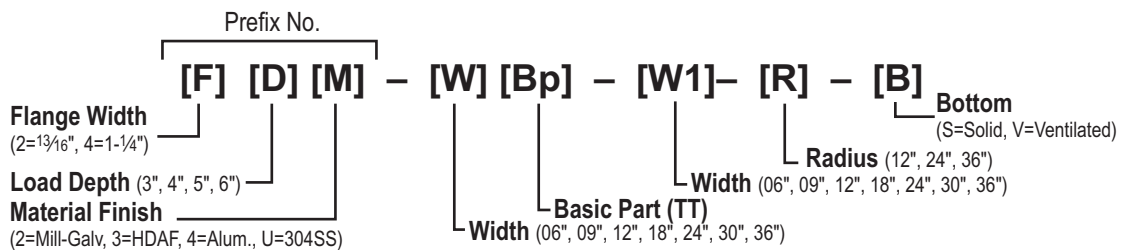

## Horizontal Tapped Tee [TT] (cont.)

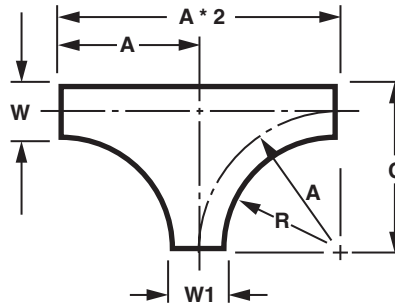

CSA Compliance for CSA Systems

| R Radius       | W Width        | W1 Width    | "A" Dimension   | "C" Dimension   |                 |
|----------------|----------------|-------------|-----------------|-----------------|-----------------|
| 24"<br>(610mm) | 36"<br>(914mm) | 30" (762mm) | 39" (991mm)     | 60"<br>(1524mm) |                 |
|                |                | 24" (610mm) | 36" (914mm)     |                 |                 |
|                |                | 18" (457mm) | 33" (838mm)     |                 |                 |
|                |                | 12" (305mm) | 30" (762mm)     |                 |                 |
|                |                | 9" (229mm)  | 28 1/2" (724mm) |                 |                 |
|                |                | 6" (152mm)  | 27" (686mm)     |                 |                 |
|                | 30"<br>(762mm) | 24" (610mm) | 36" (914mm)     | 54"<br>(1372mm) |                 |
|                |                | 18" (457mm) | 33" (838mm)     |                 |                 |
|                |                | 12" (305mm) | 30" (762mm)     |                 |                 |
|                | 24"<br>(610mm) | 18" (457mm) | 12" (305mm)     | 30" (762mm)     | 48"<br>(1219mm) |
|                |                |             | 9" (229mm)      | 28 1/2" (724mm) |                 |
|                |                |             | 6" (152mm)      | 27" (686mm)     |                 |
| 12" (305mm)    |                |             | 30" (762mm)     |                 |                 |
| 18"<br>(457mm) | 12" (305mm)    | 9" (229mm)  | 28 1/2" (724mm) | 42"<br>(1067mm) |                 |
|                |                | 6" (152mm)  | 27" (686mm)     |                 |                 |
|                |                | 9" (229mm)  | 28 1/2" (724mm) |                 |                 |
| 12"<br>(305mm) | 9" (229mm)     | 6" (152mm)  | 27" (686mm)     | 36"<br>(914mm)  |                 |
|                |                | 6" (152mm)  | 27" (686mm)     |                 |                 |
| 9"<br>(229mm)  | 6" (152mm)     | 27" (686mm) | 33"<br>(838mm)  | 33"<br>(838mm)  |                 |

CSA Compliance for CSA Systems

| R Radius       | W Width        | W1 Width    | "A" Dimension    | "C" Dimension    |                 |
|----------------|----------------|-------------|------------------|------------------|-----------------|
| 36"<br>(914mm) | 36"<br>(914mm) | 30" (762mm) | 51" (1295mm)     | 72"<br>(1829mm)  |                 |
|                |                | 24" (610mm) | 48" (1219mm)     |                  |                 |
|                |                | 18" (457mm) | 45" (1143mm)     |                  |                 |
|                |                | 12" (305mm) | 42" (1067mm)     |                  |                 |
|                |                | 9" (229mm)  | 40 1/2" (1029mm) |                  |                 |
|                |                | 6" (152mm)  | 39" (991mm)      |                  |                 |
|                | 30"<br>(762mm) | 24" (610mm) | 18" (457mm)      | 48" (1219mm)     | 66"<br>(1676mm) |
|                |                |             | 12" (305mm)      | 42" (1067mm)     |                 |
|                |                |             | 9" (229mm)       | 40 1/2" (1029mm) |                 |
|                |                |             | 6" (152mm)       | 39" (991mm)      |                 |
|                | 24"<br>(610mm) | 18" (457mm) | 12" (305mm)      | 45" (1143mm)     | 60"<br>(1524mm) |
|                |                |             | 9" (229mm)       | 42" (1067mm)     |                 |
| 6" (152mm)     |                |             | 40 1/2" (1029mm) |                  |                 |
| 12" (305mm)    |                |             | 39" (991mm)      |                  |                 |
| 18"<br>(457mm) | 12" (305mm)    | 9" (229mm)  | 42" (1067mm)     | 54"<br>(1372mm)  |                 |
|                |                | 6" (152mm)  | 40 1/2" (1029mm) |                  |                 |
|                |                | 9" (229mm)  | 39" (991mm)      |                  |                 |
| 12"<br>(305mm) | 9" (229mm)     | 6" (152mm)  | 40 1/2" (1029mm) | 48"<br>(1219mm)  |                 |
|                |                | 6" (152mm)  | 39" (991mm)      |                  |                 |
| 9"<br>(229mm)  | 6" (152mm)     | 27" (686mm) | 39" (991mm)      | 45"<br>(1143mm)  |                 |

## Horizontal Tapped Cross [TC]

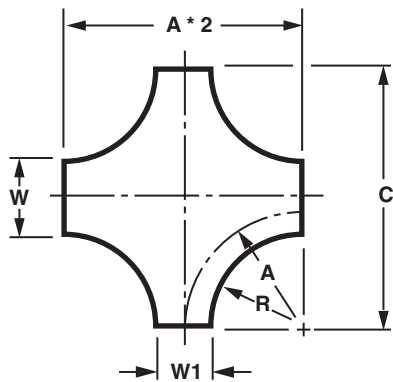
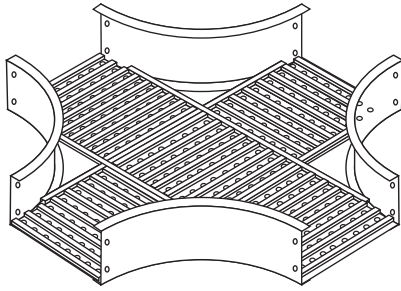

CSA Compliance for CSA Systems

| R Radius       | W Width        | W1 Width       | "A" Dimension   | "C" Dimension   |                 |                 |
|----------------|----------------|----------------|-----------------|-----------------|-----------------|-----------------|
| 12"<br>(305mm) | 36"<br>(914mm) | 30" (762mm)    | 27" (686mm)     | 60"<br>(1524mm) |                 |                 |
|                |                | 24" (610mm)    | 24" (610mm)     |                 |                 |                 |
|                |                | 18" (457mm)    | 21" (533mm)     |                 |                 |                 |
|                |                | 12" (305mm)    | 18" (457mm)     |                 |                 |                 |
|                |                | 9" (229mm)     | 16 1/2" (419mm) |                 |                 |                 |
|                |                | 6" (152mm)     | 15" (381mm)     |                 |                 |                 |
|                | 30"<br>(762mm) | 24" (610mm)    | 24" (610mm)     | 54"<br>(1372mm) |                 |                 |
|                |                | 18" (457mm)    | 21" (533mm)     |                 |                 |                 |
|                |                | 12" (305mm)    | 18" (457mm)     |                 |                 |                 |
|                |                | 9" (229mm)     | 16 1/2" (419mm) |                 |                 |                 |
|                |                | 6" (152mm)     | 15" (381mm)     |                 |                 |                 |
|                |                | 24"<br>(610mm) | 18" (457mm)     |                 | 21" (533mm)     | 48"<br>(1219mm) |
|                | 12" (305mm)    |                | 18" (457mm)     |                 |                 |                 |
|                | 9" (229mm)     |                | 16 1/2" (419mm) |                 |                 |                 |
|                | 6" (152mm)     |                | 15" (381mm)     |                 |                 |                 |
|                | 18"<br>(457mm) |                | 12" (305mm)     | 18" (457mm)     | 42"<br>(1067mm) |                 |
|                |                |                | 9" (229mm)      | 16 1/2" (419mm) |                 |                 |
|                |                | 6" (152mm)     | 15" (381mm)     |                 |                 |                 |
|                | 12"<br>(305mm) | 9" (229mm)     | 16 1/2" (419mm) | 36"<br>(914mm)  |                 |                 |
|                |                | 6" (152mm)     | 15" (381mm)     |                 |                 |                 |
|                | 9"<br>(229mm)  | 6" (152mm)     | 15" (381mm)     | 33"<br>(838mm)  |                 |                 |

EXAMPLE: 234-36TC-18-12

**Note:** Nominal 9" rung spacing maintained through centerline of all fittings.

**Ordering Information:**

See Page 62 for Electrical Grounding Chart

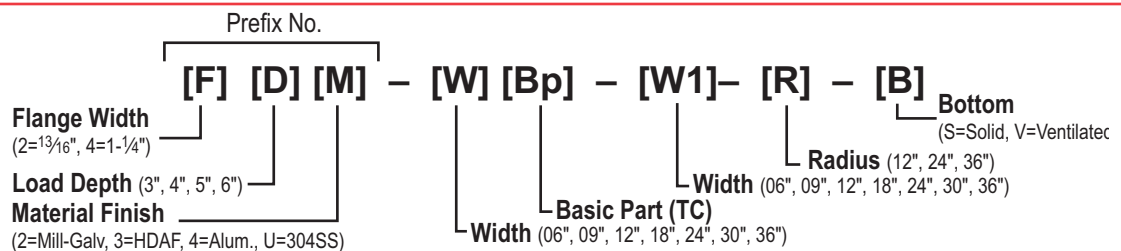

## Horizontal Tapped Cross [TC] (cont.)

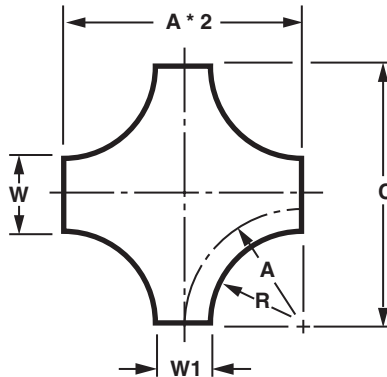

CSA Compliance for CSA Systems

| R Radius       | W Width        | W1 Width    | "A" Dimension   | "C" Dimension   |
|----------------|----------------|-------------|-----------------|-----------------|
| 24"<br>(610mm) | 36"<br>(914mm) | 30" (762mm) | 39" (991mm)     | 84"<br>(2134mm) |
|                |                | 24" (610mm) | 36" (914mm)     |                 |
|                |                | 18" (457mm) | 33" (838mm)     |                 |
|                |                | 12" (305mm) | 30" (762mm)     |                 |
|                |                | 9" (229mm)  | 28½" (724mm)    |                 |
|                |                | 6" (152mm)  | 27" (686mm)     |                 |
|                | 30"<br>(762mm) | 24" (610mm) | 36" (914mm)     | 78"<br>(1981mm) |
|                |                | 18" (457mm) | 33" (838mm)     |                 |
|                |                | 12" (305mm) | 30" (762mm)     |                 |
|                |                | 9" (229mm)  | 28½" (724mm)    |                 |
|                | 24"<br>(610mm) | 18" (457mm) | 12" (305mm)     | 72"<br>(1829mm) |
|                |                |             | 9" (229mm)      |                 |
| 12" (305mm)    |                | 9" (229mm)  | 66"<br>(1676mm) |                 |
|                |                | 6" (152mm)  |                 |                 |
| 18"<br>(457mm) | 12" (305mm)    | 9" (229mm)  | 60"<br>(1524mm) |                 |
|                |                | 6" (152mm)  |                 | 27" (686mm)     |
|                | 9" (229mm)     | 9" (229mm)  |                 | 57"<br>(1448mm) |
|                |                | 6" (152mm)  |                 |                 |

CSA Compliance for CSA Systems

| R Radius       | W Width        | W1 Width    | "A" Dimension   | "C" Dimension    |                 |
|----------------|----------------|-------------|-----------------|------------------|-----------------|
| 36"<br>(914mm) | 36"<br>(914mm) | 30" (762mm) | 51" (1295mm)    | 108"<br>(2743mm) |                 |
|                |                | 24" (610mm) | 48" (1219mm)    |                  |                 |
|                |                | 18" (457mm) | 45" (1143mm)    |                  |                 |
|                |                | 12" (305mm) | 42" (1067mm)    |                  |                 |
|                |                | 9" (229mm)  | 40½" (1029mm)   |                  |                 |
|                |                | 6" (152mm)  | 39" (991mm)     |                  |                 |
|                | 30"<br>(762mm) | 24" (610mm) | 18" (457mm)     | 102"<br>(2591mm) |                 |
|                |                |             | 12" (305mm)     |                  | 42" (1067mm)    |
|                |                | 18" (457mm) | 9" (229mm)      |                  | 96"<br>(2438mm) |
|                |                |             | 6" (152mm)      |                  |                 |
|                | 24"<br>(610mm) | 18" (457mm) | 12" (305mm)     | 90"<br>(2286mm)  |                 |
|                |                |             | 9" (229mm)      |                  | 40½" (1029mm)   |
| 12" (305mm)    |                | 9" (229mm)  | 84"<br>(2134mm) |                  |                 |
|                |                | 6" (152mm)  |                 |                  | 39" (991mm)     |
| 18"<br>(457mm) | 12" (305mm)    | 9" (229mm)  | 81"<br>(2057mm) |                  |                 |
|                |                | 6" (152mm)  |                 | 39" (991mm)      |                 |
|                | 9" (229mm)     | 9" (229mm)  |                 | 81"<br>(2057mm)  |                 |
|                |                | 6" (152mm)  |                 |                  | 39" (991mm)     |

## Straight Reducer [ST]

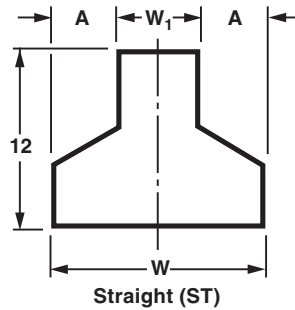
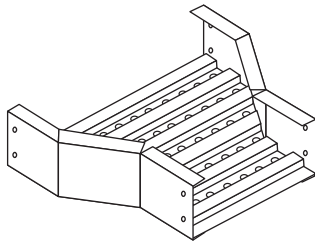

## Left Hand [LH] & Right Hand [RH] Reducer

### LEFT HAND (LH)

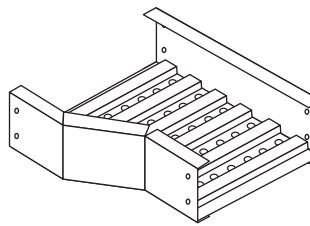

### RIGHT HAND (RH)

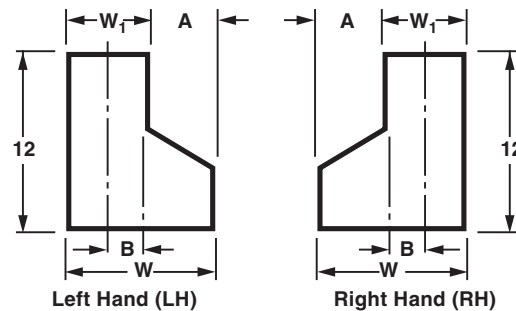
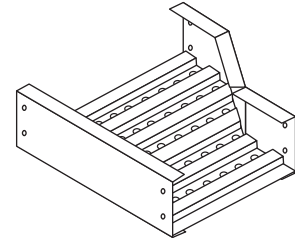

### CSA Compliance for CSA Systems

| Width - W             | Width - W1  | "A" Dimension   |                 |
|-----------------------|-------------|-----------------|-----------------|
| <b>36"</b><br>(914mm) | 30" (762mm) | 3" (76mm)       | 6" (152mm)      |
|                       | 24" (610mm) | 6" (152mm)      | 9" (229mm)      |
|                       | 18" (457mm) | 9" (229mm)      | 12" (305mm)     |
|                       | 12" (305mm) | 13 1/2" (343mm) | 15" (381mm)     |
|                       | 9" (229mm)  | 15" (381mm)     |                 |
| <b>30"</b><br>(762mm) | 24" (610mm) | 3" (76mm)       | 6" (152mm)      |
|                       | 18" (457mm) | 6" (152mm)      | 9" (229mm)      |
|                       | 12" (305mm) | 9" (229mm)      | 10 1/2" (267mm) |
|                       | 9" (229mm)  | 12" (304mm)     |                 |
|                       | 6" (152mm)  |                 |                 |
| <b>24"</b><br>(610mm) | 18" (457mm) | 3" (76mm)       | 6" (152mm)      |
|                       | 12" (305mm) | 6" (152mm)      | 7 1/2" (191mm)  |
|                       | 9" (229mm)  | 9" (229mm)      |                 |
|                       | 6" (152mm)  |                 |                 |
| <b>18"</b><br>(457mm) | 12" (305mm) | 3" (76mm)       | 4 1/2" (114mm)  |
|                       | 9" (229mm)  | 6" (152mm)      |                 |
|                       | 6" (152mm)  |                 |                 |
| <b>12"</b><br>(305mm) | 9" (229mm)  | 1 1/2" (38mm)   | 3" (76mm)       |
|                       | 6" (152mm)  |                 |                 |
| <b>9"</b><br>(229mm)  | 6" (152mm)  | 1 1/2" (38mm)   |                 |

\*Add suffix -V (vented) or -S (solid) to catalog number.  
EXAMPLE: 234-36ST-12-V

### CSA Compliance for CSA Systems

| Width - W             | "W1" Dim.   | "A" Dim.    | "B" Dim.       |
|-----------------------|-------------|-------------|----------------|
| <b>36"</b><br>(914mm) | 30" (914mm) | 6" (152mm)  | 15" (381mm)    |
|                       | 24" (610mm) | 12" (305mm) | 12" (305mm)    |
|                       | 18" (457mm) | 18" (457mm) | 9" (229mm)     |
|                       | 12" (305mm) | 24" (610mm) | 6" (152mm)     |
|                       | 9" (229mm)  | 27" (686mm) | 4 1/2" (114mm) |
|                       | 6" (152mm)  | 30" (762mm) | 3" (76mm)      |
| <b>30"</b><br>(762mm) | 24" (610mm) | 6" (152mm)  | 12" (305mm)    |
|                       | 18" (457mm) | 12" (305mm) | 9" (229mm)     |
|                       | 12" (305mm) | 18" (457mm) | 6" (152mm)     |
|                       | 9" (229mm)  | 21" (533mm) | 4 1/2" (114mm) |
|                       | 6" (152mm)  | 24" (610mm) | 3" (76mm)      |
|                       |             |             |                |
| <b>24"</b><br>(610mm) | 18" (457mm) | 6" (152mm)  | 9" (229mm)     |
|                       | 12" (305mm) | 12" (305mm) | 6" (152mm)     |
|                       | 9" (229mm)  | 15" (381mm) | 4 1/2" (114mm) |
|                       | 6" (152mm)  | 18" (457mm) | 3" (76mm)      |
| <b>18"</b><br>(457mm) | 12" (305mm) | 6" (152mm)  | 6" (152mm)     |
|                       | 9" (229mm)  | 9" (229mm)  | 4 1/2" (114mm) |
|                       | 6" (152mm)  | 12" (305mm) | 3" (76mm)      |
| <b>12"</b><br>(305mm) | 9" (229mm)  | 3" (76mm)   | 4 1/2" (114mm) |
|                       | 6" (152mm)  | 6" (152mm)  | 3" (76mm)      |
| <b>9"</b><br>(229mm)  | 6" (152mm)  | 3" (76mm)   | 3" (76mm)      |

\*Add suffix -V (vented) or -S (solid) to catalog number.  
EXAMPLE: 234-36LH-12-V

### Ordering Information:

Prefix No.

[F] [D] [M] - [W] [Bp] - [W<sub>1</sub>] - [B]

Flange Width (2=13/16", 4=1-1/4")

Load Depth (3", 4", 5", 6")

Material Finish (2=Mill-Galv, 3=HDAF, 4=Alum., U=304SS)

Bottom (S=Solid, V=Ventilated)  
Reduced Width (06", 09", 12", 18", 24", 30")

Basic Part (ST, LH, RH)

Width (06", 09", 12", 18", 24", 30", 36")

See Page 168  
for Electrical  
Grounding Chart

## Adjustable Elbow [AF]

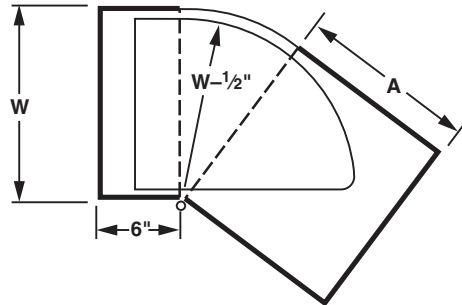
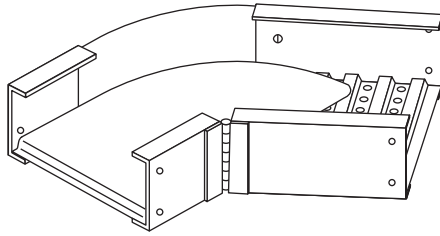

### CSA Compliance for CSA Systems

| Width - W |         | "A" Dimension |         |
|-----------|---------|---------------|---------|
| 6"        | (152mm) | 8"            | (203mm) |
| 9"        | (229mm) | 11"           | (279mm) |
| 12"       | (305mm) | 14"           | (356mm) |
| 18"       | (457mm) | 20"           | (508mm) |
| 24"       | (610mm) | 26"           | (660mm) |
| 30"       | (762mm) | 32"           | (813mm) |
| 36"       | (914mm) | 38"           | (965mm) |

Both rails at hinge break to be bonded if fitting is used as equipment grounding conductor. \* Add suffix -V (vented) or -S (solid) to catalog number.

EXAMPLE: 234-12AF-V

## 45° "Y" Branch Left [LY] & Right [RY]

### RIGHT HAND [RY] SHOWN

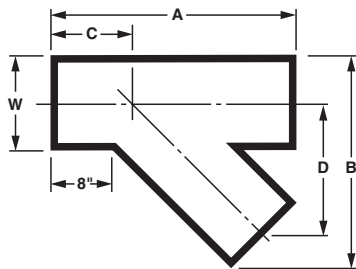
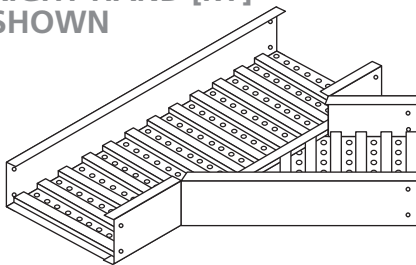

### CSA Compliance for CSA Systems

| Width - W   | "A" Dim.         | "B" Dim.         | "C" Dim.        | "D" Dim.        |
|-------------|------------------|------------------|-----------------|-----------------|
| 6" (152mm)  | 22 1/2" (571mm)  | 16 1/4" (413mm)  | 11 3/8" (289mm) | 11 1/8" (283mm) |
| 9" (229mm)  | 26 3/4" (679mm)  | 21 3/8" (543mm)  | 13" (330mm)     | 13 3/4" (349mm) |
| 12" (305mm) | 31" (787mm)      | 26 1/2" (673mm)  | 14 3/4" (375mm) | 16 1/4" (412mm) |
| 18" (457mm) | 39 1/2" (1003mm) | 36 3/4" (933mm)  | 18 1/8" (460mm) | 21 3/8" (543mm) |
| 24" (610mm) | 48" (1219mm)     | 47" (1193mm)     | 21 1/2" (546mm) | 26 1/2" (673mm) |
| 30" (762mm) | 56 3/8" (1432mm) | 57 1/4" (1454mm) | 24 3/4" (629mm) | 31 5/8" (803mm) |
| 36" (914mm) | 65" (1651mm)     | 67 1/2" (1714mm) | 28 1/4" (718mm) | 36 3/4" (933mm) |

\*Add suffix -V (vented) or -S (solid) to catalog number.

EXAMPLE: 234-12RY-V

**Note:** AB-COPE FITTINGS are offered in 12", 24", and 36" radius. When small or in-between angles are needed, use AB-Cope's Adjustable Connectors.

### Ordering Information:

See Page 168  
for Electrical  
Grounding Chart

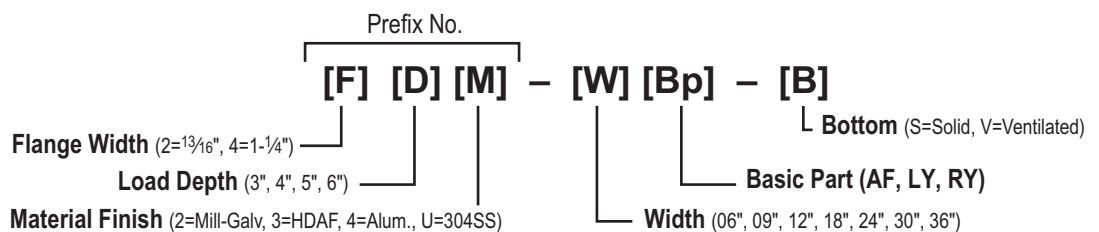

## 90° Vertical Elbow Outside [90] & Inside [9I]

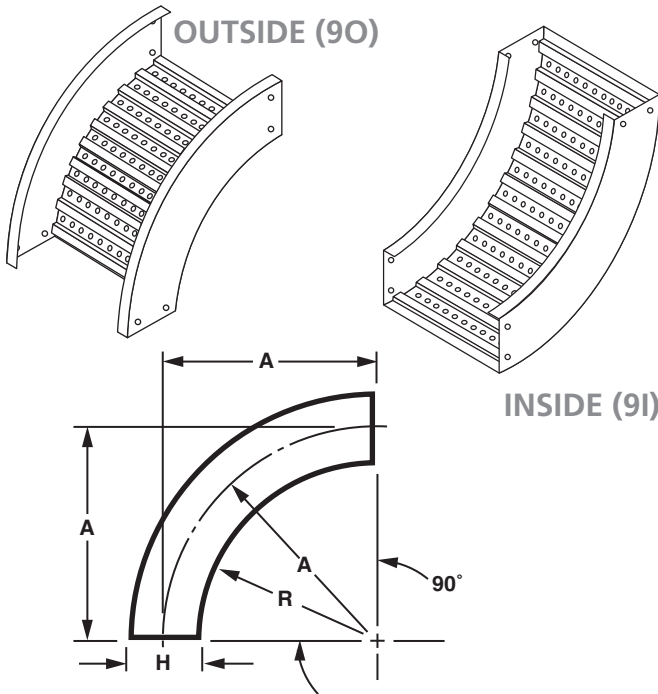

CSA Compliance for CSA Systems

| Radius - R     | "H" Dim.       | "A" Dim.        |
|----------------|----------------|-----------------|
| 12"<br>(305mm) | 3 1/2" (89mm)  | 13 3/4" (349mm) |
|                | 4 1/4" (108mm) | 14 1/8" (359mm) |
|                | 5 1/4" (133mm) | 14 5/8" (372mm) |
| 24"<br>(610mm) | 6 1/4" (159mm) | 15 1/8" (384mm) |
|                | 3 1/2" (89mm)  | 25 3/4" (654mm) |
|                | 4 1/4" (108mm) | 26 1/8" (664mm) |
| 36"<br>(914mm) | 5 1/4" (133mm) | 26 5/8" (676mm) |
|                | 6 1/4" (159mm) | 27 1/8" (689mm) |
|                | 3 1/2" (89mm)  | 37 3/4" (959mm) |
|                | 4 1/4" (108mm) | 36 1/8" (969mm) |
|                | 5 1/4" (133mm) | 36 5/8" (981mm) |
|                | 6 1/4" (159mm) | 39 1/8" (994mm) |

\*Add suffix -V (vented) or -S (solid) to catalog number.

EXAMPLE: 234-1290-12-V

## 60° Vertical Elbow Outside [60] & Inside [6I]

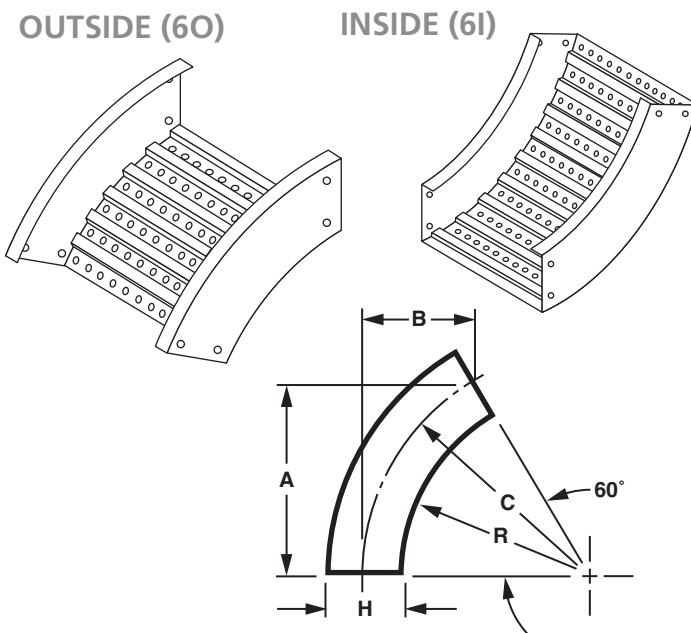

CSA Compliance for CSA Systems

| Radius - R     | "H" Dim.       | "A" Dim.        | "B" Dim.        | "C" Dim.        |
|----------------|----------------|-----------------|-----------------|-----------------|
| 12"<br>(305mm) | 3 1/2" (89mm)  | 11 7/8" (302mm) | 6 7/8" (175mm)  | 13 3/4" (349mm) |
|                | 4 1/4" (108mm) | 12 1/4" (311mm) | 7 1/8" (181mm)  | 14 1/8" (359mm) |
|                | 5 1/4" (133mm) | 12 5/8" (321mm) | 7 3/8" (187mm)  | 14 5/8" (372mm) |
| 24"<br>(610mm) | 6 1/4" (159mm) | 13 1/8" (334mm) | 7 5/8" (194mm)  | 15 1/8" (384mm) |
|                | 3 1/2" (89mm)  | 22 1/4" (565mm) | 12 7/8" (327mm) | 25 3/4" (654mm) |
|                | 4 1/4" (108mm) | 22 5/8" (575mm) | 13 1/8" (334mm) | 26 1/8" (664mm) |
| 36"<br>(914mm) | 5 1/4" (133mm) | 23 1/8" (588mm) | 13 3/8" (340mm) | 26 5/8" (676mm) |
|                | 6 1/4" (159mm) | 23 1/2" (597mm) | 13" (330mm)     | 27 1/8" (689mm) |
|                | 3 1/2" (89mm)  | 32 3/4" (832mm) | 18 7/8" (480mm) | 37 3/4" (959mm) |
|                | 4 1/4" (108mm) | 33" (838mm)     | 19 1/8" (486mm) | 38 1/8" (969mm) |
|                | 5 1/4" (133mm) | 33 1/2" (851mm) | 19 3/8" (492mm) | 38 5/8" (981mm) |
|                | 6 1/4" (159mm) | 33 7/8" (861mm) | 19 5/8" (499mm) | 39 1/8" (994mm) |

\*Add suffix -V (vented) or -S (solid) to catalog number.

EXAMPLE: 234-1260-12-V

**Note:** AB-COPE FITTINGS are offered in 12", 24" and 36" radius. When small or in-between angles are needed, use AB-Cope's Adjustable Connectors.

### Ordering Information:

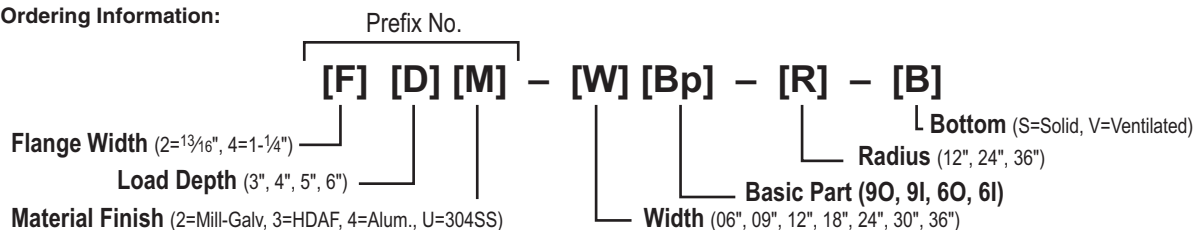

See Page 168  
for Electrical  
Grounding Chart

## 45° Vertical Elbow Outside [40] & Inside [41]

### OUTSIDE (40)

### INSIDE (41)

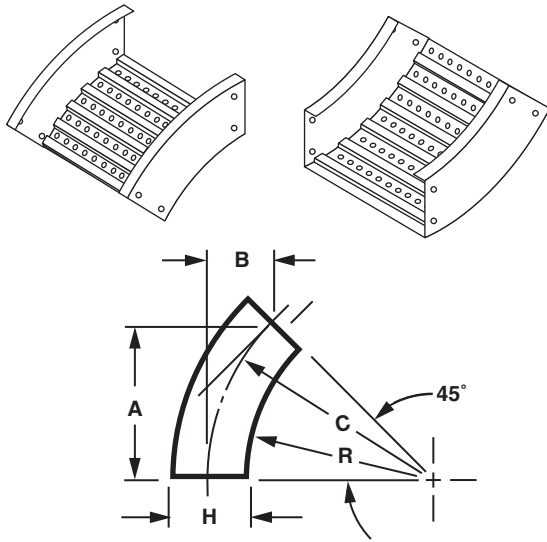

### CSA Compliance for CSA Systems

| Radius - R     | "H" Dim.       | "A" Dim.        | "B" Dim.        | "C" Dim.        |
|----------------|----------------|-----------------|-----------------|-----------------|
| 12"<br>(305mm) | 3 1/2" (89mm)  | 9 3/4" (248mm)  | 4" (102mm)      | 13 3/4" (349mm) |
|                | 4 1/4" (108mm) | 10" (254mm)     | 4 1/8" (105mm)  | 14 1/8" (359mm) |
|                | 5 1/4" (133mm) | 10 3/8" (264mm) | 4 1/4" (108mm)  | 14 5/8" (372mm) |
| 24"<br>(610mm) | 6 1/4" (159mm) | 10 3/4" (273mm) | 4 1/2" (114mm)  | 15 1/8" (384mm) |
|                | 3 1/2" (89mm)  | 18 1/4" (464mm) | 7 1/2" (191mm)  | 25 3/4" (654mm) |
|                | 4 1/4" (108mm) | 18 1/2" (470mm) | 7 5/8" (194mm)  | 26 1/8" (664mm) |
| 36"<br>(914mm) | 5 1/4" (133mm) | 18 7/8" (480mm) | 7 7/8" (200mm)  | 26 5/8" (676mm) |
|                | 6 1/4" (159mm) | 19 1/4" (489mm) | 8" (203mm)      | 27 1/8" (689mm) |
|                | 3 1/2" (89mm)  | 26 3/4" (679mm) | 11 1/8" (283mm) | 37 3/4" (959mm) |
| (914mm)        | 4 1/4" (108mm) | 27" (686mm)     | 11 1/8" (283mm) | 38 1/8" (969mm) |
|                | 5 1/4" (133mm) | 27 3/8" (695mm) | 11 3/8" (289mm) | 38 5/8" (981mm) |
|                | 6 1/4" (159mm) | 27 5/8" (702mm) | 11 1/2" (292mm) | 39 1/8" (994mm) |

\*Add suffix -V (vented) or -S (solid) to catalog number.  
EXAMPLE: 234-1241-12-V

## 30° Vertical Elbow Outside [30] & Inside [31]

### OUTSIDE (30)

### INSIDE (31)

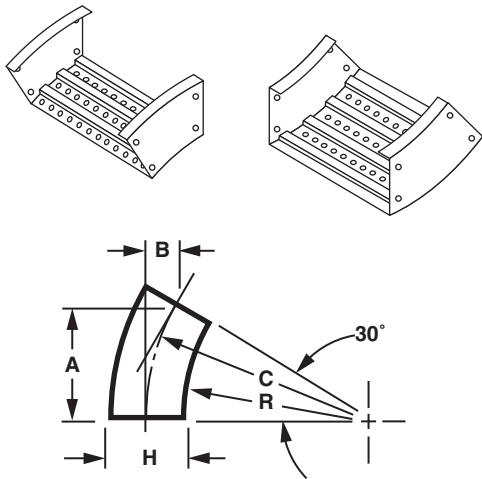

### CSA Compliance for CSA Systems

| Radius - R     | "H" Dim.       | "A" Dim.        | "B" Dim.       | "C" Dim.        |
|----------------|----------------|-----------------|----------------|-----------------|
| 12"<br>(305mm) | 3 1/2" (89mm)  | 6 7/8" (175mm)  | 1 7/8" (48mm)  | 13 3/4" (349mm) |
|                | 4 1/4" (108mm) | 7 1/8" (181mm)  | 1 7/8" (48mm)  | 14 1/8" (359mm) |
|                | 5 1/4" (133mm) | 7 3/8" (187mm)  | 2" (51mm)      | 14 5/8" (372mm) |
| 24"<br>(610mm) | 6 1/4" (159mm) | 7 5/8" (194mm)  | 2" (51mm)      | 15 1/8" (384mm) |
|                | 3 1/2" (89mm)  | 12 7/8" (327mm) | 3 1/2" (89mm)  | 25 3/4" (654mm) |
|                | 4 1/4" (108mm) | 13 1/8" (334mm) | 3 1/2" (89mm)  | 26 1/8" (664mm) |
| 36"<br>(914mm) | 5 1/4" (133mm) | 13 3/8" (340mm) | 3 5/8" (92mm)  | 26 5/8" (676mm) |
|                | 6 1/4" (159mm) | 13 5/8" (346mm) | 3 5/8" (92mm)  | 27 1/8" (689mm) |
|                | 3 1/2" (89mm)  | 18 7/8" (480mm) | 5 1/8" (130mm) | 37 3/4" (959mm) |
| (914mm)        | 4 1/4" (108mm) | 19 3/8" (486mm) | 5 1/8" (130mm) | 38 1/8" (969mm) |
|                | 5 1/4" (133mm) | 19 3/8" (492mm) | 5 1/4" (133mm) | 38 5/8" (981mm) |
|                | 6 1/4" (159mm) | 19 5/8" (499mm) | 5 1/4" (133mm) | 39 1/8" (994mm) |

\*Add suffix -V (vented) or -S (solid) to catalog number.  
EXAMPLE: 234-1231-12-V

**Note:** When small or in-between angles are needed, use AB-Cope's Adjustable Connectors.

### Ordering Information:

See Page 168  
for Electrical  
Grounding Chart

Prefix No.

**[F] [D] [M] - [W] [Bp] - [R] - [B]**

Flange Width (2=1 3/16", 4=1-1/4")

Load Depth (3", 4", 5", 6")

Material Finish (2=Mill-Galv, 3=HDAF, 4=Alum., U=304SS)

Bottom (S=Solid, V=Vented)

Radius (12", 24", 36")

Basic Part (40, 41, 30, 31)

Width (06", 09", 12", 18", 24", 30", 36")

## 90° Vertical Cable Support Elbow [SR]

"J" hooks not included.  
Order separately (Cat. No. 75170)

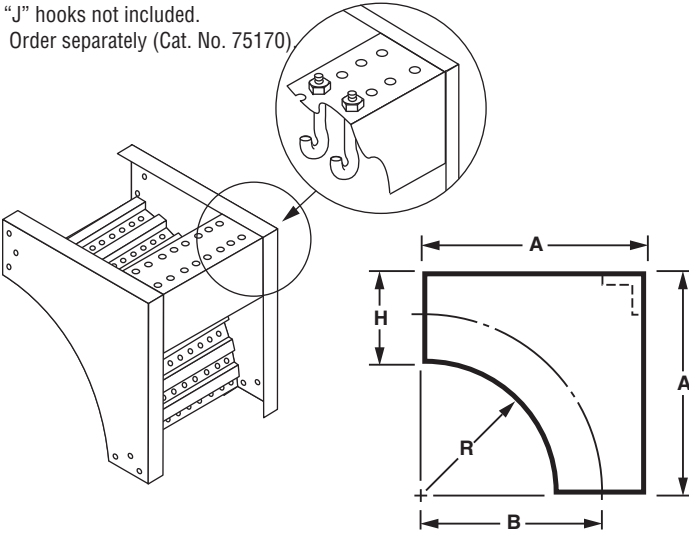

**CSA Compliance for CSA Systems**

| Radius-R       | "H" Dim.       | "A"              |                 | "B"       |           |
|----------------|----------------|------------------|-----------------|-----------|-----------|
|                |                | Dimension        | Dimension       | Dimension | Dimension |
| 12"<br>(305mm) | 3 1/2" (89mm)  | 15 1/2" (394mm)  | 13 3/4" (349mm) |           |           |
|                | 4 1/2" (108mm) | 16 1/4" (413mm)  | 14 1/8" (359mm) |           |           |
|                | 5 1/4" (133mm) | 17 1/4" (438mm)  | 14 5/8" (371mm) |           |           |
| 24"<br>(610mm) | 6 1/4" (159mm) | 18 1/4" (464mm)  | 15 1/8" (384mm) |           |           |
|                | 3 1/2" (89mm)  | 27 1/2" (699mm)  | 25 3/4" (654mm) |           |           |
|                | 4 1/4" (108mm) | 28 1/4" (718mm)  | 26 1/8" (664mm) |           |           |
| 36"<br>(914mm) | 5 1/4" (133mm) | 29 1/4" (743mm)  | 26 5/8" (676mm) |           |           |
|                | 6 1/4" (159mm) | 30 1/4" (768mm)  | 27 1/8" (689mm) |           |           |
|                | 3 1/2" (89mm)  | 39 1/2" (1003mm) | 37 3/4" (959mm) |           |           |
| 36"<br>(914mm) | 4 1/4" (108mm) | 40 1/4" (1022mm) | 38 1/8" (968mm) |           |           |
|                | 5 1/4" (133mm) | 41 1/4" (1048mm) | 38 5/8" (981mm) |           |           |
|                | 6 1/4" (159mm) | 42 1/4" (1073mm) | 39 1/8" (994mm) |           |           |

\*Add suffix -V (vented) or -S (solid) to catalog number  
EXAMPLE: 234-12SR-12-V

## Vertical Tee Down [VT] & Up [OT]

### VERTICAL TEE - DOWN (VT)

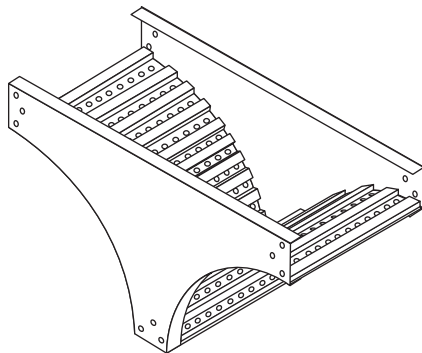

**CSA Compliance for CSA Systems**

| Radius-R       | "H" Dim.       | "A"              |                  | "B"             |           | "C"       |           |
|----------------|----------------|------------------|------------------|-----------------|-----------|-----------|-----------|
|                |                | Dimension        | Dimension        | Dimension       | Dimension | Dimension | Dimension |
| 12"<br>(305mm) | 3 1/2" (89mm)  | 27 1/2" (699mm)  | 15 1/2" (394mm)  | 13 3/4" (349mm) |           |           |           |
|                | 4 1/4" (108mm) | 28 1/4" (718mm)  | 16 1/4" (413mm)  | 14 1/8" (359mm) |           |           |           |
|                | 5 1/4" (133mm) | 29 1/4" (743mm)  | 17 1/4" (438mm)  | 14 5/8" (371mm) |           |           |           |
| 24"<br>(610mm) | 6 1/4" (159mm) | 30 1/4" (768mm)  | 18 1/4" (464mm)  | 15 1/8" (384mm) |           |           |           |
|                | 3 1/2" (89mm)  | 51 1/2" (1308mm) | 27 1/2" (699mm)  | 25 3/4" (654mm) |           |           |           |
|                | 4 1/4" (108mm) | 52 1/4" (1327mm) | 28 1/4" (718mm)  | 26 1/8" (664mm) |           |           |           |
| 36"<br>(914mm) | 5 1/4" (133mm) | 53 1/4" (1353mm) | 29 1/4" (743mm)  | 26 5/8" (676mm) |           |           |           |
|                | 6 1/4" (159mm) | 54 1/4" (1378mm) | 30 1/4" (768mm)  | 27 1/8" (689mm) |           |           |           |
|                | 3 1/2" (89mm)  | 75 1/2" (1918mm) | 39 1/2" (1003mm) | 37 3/4" (959mm) |           |           |           |
| 36"<br>(914mm) | 4 1/4" (108mm) | 76 1/4" (1937mm) | 40 1/4" (1022mm) | 38 1/8" (968mm) |           |           |           |
|                | 5 1/4" (133mm) | 77 1/4" (1962mm) | 41 1/4" (1048mm) | 38 5/8" (981mm) |           |           |           |
|                | 6 1/4" (159mm) | 78 1/4" (1988mm) | 42 1/4" (1073mm) | 39 1/8" (994mm) |           |           |           |

\*Add suffix -V (vented) or -S (solid) to catalog number.  
EXAMPLE: 234-12VT-12-V

### VERTICAL TEE - UP (OT)

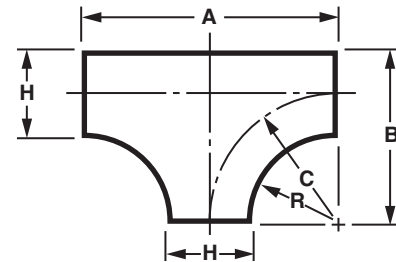
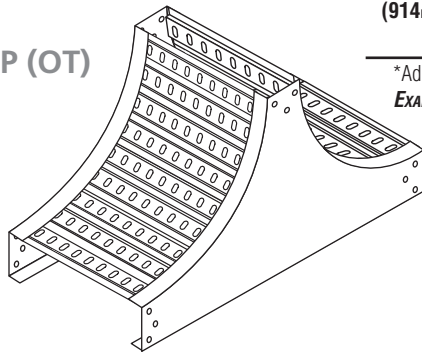

**Note:** When small or in-between angles are needed, use AB-Cope's Adjustable Connectors.

### Ordering Information:

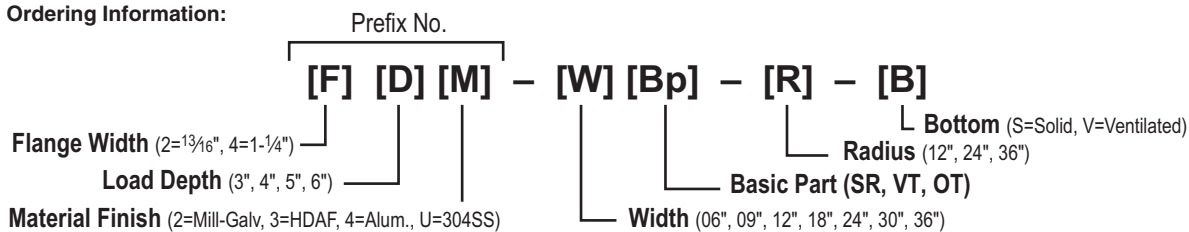

See Page 168  
for Electrical  
Grounding Chart

### Tray Connectors

| Catalog No. |                |                |
|-------------|----------------|----------------|
| Load Depth  | Finish         | Basic No.      |
| 3"          | 2 (Mill Galv.) | -02RC          |
| 4"          | 3 (HDGAF)      | -02CE          |
| 5"          | 4 (Alum.)      | -02CV          |
| 6"          | U (304SS)      | -02CH<br>-02CA |

**EXAMPLE:** 34 -02RC for 3" load depth, aluminum, universal curvilinear connector.

Part Nos. CE, CH, and CV to be bonded if used as equipment grounding conductor.

**Note:** Hole patterns match corresponding tray. 3-hole pattern illustrated.

Heavy Duty, Mid Span Splice Plates available upon request.

### Horizontal Adjustable Connectors [CH]

**Note:** Sold in pairs – inner & outer

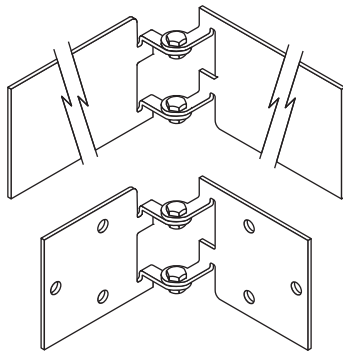

11 Gage Steel, 0.125" Aluminum  
3/8"-16 spline bolts & flange nuts furnished.

**Note:** Bonding Jumpers are required and are sold separately.

### Universal Curvilinear Connector [RC]

**Note:** Sold in pairs

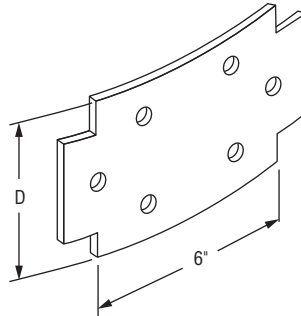

11 Gage Steel, 0.125" Aluminum  
3/8"-16 spline bolts & flange nuts furnished.

### Vertical Adjustable Connectors [CV]

**Note:** Sold in pairs

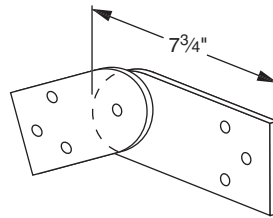

11 Gage Steel, 0.125" Aluminum  
3/8"-16 spline bolts & flange nuts furnished.

**Note:** Bonding Jumpers are required and are sold separately.

### Expansion Connector [CE]

**Note:** Sold in pairs

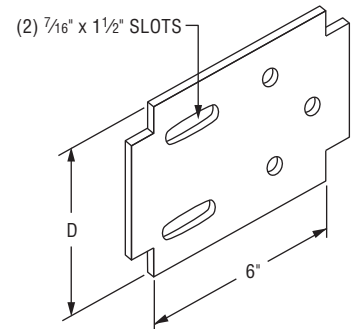

11 Gage Steel, 0.125" Aluminum  
3/8"-16 cap screws & Nylok nuts furnished and  
3/8"-16 spline bolts & flange nuts furnished.

**Note:** Bonding Jumpers are required and are sold separately.

### 90° Angle Connector [CA]

**Note:** Sold in pairs

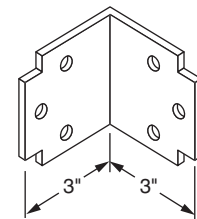

11 Gage Steel, 0.125" Aluminum  
3/8"-16 spline bolts and flange nuts furnished.

### Reducing Connector [CO]

**Note:** Not sold in pairs

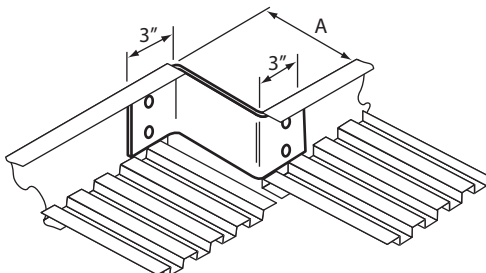

L.H. OFFSET  
REDUCTION



STRAIGHT  
REDUCTION



R.H. OFFSET  
REDUCTION

12 Gage Steel, 0.125" Aluminum. 3/8"-16 spline bolts and flange nuts furnished.  
For offset reductions – use 1 of above with standard connector plate.  
For straight reductions– use 2 (of 1/2 reduction dimension).

### Catalog Number

| Load Depth | Finish         | Basic No. | "A" Dimension |         |
|------------|----------------|-----------|---------------|---------|
| 3"         | 2 (Mill Galv.) | -30CO     | 30"           | (762mm) |
| 4"         | 3 (HDGAF)      | -27CO     | 27"           | (686mm) |
| 5"         | 4 (Alum.)      | -24CO     | 24"           | (610mm) |
| 6"         | U (304SS)      | -21CO     | 21"           | (533mm) |
|            |                | -18CO     | 18"           | (457mm) |
|            |                | -15CO     | 15"           | (381mm) |
|            |                | -13CO     | 13 1/2"       | (343mm) |
|            |                | -12CO     | 12"           | (305mm) |
|            |                | -10CO     | 10 1/2"       | (267mm) |
|            |                | -09CO     | 9"            | (229mm) |
|            |                | -07CO     | 7 1/2"        | (191mm) |
|            |                | -06CO     | 6"            | (152mm) |
|            |                | -04CO     | 4 1/2"        | (114mm) |
|            |                | -03CO     | 3"            | (76mm)  |
|            |                | -01CO     | 1 1/2"        | (38mm)  |

**EXAMPLE:** 34-03CO for 3" load depth, aluminum, 3" Reducer Connector.  
Typical Use: 9" to 6", or use 2 for 12" to 6", etc.

### MATERIAL/FINISH

Electrogalvanized finish standard. Other finishes available; consult factory.

\*Use following suffix when applicable - use only where indicated.

**EG**..... Electrogalvanized carbon steel only

**-SS**..... 302/304 Stainless Steel

**-SS316**.. 316 Stainless Steel (check factory for availability)

*Example:* E-142- 3/8 x 1 1/2 SS, 3/8 x 1 1/2 hex head bolt, 304 stainless steel

### Connector Hardware

(Case-hardened steel electrogalvanized)

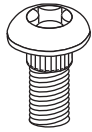

**Part No. 5003-1**  
3/8"-16 x 1" spline bolt



**Part No. 5009-1**  
3/8"-16 hex-flanged nut with serrated washer face.

### Cover Screw [E-150-S]

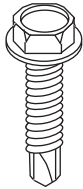

**E-150-S**  
Hex Head Lag Bolt



|                   |     |       |
|-------------------|-----|-------|
| <b>Screw Size</b> | 3/8 | 1/2   |
| <b>Drill Size</b> | 1/4 | 11/32 |

See Price Sheet for Length.

### Continuous Threaded Rod [H-104]

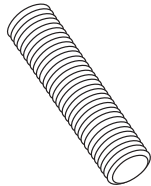

| Size | NATIONAL COARSE THREAD |              |                  |
|------|------------------------|--------------|------------------|
|      | Threads per inch       | lbs./100 ft. | Design Load lbs. |
| 1/4  | 20                     | 12.5         | 150              |
| 3/8  | 16                     | 29           | 610              |
| 1/2  | 13                     | 53.5         | 1130             |
| 5/8  | 11                     | 85           | 1810             |
| 3/4  | 10                     | 123          | 2710             |
| 7/8  | 9                      | 130          | 3770             |
| 1    | 8                      | 214          | 4960             |

### Rod Coupler [H-119]

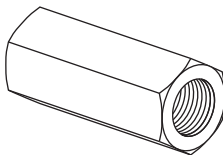

| Prod. #    | Rod Size | A     | Wt./C lbs. |
|------------|----------|-------|------------|
| H-119-1/4  | 1/4      | 1-3/4 | 9          |
| H-119-5/16 | 5/16     | 1-3/4 | 7          |
| H-119-3/8  | 3/8      | 1-3/4 | 10         |
| H-119-1/2  | 1/2      | 1-3/4 | 18         |
| H-119-5/8  | 5/8      | 2-1/8 | 23         |
| H-119-3/4  | 3/4      | 2-1/4 | 21         |
| H-119-7/8  | 7/8      | 2-1/2 | 55         |
| H-119-1    | 1        | 2-3/4 | 68         |

### Hex Nuts [E-145]



**E-145**  
Standard Hex Nut

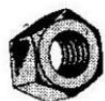

| Size | Wt./C lbs. |
|------|------------|
| 1/4  | .72        |
| 3/8  | 1.06       |
| 1/2  | 2.78       |
| 5/8  | 6.92       |
| 3/4  | 12.70      |
| 7/8  | 19.00      |
| 1    | 26.00      |

### Square Nuts [E-146 ]

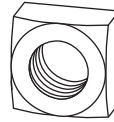

**E-146**  
Standard Square Nut



| Size | Wt./C lbs. |
|------|------------|
| 1/4  | .93        |
| 5/16 | 1.60       |
| 3/8  | 2.65       |
| 1/2  | 5.83       |
| 5/8  | 10.80      |

### Flat Washers [E-147]

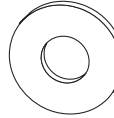

**E-147**  
Flat Steel Washer



| Size | Wt./C lbs. |
|------|------------|
| 1/4  | .67        |
| 5/16 | 1.11       |
| 3/8  | 1.49       |
| 1/2  | 3.85       |
| 5/8  | 7.69       |
| 7/8  | 15.40      |

### Split-Lock Washers [E-148]

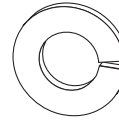

**E-148**  
Lock Washer



| Size | Wt./C lbs. |
|------|------------|
| 1/4  | .26        |
| 5/16 | .39        |
| 3/8  | .50        |
| 1/2  | 1.09       |
| 5/8  | 2.57       |

### Fender Washers [EF-147]

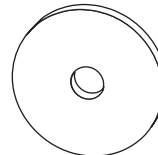

**EF-147**  
Fender Washer

| Size | A     | B    | Wt./C lbs. |
|------|-------|------|------------|
| 1/4  | 1-1/4 | 5/16 | 3.1        |
| 3/8  | 1-1/2 | 7/16 | 2.9        |
| 1/2  | 2     | 9/16 | 5.0        |

### Hex Head Cap Screw / Round Head, Slotted Cap Screw [E-142]

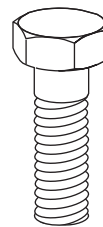

**E-142**  
Hex Head Cap Screw



| Size        | Wt./C lbs. |
|-------------|------------|
| 1/4 x 1     | 1.74       |
| 1/4 x 1-1/2 | 2.43       |
| 3/8 x 1     | 4.17       |
| 3/8 x 1-1/2 | 5.64       |
| 1/2 x 15/16 | 8.94       |
| 1/2 x 1-1/2 | 10.00      |

See Price Sheet For Additional Sizes

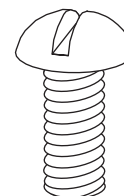

Catalog No. E-141

**COVERS** for straight sections shown. Standard fitting covers are flat solid type (NF). Aluminum covers are fabricated from 0.040" aluminum AA-3150-H14; steel covers are fabricated from 20 gage ASTM A-653-G90 CQ, mill-galvanized steel.

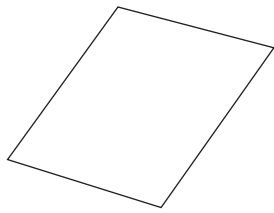

**NF** – Flat Solid

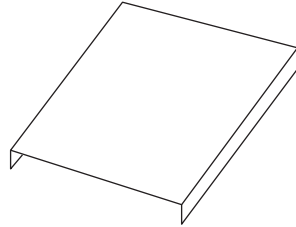

**FS** – Flat Solid  
w/3/8" Flange

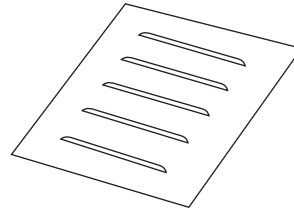

**NL** – Flat Louvered

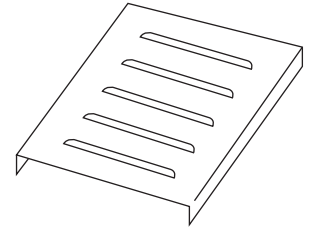

**FL** – Louvered  
w/3/8" Flange

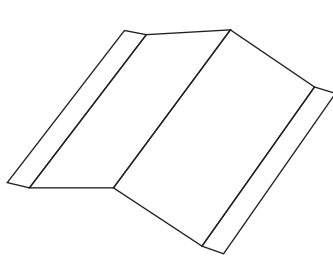

**PS** – Peaked Solid  
(suffix height)

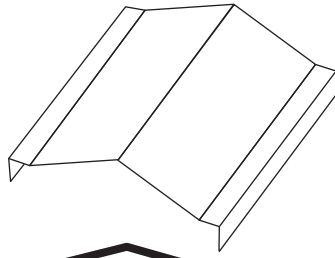

**PF** – Peaked Flanged Solid  
(suffix height)

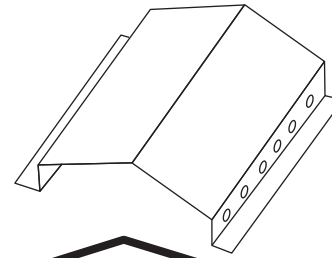

**PV** – Peaked Hat Vent  
**PH** – Peaked Hat Solid  
(suffix height)

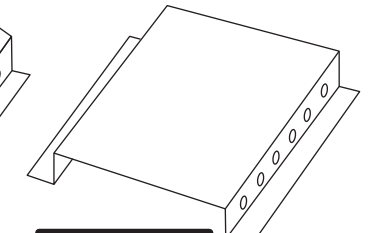

**HS** – Hat Solid  
**HV** – Hat Vent  
(suffix height)

**Note:** Use EM-CC Cover Screws (see pg. 158) to attach PH, PV, HS & HV covers.  
**HDGAF** straights only available in 6' sections.

### Cover Catalog Number – Straight Sections

| Type    | Finish         | Basic No. (Width)   | Length | Height* |
|---------|----------------|---------------------|--------|---------|
| HS, HV, | 2 - Mill Galv. | -06SL = 6" (152mm)  | -12'   | -2"     |
| FL, FS, | 3 - HDGAF      | -09SL = 9" (229mm)  | -10'   |         |
| NF, NL, | 4 - Alum.      | -12SL = 12" (305mm) | -06'   |         |
| PS, PF, | U - 304SS      | -18SL = 18" (457mm) |        |         |
| PH, PV  |                | -24SL = 24" (610mm) |        |         |
|         |                | -30SL = 30" (762mm) |        |         |
|         |                | -36SL = 36" (914mm) |        |         |

\* peak and hat only, 2" height standard. Consult factory for other heights.

**EXAMPLE:** NL2-09SL-12 is a flat louvered mill-galv. steel cover for a 9" wide mill galvanized TROF 12' long.

### Cover Catalog Number – Fittings

| Type | Load Depth | Finish         | Width/Basic No. | Radius |
|------|------------|----------------|-----------------|--------|
| NF   | 3          | 2 - Mill Galv. | -06 XX**        | 12"    |
| FS   | 4          | 3 - HDGAF      | -09 XX**        | 24"    |
|      | 5          | 4 - Alum.      | -12 XX**        | 36"    |
|      | 6          | U - 304SS      | -18 XX**        |        |
|      |            |                | -24 XX**        |        |
|      |            |                | -30 XX**        |        |
|      |            |                | -36 XX**        |        |

\*Load depth for outside riser or vertical tee only.

\*\*XX from fitting selection page 141.

### Joint Plate

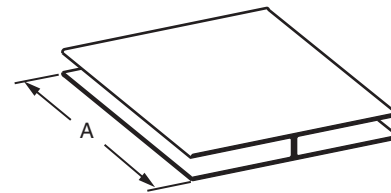

Joint plate is black PVC and is offered in 10' lengths to be field cut to desired length, or in precut lengths for specified covers.

JP-120 is joint plate in 10' lengths.

Joint plate for specified covers is specified as follows.

| Tray Width          | Flange Type        |
|---------------------|--------------------|
| JP-06 = 6" (152mm)  |                    |
| JP-09 = 9" (229mm)  | -2 = 13/16" Flange |
| JP-12 = 12" (305mm) | -4 = 1 1/4" Flange |
| JP-18 = 18" (457mm) | -7 = 2" Flange     |
| JP-24 = 24" (610mm) |                    |
| JP-30 = 30" (762mm) |                    |
| JP-36 = 36" (914mm) |                    |

**EXAMPLE:** JP-06-2 is a joint plate for 6" wide tray with a 13/16" flange.

# TROF CABLE TRAY SYSTEM

## COVER ACCESSORIES

### Single Side Connector [01CC]



Furnished with 1/4"-28 stainless steel cone point machine screw.

For use with any width tray.

Not sold in pairs.

Suggested spacing:  
Indoor Use Only;  
4 per 12' section

#### Catalog Number [Basic No -01CC]

| Flange                               | Load Depth | Finish         |
|--------------------------------------|------------|----------------|
| 2 - 1 <sup>3</sup> / <sub>16</sub> " | 3          | 2 - Mill Galv. |
| 4 - 1 <sup>1</sup> / <sub>4</sub> "  | 4          | 3 - HDGAF      |
| 5 - 1 <sup>1</sup> / <sub>2</sub> "  | 5          | 4 - Alum.      |
| 7 - 2"                               | 6          | U - 304SS      |

**EXAMPLE:** 234-01CC for 3" load depth, aluminum single side connector.

### Peak Vent Cover Connector [VC]

Note: For PV Covers

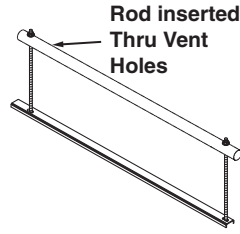

#### Catalog Number

| Flange                             | Load Depth | Finish       | Width | Type |
|------------------------------------|------------|--------------|-------|------|
| 2=1 <sup>3</sup> / <sub>16</sub> " | 3          | 6=Mill Galv. | -06   | VC   |
| 4=1 <sup>1</sup> / <sub>4</sub> "  | 4          | 7=HDGAF      | -09   |      |
| 5=1 <sup>1</sup> / <sub>2</sub> "  | 5          | 8=Alum.      | -12   |      |
| 6=1 <sup>3</sup> / <sub>4</sub> "  | 6          | T=304SS      | -18   |      |
|                                    |            |              | -24   |      |
|                                    |            |              | -30   |      |
|                                    |            |              | -36   |      |

**EXAMPLE:** 238-12VC for 3" load depth, 1<sup>3</sup>/<sub>16</sub>" flange, aluminum, 12" wide, Peak Vented Cover Connector

### Double Clamp Connector [(W) DC]

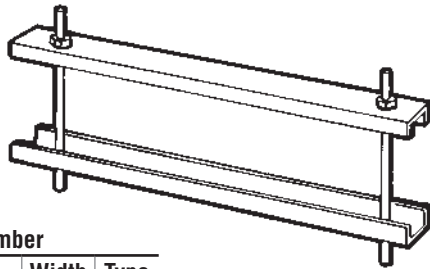

#### Catalog Number

| Load Depth | Finish         | Width | Type |
|------------|----------------|-------|------|
| 3          | 2 - Mill Galv. | -06   | DC   |
| 4          | 3 - HDGAF      | -09   |      |
| 5          | 4 - Alum.      | -12   |      |
| 6          | U - 304SS      | -18   |      |
|            |                | -24   |      |
|            |                | -30   |      |
|            |                | -36   |      |

**EXAMPLE:** 34-12DC for 3" load depth, 1<sup>3</sup>/<sub>16</sub>" flange, aluminum, Double Clamp Connector.

For all covers except hat & peak type. Furnished with:  
(2) 1/4"-20 all-thread rods  
(4) hex nuts, flat washers and lock washers

Suggested spacing:

Indoor: 2 per 12'  
Outdoor: 3 per 12'  
High Wind: 5 per 12'

### Cover Connector [CC]

Note: For all covers except hat & peak type

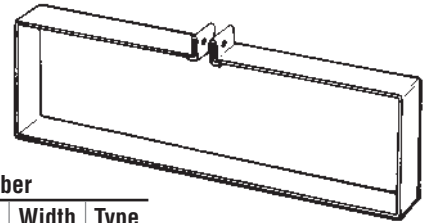

#### Catalog Number

| Load Depth | Finish         | Width | Type |
|------------|----------------|-------|------|
| 3          | 2 - Mill Galv. | -06   | CC   |
| 4          | 3 - HDGAF      | -09   |      |
| 5          | 4 - Alum.      | -12   |      |
| 6          | U - 304SS      | -18   |      |
|            |                | -24   |      |
|            |                | -30   |      |
|            |                | -36   |      |

**EXAMPLE:** 34-12CC for 1<sup>3</sup>/<sub>16</sub>" flange, 3" load depth, aluminum, 12" wide connector.

### Peak Cover Connector [PC]

Note: For PS & PF Cover

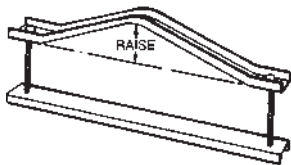

#### Catalog Number

| Load Depth | Finish         | Width | Type | Raise (in)* |
|------------|----------------|-------|------|-------------|
| 3          | 2 - Mill Galv. | -06   | PC   | -2          |
| 4          | 3 - HDGAF      | -09   |      |             |
| 5          | 4 - Alum.      | -12   |      |             |
| 6          | U - 304SS      | -18   |      |             |
|            |                | -24   |      |             |
|            |                | -30   |      |             |
|            |                | -36   |      |             |

\*2" standard raise. Consult factory for other peak heights.

**EXAMPLE:** 34-12-VC-3 for 3" load depth, aluminum, 12" wide, Peak Cover Connector (vented cover) with 2" peak.

### Elevated Cover Connectors [EM-CC]

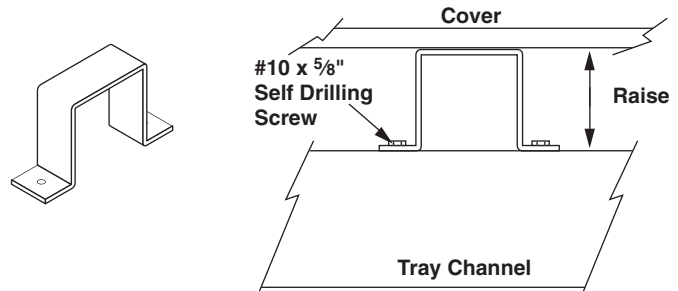

#### Catalog Number

| Finish         | Type  | Height*        |
|----------------|-------|----------------|
| 2 - Mill Galv. | EM-CC | - Raise* (in.) |
| 3 - HDGAF      |       |                |
| 4 - Alum.      |       |                |
| U - 304SS      |       |                |

\*1", 2" or 3" standard.

**EXAMPLE:** 3-EM-CC-2 for hot dipped galvanized, Elevated Cover Connector with a 2" raise.

Includes:

(3) #10 x 5/8" Self drilling screws.

Suggested spacing:

Indoor: 3/Side (6 tot.) per 12';

### Drop Out [DO]

14 Gage Steel, .080" Aluminum  
**NOTE:** (2) #10 x 5/8" self tapping screws furnished.

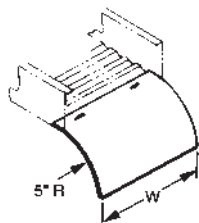

| Catalog Number |                     |
|----------------|---------------------|
| Basic Finish   | Width               |
| 2 (Mill Galv.) | -06DO = 6" (152mm)  |
| 3 (HDGAF)      | -09DO = 9" (229mm)  |
| 4 (Alum.)      | -12DO = 12" (305mm) |
| U (304SS)      | -18DO = 18" (457mm) |
|                | -24DO = 24" (610mm) |
|                | -30DO = 30" (762mm) |
|                | -36DO = 36" (914mm) |

**EXAMPLE:** 4-12DO for aluminum, 12" wide, Drop Out.

### Blind End [BE]

22 Gage Steel, .040" Aluminum  
**Note:** 3/8"-16 spline bolts and flange nuts furnished.

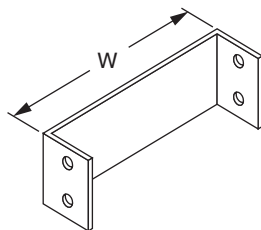

| Catalog Number |                |                     |
|----------------|----------------|---------------------|
| Load Depth     | Finish         | Width               |
| 3              | 2 (Mill Galv.) | -06BE = 6" (152mm)  |
| 4              | 3 (HDGAF)      | -09BE = 9" (229mm)  |
| 5              | 4 (Alum.)      | -12BE = 12" (305mm) |
| 6              | U (304SS)      | -18BE = 18" (457mm) |
|                |                | -24BE = 24" (610mm) |
|                |                | -30BE = 30" (762mm) |
|                |                | -36BE = 36" (914mm) |

**EXAMPLE:** 34-12BE for 3" load depth, aluminum, 12" wide Blind End.

### Cable Tray Ground Clamp [9156]

Extruded Alum. with Electro-Galvanized Steel Hex Head Screws.  
 Capacity: #6 AWG to 250 kcmil

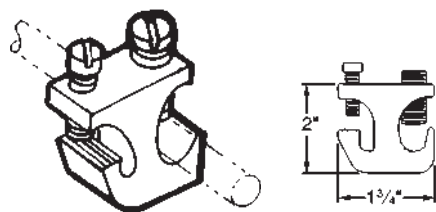

### Box Connector [CB]

14 Gage Steel  
 .080" Aluminum  
**NOTE:** 1/4"-20 carriage bolts, flat washers, hex nuts furnished.

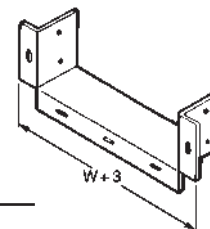

| Catalog Number |                  |                     |
|----------------|------------------|---------------------|
| Load Depth     | Finish           | Width               |
| 3              | 2 - (Mill Galv.) | -06CB = 6" (152mm)  |
| 4              | 3 - (HDGAF)      | -09CB = 9" (229mm)  |
| 5              | 4 - (Alum.)      | -12CB = 12" (305mm) |
| 6              | U - (304SS)      | -18CB = 18" (457mm) |
|                |                  | -24CB = 24" (610mm) |
|                |                  | -30CB = 30" (762mm) |
|                |                  | -36CB = 36" (914mm) |

**EXAMPLE:** 34-12CB for 3" load depth, aluminum, 12" wide, Box Connector.

### Bonding Jumper [CBJ]

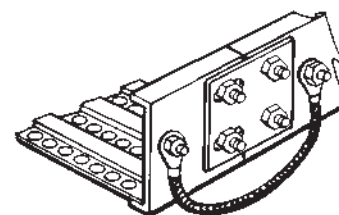

| Catalog No. | Dimensional Data                            | Amperes as Equipment Ground |
|-------------|---|-----------------------------|
| CBJ-C       | AWG 1/0 copper wire<br>15 1/2" long overall | 800 amperes                 |
| CBJ-4C      | AWG 4/0 copper wire<br>15 1/2" long overall | 1,600 amperes               |
| CBJ-250C    | 250 MCM copper wire<br>15 1/2" long overall | 2,000 amperes               |

**NOTE:**  
 No hardware supplied  
 For hardware kit add -HDW:  
 Ex: CBJ-C-HDW includes  
 2ea CBJ-C  
 4ea 5003-1  
 4ea 5009-1

### Ground Cable Retainer Clamp

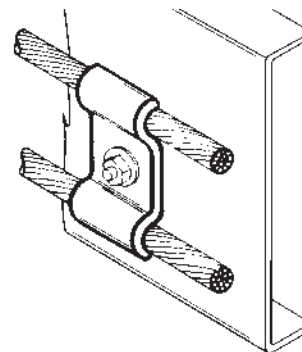

| Catalog No. | Capacity    | Metal & Finish      | Dimensions         |
|-------------|-------------|---------------------|--------------------|
| 9056-EP     | 1/0 2/0 3/0 | Electro-Galv. Steel | 1" w x 2" long     |
| 9057-EP     | 4/0 250 MCM |                     | 1" w x 2 3/8" long |
| 9056-SS     | 1/0 2/0 3/0 | Stainless Steel     | 1" w x 2" long     |
| 9057-SS     | 4/0 250 MCM |                     | 1" w x 2 3/8" long |

# TROF CABLE TRAY SYSTEM

## ACCESSORIES

### Conduit Clamp Bracket



| Catalog No. | Size Rigid   | Size EMT |
|-------------|--------------|----------|
| CCB-050     | 3/8" to 1/2" | 1/2"     |
| CCB-075     | 3/4"         | 3/4"     |
| CCB-100     | 1"           | 1"       |
| CCB-125     | -            | 1 1/4"   |
| CCB-150     | 1 1/4"       | 1 1/2"   |
| CCB-200     | 2"           | 2"       |

### Conduit-to-Cable Tray Clamp - Swivel Type

Malleable iron hub and steel "U" bolt.  
For connecting and grounding rigid conduit to tray at any angle within 90° arc.  
U.L. listed as a grounding means.

| Catalog No. | Size      | Std. Pkg. |
|-------------|-----------|-----------|
| TB6209      | 1/2"-3/4" | 10        |
| TB6211      | 1"-1 1/4" | 10        |
| TB6214      | 1 1/2"-2" | 5         |
| TB6216      | 2 1/2"-3" | 5         |
| TB6218      | 3 1/2"-4" | 2         |

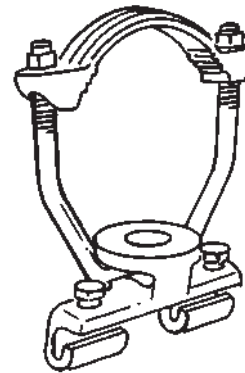

### Wall Penetrating Sleeve Assembly [SS89042W\*]

Note: W = Tray Width  
\* = Fitting 3-Digit Prefix

**Note:** Standard penetration sleeves are manufactured from mill galvanized steel. Aluminum sleeves are available upon request.

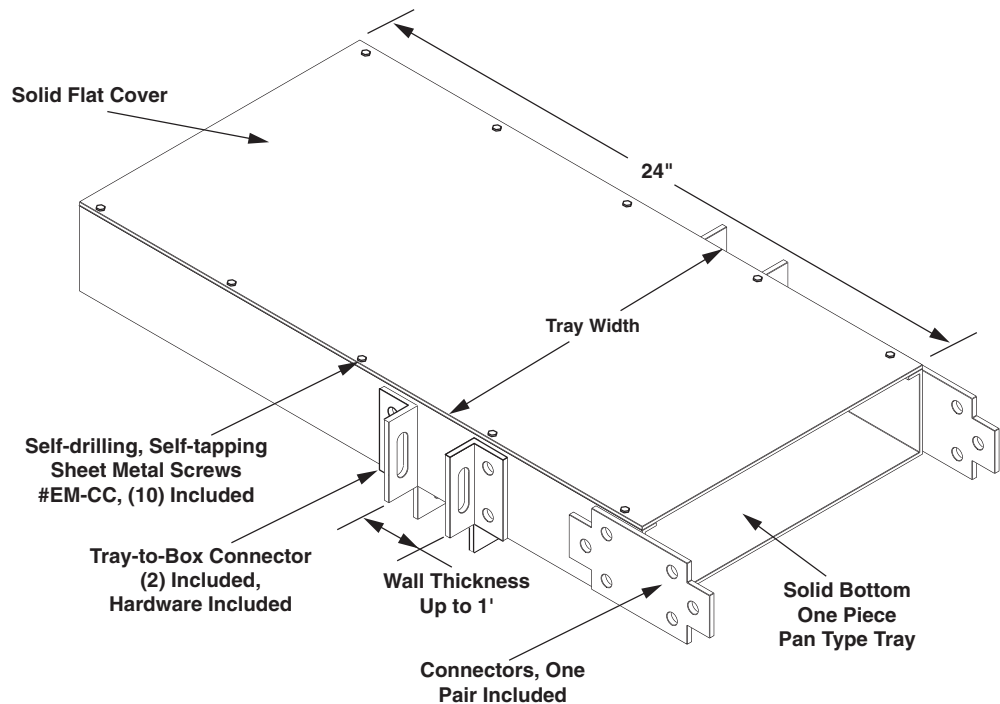

### Universal Aluminum Barrier Strip - Straight Section [SB]

| Catalog Number |           |                    |
|----------------|-----------|--------------------|
| Load Depth     | Finish    | Basic No. - Length |
| 3              | A (Alum.) | -01SB-12           |
| 4              |           |                    |
| 5              |           |                    |
| 6              |           |                    |

**EXAMPLE:** 3A-01SB-12 for 3" load depth, aluminum straight barrier, 12' long.

Furnished with 8 self tapping screws.

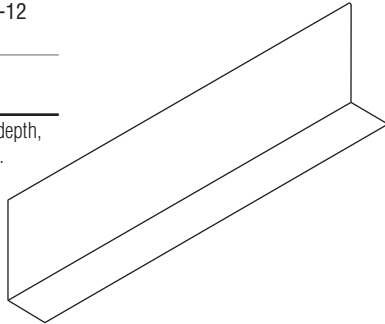

### Barrier Strip - Straight Section [SB]

#### Catalog Number

| Load Depth | Finish         | Basic No. - Length |
|------------|----------------|--------------------|
| 3          | 2 (Mill Galv.) | -01SB-12           |
| 4          | 3 (HDGAF)      |                    |
| 5          | 4 (Alum.) *    |                    |
| 6          | U (304 SS)     |                    |

**EXAMPLE:** 34-01SB-12 for 3" load depth, aluminum straight barrier, 12' long.

\* Long lead time item - See Universal aluminum barrier strip to the left

Furnished with 8 self tapping screws.

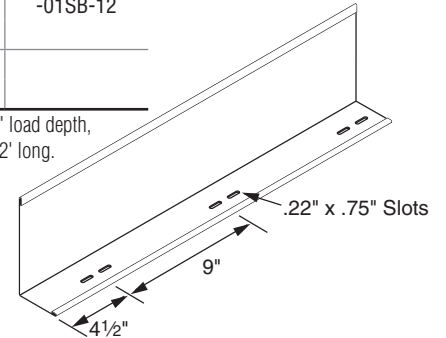

### Barrier Strip - Horizontal Fitting [FB]

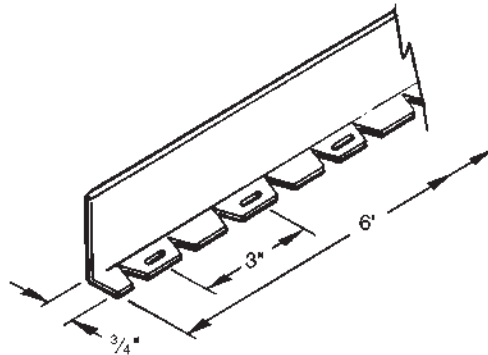

#### Catalog Number

| Load Depth | Finish         | Basic No. - Length |
|------------|----------------|--------------------|
| 3          | 2 (Mill Galv.) | -01FB-06           |
| 4          | 3 (HDGAF)      |                    |
| 5          | 4 (Alum.)      |                    |
| 6          | U (304 SS)     |                    |

**EXAMPLE:** 34-01FB-06 for 3" load depth, aluminum fitting barrier, 6' long.

Furnished with 4 self tapping screws.

### Barrier Strip Vertical Elbow Outside [OB] & Inside [IB]

(OB Vert. Elbow outside shown).

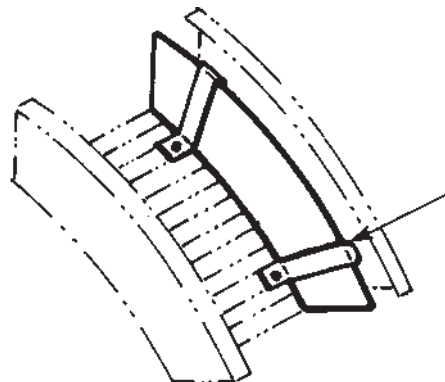

Furnished with sufficient clamp assemblies for installation. Additional clamp assemblies may be ordered separately.

#### Catalog Number

| Load Depth | Finish         | Bend (deg.) | Basic No.    | Radius      |
|------------|----------------|-------------|--------------|-------------|
| 3          | 2 (Mill Galv.) | 90°         | OB = Outside | 12" (305mm) |
| 4          | 3 (HDGAF)      | 60°         | IB = Inside  | 24" (610mm) |
| 5          | 4 (Alum.)      | 45°         |              | 36" (914mm) |
| 6          | U (304 SS)     | 30°         |              |             |

**EXAMPLE:** 34-90OB-12 for 3" load depth, aluminum 90° outside vertical barrier with 12" radius.

### Nylon Barrier Splice & Protector [BSP-L]

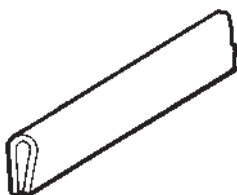

| Catalog Number |                       |
|----------------|-----------------------|
| Prefix         | Length (L)            |
|                | -5 (5" Splice)        |
| BSP            | -144 (144' Protector) |
|                | -1200 (100' Roll)     |

**EXAMPLE:** BSP-1200 for 100' roll

### Cover Screw

Part No. EM-CC (electro galv. steel)  
Part No. EM-CC-SS (stainless steel)

No. 10 x 5/8" long, self drilling-self tapping hex head plated steel screw.

Suggested spacing:  
Indoor: 8 per 12';  
Outdoor: 10 per 12'

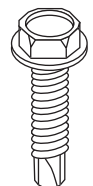

## ACCESSORIES

### Hold-Down Clamp & Expansion Guide

(For expansion guide clamp, add suffix "EX" to catalog number.)

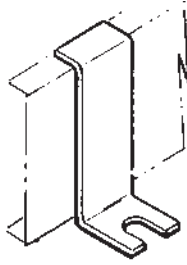

| Catalog Number |                            |
|----------------|----------------------------|
| Load Depth     | Basic No.                  |
| 3              | -9039 (Aluminum)           |
| 4              | -9040 (ElectroGalv. Steel) |
| 5              | -9041 (HDGAF)              |
| 6              | -9042 (316SS)              |

**EXAMPLE:** 3-9039-EX for 3" load depth, expansion guide.  
 Hardware purchased separately to suit support system.  
 Complete Kit add "-HDW" to Part No. Above  
 Hardware Kit List:  
 (2) Hold-Down Clamps  
 (2) 1/2" - 13 x 1 1/4" Cap Screw  
 (2) 1/2" Flat Washer  
 (2) Clamping Nut (Strut Nut)

### Isolation Pad [PVC-PAD]

The Isolation pad provides protection from galvanic corrosion when Aluminum tray is mounted on steel supports.

The PVC-PAD is a 2"x3" plain isolation pad with no hole.

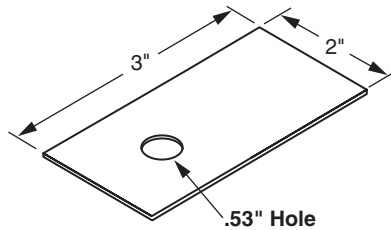

**Note:** For use with the 9039 series of Hold-Down Clamp & Expansion Guide.  
 Hardware purchased separately

### Nylon Dropout Grommet [DOG-1]

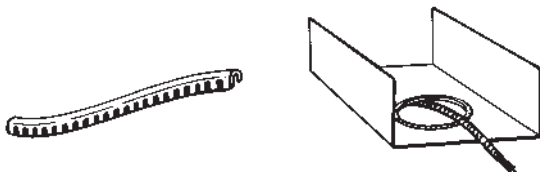

Use at cable dropouts, or thru vent holes.  
 Furnished in 12' lengths. Cut to length in field.

### Barrier Strip Clamp [50172] (optional)

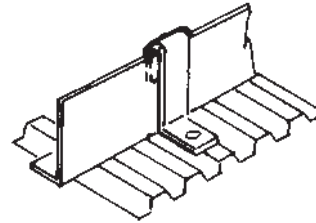

No. 10 bolt, nut, washer and lock washer furnished.

| Catalog Number |                |              |
|----------------|----------------|--------------|
| Load Depth     | Finish         | Basic Number |
| 3              | 2 (Mill Galv.) | -50172       |
| 4              | 3 (HDGAF)      |              |
| 5              | 4 (Alum.)      |              |
| 6              | U (304 SS)     |              |

**EXAMPLE:** 34-5072 for 3" load depth, aluminum clamp.

### Seismic Hold-Down [9132]

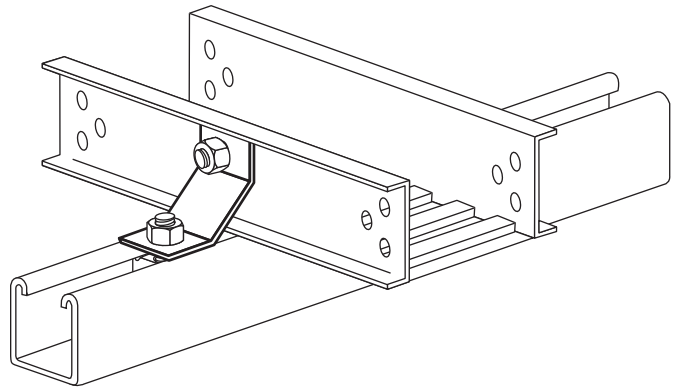

| Catalog No. | Material        |
|-------------|-----------------|
| 9132        | Mill Galvanized |
| 9133        | Stainless Steel |

Hardware purchased separately to suit support system.

**Note:** For seismic applications or other bolted connections is preferred.

### Gusset-Type Supports

For use with all types of AB-Cope Ladder and Trof systems. Finish is electro-galvanized. Order hardware separately.

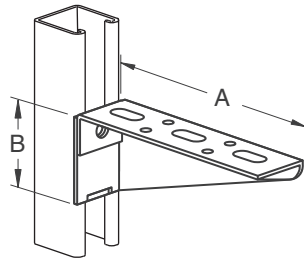

| Catalog No. | Ladder Width | Dimension |                                   | Uniform-Load Rating |
|-------------|--------------|-----------|-----------------------------------|---------------------|
|             |              | A         | B                                 |                     |
| PS 838R-6   | -            | 6"        | 1 <sup>5</sup> / <sub>16</sub> "  | 275 lbs.            |
| PS 838R-8   | -            | 8"        | 2 <sup>7</sup> / <sub>16</sub> "  | 275 lbs.            |
| PS 838R-10  | -            | 10"       | 2 <sup>15</sup> / <sub>16</sub> " | 275 lbs.            |
| PS 838R-12  | 6"           | 12"       | 3 <sup>7</sup> / <sub>16</sub> "  | 275 lbs.            |
| PS 838R-16  | 9"           | 16"       | 4 <sup>7</sup> / <sub>16</sub> "  | 275 lbs.            |
| PS 838R-18  | 12"          | 18"       | 4 <sup>15</sup> / <sub>16</sub> " | 275 lbs.            |
| PS 838R-24  | 18"          | 24"       | 6 <sup>7</sup> / <sub>16</sub> "  | 275 lbs.            |
| PS 838R-30  | 24"          | 30"       | 7 <sup>15</sup> / <sub>16</sub> " | 275 lbs.            |

### Channel-Type Supports

For use with all types of AB-Cope Ladder and Trof systems. Finish is electro-galvanized. Order hardware separately.

#### STANDARD DUTY

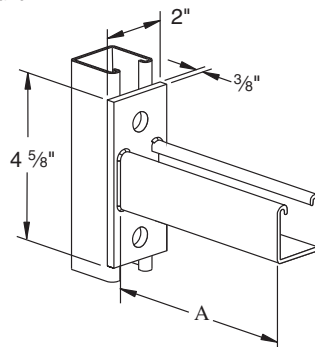

#### Standard Duty for Lighter Loads.

| Catalog No. | Ladder Width | Dimension A | Uniform-Load Rating* |
|-------------|--------------|-------------|----------------------|
| PS 651-6    | -            | 6"          | 1,200 lbs.           |
| PS 651-12   | 6"           | 12"         | 600 lbs.             |
| PS 651-15   | 9"           | 15"         | 480 lbs.             |
| PS 651-18   | 12"          | 18"         | 400 lbs.             |
| PS 651-24   | 18"          | 24"         | 300 lbs.             |
| PS 651-30   | 24"          | 30"         | 240 lbs.             |

\* Mounted on 12 Ga. Channel.

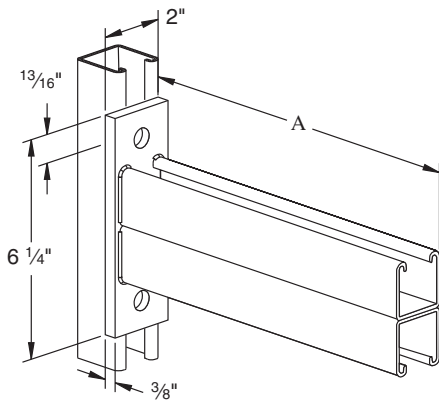

#### HEAVY DUTY

#### Heavy Duty for Heavier Loads

| Catalog No. | Ladder Width | Dimension A | Uniform-Load Rating* |
|-------------|--------------|-------------|----------------------|
| PS 809-12   | 6"           | 12"         | 2,000 lbs.           |
| PS 809-15   | 9"           | 15"         | 1,600 lbs.           |
| PS 809-18   | 12"          | 18"         | 1,300 lbs.           |
| PS 809-24   | 18"          | 24"         | 1,000 lbs.           |
| PS 809-30   | 24"          | 30"         | 800 lbs.             |
| PS 809-36   | 30"          | 36"         | 660 lbs.             |
| PS 809-42   | 36"          | 42"         | 570 lbs.             |

\* Mounted on 12 Ga. Channel.

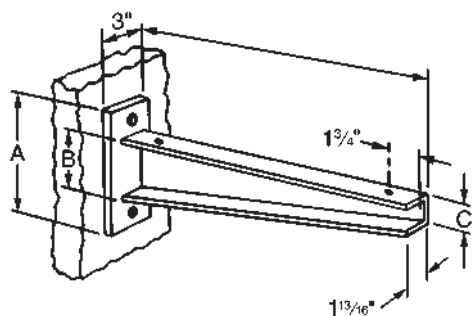

| Catalog No. | Trof Width | Length "L"                       | Dimensions |     |                                 | End-Load Rating* |
|-------------|------------|----------------------------------|------------|-----|---------------------------------|------------------|
|             |            |                                  | "A"        | "B" | "C"                             |                  |
| 9037-12     | 6"         | 12 <sup>1</sup> / <sub>4</sub> " | 10"        | 6"  | 2"                              | 2000 lbs.        |
| 9037-18     | 12"        | 18 <sup>1</sup> / <sub>4</sub> " | 11"        | 7"  | 2 <sup>1</sup> / <sub>2</sub> " | 2000 lbs.        |
| 9037-24     | 18"        | 24 <sup>1</sup> / <sub>4</sub> " | 11"        | 7"  | 2 <sup>1</sup> / <sub>2</sub> " | 1600 lbs.        |
| 9037-30     | 24"        | 30 <sup>1</sup> / <sub>4</sub> " | 12"        | 8"  | 4"                              | 1300 lbs.        |
| 9037-36     | 30"        | 36 <sup>1</sup> / <sub>4</sub> " | 12"        | 8"  | 4"                              | 1100 lbs.        |
| 9037-42     | 36"        | 42 <sup>1</sup> / <sub>4</sub> " | 12"        | 8"  | 4"                              | 900 lbs.         |

\*Uniform load rating is normally twice the end-load rating. Finish is hot-dip galvanized after fabrication. Order hardware separately.

# TROF CABLE TRAY SYSTEM



## TRAY HANGER & SUPPORTS

### Structural Support Bracket

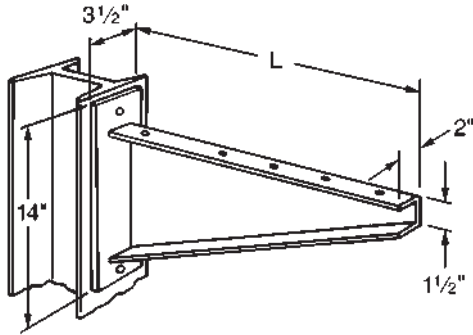

| Catalog No. | Trof Width | Length "L" | End-Load Rating* |
|-------------|------------|------------|------------------|
| 9036-31     | 24"        | 31 1/4"    | 2000 lbs.        |
| 9036-37     | 30"        | 37 1/4"    | 1800 lbs.        |
| 9036-45     | 36"        | 45 1/4"    | 1500 lbs.        |

\*Uniform load rating is normally twice the end-load rating.  
 For use with AB-Cope Trof 24" or wider. May be welded or bolted to building steel.  
 Finish is hot-dip galvanized after fabrication.  
 Order hardware separately.

### Vertical Supports

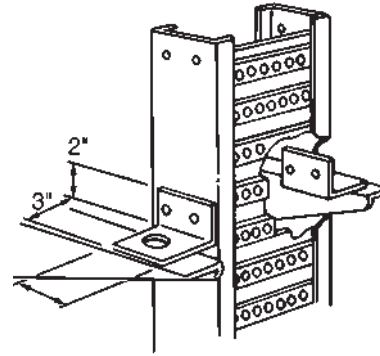

| Cat. No. | For Use With                                |
|----------|---|
| 9045     | 3 1/4" Overall Height Side Members          |
| 9043-37  | 4 1/4" Overall Height Side Members          |
| 9043     | 5 1/4" Overall Height Side Members          |
| 9025-98  | 6 1/4" & 7 1/4" Overall Height Side Members |

Tray Supports can be bolted anywhere along the straight runs. They can be bolted directly onto the coupler plates at splices of straight runs and riser fittings, or they can be bolted at any place in the run by field-drilling side rails. TROF supports are used with either 3/8" or 1/2" hanger rods.  
 Finish is electrogalvanized.

### Single Rod Hanger Support

| Assy. Type | Channel Length* | Channel Finish**        | Catalog Number      |                        | Beam Clamp      |
|------------|-----------------|-------------------------|---------------------|------------------------|-----------------|
|            |                 |                         | Rod Diameter        | Rod Length             |                 |
| P200       | 14"<br>(356mm)  | GV<br>(Pre-Galv)        | 38=3/8"<br>(9.53mm) | 000 - No Rod           | A - Bridgeport  |
|            | 17"<br>(432mm)  |                         | 12=1/2"<br>(12.7mm) | 036 - 36"<br>(914mm)   | B - P2622       |
|            | 20"<br>(508mm)  | HG<br>(Hot Dipped Galv) |                     | 072 - 72"<br>(1828mm)  | O - No Clamp    |
|            | 26"<br>(661mm)  |                         |                     | 120 - 120"<br>(3048mm) | R - Rod Coupler |
|            | 32"<br>(813mm)  |                         |                     | 144 - 144"<br>(3658mm) | S - Special     |
|            | 38"<br>(966mm)  |                         |                     |                        |                 |
|            | 44"<br>(1118mm) |                         |                     |                        |                 |

**EXAMPLE:**  
 P20020GV12036B is a Single 20" pre-galvanized channel with 1/2" x 36" drop rod and P2622 clamp.

**NOTE:**  
 \*Order channel length 8" longer than tray width.  
 For example, 44" channel for 36" tray.  
 \*\* Other channel types and finishes available upon request. Contact factory.  
 To order hardware only:  
 3/8" - PGV380000  
 1/2" - PGV120000

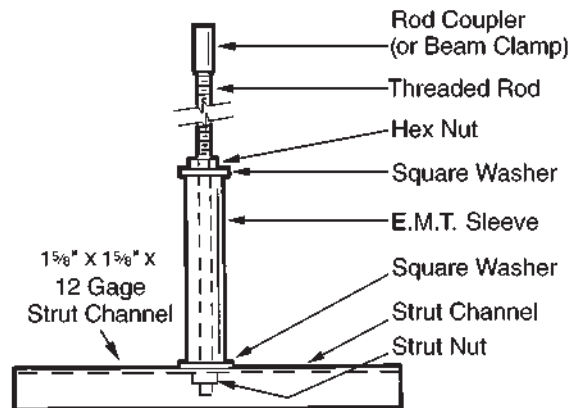

### Trapeze Hanger Support

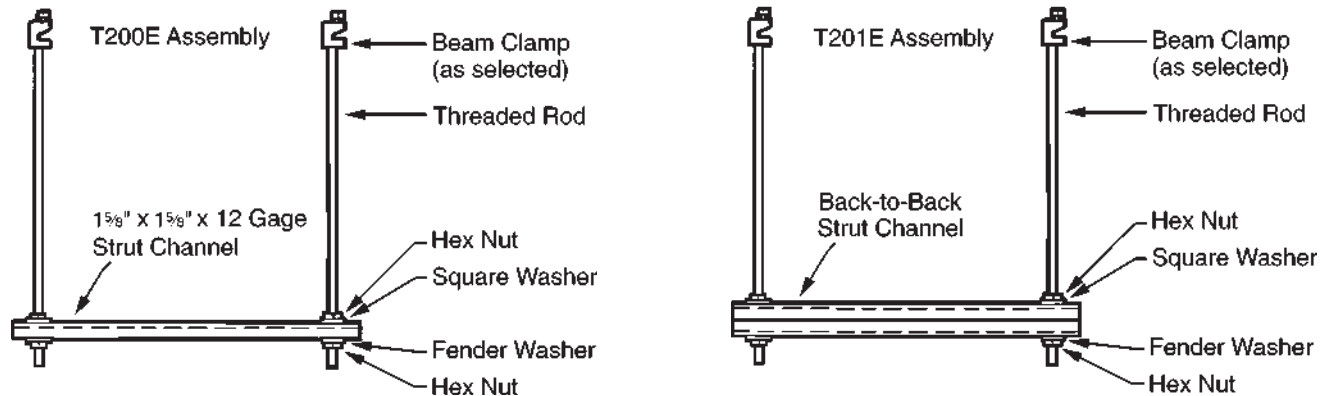

Catalog Number

| Assy. Type | Channel Length* | Channel Finish**     | Rod Diameter     | Rod Length          | Beam Clamp      |
|------------|-----------------|----------------------|------------------|---------------------|-----------------|
| T200E      | 16" (407mm)     | GV (Pre-Galv)        | 3/8" (9.53mm)    | 000 - No Rod        | A - PS 85       |
| T201E      | 19" (483mm)     | HG (Hot Dipped Galv) | 12=1/2" (12.7mm) | 036 - 36" (914mm)   | B - P2622       |
|            | 22" (559mm)     |                      |                  | 072 - 72" (1828mm)  | O - No Clamp    |
|            | 28" (712mm)     |                      |                  | 120 - 120" (3048mm) | R - Rod Coupler |
|            | 34" (864mm)     |                      |                  | 144 - 144" (3658mm) | S - Special     |
|            | 40" (1017mm)    |                      |                  |                     |                 |
|            | 46" (1169mm)    |                      |                  |                     |                 |

**EXAMPLE:** T200E22GV12036B is a Single 22" pre-galvanized channel with 1/2" x 36" drop rod and P2622 clamp.

**NOTE:** \*Order channel length 10" longer than tray width. For example, 46" channel for 36" tray.

\*\* Other channel types and finishes available upon request. Contact factory.

To order hardware only:

3/8" - PGV380000

1/2" - PGV120000

### Electrical Grounding Chart

Table 1 below provides the Minimum Cross Sectional area for two side rails. Using the Fitting Prefix Number (244), the proper value is determined by the Material (column 3), the Flange Width (column 1) and Load Depth (column 2). Locate the line containing the Load Depth (column 1) and follow it to the right to the appropriate Flange Width and Material.

Find that value in Table 2, follow it to the right to the Material column to determine the Maximum Ground Fault Amperage.

**TABLE 1**

| Fitting Prefix Number |            |              | Min. X-Sect for 2 Rails (NEC Table 392.7B) |               |               |               |
|-----------------------|------------|--------------|--|---------------|---------------|---------------|
|                       |            |              | Aluminum                                   |               | Steel         |               |
|                       |            |              | 13/16" Flange                              | 1 1/4" Flange | 13/16" Flange | 1 1/4" Flange |
| Flange                | Load Depth | Material     | X-Sect Area                                | X-Sect Area   | X-Sect Area   | X-Sect Area   |
| 2 - 13/16"            | 3"         | 2 - Mill Gal | 0.60                                       | -             | 0.40          | -             |
| 4 - 1 1/4"            | 4"         | 3 - HDGAF    | 0.60                                       | 0.60          | 0.40          | 0.70          |
|                       | 5"         | 4 - Alum.    | 0.60                                       | 1.00          | 0.70          | 0.70          |
|                       | 6"         |              | 0.60                                       | 1.00          | 0.70          | 1.00          |

**TABLE 2**

| Maximum Ground Fault Amperage (in Amps) |          |       |
|---|----------|-------|
| X-Sect Area                             | Material |       |
|   | Aluminum | Steel |
| .40 sq in                               | -        | 100   |
| .60 sq in                               | 1000     | -     |
| .70 sq in                               | -        | 200   |
| 1.00 sq in                              | 1200     | 400   |

**For Example:**

If the fitting prefix is 244, the Flange is 13/16", the Load Depth is 4", and the Material is Aluminum. The Minimum Cross Sectional Area (X-Sect Area) is 0.60 sq.in. The Amperage is 1000.

## Typical Specifications

By Specifying the NEMA class designation, you will use the simplest, clearest, and most complete method of specification available and automatically incorporate support span in feet, working (allowable) load in pounds per linear foot, a safety factor of 1.5, a concentrated load if present; and, all other design, manufacturing and test standards including electrical continuity.

All you need to add is inside depth, desired radius of fittings (to protect from cable damage), metal and finish. You can add accessory information pursuant to your project. Here is a typical specification for an outdoor tray system where the working (allowable) load has been determined to be approximately 75 pounds per foot on support spans of 12'-0"

## SPECIFICATION - ALUMINUM AB-COPE TROF

Cable Trof type tray shall be manufactured by a company regularly engaged in the manufacture of metal cable trays and shall be a member of NEMA. Trays shall conform to NEMA Metal Cable Tray Standard Publication VE-1 (latest issue).

1. Cable Trof shall be NEMA Classification 12B of the widths indicated.
2. Material shall be aluminum alloy with side rails of 6063 and bottoms of 5052 alloy.
3. Finish shall be natural.
4. Inside load depth to be NEMA Standard 3".
5. Fittings shall be 12" radius for control cables and 24" radius for power cables. (This must be commensurate with the cable manufacturer's recommended minimum bending radius.)
6. All top level trays in stacks and single runs to have raised peaked aluminum ventilated covers with heavy duty hold down clamps every 3'-0".
7. Install expansion connectors, expansion guides, and hold down clamps per NEMA Standard VE-1.
8. Where slopes or horizontal bends of trays are not at the Standard NEMA angles use adjustable connectors. If the angle is too great for cable bending radius, use combinations of fitting and adjustable connectors.
9. Separate all cables of different voltages in the same tray using the manufacturer's standard barriers and barrier hold down system.
10. The cable Trof system will be used as an equipment grounding conductor.
11. To save space, fittings shall have no tangents. To facilitate field installation, use one pair of universal type connector plates for rigid joints.
12. Cable Trof shall be three (3) piece construction with corrugated bottoms having 1" wide ribs on 2" centers arc welded to 3½", high side rails. Ventilating holes, 1½" diameter on 1" centers, shall be provided across valleys of the corrugations. Welds shall be MIG-arc type with approximately ½", diameter fused zone for rigidity to resist the rigors of shipping, installation, and service.
13. Trays shall be AB-Cope Trof as manufactured by AB-Cope standard design.



# AB-COPE CHANNEL

# 7

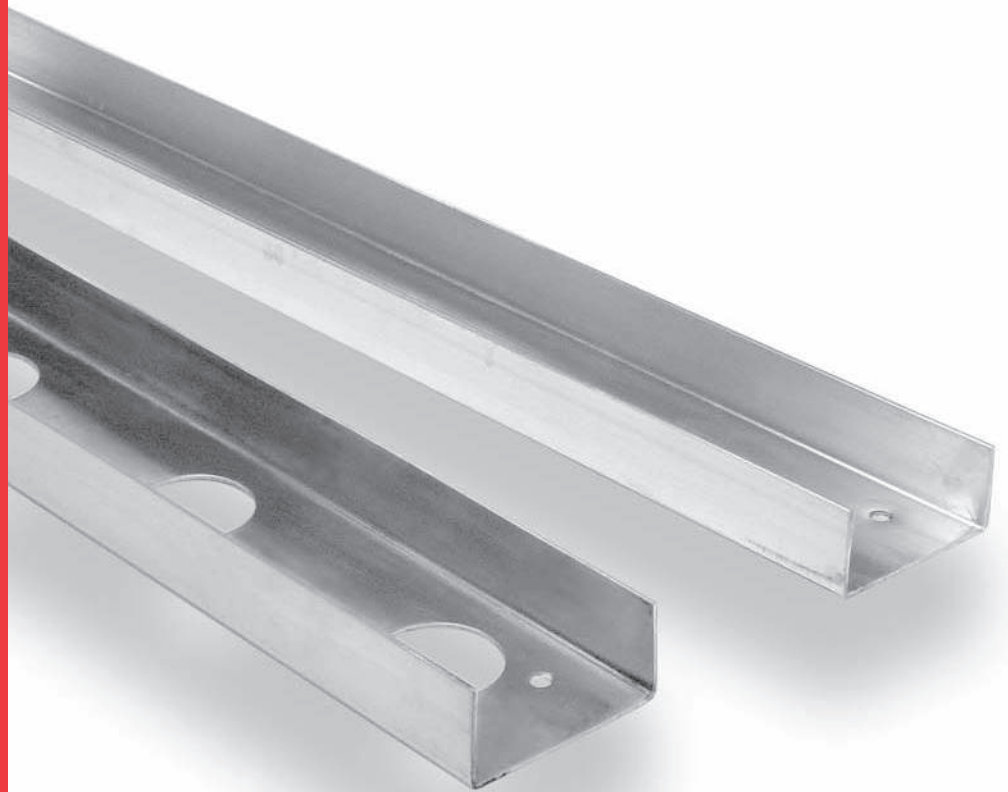

**Cable Tray for Branch Power Circuits,  
Control, Signal & Tubing Systems.**

# CHANNEL CABLE TRAY SYSTEM

## CONTENTS

### General and Technical Information

|                      |     |
|----------------------|-----|
| Pictorial Index..... | 172 |
| Straight Length..... | 173 |

### AB-Cope Channel Fittings

|                                      |           |
|--------------------------------------|-----------|
| Horizontal Elbows                    |           |
| 90°.....                             | 174       |
| 60°.....                             | 174       |
| 45°.....                             | 174       |
| 30°.....                             | 175       |
| Vertical Elbows (Inside and Outside) |           |
| 90°.....                             | 175       |
| 60°.....                             | 176       |
| 45°.....                             | 176 - 177 |
| 30°.....                             | 177       |
| Horizontal Tee.....                  | 178       |
| Horizontal Cross.....                | 178       |

### Accessories

|                                       |     |
|---------------------------------------|-----|
| Blind End.....                        | 179 |
| End Drop Out.....                     | 179 |
| Nylon Dropout Grommet.....            | 179 |
| Channel to Box or Wall Connector..... | 179 |
| Standard Connector.....               | 179 |
| Expansion Connector.....              | 180 |
| Channel Hold Down Clamp.....          | 180 |
| Adjustable Horizontal Connector.....  | 180 |
| Adjustable Riser Connector.....       | 180 |
| Cover Connector.....                  | 180 |
| Interconnections.....                 | 180 |
| Channel Hangers.....                  | 181 |

## Straight Length

Page 173

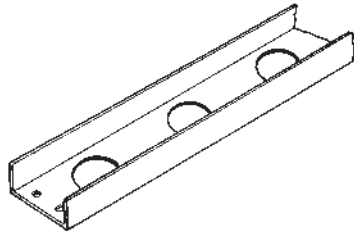

## Horizontal Cross

Page 178

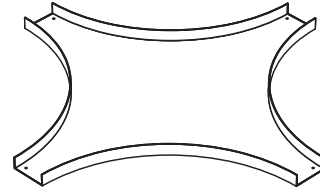

## Horizontal Elbows

Pages 174 - 175



## Barrier Strips & Accessories

Pages 179

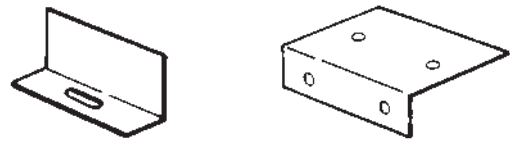

## Vertical Inside Elbow

Pages 176 - 177

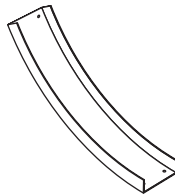

## Cover Attachments

Page 180

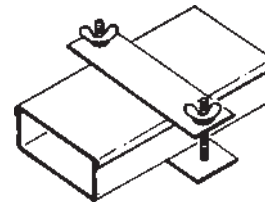

## Vertical Outside Elbow

Pages 175 - 177



## Adjustable Connectors

Page 180

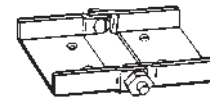

## Horizontal Tee

Page 178

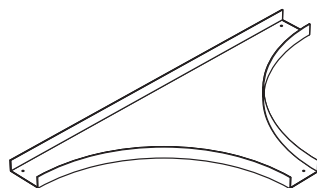

## Channel Hangers

Pages 181

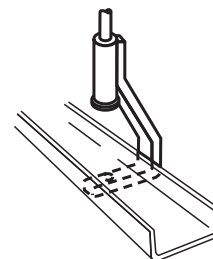

# CHANNEL CABLE TRAY SYSTEM



## INTRODUCTION

### AB-COPE CHANNEL

AB-Cope Channel supports single branches of power or multi-conductor control cable or instrument tubing. Ideal for communication, fire alarm, or call station and clock cabling. A complete line of devices are available for interfacing with AB-Cope Ladders and AB-Cope Trofs. Compatible with any cable tray system. AB-Cope Channel is more economical than conduit.

AB-Cope Channel is offered in both aluminum and steel, either hot dip mill galvanized (ASTM A 525), or hot dip galvanized after fabrication (ASTM A 386). Covers are available in aluminum and mill galvanized steel. Connectors are furnished with all straight sections and fittings. Other accessories must be ordered separately.

AB-Cope Channel is offered ventilated or solid. Basic units are 3", 4", or 6" wide and are 1 3/4" high. Standard lengths are 12' (3.7m) and 24' (7.4m) long. A load chart is furnished to give you guidance on how often you should support the system. Fitting radii available are 12", 24", and 36". AB-Cope Channel meets NEMA VE-1 standards for cable tray.

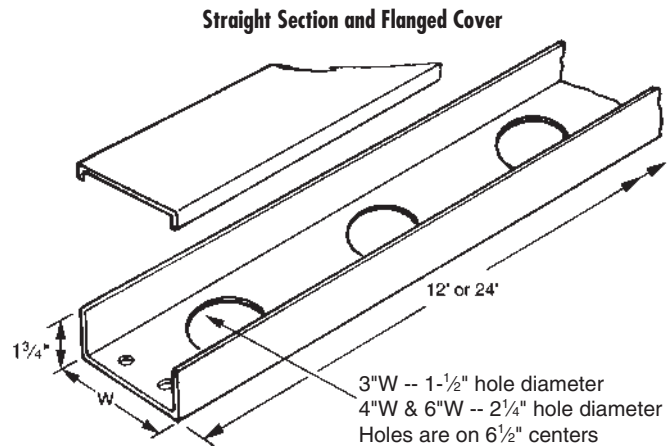

Catalog Number – Straight Section

| Finish            | Width      | Length              | Type       |
|-------------------|------------|---------------------|------------|
| 1124 - Alum.      | 3" (76mm)  | SL-12 = 12' (3.65m) | V - Vented |
| 6122 - Mill Galv. | 4" (102mm) | SL-24 = 24' (7.3m)  | S - Solid  |
| 6123 - HDGAF      | 6" (152mm) |                     |            |

EXAMPLE: 1124-04SL-12-V is a 4" wide, vented, 12' aluminum tray.

Catalog Number – Flanged Cover

| Finish            | Width      | Length              |
|-------------------|------------|---------------------|
| FS24 - Alum.      | 3" (76mm)  | SL-12 = 12' (3.65m) |
| FS22 - Mill Galv. | 4" (102mm) |                     |
|                   | 6" (152mm) |                     |

EXAMPLE: FS24-04SL-12 is a 4" wide, 12' aluminum cover.

NOTE: 24' length not available.

Catalog Number – Flanged Fitting Covers

| Finish            | Width/Basic No.  | Radius |
|-------------------|------------------|--------|
| FS24 - Alum.      | -03 XX * (76mm)  | 12"    |
| FS22 - Mill Galv. | -04 XX * (102mm) | 24"    |
|                   | -06 XX * (152mm) | 36"    |

EXAMPLE: FS24-034F-12 is a 3" wide, 45° Horizontal Elbow, 12" Radius fitting cover.

\*XX from fitting selection base part number

### ORDERING

For ordering, specify by catalog number using the following prefix to specify the material and finish.

Catalog Number Prefix

| Finish              | Straight Sections | Fittings, Accessories & Connectors | Covers |
|---------------------|-------------------|------------------------------------|--------|
| Aluminum            | 1124              | 24                                 | FS24   |
| Mill-Galv. Steel    | 6122              | 22                                 | FS22   |
| Hot-Dip Galv. Steel | 6123              | 23                                 | —      |

### Loads and Deflection

| Width   | Cope Channel Basic No. | 8' Span (2.4m) |              | 10' Span (3.0m) |               | 12' Span (3.7m) |               |
|---|------------------------|----------------|--------------|-----------------|---------------|-----------------|---------------|
|   |                        | #/Lin Ft*      | Deflection   | #/Lin Ft*       | Deflection    | #/Lin Ft*       | Deflection    |
| <b>Aluminum-Plain Finish</b>  |                        |                |              |                 |               |                 |               |
| 3" (76mm)   | 1124-03SL              | 8              | .21" (5.3mm) | 5               | .33" (8.4mm)  | 3               | .40" (10.6mm) |
| 4" (102mm)  | 1124-04SL              | 13             | .34" (8.6mm) | 9               | .57" (14.5mm) | 6               | .79" (20.2mm) |
| 6" (152mm)  | 1124-06SL              | 15             | .37" (9.4mm) | 10              | .61" (15.5mm) | 6               | .76" (19.3mm) |
| <b>Hot Dip Mill-Galvanized Steel (ASTM A-525)</b>                         |                        |                |              |                 |               |                 |               |
| 3" (76mm)   | 6122-03SL              | 8              | .13" (3.3mm) | 5               | .20" (5.1mm)  | 3               | .25" (6.4mm)  |
| 4" (102mm)  | 6122-04SL              | 13             | .21" (5.3mm) | 9               | .35" (8.9mm)  | 6               | .48" (12.2mm) |
| 6" (152mm)  | 6122-06SL              | 15             | .23" (5.8mm) | 10              | .37" (9.4mm)  | 6               | .46" (11.7mm) |
| <b>Hot Dip Galvanized Steel (ASTM A-386), Covers Mill-Galvanized Only</b> |                        |                |              |                 |               |                 |               |
| 3" (76mm)   | 6123-03SL              | 8              | .13" (3.3mm) | 5               | .20" (5.1mm)  | 3               | .25" (6.4mm)  |
| 4" (102mm)  | 6123-04SL              | 13             | .21" (5.3mm) | 9               | .35" (8.9mm)  | 6               | .48" (12.2mm) |
| 6" (152mm)  | 6123-06SL              | 15             | .23" (5.8mm) | 10              | .37" (9.4mm)  | 6               | .46" (11.7mm) |

(\* For kg/m multiply #/Lin Ft by 1.48

### 90° Horizontal Elbow [9F]

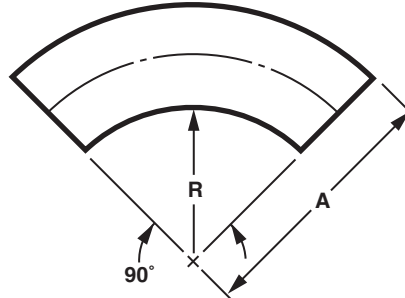
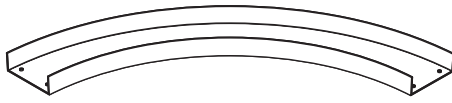

| Radius - R     | Width - W  | "A" Dim. |          |
|----------------|------------|----------|----------|
| 12"<br>(305mm) | 3" (76mm)  | 15"      | (381mm)  |
|                | 4" (102mm) | 16"      | (406mm)  |
|                | 6" (152mm) | 18"      | (457mm)  |
| 24"<br>(610mm) | 3" (76mm)  | 17"      | (432mm)  |
|                | 4" (102mm) | 28"      | (711mm)  |
|                | 6" (152mm) | 30"      | (762mm)  |
| 36"<br>(914mm) | 3" (76mm)  | 39"      | (991mm)  |
|                | 4" (102mm) | 40"      | (1016mm) |
|                | 6" (152mm) | 42"      | (1067mm) |

### 60° Horizontal Elbow [6F]

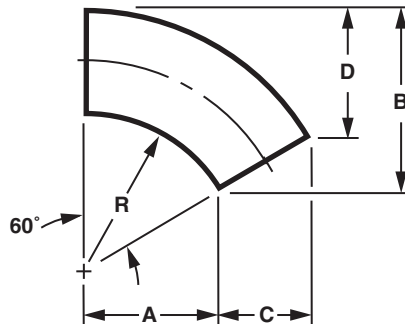
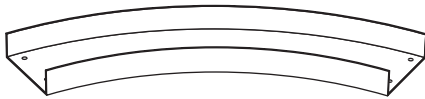

| Radius-R       | Width - W  | "A" Dim.                                 | "B" Dim.    | "C" Dim.                                | "D" Dim.                                 |
|----------------|------------|--|-------------|---|--|
| 12"<br>(305mm) | 3" (76mm)  | 10 <sup>3</sup> / <sub>8</sub> " (264mm) | 9" (229mm)  | 2 <sup>5</sup> / <sub>8</sub> " (66mm)  | 7 <sup>1</sup> / <sub>2</sub> " (191mm)  |
|                | 4" (102mm) | 10 <sup>3</sup> / <sub>8</sub> " (264mm) | 10" (254mm) | 3 <sup>1</sup> / <sub>2</sub> " (887mm) | 8" (203mm)                               |
|                | 6" (152mm) | 10 <sup>3</sup> / <sub>8</sub> " (264mm) | 12" (305mm) | 5 <sup>1</sup> / <sub>4</sub> " (132mm) | 9" (229mm)                               |
| 24"<br>(610mm) | 3" (76mm)  | 20 <sup>3</sup> / <sub>4</sub> " (528mm) | 15" (381mm) | 2 <sup>5</sup> / <sub>8</sub> " (66mm)  | 13 <sup>1</sup> / <sub>2</sub> " (343mm) |
|                | 4" (102mm) | 20 <sup>3</sup> / <sub>4</sub> " (528mm) | 16" (406mm) | 3 <sup>1</sup> / <sub>2</sub> " (88mm)  | 14" (356mm)                              |
|                | 6" (152mm) | 20 <sup>3</sup> / <sub>4</sub> " (528mm) | 18" (457mm) | 5 <sup>1</sup> / <sub>4</sub> " (132mm) | 15" (381mm)                              |
| 36"<br>(914mm) | 3" (76mm)  | 31 <sup>1</sup> / <sub>4</sub> " (792mm) | 21" (533mm) | 2 <sup>5</sup> / <sub>8</sub> " (66mm)  | 19 <sup>1</sup> / <sub>2</sub> " (495mm) |
|                | 4" (102mm) | 31 <sup>1</sup> / <sub>4</sub> " (792mm) | 22" (559mm) | 3 <sup>1</sup> / <sub>2</sub> " (88mm)  | 20" (508mm)                              |
|                | 6" (152mm) | 31 <sup>1</sup> / <sub>4</sub> " (792mm) | 24" (610mm) | 5 <sup>1</sup> / <sub>4</sub> " (132mm) | 21" (553mm)                              |

### 45° Horizontal Elbow [4F]

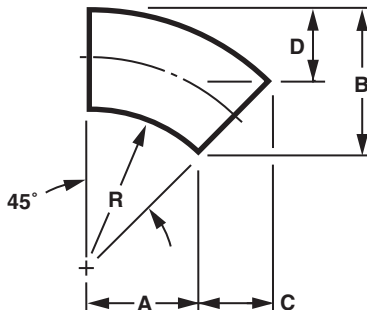

| Radius-R       | Width - W  | "A" Dim.                                 | "B" Dim.                                 | "C" Dim.                                | "D" Dim.                                 |
|----------------|------------|--|--|---|--|
| 12"<br>(305mm) | 3" (76mm)  | 8 <sup>1</sup> / <sub>2</sub> " (216mm)  | 6 <sup>1</sup> / <sub>2</sub> " (165mm)  | 2 <sup>1</sup> / <sub>8</sub> " (54mm)  | 4 <sup>3</sup> / <sub>8</sub> " (112mm)  |
|                | 4" (102mm) | 8 <sup>1</sup> / <sub>2</sub> " (216mm)  | 7 <sup>1</sup> / <sub>2</sub> " (191mm)  | 2 <sup>7</sup> / <sub>8</sub> " (71mm)  | 4 <sup>3</sup> / <sub>4</sub> " (119mm)  |
|                | 6" (152mm) | 8 <sup>1</sup> / <sub>2</sub> " (216mm)  | 9 <sup>1</sup> / <sub>2</sub> " (241mm)  | 4 <sup>1</sup> / <sub>4</sub> " (108mm) | 5 <sup>3</sup> / <sub>4</sub> " (134mm)  |
| 24"<br>(610mm) | 3" (76mm)  | 17 <sup>1</sup> / <sub>8</sub> " (431mm) | 10 <sup>1</sup> / <sub>8</sub> " (255mm) | 2 <sup>1</sup> / <sub>8</sub> " (54mm)  | 7 <sup>7</sup> / <sub>8</sub> " (201mm)  |
|                | 4" (102mm) | 17 <sup>1</sup> / <sub>8</sub> " (431mm) | 11 <sup>1</sup> / <sub>8</sub> " (280mm) | 2 <sup>7</sup> / <sub>8</sub> " (71mm)  | 8 <sup>1</sup> / <sub>4</sub> " (208mm)  |
|                | 6" (152mm) | 17 <sup>1</sup> / <sub>8</sub> " (431mm) | 13 <sup>1</sup> / <sub>8</sub> " (331mm) | 4 <sup>1</sup> / <sub>4</sub> " (108mm) | 8 <sup>3</sup> / <sub>4</sub> " (223mm)  |
| 36"<br>(914mm) | 3" (76mm)  | 25 <sup>1</sup> / <sub>2</sub> " (647mm) | 13 <sup>5</sup> / <sub>8</sub> " (344mm) | 2 <sup>1</sup> / <sub>8</sub> " (54mm)  | 11 <sup>1</sup> / <sub>2</sub> " (291mm) |
|                | 4" (102mm) | 25 <sup>1</sup> / <sub>2</sub> " (647mm) | 14 <sup>5</sup> / <sub>8</sub> " (370mm) | 2 <sup>7</sup> / <sub>8</sub> " (71mm)  | 11 <sup>3</sup> / <sub>4</sub> " (298mm) |
|                | 6" (152mm) | 25 <sup>1</sup> / <sub>2</sub> " (647mm) | 16 <sup>5</sup> / <sub>8</sub> " (421mm) | 4 <sup>1</sup> / <sub>4</sub> " (108mm) | 12 <sup>3</sup> / <sub>8</sub> " (313mm) |

Ordering Information:

Prefix No.

**[M] - [W] [Bp] - [R] - [B]**

Material Finish (22=Mill-Galv. Steel, 23=Hot-Dip-Galv. Steel, 24=Aluminum)

Width (03", 04", 06")

Radius (12", 24", 36")

Bottom (S=Solid, V=Ventilated)

Basic Part (9F, 6F, 4F)

## FITTINGS

### 30° Horizontal Elbow [3F]

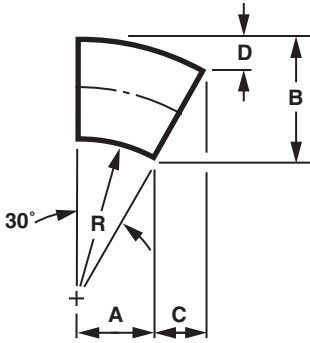

| Radius-R       | Width - W  | "A" Dim.    | "B" Dim.                                 | "C" Dim.                               | "D" Dim.                                |
|----------------|------------|-------------|--|--|---|
| 12"<br>(305mm) | 3" (76mm)  | 6" (152mm)  | 4 <sup>5</sup> / <sub>8</sub> " (117mm)  | 1 <sup>1</sup> / <sub>2</sub> " (38mm) | 2" (51mm)                               |
|                | 4" (102mm) | 6" (152mm)  | 5 <sup>5</sup> / <sub>8</sub> " (143mm)  | 2" (51mm)                              | 2 <sup>1</sup> / <sub>8</sub> " (55mm)  |
|                | 6" (152mm) | 6" (152mm)  | 7 <sup>5</sup> / <sub>8</sub> " (194mm)  | 3" (76mm)                              | 2 <sup>3</sup> / <sub>8</sub> " (61mm)  |
| 24"<br>(610mm) | 3" (76mm)  | 12" (305mm) | 6 <sup>1</sup> / <sub>4</sub> " (158mm)  | 1 <sup>1</sup> / <sub>2</sub> " (38mm) | 3 <sup>5</sup> / <sub>8</sub> " (92mm)  |
|                | 4" (102mm) | 12" (305mm) | 7 <sup>1</sup> / <sub>4</sub> " (183mm)  | 2" (51mm)                              | 3 <sup>3</sup> / <sub>4</sub> " (95mm)  |
|                | 6" (152mm) | 12" (305mm) | 9 <sup>1</sup> / <sub>4</sub> " (234mm)  | 3" (76mm)                              | 4" (102mm)                              |
| 36"<br>(914mm) | 3" (76mm)  | 18" (457mm) | 7 <sup>7</sup> / <sub>8</sub> " (198mm)  | 1 <sup>1</sup> / <sub>2</sub> " (38mm) | 5 <sup>1</sup> / <sub>4</sub> " (133mm) |
|                | 4" (102mm) | 18" (457mm) | 8 <sup>7</sup> / <sub>8</sub> " (224mm)  | 2" (51mm)                              | 5 <sup>3</sup> / <sub>8</sub> " (137mm) |
|                | 6" (152mm) | 18" (457mm) | 10 <sup>7</sup> / <sub>8</sub> " (275mm) | 3" (76mm)                              | 5 <sup>5</sup> / <sub>8</sub> " (143mm) |

### 90° Vertical Inside Elbow [9I]

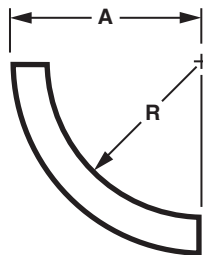
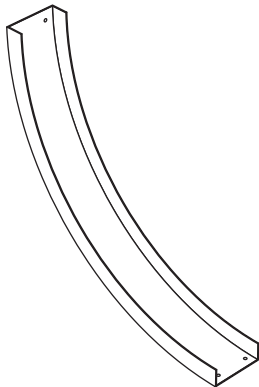

| Radius - R     | Width - W  | "A" Dimension |
|----------------|------------|---------------|
| 12"<br>(305mm) | 3" (76mm)  | 12" (305mm)   |
|                | 4" (102mm) | 12" (305mm)   |
|                | 6" (152mm) | 12" (305mm)   |
| 24"<br>(610mm) | 3" (76mm)  | 24" (610mm)   |
|                | 4" (102mm) | 24" (610mm)   |
|                | 6" (152mm) | 24" (610mm)   |
| 36"<br>(914mm) | 3" (76mm)  | 36" (914mm)   |
|                | 4" (102mm) | 36" (914mm)   |
|                | 6" (152mm) | 36" (914mm)   |

### 90° Vertical Outside Elbow [9O]

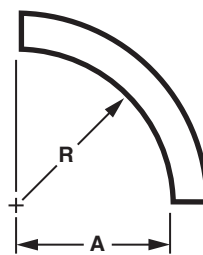
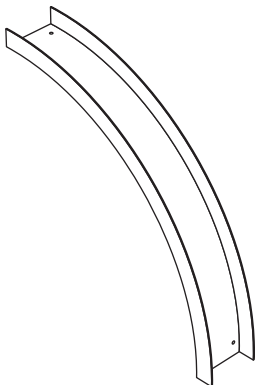

| Radius - R     | Width - W  | "A" Dimension                            |
|----------------|------------|--|
| 12"<br>(305mm) | 3" (76mm)  | 13 <sup>3</sup> / <sub>4</sub> " (349mm) |
|                | 4" (102mm) | 13 <sup>3</sup> / <sub>4</sub> " (349mm) |
|                | 6" (152mm) | 13 <sup>3</sup> / <sub>4</sub> " (349mm) |
| 24"<br>(610mm) | 3" (76mm)  | 25 <sup>3</sup> / <sub>4</sub> " (654mm) |
|                | 4" (102mm) | 25 <sup>3</sup> / <sub>4</sub> " (654mm) |
|                | 6" (152mm) | 25 <sup>3</sup> / <sub>4</sub> " (654mm) |
| 36"<br>(914mm) | 3" (76mm)  | 37 <sup>3</sup> / <sub>4</sub> " (959mm) |
|                | 4" (102mm) | 37 <sup>3</sup> / <sub>4</sub> " (959mm) |
|                | 6" (152mm) | 37 <sup>3</sup> / <sub>4</sub> " (959mm) |

Ordering Information:

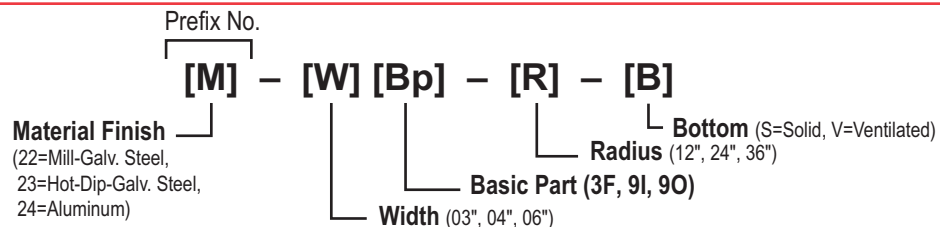

## 60° Vertical Inside Elbow [6I]

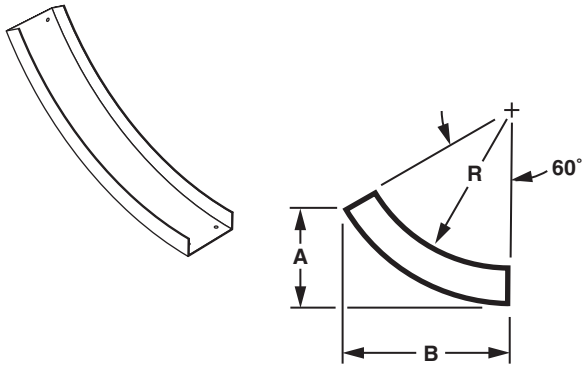

| Radius - R     | Width - W  | "A" Dim.                                 | "B" Dim.                                 |
|----------------|------------|--|--|
| 12"<br>(305mm) | 3" (76mm)  | 6 <sup>7</sup> / <sub>8</sub> " (175mm)  | 11 <sup>7</sup> / <sub>8</sub> " (302mm) |
|                | 4" (102mm) | 6 <sup>7</sup> / <sub>8</sub> " (175mm)  | 11 <sup>7</sup> / <sub>8</sub> " (302mm) |
|                | 6" (152mm) | 6 <sup>7</sup> / <sub>8</sub> " (175mm)  | 11 <sup>7</sup> / <sub>8</sub> " (302mm) |
| 24"<br>(610mm) | 3" (76mm)  | 12 <sup>7</sup> / <sub>8</sub> " (327mm) | 22 <sup>1</sup> / <sub>4</sub> " (567mm) |
|                | 4" (102mm) | 12 <sup>7</sup> / <sub>8</sub> " (327mm) | 22 <sup>1</sup> / <sub>4</sub> " (567mm) |
|                | 6" (152mm) | 12 <sup>7</sup> / <sub>8</sub> " (327mm) | 22 <sup>1</sup> / <sub>4</sub> " (567mm) |
| 36"<br>(914mm) | 3" (76mm)  | 18 <sup>7</sup> / <sub>8</sub> " (479mm) | 32 <sup>3</sup> / <sub>4</sub> " (830mm) |
|                | 4" (102mm) | 18 <sup>7</sup> / <sub>8</sub> " (479mm) | 32 <sup>3</sup> / <sub>4</sub> " (830mm) |
|                | 6" (152mm) | 18 <sup>7</sup> / <sub>8</sub> " (479mm) | 32 <sup>3</sup> / <sub>4</sub> " (830mm) |

## 60° Vertical Outside Elbow [6O]

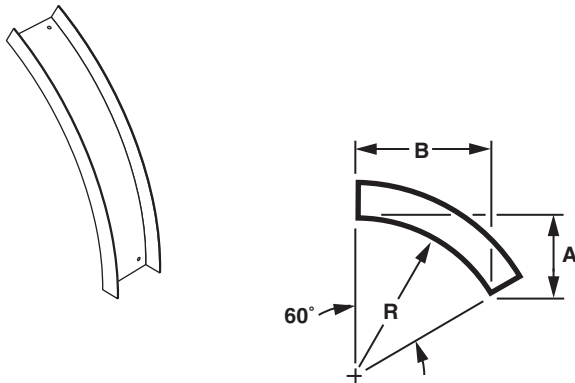

| Radius - R     | Width - W  | "A" Dim.    | "B" Dim.                                 |
|----------------|------------|-------------|--|
| 12"<br>(305mm) | 3" (76mm)  | 6" (152mm)  | 10 <sup>3</sup> / <sub>8</sub> " (264mm) |
|                | 4" (102mm) | 6" (152mm)  | 10 <sup>3</sup> / <sub>8</sub> " (264mm) |
|                | 6" (152mm) | 6" (152mm)  | 10 <sup>3</sup> / <sub>8</sub> " (264mm) |
| 24"<br>(610mm) | 3" (76mm)  | 12" (305mm) | 20 <sup>3</sup> / <sub>4</sub> " (528mm) |
|                | 4" (102mm) | 12" (305mm) | 20 <sup>3</sup> / <sub>4</sub> " (528mm) |
|                | 6" (152mm) | 12" (305mm) | 20 <sup>3</sup> / <sub>4</sub> " (528mm) |
| 36"<br>(914mm) | 3" (76mm)  | 18" (457mm) | 31 <sup>1</sup> / <sub>4</sub> " (792mm) |
|                | 4" (102mm) | 18" (457mm) | 31 <sup>1</sup> / <sub>4</sub> " (792mm) |
|                | 6" (152mm) | 18" (457mm) | 31 <sup>1</sup> / <sub>4</sub> " (792mm) |

## 45° Vertical Inside Elbow [4I]

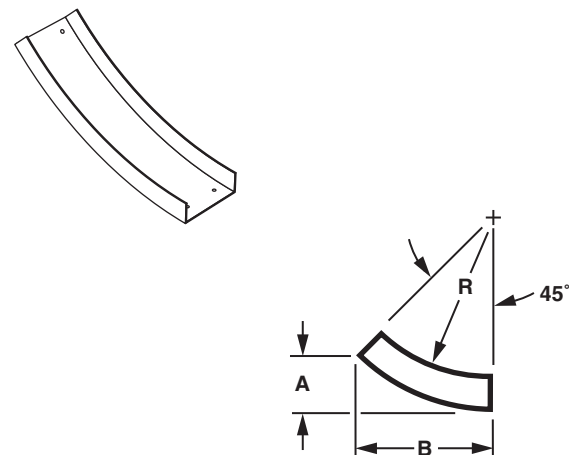

| Radius - R     | Width - W  | "A" Dim.                                 | "B" Dim.                                 |
|----------------|------------|--|--|
| 12"<br>(305mm) | 3" (76mm)  | 4 <sup>1</sup> / <sub>8</sub> " (102mm)  | 9 <sup>3</sup> / <sub>4</sub> " (247mm)  |
|                | 4" (102mm) | 4 <sup>1</sup> / <sub>8</sub> " (102mm)  | 9 <sup>3</sup> / <sub>4</sub> " (247mm)  |
|                | 6" (152mm) | 4 <sup>1</sup> / <sub>8</sub> " (102mm)  | 9 <sup>3</sup> / <sub>4</sub> " (247mm)  |
| 24"<br>(610mm) | 3" (76mm)  | 7 <sup>1</sup> / <sub>2</sub> " (191mm)  | 18 <sup>1</sup> / <sub>4</sub> " (463mm) |
|                | 4" (102mm) | 7 <sup>1</sup> / <sub>2</sub> " (191mm)  | 18 <sup>1</sup> / <sub>4</sub> " (463mm) |
|                | 6" (152mm) | 7 <sup>1</sup> / <sub>2</sub> " (191mm)  | 18 <sup>1</sup> / <sub>4</sub> " (463mm) |
| 36"<br>(914mm) | 3" (76mm)  | 11 <sup>1</sup> / <sub>8</sub> " (281mm) | 26 <sup>3</sup> / <sub>4</sub> " (678mm) |
|                | 4" (102mm) | 11 <sup>1</sup> / <sub>8</sub> " (281mm) | 26 <sup>3</sup> / <sub>4</sub> " (678mm) |
|                | 6" (152mm) | 11 <sup>1</sup> / <sub>8</sub> " (281mm) | 26 <sup>3</sup> / <sub>4</sub> " (678mm) |

Ordering Information:

Prefix No.  
**[M] - [W] [Bp] - [R] - [R]**  
 Material Finish (22=Mill-Galv. Steel, 23=Hot-Dip-Galv. Steel, 24=Aluminum)  
 Width (03", 04", 06")  
 Basic Part (6I, 6O, 4I)  
 Radius (12", 24", 36")  
 Bottom (S=Solid, V=Ventilated)

## FITTINGS

### 45° Vertical Outside Elbow [40]

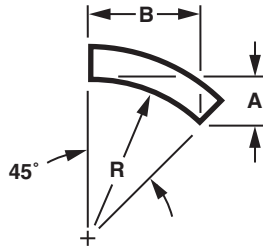
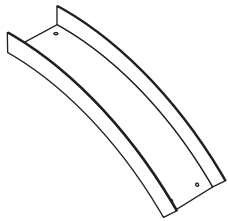

| Radius - R     | Width - W  | "A" Dim.        | "B" Dim.        |
|----------------|------------|-----------------|-----------------|
| 12"<br>(305mm) | 3" (76mm)  | 3 1/2" (89mm)   | 8 1/2" (216mm)  |
|                | 4" (102mm) | 3 1/2" (89mm)   | 8 1/2" (216mm)  |
|                | 6" (152mm) | 3 1/2" (89mm)   | 8 1/2" (216mm)  |
| 24"<br>(610mm) | 3" (76mm)  | 7 1/8" (179mm)  | 17 1/8" (431mm) |
|                | 4" (102mm) | 7 1/8" (179mm)  | 17 1/8" (431mm) |
|                | 6" (152mm) | 7 1/8" (179mm)  | 17 1/8" (431mm) |
| 36"<br>(914mm) | 3" (76mm)  | 10 1/2" (268mm) | 25 1/8" (646mm) |
|                | 4" (102mm) | 10 1/2" (268mm) | 25 1/8" (646mm) |
|                | 6" (152mm) | 10 1/2" (268mm) | 25 1/8" (646mm) |

### 30° Vertical Inside Elbow [3I]

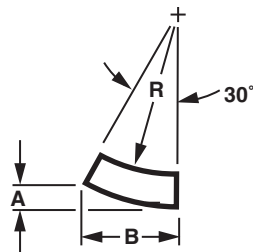
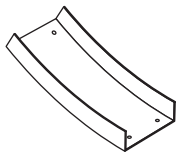

| Radius - R     | Width - W  | "A" Dim.       | "B" Dim.        |
|----------------|------------|----------------|-----------------|
| 12"<br>(305mm) | 3" (76mm)  | 1 7/8" (47mm)  | 6 7/8" (175mm)  |
|                | 4" (102mm) | 1 7/8" (47mm)  | 6 7/8" (175mm)  |
|                | 6" (152mm) | 1 7/8" (47mm)  | 6 7/8" (175mm)  |
| 24"<br>(610mm) | 3" (76mm)  | 3 1/2" (87mm)  | 12 7/8" (327mm) |
|                | 4" (102mm) | 3 1/2" (87mm)  | 12 7/8" (327mm) |
|                | 6" (152mm) | 3 1/2" (87mm)  | 12 7/8" (327mm) |
| 36"<br>(914mm) | 3" (76mm)  | 5 1/8" (129mm) | 18 7/8" (479mm) |
|                | 4" (102mm) | 5 1/8" (129mm) | 18 7/8" (479mm) |
|                | 6" (152mm) | 5 1/8" (129mm) | 18 7/8" (479mm) |

### 30° Vertical Outside Elbow [30]

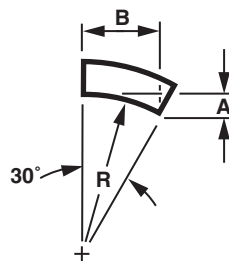
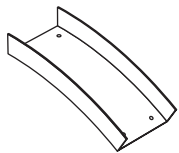

| Radius - R     | Width - W  | "A" Dim.       | "B" Dim.    |
|----------------|------------|----------------|-------------|
| 12"<br>(305mm) | 3" (76mm)  | 1 5/8" (40mm)  | 6" (152mm)  |
|                | 4" (102mm) | 1 5/8" (40mm)  | 6" (152mm)  |
|                | 6" (152mm) | 1 5/8" (40mm)  | 6" (152mm)  |
| 24"<br>(610mm) | 3" (76mm)  | 3 1/4" (82mm)  | 12" (305mm) |
|                | 4" (102mm) | 3 1/4" (82mm)  | 12" (305mm) |
|                | 6" (152mm) | 3 1/4" (82mm)  | 12" (305mm) |
| 36"<br>(914mm) | 3" (76mm)  | 4 7/8" (122mm) | 18" (457mm) |
|                | 4" (102mm) | 4 7/8" (122mm) | 18" (457mm) |
|                | 6" (152mm) | 4 7/8" (122mm) | 18" (457mm) |

Ordering Information:

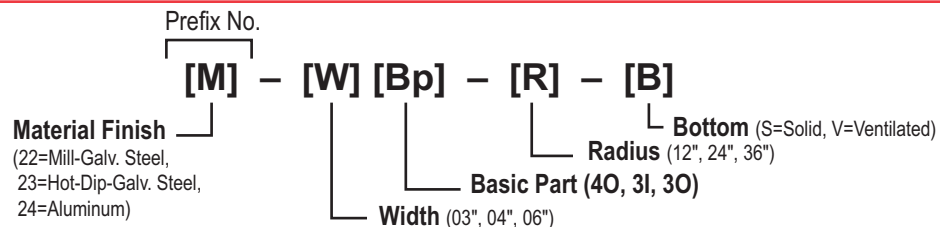

## Horizontal Tee [FT]

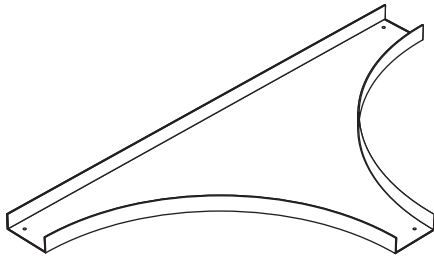

| Radius - R     | Width - W  | "A" Dim.     | "B" Dim.     |
|----------------|------------|--------------|--------------|
| 12"<br>(305mm) | 3" (76mm)  | 27" (686mm)  | 15" (381mm)  |
|                | 4" (102mm) | 28" (711mm)  | 16" (406mm)  |
|                | 6" (152mm) | 30" (762mm)  | 18" (457mm)  |
| 24"<br>(610mm) | 3" (76mm)  | 51" (1275mm) | 27" (686mm)  |
|                | 4" (102mm) | 52" (1321mm) | 28" (711mm)  |
|                | 6" (152mm) | 54" (1372mm) | 30" (762mm)  |
| 36"<br>(914mm) | 3" (76mm)  | 75" (1905mm) | 39" (991mm)  |
|                | 4" (102mm) | 76" (1930mm) | 40" (1016mm) |
|                | 6" (152mm) | 78" (1981mm) | 42" (1067mm) |

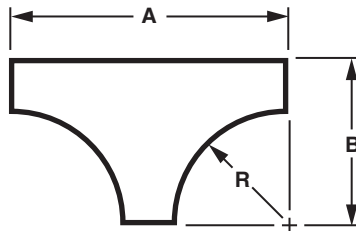

## Horizontal Cross [FC]

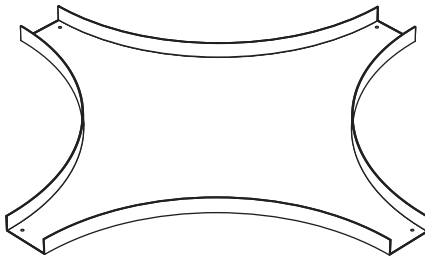

| Radius - R     | Width - W  | Catalog No.    | "A" Dim.     |
|----------------|------------|----------------|--------------|
| 12"<br>(305mm) | 3" (76mm)  | Prefix-03FC-12 | 27" (686mm)  |
|                | 4" (102mm) | Prefix-04FC-12 | 28" (711mm)  |
|                | 6" (152mm) | Prefix-06FC-12 | 30" (762mm)  |
| 24"<br>(610mm) | 3" (76mm)  | Prefix-03FC-24 | 51" (1295mm) |
|                | 4" (102mm) | Prefix-04FC-24 | 52" (1321mm) |
|                | 6" (152mm) | Prefix-06FC-24 | 54" (1372mm) |
| 36"<br>(914mm) | 3" (76mm)  | Prefix-03FC-36 | 75" (1905mm) |
|                | 4" (102mm) | Prefix-04FC-36 | 76" (1930mm) |
|                | 6" (152mm) | Prefix-06FC-36 | 78" (1981mm) |

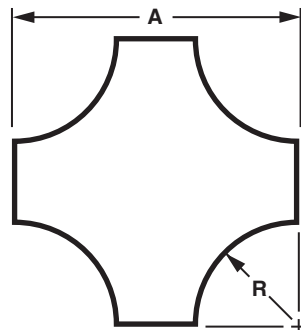

Ordering Information:

Prefix No.

[M] - [W] [Bp] - [R] - [B]

Material Finish (22=Mill-Galv. Steel, 23=Hot-Dip-Galv. Steel, 24=Aluminum)

Width (03", 04", 06")

Basic Part (FT, FC)

Radius (12", 24", 36")

Bottom (S=Solid, V=Ventilated)

## ACCESSORIES

### Blind End [BE]

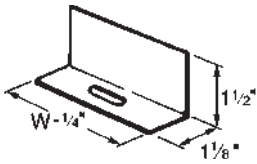

| W          | Catalog No. |
|------------|-------------|
| 3" (76mm)  | Prefix-03BE |
| 4" (102mm) | Prefix-04BE |
| 6" (152mm) | Prefix-06BE |

Steel Plated, Furnished with one set 1/4" x 3/4" bolt, nut and washer.

### End Dropout [DO]

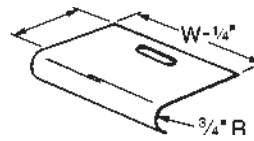

| W          | Catalog No. |
|------------|-------------|
| 3" (76mm)  | Prefix-03DO |
| 4" (102mm) | Prefix-04DO |
| 6" (152mm) | Prefix-06DO |

Prefixes:  
 22 = Mill-Galv. Steel,  
 23 = Hot-Dip Galv. Steel,  
 24 = Aluminum  
 Steel plated, Furnished with one set 1/4" x 3/4" bolt, nut and washer.

### Channel to Box or Wall Connector [CB]

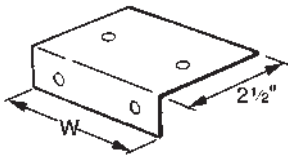

| W          | Catalog No. |
|------------|-------------|
| 3" (76mm)  | Prefix-03CB |
| 4" (102mm) | Prefix-04CB |
| 6" (152mm) | Prefix-06CB |

Prefixes:  
 22 = Mill-Galv. Steel,  
 23 = Hot-Dip Galv. Steel,  
 24 = Aluminum  
 Furnished with two sets 3/8" x 3/4" bolt, nut and washer. Steel plated.

### Nylon Dropout Grommet [DOG-1]

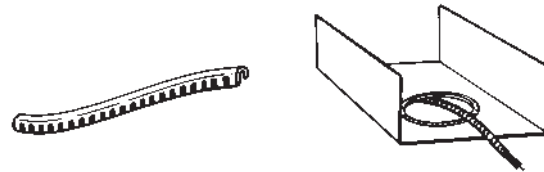

Use at cable dropouts, over sides or thru vent holes.  
 Furnished in 12' lengths. Cut to length in field.

### Standard Connector [CS]

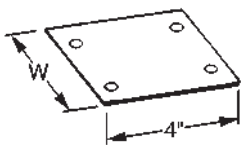

| W          | Catalog No. |
|------------|-------------|
| 3" (76mm)  | Prefix-03CS |
| 4" (102mm) | Prefix-04CS |
| 6" (152mm) | Prefix-06CS |

Prefixes:  
 22 = Mill-Galv. Steel,  
 23 = Hot-Dip Galv. Steel,  
 24 = Aluminum  
 Hardware: 3/8" x 3/4" Bolt and flanged nut  
 Steel plated incl. (4-sets)

### Expansion Connector [CE]

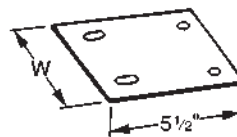

| W          | Catalog No. |
|------------|-------------|
| 3" (76mm)  | Prefix-03CE |
| 4" (102mm) | Prefix-04CE |
| 6" (152mm) | Prefix-06CE |

Prefixes:  
 22 = Mill-Galv. Steel,  
 23 = Hot-Dip Galv. Steel,  
 24 = Aluminum  
 Hardware: 3/8" x 3/4" Bolt and flanged nut  
 Steel plated incl. (4-sets)

## ACCESSORIES, INTERCONNECTIONS

### Adjustable Horizontal Connector [CH]

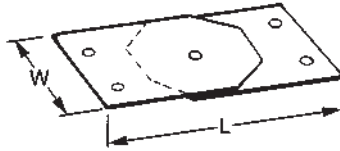

| W          | L            | Catalog No. |
|------------|--------------|-------------|
| 3" (76mm)  | 7½" (191mm)  | Prefix-03CH |
| 4" (102mm) | 8½" (216mm)  | Prefix-04CH |
| 6" (152mm) | 10½" (267mm) | Prefix-06CH |

Prefixes:

- 22 = Mill-Galv. Steel,
- 23 = Hot-Dip Galv. Steel,
- 24 = Aluminum

Hardware: 3/8" x 3/4" Bolt and flanged nut  
Steel plated incl. (4-sets)

### Adjustable Riser Connector [CV]

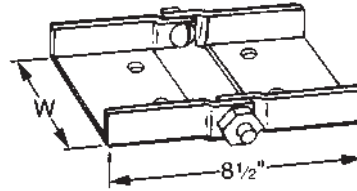

| W          | Catalog No. |
|------------|-------------|
| 3" (76mm)  | Prefix-03CV |
| 4" (102mm) | Prefix-04CV |
| 6" (152mm) | Prefix-06CV |

Prefixes:

- 22 = Mill-Galv. Steel,
- 23 = Hot-Dip Galv. Steel,
- 24 = Aluminum

Hardware: 1/4" x 2 1/4" Machine screw and wing nut. Steel plated incl. (2-sets)

### Cover Connector [CC]

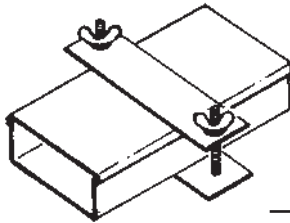

| W          | Catalog No. |
|------------|-------------|
| 3" (76mm)  | Prefix-03CC |
| 4" (102mm) | Prefix-04CC |
| 6" (152mm) | Prefix-06CC |

Prefixes:

- 22 = Mill-Galv. Steel,
- 23 = Hot-Dip Galv. Steel,
- 24 = Aluminum

Hardware: 3/8" x 3/4" Bolt and flanged nut  
Steel plated incl. (4-sets)

### Channel Holddown Clamp (Stainless Steel) [9079]

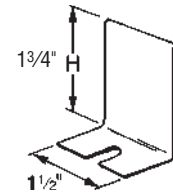

For use with steel or aluminum systems.

(No hardware included.)

### Interconnections

9019-1 (3/4" L)

5/16" Dia.

Bolt, Nut, & Washer

70620  
Conduit Clamp  
Bracket

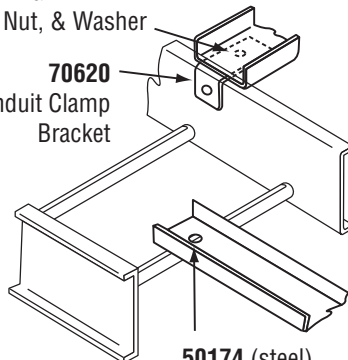

50174 (steel)

50174 (Alum.)

Rung Clamp with Hardware

70620  
Conduit Clamp  
Bracket with  
Mounting  
Hardware

9019-1

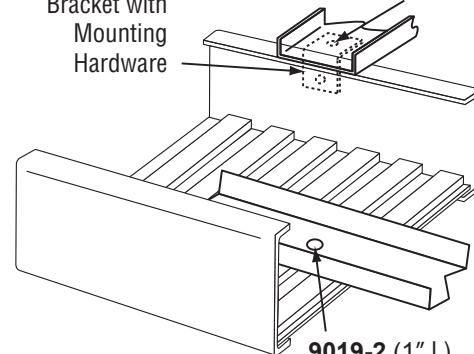

9019-2 (1" L)

5/16" Dia.

Bolt, Nut & Washer

## HANGERS

### Channel Hangers

For 3"-, 4"- or 6"- wide AB-Cope Channel raceways. Pipe sleeve accommodates either  $\frac{3}{8}$ " or  $\frac{1}{2}$ " diameter rods. Finish is hot-dip galvanized after fabrication. Order hardware separately.

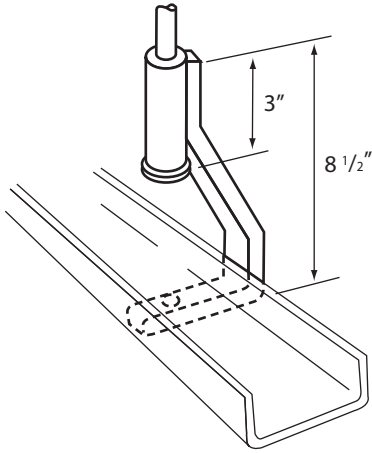

**SINGLE CHANNEL HANGER**

| Catalog No. | Use With              |
|-------------|-----------------------|
| 9013        | 3"- & 4"-wide channel |
| 9013-1      | 6"-wide channel       |

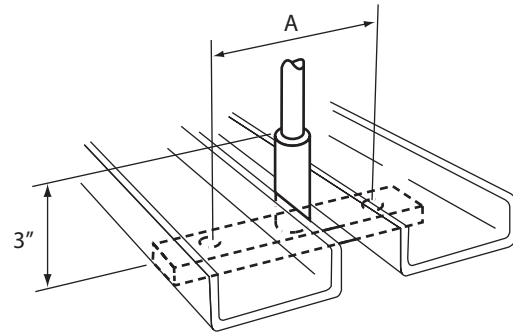

**DOUBLE CHANNEL HANGER**

| Catalog No. | Use With              | Dimension "A" |
|-------------|-----------------------|---------------|
| 9014        | 3"- & 4"-wide channel | 5"            |
| 9014-1      | 6"-wide channel       | 7"            |



# AB-COPE-GLAS

# 8

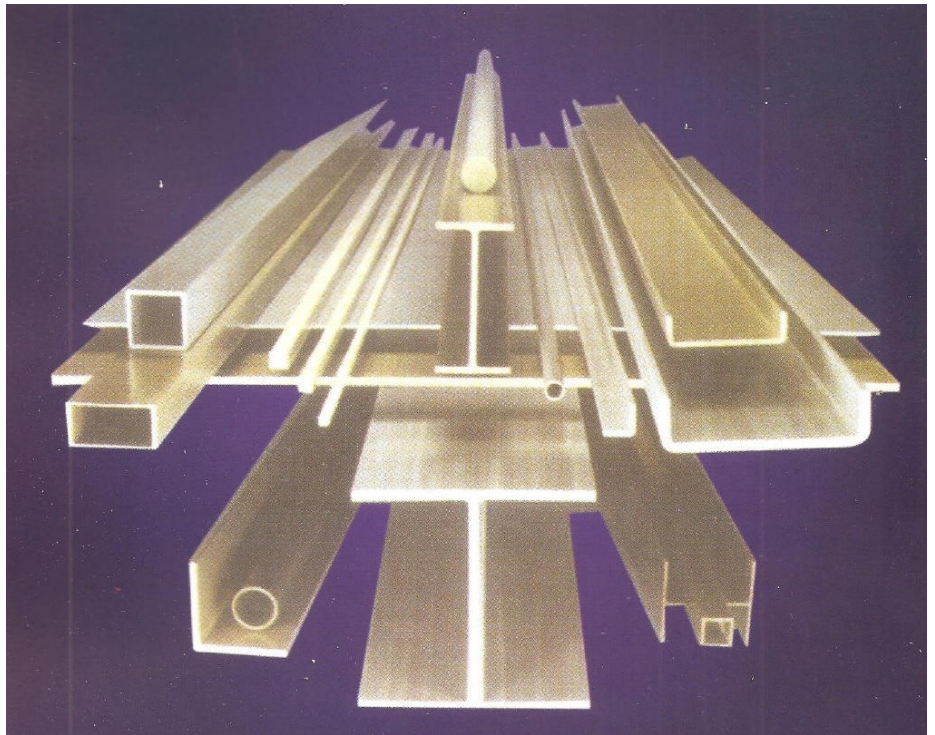

**Fiberglass Cable Tray System**

## TABLE OF CONTENTS

### General and Technical Information

|   |           |
|---|-----------|
| Advantages of AB-COPE-GLAS Cable Tray ..... | 185 - 186 |
| Fiberglass Cable Tray Standards .....       | 187       |
| AB-COPE-GLAS Cable Tray .....               | 188       |

### Cable Tray Design and Application

|   |           |
|---|-----------|
| Construction and Physical Properties..... | 189 - 190 |
| Application Environments .....            | 191 - 192 |
| AB-COPE-GLAS Selection Guide .....        | 193       |
| Installation Procedures .....             | 194       |

### Product Information

|   |           |
|---|-----------|
| Straight Sections .....   | 197 - 201 |
| Horizontal Elbow.....   | 202       |
| Vertical Elbows (Inside and<br>Outside) .....                                 | 203       |
| Straight Reducer, Right Left Reducer, Horizontal tee, horizontal cross, ..... | 204       |
| Mitered Fittings.....   | 205-208   |
| Cover Clamps.....   | 209-210   |
| Splice Plates.....  | 211-213   |
| Barrier Strips, Hold Down Clamps, Blind End.....                              | 214       |
| Drop Out.....   | 215       |
| Channal Type Trays.....   | 216-228   |
| Wire Way System.....  | 229-233   |

## AB-COPE-GLAS CABLE TRAY

AB-Cope-Glas Fiberglass Cable Tray as manufactured by AB-COPE-GLAS a division of AB-COPE metal products.

the rigid standards Furthermore, ensures the customer that the product they receive will meet the required FG1 performance criteria in the following areas:

- **Low Temperature**
- **High Temperature**
- **Flame resistance**
- **Loading & Deflection**
- **Dielectric Strength**
- **Volume Resistivity**
- **Thermogravimetric Analysis**
- **Infrared Analysis**
- **UV Exposure**
- **Water Exposure & Immersion**

In order to maintain the standard, AB-COPE must continually undergo follow-up testing with Laboratories. This further assures the customer that AB-COPE is maintaining its quality with respect to raw materials, production and fabrication. This practice demonstrates AB-COPE'S commitment to developing and providing its customers with the highest quality fiberglass cable tray products available in the industry.

## Straight Length

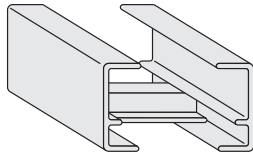

## Covers

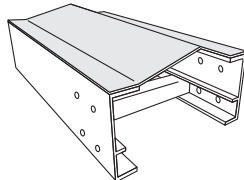

## Vertical Bends (Inside & Outside)

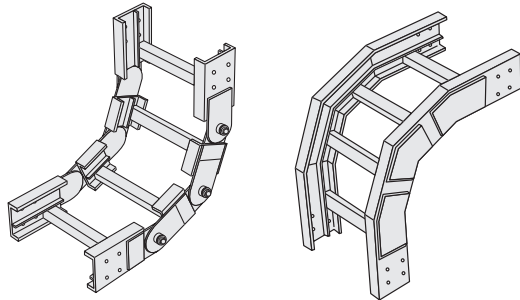

## Vertical Tees

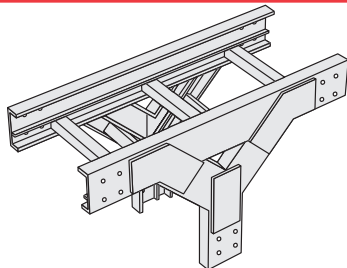

## Horizontal Elbows

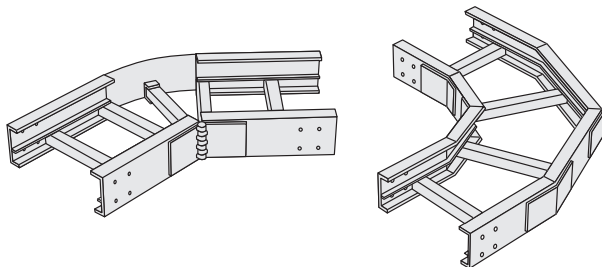

## Horizontal Tees

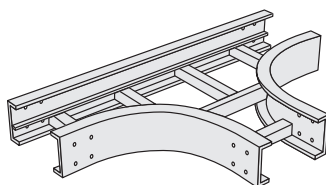

## Horizontal Cross

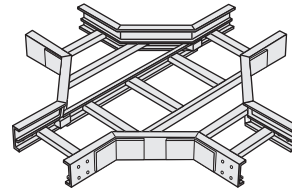

## Reducers

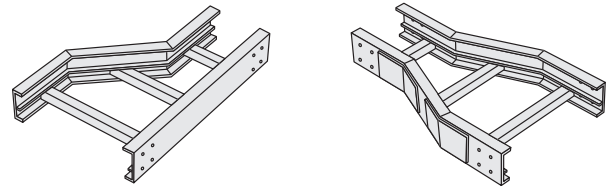

## Splice Plates

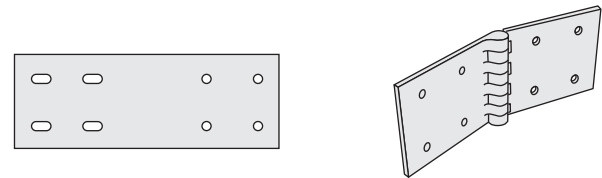

## Accessories

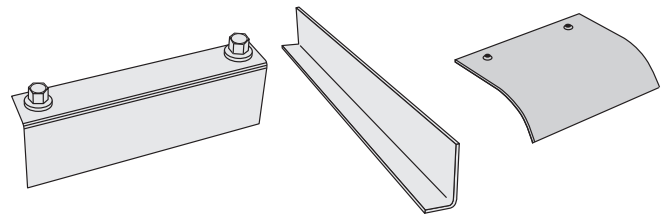

## Aickinstrut Support System

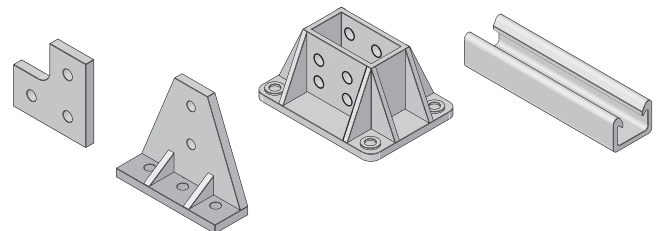

## Cope Fiberglass Channel System

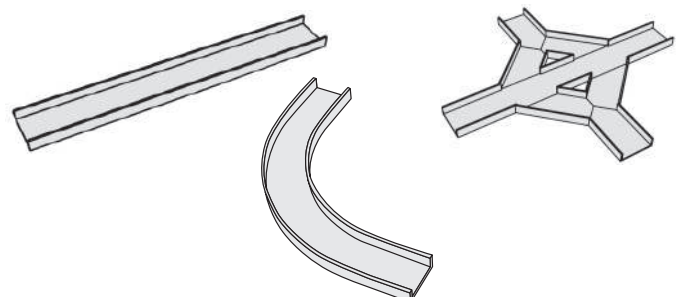

## ADVANTAGES OF AB-COPE-GLAS CABLE TRAY

### AB-COPE-GLAS Systems Advantages

Engineers, designers, contractors, installers and end users have many reasons to choose AB-COPE-GLAS cable tray for their power, signal and control distribution support requirements. Here are some specific advantages that AB-COPE-GLAS systems provide:

#### Corrosion Resistance

The inherent chemical resistance of AB-COPE-GLAS cable tray makes it desirable for severely corrosive environments. Life cycle costs of tray installations can be dramatically reduced by the extended life expectancy of this product. Many original installations have been in service for nearly fifteen years and are providing reliable service.

#### Versatile

AB-COPE-GLAS cable tray systems are available in a variety of sizes and styles. A standard or special design can be fabricated for any indoor or outdoor application regardless of size.

#### Easy Installation

AB-COPE-GLAS cable tray is strong and lightweight, allowing this durable system to be installed quickly and easily. Because there are no sharp edges or burrs, long runs of armored cable can be installed with less chance for cable damage.

---

### Tray System Advantages Over Other Wiring Methods

Cable tray systems in general provide the following advantages over other wiring methods:

#### Full Ventilation

Power cables need not be derated in a ventilated cable tray system. Explosive gases cannot be trapped or transmitted as in totally enclosed wiring systems.

#### Space Efficiency

AB-COPE-GLAS cable tray systems can carry more cable in less space than other wiring methods.

#### Simple Field Modifications

Modifications can be made easily using standard metalworking tools without extensive re-engineering.

#### Long Support Spans

AB-COPE-GLAS cable tray systems are designed for up to twenty foot support spans, longer than most other wiring methods. Fewer supports reduce both installation time and cost.

#### Fully Compatible with Other Wiring Methods

AB-COPE-GLAS cable tray is often used in main runs when other wiring methods are employed in branch circuits.

#### Accessibility for the Future

New cable can be easily added, replaced or repaired. Circuits can be visually traced, minimizing startup and trouble shooting.

#### Installation Labor Reduced

AB-COPE-GLAS cable tray can be installed after concrete and major building steel and mechanical piping are complete. Crews can start later and finish sooner.

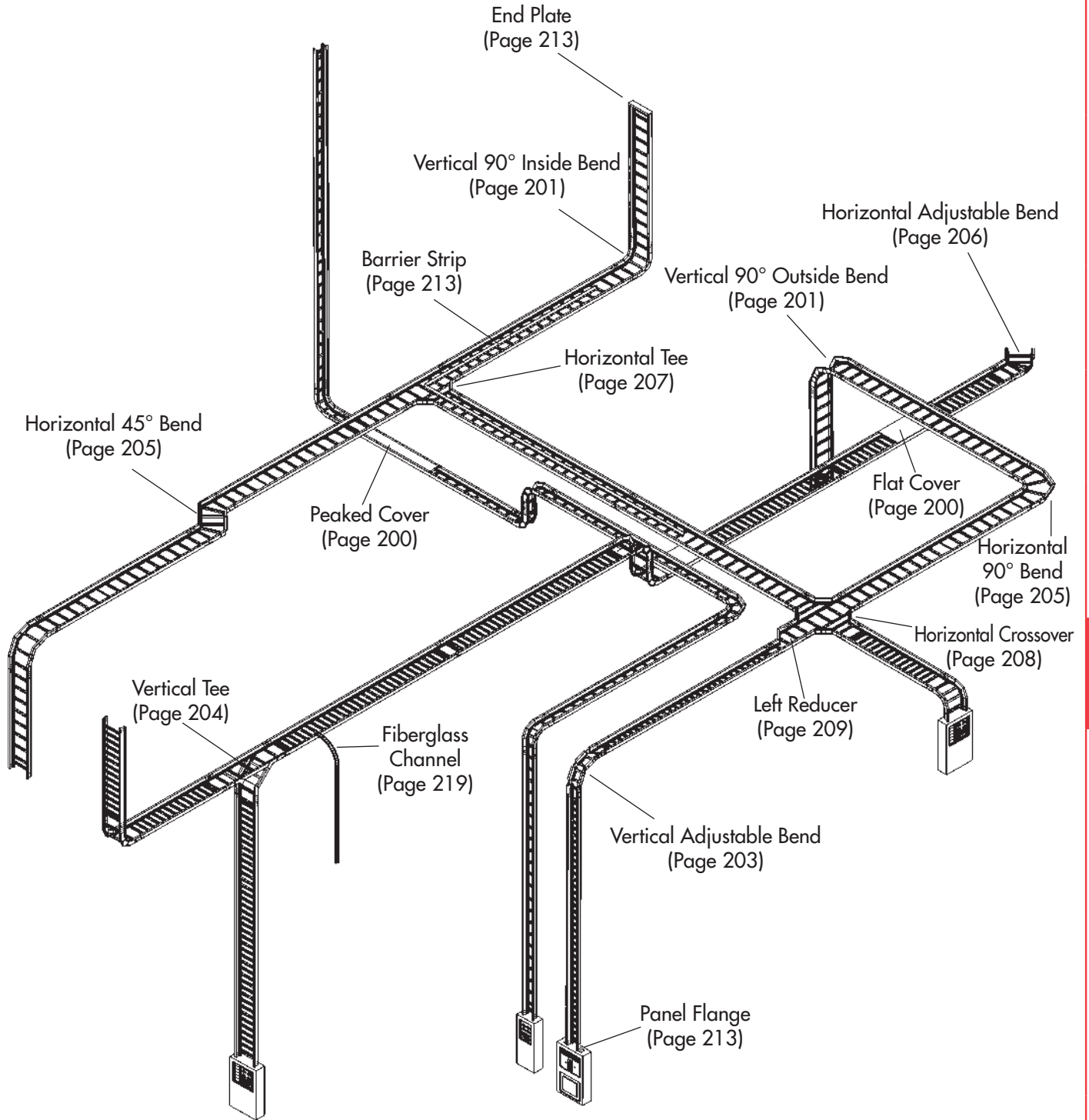

## STANDARDS

The standards commonly referenced in specifying cable tray are the National Electric Code®, Article 392-Cable trays; NEMA Standards Publication NO. FG 1, Fiberglass Cable Tray Systems; Canadian Standards Association  
CAN/CSA-C22.2 No. 126-M91, Cable Tray Systems and Underwriters Laboratories Inc. Standard UL-568, CYOV Non-Metallic Cable Trays. ASTM and UL standards are also referenced to characterize the materials used to construct the fiberglass cable tray.

ASTM standards define physical properties tests for the materials used to pultrude the cable tray. The specific ASTM test methods for mechanical, thermal and flammability properties are identified in the Construction and Physical Properties Section. UL flammability standards applied to fiberglass cable tray materials are also identified in the same section. ASTM and UL standard material properties for fiberglass channel and strut are identical to those of the cable tray because they are pultruded from the same materials.

### Load Standards

Section 3 of NEMA FG 1 provides the performance standards and class designations for fiberglass cable tray systems. Based on a twenty foot support span, three working load classifications are recognized:

| Load Class | Allowable Working Load |
|------------|------------------------|
| A          | 50 lbs./linear ft.     |
| B          | 75 lbs./linear ft.     |
| C          | 100 lbs./linear ft.    |

All AB-COPE-GLAS tray styles have a 1.5 safety factor and exceed the NEMA FG 1 requirement for the allowable working load.

### Considerations for Cable Tray Deflection

Cable Tray load testing as specified by NEMA Standard FG 1 requires the test article to be a single length of tray simply supported at each end (referred to as a "simple beam" configuration - see diagram below). This requirement was established to standardize testing and because it is impractical to test large tray system assemblies to destruction. Most actual tray installations consist of multiple lengths of connected tray with multiple supports (referred to as a "continuous beam" configuration). The most significant difference between a continuous versus simple beam configuration is that for continuous beam, the presence of adjacent lengths of tray affect the deflection of the tray in the section of interest.

With the same loading and support span, the maximum deflection is dramatically less for continuous compared to simple beam.

### Tray Splice Joint Locations vs. Support Locations

In a continuous beam configuration, the bending moment in the tray side rails becomes zero at points located approximately 1/4 of the span from each tray support (referred to as "quarter span points" or just "quarter points"). For example, if the support span is 10 feet, the quarter point is 2.5 feet from the support. Quarter points are ideal locations for spliced tray connections because joints are subjected to minimum bending stresses (see diagram below).

### Effect of Temperature

When continuously exposed to elevated temperatures, the strength properties of reinforced fiberglass are reduced. Working loads shall be reduced based on the following table.

| Temp. in °F | Approximate % of Strength |                   |
|-------------|---------------------------|-------------------|
|             | Polyester Resin           | Vinyl Ester Resin |
| 75°         | 100                       | 100               |
| 100°        | 90                        | 100               |
| 125°        | 78                        | 100               |
| 150°        | 68                        | 90                |
| 175°        | 60                        | 90                |
| 200°        | 52                        | 75                |

Note: Consult the manufacturer when temperatures above 200° F are encountered. AB-Cope-Glas is not adversely affected by below freezing temperatures.

### Chemical Resistance

In most applications, fiberglass cable tray is used because of its superior corrosion resistance; therefore, corrosion resistance data for specific environments are very important. The corrosion resistance guide in the Application Environments Section offers performance data in the most common environments. If information for a specific environment is not shown in the guide, please consult the factory.

### Installation/Application

Guidance for cable tray installation, supports and support locations and thermal expansion/contraction is provided in NEMA FG 1. The installation instructions for supports and support locations contained in the Installation Procedures Section of this catalog are based on the Application Information Section of NEMA FG 1.

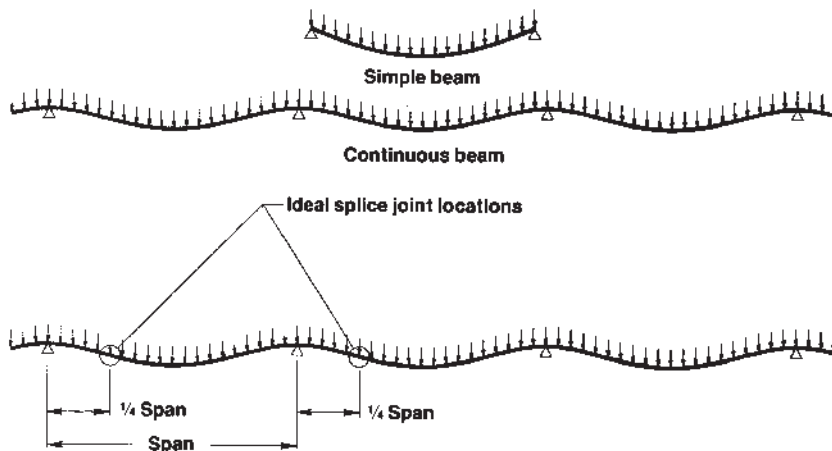

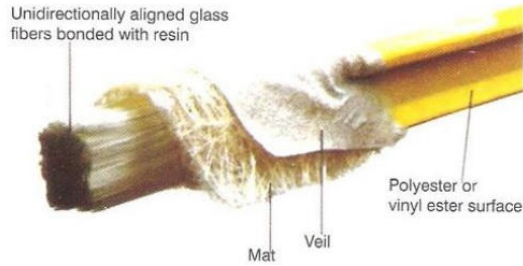

**AB.Cope** GRP profiles are designed and manufactured as structural components. It is, therefore, essential to control the position and orientation of the glass fiber reinforcement to maintain their structural integrity. In addition, the corrosion resistance is influenced by the efficiency of the bond between the fiber and the resin.

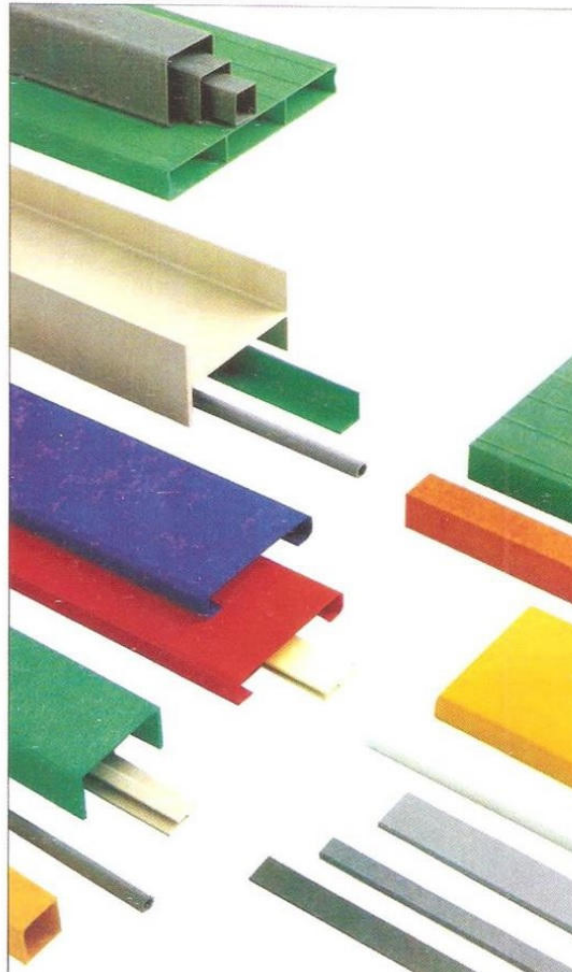

## CONSTRUCTION AND PHYSICAL PROPERTIES

### The Pultrusion Process

The pultruded structural component is made by reinforcing a polymer resin (usually polyester or vinyl ester resin) with multiple strands of glass filament and alternating layers of glass mat.

The glass is drawn through the liquid resin, which coats and saturates the fibers. The combination of resin and glass is then continuously guided and pulled (pultruded) through a heated die that determines the shape of the component.

In the die, the resin is cured to form a permanent, reinforced part which can be cut to a specific length. Since the hardened fiberglass pultrusion is reinforced with an internal arrangement of permanently bonded continuous glass fibers, it possesses great strength. In addition to strength, pultruded fiberglass components exhibit exceptional corrosion resistance. This attribute makes fiberglass the material of choice for many harsh industrial applications.

### Resin Systems

Polyester and vinyl ester resin systems are available. The vinyl ester resin system is somewhat stronger and is applied in severe corrosive applications.

Both resin systems are flame retardant, conforming to ASTM E84, Class 1 flame rating and are self extinguishing per the requirements of UL94V-0.

Consult the corrosion resistance guide on pages 191 - 192 to determine the correct resin system for your application.

### Low Smoke Resin Systems

Increasingly stringent standards regarding flame retardancy and smoke and fume emissions have necessitated the development of alternatives to standard polyester and vinyl ester resin systems. One of these alternatives, Modified Acrylic Resin (MODAR®), offers comparable or superior physical/mechanical properties plus low smoke and fume emissions. MODAR®

resin cable tray provides the following advantages over polyester and vinyl ester tray:

- Excellent flame retardancy
- Low smoke emissions
- Low levels of toxic combustion products

MODAR® cable tray meets the following specifications:

| Test Method                    | Result                             |
|--------------------------------|------------------------------------|
| ASTM E-84                      | < 25                               |
| ASTM E-162<br>radiant panel    | 10<br>@1.5 minutes = 5             |
| ASTM E-662<br>smoke generation | @4.0 minutes = 50<br>maximum = 200 |
| UL94                           | V-0                                |

Contact the factory for additional information regarding pricing and availability.

| Typical Properties                  | Typical Value<br>Test Method | Typical Value<br>Direction | Unit        | Polyester             | Vinyl Ester           |
|-------------------------------------|------------------------------|----------------------------|-------------|-----------------------|-----------------------|
| <b>Mechanical</b>                   |                              |                            |             |                       |                       |
| Ultimate Tensile Strength           | ASTM D-638                   | Longitudinal               | PSI         | 30,000                | 35,000                |
|                                     | ASTM D-638                   | Transverse                 | PSI         | 7,000                 | 10,000                |
| Tensile Modulus                     | ASTM D-638                   | Longitudinal               | PSI         | 2.5 x 10 <sup>6</sup> | 3.0 x 10 <sup>6</sup> |
|                                     | ASTM D-638                   | Transverse                 | PSI         | 0.8 x 10 <sup>6</sup> | 1.0 x 10 <sup>6</sup> |
| Ultimate Compressive Strength       | ASTM D-695                   | Longitudinal               | PSI         | 30,000                | 35,000                |
|                                     | ASTM D-695                   | Transverse                 | PSI         | 15,000                | 20,000                |
| Compressive Modulus                 | ASTM D-695                   | Longitudinal               | PSI         | 2.5 x 10 <sup>6</sup> | 2.5 x 10 <sup>6</sup> |
|                                     | ASTM D-695                   | Transverse                 | PSI         | 1.0 x 10 <sup>6</sup> | 1.2 x 10 <sup>6</sup> |
| Ultimate Flexural Strength          | ASTM D-790                   | Longitudinal               | PSI         | 30,000                | 35,000                |
|                                     | ASTM D-790                   | Transverse                 | PSI         | 10,000                | 14,000                |
| Flexural Modulus                    | ASTM D-790                   | Longitudinal               | PSI         | 1.6 x 10 <sup>6</sup> | 2.0 x 10 <sup>6</sup> |
|                                     | ASTM D-790                   | Transverse                 | PSI         | 0.8 x 10 <sup>6</sup> | 1.0 x 10 <sup>6</sup> |
| Shear Strength Short Beam           | ASTM D-2344                  | Longitudinal or            | PSI         | 5,500                 | 7,000                 |
|                                     |                              | Transverse                 | PSI         | 5,500                 | 6,000                 |
| Impact Strength-Izod                | ASTM D-256                   | Longitudinal               | ft.-lb./in. | 25                    | 30                    |
|                                     |                              | Transverse                 | ft.-lb./in. | 4                     | 5                     |
| Hardness-Barcol                     | ASTM D-2583                  | Perpendicular              |             | 50                    | 50                    |
| <b>Electrical</b>                   |                              |                            |             |                       |                       |
| Electric Strength Short Time-in oil | ASTM D-149                   | Perpendicular              | Volts/mil.  | 200                   | 200                   |
|                                     |                              | Parallel                   | KV/in.      | 35                    | 35                    |
| Dielectric Constant                 | ASTM D-150                   | Perpendicular              |             | 5.0                   | 5.0                   |
| Dissipation Factor                  | ASTM D-150                   | Perpendicular              |             | 0.03                  | 0.03                  |
| Arc Resistance                      | ASTM D-495                   | Longitudinal or            | Seconds     | 80                    | 120                   |
|                                     |                              | Transverse                 | Seconds     | 80                    | 120                   |

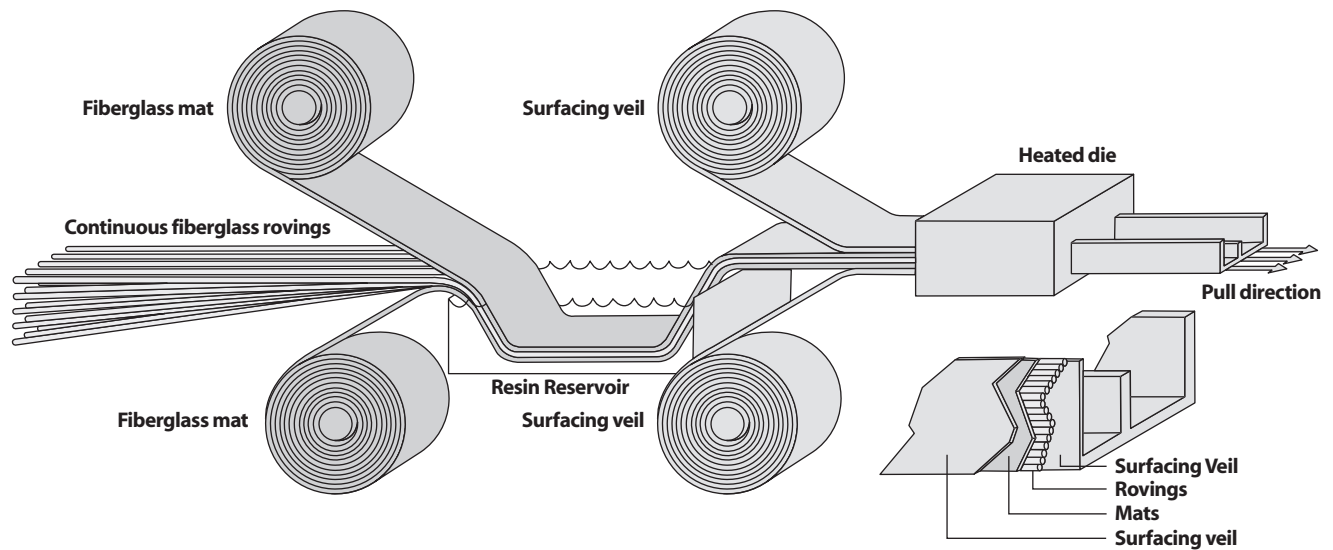

### AB-COPE-GLAS Material Properties (Continued from previous page)

Glass Roving and Mat Reinforced Polyester and Vinyl Ester Fiberglass Components

| Typical Properties               | Test Method | Direction    | Unit                   | Typical Value Polyester | Typical Value Vinyl Ester |
|----------------------------------|-------------|--------------|------------------------|-------------------------|---------------------------|
| <b>Other</b>                     |             |              |                        |                         |                           |
| Thermal Coefficient of Expansion | ASTM D-696  | Longitudinal | in./in./°F             | $5 \times 10^{-6}$      | $5 \times 10^{-6}$        |
| Thermal Conductivity             |             | Longitudinal | BTU/Hr. sq. ft./in./°F | 4.0                     | 4.0                       |
| Water Absorption 24 hours        | ASTM 0-570  | Longitudinal | %                      | 1                       | 1                         |
| Density                          | ASTM D-792  | Longitudinal | lbs./cu.in.            | 0.062                   | 0.062                     |
| Color (Standard)                 |             |              |                        | Dark Gray               | Beige                     |
| Flammability                     | UL94        |              | Classification:        | V-0                     | V-0                       |
| Flammability                     | ASTME84     |              | Rating:                | 25                      | 25                        |

The foregoing list of properties was derived from laboratory data using coupon test specimens cut from pultruded sections. Such information should only be used as a general guide in design. Many actual components (such as cable tray side rail) take advantage of the flexibility of the pultrusion process and are selectively reinforced to enhance performance in a particular load axis. The factory should be contacted for specific information on any given component.

### Aickinstruct Fiberglass Threaded Rod Material Properties

Threaded rod is a proprietary combination of fiberglass and Class I vinyl ester flame retardant resin.

| Properties  | 3/8-16 UNC                     | 1/2-13 UNC         | 5/8-11 UNC         |
|---|--------------------------------|--------------------|--------------------|
| Thread shear strength using fiberglass nut in tensile (lbs.)                                  | 1,250                          | 2,500              | 3,800              |
| Transverse shear on threaded rod-double shear ASTM-B-565 (load lb.)                           | 4,200                          | 7,400              | 11,600             |
| Transverse shear on threaded rod-single shear (load lb.)                                      | 1,600                          | 2,600              | 3,800              |
| Compressive strength-longitudinal ASTM-D-695 (psi)  | 55,000                         | 55,000             | 55,000             |
| Flexural strength ASTM-D-790 (psi)  | 60,000                         | 60,000             | 60,000             |
| Flexural modulus ASTM-D-790 (psi x 10 <sup>6</sup> )  | $2.0 \times 10^6$              | $2.0 \times 10^6$  | $2.0 \times 10^6$  |
| Torque strength using fiberglass nut lubricated with SAE IOW30 motor oil (ft./lbs.)           | 8                              | 15                 | 33                 |
| Dielectric strength ASTM-D-149 (kv/in.)   | 40                             | 40                 | 40                 |
| Water absorption 24 hour immersion-threaded ASTM-D-570 (%)                                    | 1                              | 1                  | 1                  |
| Coefficient of thermal expansion-longitudinal (in./in./°F)                                    | $5 \times 10^{-6}$             | $5 \times 10^{-6}$ | $5 \times 10^{-6}$ |
| Max recommended operation temp, based on 50% retention of ultimate thread shear strength (°F) | 200                            | 200                | 200                |
| Stud weight (lb./ft.)   | .076                           | .129               | .209               |
| Flammability  | Self extinguishing per UL94V-0 |                    |                    |

## APPLICATION ENVIRONMENTS

### Corrosion Resistance

In most applications AB-COPE-GLAS cable tray is used because of its superior corrosion resistance. The following corrosion resistance guide offers performance recommendations for the most common environments.

Additional data for less common environments are also available from the factory.

### Corrosion Resistance Guide

The general guidelines presented in this table take into consideration the normal applications of cable tray products and accessories where exposure to harsh chemicals is limited to fumes or vapors and occasional splashes at ambient temperatures. This information is provided as a guide only since it is impossible to anticipate every conceivable application. For specific applications, which may fall outside the scope of these guidelines, it is recommended that the factory be consulted directly.

Special applications may require a screening test of material samples in the chemical environment of interest.

#### Notes:

- S** - indicates satisfactory performance.
- NR** - indicates not recommended for use. However, acceptable performance may be provided if fumes are not highly concentrated.
- NA** - indicates information not available.

| Chemical Environment       | AB-COPE-GLAS Performance |             |
|----------------------------|--------------------------|-------------|
|                            | Poly-ester               | Vinyl Ester |
| Acetic Acid                | S                        | S           |
| Acetone                    | NR                       | NR          |
| Acrylic Acid               | NR                       | S           |
| Aluminum Chloride          | S                        | S           |
| Aluminum Chlorohydroxide   | S                        | S           |
| Aluminum Citrate           | S                        | S           |
| Aluminum Hydroxide         | S                        | S           |
| Aluminum Nitrate           | S                        | S           |
| Aluminum Potassium Sulfate | S                        | S           |
| Aluminum Sulfate           | S                        | S           |
| Ammonia, dry gas           | S                        | S           |
| Ammonia, liquid            | NR                       | NR          |
| Ammonium Acetate           | NR                       | S           |
| Ammonium Carbonate         | NR                       | S           |
| Ammonium Chloride          | S                        | S           |
| Ammonium Citrate           | S                        | S           |
| Ammonium Hydroxide         | NR                       | S           |
| Ammonium Nitrate           | S                        | S           |
| Ammonium Phosphate         | S                        | S           |
| Ammonium Sulfate           | S                        | S           |
| Ammonium Sulfide           | NR                       | NA          |
| Ammonium Sulfite           | NR                       | S           |
| Ammonium Thiosulfate       | NR                       | S           |
| Amyl Acetate               | NR                       | NR          |
| Amyl Alcohol               | S                        | S           |
| Amyl Chloride              | NR                       | NA          |
| Aniline Sulfate            | S                        | S           |
| Barium Acetate             | S                        | S           |
| Barium Carbonate           | S                        | S           |
| Barium Chloride            | S                        | S           |
| Barium Sulfate             | S                        | S           |
| Benzene                    | S                        | NR          |
| Benzoic Acid               | S                        | S           |
| Benzyl Alcohol             | NR                       | NR          |
| Borax                      | S                        | S           |
| Boric Acid                 | S                        | S           |
| Brine                      | S                        | S           |
| Bromine, dry gas           | NR                       | S           |
| Bromine, wet gas           | NR                       | S           |
| Bromine, liquid            | NR                       | NR          |
| Butyl Acetate              | NR                       | NR          |
| Butyl Alcohol, normal      | S                        | S           |
| Butyl Cellosolve           | S                        | NR          |
| Butylene Glycol            | S                        | S           |
| Butyric Acid               | S                        | S           |
| Calcium Bisulfite          | S                        | S           |
| Calcium Carbonate          | S                        | S           |
| Calcium Chlorate           | S                        | S           |
| Calcium Chloride           | S                        | S           |
| Calcium Nitrate            | S                        | S           |
| Calcium Sulfate            | S                        | S           |

| Chemical Environment  | AB-COPE-GLAS Performance |             |
|-----------------------|--------------------------|-------------|
|                       | Poly-ester               | Vinyl Ester |
| Caprylic Acid         | S                        | S           |
| Carbon Dioxide, gas   | S                        | S           |
| Carbon Disulfide      | NR                       | NR          |
| Carbonic Acid         | S                        | NA          |
| Carbon Monoxide, gas  | S                        | S           |
| Carbon Tetrachloride  | NR                       | NR          |
| Chloroacetic Acid     | NR                       | S           |
| Chlorinated Paraffin  | S                        | S           |
| Chlorine, dry gas     | S                        | S           |
| Chlorine, wet gas     | NR                       | S           |
| Chlorine, liquid      | NR                       | NR          |
| Chlorine Dioxide      | NR                       | S           |
| Chlorine Water        | S                        | S           |
| Chlorobenzene         | NR                       | NR          |
| Chromic Acid          | NR                       | S           |
| Chromous Sulfate      | S                        | S           |
| Citric Acid           | S                        | S           |
| Coconut Oil           | S                        | S           |
| Copper Acetate        | S                        | S           |
| Copper Chloride       | S                        | S           |
| Copper Cyanide        | S                        | S           |
| Copper Nitrate        | S                        | S           |
| Copper Sulfate        | S                        | S           |
| Cresylic Acid Fumes   | NR                       | NR          |
| Cresol                | NR                       | NA          |
| Crude Oil (Sour)      | S                        | S           |
| Cyclohexane           | NR                       | S           |
| Diallylphthalate      | S                        | S           |
| Diammonium Phosphate  | NR                       | S           |
| Dibutyl Ether         | NR                       | S           |
| Dibutyl Phthalate     | S                        | S           |
| Diesel Fuel           | S                        | S           |
| Diethylene Glycol     | S                        | S           |
| Dimethyl Phthalate    | NR                       | S           |
| Dimethyl Sulfoxide    | NR                       | NA          |
| Diphenyl Ether        | NR                       | S           |
| Dipropylene Glycol    | S                        | S           |
| Esters, Fatty Acid    | S                        | S           |
| Ethyl Alcohol         | NR                       | S           |
| Ethylene Chlorohydrin | NR                       | S           |
| Ethylene Glycol       | S                        | S           |
| Fatty Acids           | S                        | S           |
| Ferric Chloride       | S                        | S           |
| Ferric Nitrate        | S                        | S           |
| Ferric Sulfate        | S                        | S           |
| Ferrous Chloride      | S                        | S           |
| Ferrous Nitrate       | S                        | S           |
| Ferrous Sulfate       | S                        | S           |
| Fluoboric Acid        | S                        | S           |
| Fluosilicic Acid      | NR                       | S           |
| Formic Acid, vapor    | S                        | S           |

## APPLICATION ENVIRONMENTS

| Chemical Environment       | AB-COPE-GLAS Performance |             | Chemical Environment       | AB-COPE-GLAS Performance |             | Chemical Environment         | AB-COPE-GLAS Performance |             |
|----------------------------|--------------------------|-------------|----------------------------|--------------------------|-------------|------------------------------|--------------------------|-------------|
|                            | Poly-ester               | Vinyl Ester |                            | Poly-ester               | Vinyl Ester |                              | Poly-ester               | Vinyl Ester |
| Fuel Oil                   | S                        | S           | Olive Oils                 | S                        | S           | Sodium Nitrite               | S                        | S           |
| Furfural                   | NR                       | NR          | Oxalic Acid                | S                        | S           | Sodium Silicate, pH<12       | NR                       | S           |
| Gasoline, Aviation         | S                        | S           | Palmitic Acid              | S                        | S           | Sodium Silicate, pH>12       | NR                       | S           |
| Gasoline, Ethyl            | S                        | S           | Perchlorethylene           | NR                       | S           | Sodium Sulfate               | S                        | S           |
| Gluconic Acid              | S                        | S           | Perchloric Acid            | NR                       | S           | Sodium Sulfide               | NR                       | S           |
| Glucose                    | S                        | S           | Phenol                     | NR                       | NR          | Sodium Sulfite               | NR                       | S           |
| Glycerine                  | S                        | S           | Phosphoric Acid            | S                        | S           | Sodium Tetraborate           | S                        | S           |
| Hexachlorocyclopentadienl  | NR                       | NA          | Photographic Solutions     | S                        | NA          | Sodium Thiosulfate           | S                        | S           |
| Hydrochloric Acid          | S                        | S           | Phthalic Anhydride         | S                        | S           | Sodium Xylene Sulfonate      | NR                       | S           |
| Hydrofluoric Acid          | NR                       |             | Pickling Liquids, Acid     | S                        | S           | Sorbitol Solutions           | S                        | S           |
| Hydrogen Bromide, dry gas  | S                        | S           | Pickling Liquids, Alkaline | NR                       | NA          | Sour Crude Oil               | S                        | S           |
| Hydrogen Chloride, dry gas | S                        | S           | Picric Acids               | NR                       | NA          | Soya Oil                     | S                        | S           |
| Hydrogen Chloride, wet gas | S                        | S           | Potassium Aluminum Sulfate | S                        | S           | Stannous Chloride            | S                        | S           |
| Hydrogen Fluoride, vapor   | NR                       | S           | Potassium Bicarbonate      | S                        | S           | Stearic Acid                 | S                        | S           |
| Hydrogen Peroxide          | NR                       | S           | Potassium Bromide          | S                        | S           | Styrene                      | NR                       | NR          |
| Hydrogen Sulfide, dry gas  | S                        | S           | Potassium Carbonate        | NR                       | S           | Sulfated Detergents          | S                        | S           |
| Hydrogen Sulfide, wet gas  | S                        | S           | Potassium Chloride         | S                        | S           | Sulfonated Detergents        | NR                       | S           |
| Hydroiodic Acid            | NR                       | NA          | Potassium Ferricyanide     | S                        | S           | Sulfonyl Chloride, Aromatic  | NR                       | NA          |
| Hypochlorous Acid          | NR                       | S           | Potassium Ferrocyanide     | S                        | S           | Sulfur Dioxide, dry gas      | S                        | S           |
| sodecanol                  | S                        | S           | Potassium Hydroxide        | NR                       | S           | Sulfur Dioxide, wet gas      | S                        | S           |
| Isopropyl Palmitate        | S                        | S           | Potassium Nitrate          | S                        | S           | Sulfuric Acid, vapor         | S                        | S           |
| Jet Fuel (JP-4)            | S                        | S           | Potassium Permanganate     | NR                       | S           | Sulfurous Acid               | NR                       | S           |
| Kerosene                   | S                        | S           | Potassium Persulfate       | NR                       | S           | Tannic Acid                  | S                        | S           |
| Lactic Acid                | S                        | S           | Potassium Sulfate          | S                        | S           | Tartaric Acid                | S                        | S           |
| Lead Acetate               | S                        | S           | Propylene Glycol           | S                        | S           | Tetrachloroethylene          | NR                       | S           |
| Lime Slurry                | S                        | S           | Silicic Acid               | S                        | NA          | Tetrapotassium               |                          |             |
| Linseed Oil                | S                        | S           | Silver Nitrate             | S                        | S           | Pyrophosphate                | NR                       | S           |
| Lithium Bromide            | S                        | S           | Sodium Acetate             | S                        | S           | Tetrasodium Pyrophosphate    | NR                       | S           |
| Lithium Chloride           | S                        | S           | Sodium Benzoate            | S                        | S           | Toulene                      | NR                       | S           |
| Magnesium Bicarbonate      | S                        | S           | Sodium Bicarbonate         |                          |             | Toluene Di-isocyanate fumes  | NR                       | NA          |
| Magnesium Carbonate        | S                        | S           | Saturated                  | S                        | S           | Trichlorethylene, fumes      | NR                       | NR          |
| Magnesium Chloride         | S                        | S           | Sodium Bisulfate           | S                        | S           | Trichloroacetic Acid         | NR                       | S           |
| Magnesium Nitrate          | S                        | S           | Sodium Borate              | S                        | S           | Trimethylamine Hydrochloride | S                        | S           |
| Magnesium Sulfate          | S                        | S           | Sodium Bromide             | S                        | S           | Triphenyl Phosphite          | NR                       | S           |
| Mercuric Chloride          | S                        | S           | Sodium Carbonate           | NR                       | S           | Trisodium Phosphate          | NR                       | S           |
| Mercurous Chloride         | S                        | S           | Sodium Chlorate            | NR                       | S           | Turpentine, Pure Gum         | NR                       | S           |
| Mercury                    | S                        | S           | Sodium Chloride            | S                        | S           | Urea                         | S                        | S           |
| Methyl Alcohol             | S                        | NR          | Sodium Chloride            |                          |             | Vinegar                      | S                        | S           |
| Methyl Ethyl Ketone        | NR                       | NR          | Saturated Chlorine         | NR                       | S           | Water, Cooling Tower         | S                        | S           |
| Milk Waste                 | S                        | S           | Sodium Chlorite            | NR                       | S           | Water, Demineralized         | S                        | S           |
| Mineral Oils               | S                        | S           | Sodium Cyanide             | S                        | S           | Water, Distilled             | S                        | S           |
| Monochlorobenzene          | NR                       | NR          | Sodium Dichromate          | NR                       | S           | Water, Mine                  | S                        | S           |
| Naptha                     | S                        | S           | Sodium Di-phosphate        | S                        | S           | Water, Sea                   | S                        | S           |
| Napthalene                 | S                        | S           | Sodium Ferricyanide        | S                        | S           | Water, Steam Condensate      | S                        | S           |
| Nickel Chloride            | S                        | S           | Sodium Ferrocyanide        | S                        | S           | Water, Tap                   | S                        | S           |
| Nickel Nitrate             | S                        | S           | Sodium Fluoride            | NR                       | S           | Xylene                       | NR                       | S           |
| Nickel Sulfate             | S                        | S           | Sodium Hydroxide           | NR                       | S           | Zinc Chloride                | S                        | S           |
| Nickel Sulfonate Plating   |                          |             | Sodium Hypochlorite        | NR                       | S           | Zinc Nitrate                 | S                        | S           |
| Solution                   | S                        | S           | Sodium Hyposulfite         | S                        | NA          | Zinc Sulfate                 | S                        | S           |
| Nitric Acid                | NR                       | S           | Sodium Mono-phosphate      | S                        | S           |                              |                          |             |
| Oleic Acid                 | S                        | S           | Sodium Nitrate             | S                        | S           |                              |                          |             |

## Selection Guide

Several criteria must be considered in selecting AB-COPE-GLAS cable tray for your application. Factors include load capacity and safety factor; support spans; deflection; cable diameter and tray fill capacity; application environment; space restrictions; fire resistance; future expansion and cost.

Article 392 of the National Electric Code provides cable size and cable fill information. NEMA Standards Publication No. FG 1, Fiberglass Cable Tray Systems, specifies manufacturing standards, performance standards, load class designation specifications and application information such as support span guidelines and temperature deflection information.

The following guidelines will assist you in your selection of AB-COPE-GLAS cable tray:

### Step 1:

Determine the resin system required based on the application, location, and environment (consult the corrosion resistance guide in the Application Environments section). AB-COPE-GLAS cable tray is available in polyester and vinyl ester resin systems. Vinyl ester provides more corrosion resistance than polyester in some environments.

### Step 2 :

Determine tray loading depth and width. Depending on the size and number of cables needed, use the guidelines in NEC Article 392-8 through -12 to determine tray loading depth and width.

### Step 3 :

Determine rung spacing. The smallest cable or wire bundle determines the rung spacing for ladder type trays. In general, use eighteen inch rung spacing for 2" O.C. or larger, nine or twelve inch rung spacing for cables from 1" to 2" O.D., six inch run spacing for cables from 1/2" to 1" O.D. and fiberglass channel type trays for smaller cables.

### Step 4 :

Determine the cable load. Calculate in pounds per linear foot the load of the cables to be supported. Consider any extraneous loads such as ice, snow, wind, etc. and add this value to the cable load.

### Step 5 :

Determine the tray style. AB-COPE-GLAS offers

### Step 6 :

Determine the support spacing. Normally, cable tray systems are supported at eight foot to twenty foot intervals. Tray may be supported by wall mount brackets, trapeze suspensions, supports from existing structures or it may be floor mounted to minimize deflection.

Splice joints should be placed at or near the quarter point of the span. This guideline should be rigidly followed and non-compliance granted only after careful engineering analysis because of high cable tray stresses which can be generated.

### Step 7:

Determine the NEMA or CSA load class. The cable tray system should be determined by the combination of cable load (Step 4) and support spacing (Step 5). Consult the Structural Design section of this catalog or NEMA FG 1 to assist you in the selection of a tray system that meets your requirements.

| NEMA Class | Working Load*     |
|------------|-------------------|
| A          | 50 lbs./lin. ft.  |
| B          | 75 lbs./lin. ft.  |
| C          | 100 lbs./lin. ft. |

\* Working load classifications based on 20 foot support spans. Chart not applicable for channel tray.

The following information shall be used as a guideline for installing AB-COPE-GLAS cable tray.

### Special Considerations

With few exceptions, the installation of fiberglass cable tray does not differ from that of metal tray. All standard installation practices and procedures apply. In general, special handling is not required.

### Tools Required

Fiberglass tray is easy to cut and drill. For most installations, standard tools are sufficient; however, for large jobs where many sections require cutting and drilling, high speed steel tools may become dull due to the abrasiveness of glass. In such installations, the use of carbide tipped drills and abrasive (grit) saw blades is recommended.

### Cutting Tray in the Field

Tray may be easily cut in the field using a standard hacksaw. If some type of power saw is used, abrasive grit-blades work best. When using a power saw, dust filter masks should be worn. Gloves and long sleeve clothing are also recommended.

### Sealing Edges

All cut edges should be sealed with FIBER-SEAL, AB-COPE-GLASS sealant compound. FIBER-SEAL is clear, dries fast and is easy to use. In harsh environments, proper sealing insures against future migration of corrosive elements into the cut sections.

### Drilling Holes for Splice Plates

When drilling holes for splice plates, a  $1\frac{3}{32}$ " drill bit will provide a properly sized hole. Clamp a splice plate (using a C-clamp) to the side of the tray and use this plate as a drilling template. The plate should be positioned to allow a  $\frac{1}{16}$ " gap between joined side rails or fittings.

### Use of Encapsulated Hardware

Tray sections should be joined using AB-COPE-GLAS fiberglass encapsulated stainless steel nuts and bolts. For maximum protection in extremely harsh environments, apply a generous amount of FIBER-SEAL to the nut and bolt (inside surfaces and threads) just prior to assembly. Assembled splice joints should be tightened to approximately 12 ft./lbs.

### Locating Splice Joints

When possible, splice joints should be placed at or near the quarter point of any given support span. This is the point of least mechanical stress. For example: with a section of tray resting on supports spaced 20 feet apart, the splice plate joints should be located 5 feet from supports (support span divided by 4).

Splice plate joints should be located as close as possible to the quarter point of the support span

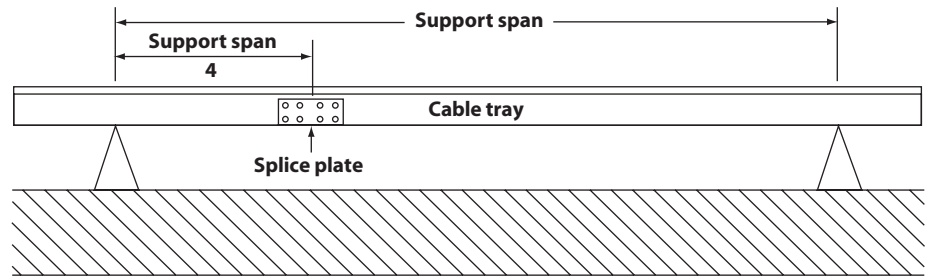

### Expansion Splice Plates

Each AB-COPE-GLAS expansion splice plate allows  $\frac{5}{8}$ " total expansion or contraction under varying temperature conditions. A complete table showing expansion plate placement intervals appears in the AB-COPE-GLAS Accessories section of this catalog.

### Clamping & Securing Cable Tray

AB-COPE-GLAS provides a special hold down clamp

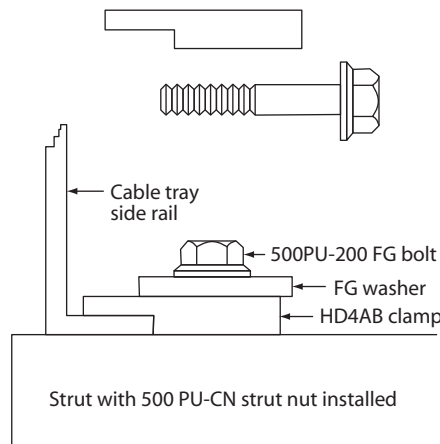

the tray and prevents lateral movement. This clamp is commonly used to prevent lateral tray movement when long runs rest on I-Beams or other horizontal support members.

The HD4AB may also be used to secure tray against a vertical wall or bulkhead. In such applications, the clamp should be located adjacent to and below a rung for extra support. When securing tray to a flat vertical bulkhead, it is also acceptable to drill and bolt directly through the bottom flange of the tray. Holes should be centered in the flange and kept as small as possible ( $\frac{3}{8}$ " diameter max).

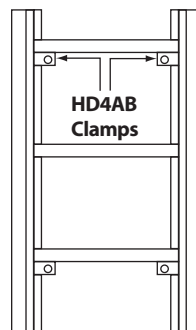

### Wall Brackets

AB-COPE-GLAS fiberglass wall brackets may be used to support cable tray adjacent to a vertical wall. Wall brackets are rated at 750 pounds total weight bearing capacity with a safety factor of 3.0.

Bracket spacing may be determined by dividing 750 lbs. by the tray load (in pounds per foot).

*Example:* With a cable tray loading of 100 lbs./ft., divide 750 lbs. by 100 lbs./ft. = 7.5 feet. One bracket will be required every 7½ feet.

Tray may be secured to the bracket with HD-4 clamps. Note that the brackets are fabricated using Aickinstrut as the main horizontal support member.

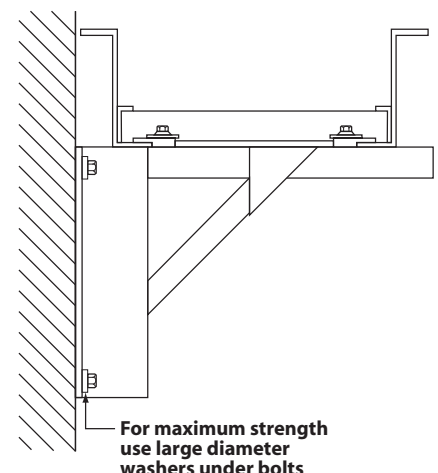

## LADDER CABLE TRAY SYSTEM

### TYPICAL DRAWING

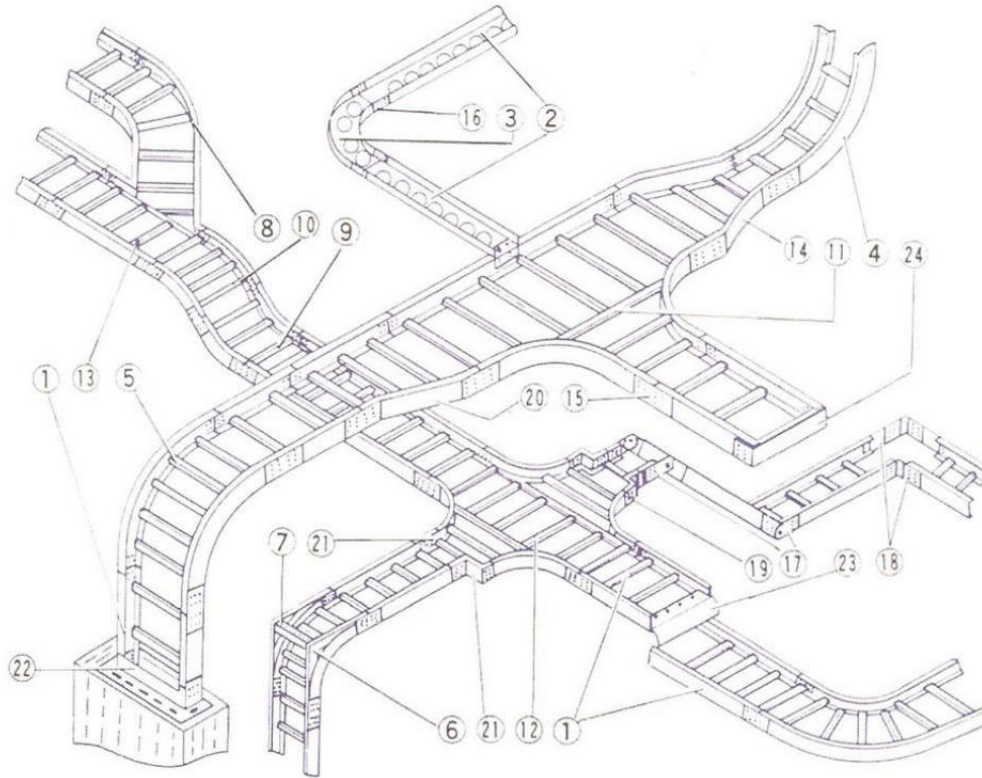

- |   |  |
|---|--|
| 1 CABLE TRAY STRAIGHT SECTION                 | 13 45° HORIZONTAL MOLDED RADIUS WYE BRANCH |
| 2 CABLE CHANNEL-STRAIGHT                      | 14 STRAIGHT REDUCER                        |
| 3 CHANNEL HORIZONTAL FITTING                  | 15 STRAIGHT SECTION CONNECTOR PLATE        |
| 4 90° VERTICAL MOLDED RADIUS ELBOW(INSIDE)    | 16 CHANNEL CONNECTOR                       |
| 5 90° VERTICAL MOLDED RADIUS ELBOW(OUT SIDE)  | 17 ADJUSTABLE RISER CONNECTOR              |
| 6 90° VERTICAL CABLE SUPPORT ELBOW            | 18 HORIZONTAL HINGED SPLICE PLATE          |
| 7 SUPPORT HOOK OR HANGING CABLE               | 19 STRAIGHT REDUCING CONNECTOR             |
| 8 45° HORIZONTAL MOLDED RADIUS ELBOW          | 20 REDUCER(RIGHT HAND)                     |
| 9 45° VERTICAL MOLDED RADIUS ELBOW(IN SIDE)   | 21 OFFSET REDUING CONNECTOR                |
| 10 45° VERTICAL MOLDED RADIUS ELBOW(OUT SIDE) | 22 DROPOUT BOX CONNECTOR                   |
| 11 HORIZONTAL MOLDED RADIUS TEE               | 23 END DROPOUT                             |
| 12 HORIZONTAL MOLDED RADIUS CROSS             | 24 BLIND END PLATE                         |

## LADDER TYPE CABLE TRAY

**AB.Cope CABLE TRAY** are designed, manufactured and tested according to standards set by the National Electrical Manufacturers Association, U.S.A. as per **NEMA FG1-1993**

**AL** - Light Duty Ladder rated at 50kg/m at 3.0m span

**AM** - Medium Duty Ladder rated at 112kg/m at 3.0m span **NEMA Class B and C**

**AH** - Heavy Duty Ladder rated at 112kg/m and 150kg/m at 3.0m, 6.0m span

**NEMA Class B and C**

**AS** - Super Duty Ladder rated at 150kg/m at 6.0m span **NEMA Class C**

**AR** - New Marine Ladder rated at 150kg/m at 2.4m span **NEMA Class C**

1. Identify loading of cables on ladder in kg/m or lb/ft and select support span.
2. The total loading should not exceed values indicated in TABLE 2.

NOTE: WHRT Type Cable Tray Systems has the suitable surface and volume resistivity for installation in hazardous area according to IACS Rules No. 73/4.1 and ABS Steel Vessel Rules 4-8-4A1/9.1 tested in accordance With IEC 60093.

**TABLE 2 : Ladder & Span Selection Chart**

Reference:NEMA FG-1

The working(allowable) load capacity represents the ability of a fiberglass cable tray to support the static weights of cables. It is equivalent to the destruction load capacity, as determined by testing in accordance with paragraph 4.1, with a minimum safety factor 1.5.

| Working (Allowable) load in kg/m and lb/ft |    |                        |       |                         |       |                        |       |                         |       |                        |       |
|--|----|------------------------|-------|-------------------------|-------|------------------------|-------|-------------------------|-------|------------------------|-------|
| Support Span                               |    | Light Duty (WL) Ladder |       | Medium Duty (WM) Ladder |       | Heavy Duty (WH) Ladder |       | Supper Duty (WS) Ladder |       | New Marine (WR) Ladder |       |
| m  | ft | kg/m                   | lb/ft | kg/m                    | lb/ft | kg/m                   | lb/ft | kg/m                    | lb/ft | kg/m                   | lb/ft |
| 6.0  | 20 | -                      | -     | -                       | -     | 50                     | 34    | 150                     | 100   | -                      | -     |
| 5.5  | 18 | -                      | -     | -                       | -     | 71                     | 48    | 183                     | 123   | -                      | -     |
| 4.8  | 16 | -                      | -     | -                       | -     | 98                     | 66    | 232                     | 156   | -                      | -     |
| 4.3  | 14 | -                      | -     | -                       | -     | 112                    | 75    | -                       | -     | -                      | -     |
| 3.6  | 12 | -                      | -     | -                       | -     | 207                    | 139   | -                       | -     | -                      | -     |
| 3.0  | 10 | 50                     | 34    | 112                     | 75    | 298                    | 200   | -                       | -     | -                      | -     |
| 2.4  | 8  | 75                     | 50    | 167                     | 112   | -                      | -     | -                       | -     | 150                    | 100   |

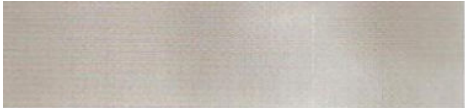

## STRAIGHT SECTIONS

Cable Ladders are fabricated from pultruded components and are normally use in cases where the loading conditions and dimensional width exceed (those of Cable Trays).

Ladders are preferred in power cables support system because of the excellent ventilation they provide.

Cable Ladders are avaiable in standard straight lengths 3 metre or 6 metres and in resin selection of polyester and vinylester resin.

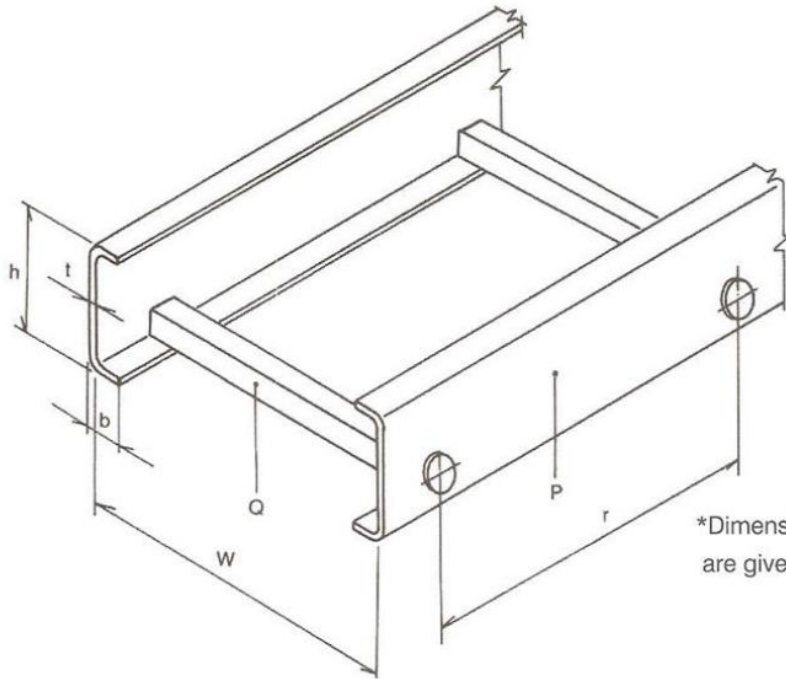

- P : SIDE RAIL
- Q : RUNG-3 TYPES
- W : TRAY WIDTH
- r : RUNG SPACING
- h : SIDE RAIL HEIGHT
- b : FLANGE WIDTH
- t : SIDE RAIL THICKNESS

\*Dimensions and type of Ladder Rung are given in respective charts.

TRAY TYPE    WIDTH    RUNG SPACING CODE #    RESIN SYSTEM    LENGTH

| RUNG TYPES |  |       |
|------------|--|-------|
| A          |  | 15X38 |
| B          |  | 25X25 |
| C          |  | 25X69 |
| D          |  | 25X58 |

EXAMPLE :

AH-300-300-UP-3000 (Polyester)

AL-300-300-VE-3000 (Vinylester)

| AVAILABLE WIDTHS |
|------------------|
| INSIDE DIMENSION |
| 150MM            |
| 230MM            |
| 300MM            |
| 450MM            |
| 600MM            |
| 750MM            |
| 900MM            |

| AVAILABLE RUNG SPACING |                |
|------------------------|----------------|
| Actual mm              | Catalog # Code |
| 150                    | 150            |
| 230                    | 230            |
| 300                    | 300            |
| 470                    | 470            |
| AVAILABLE LENGTHS      |                |
| 3M                     |                |
| 6M                     |                |

## LIGHT DUTY LADDER (AL)

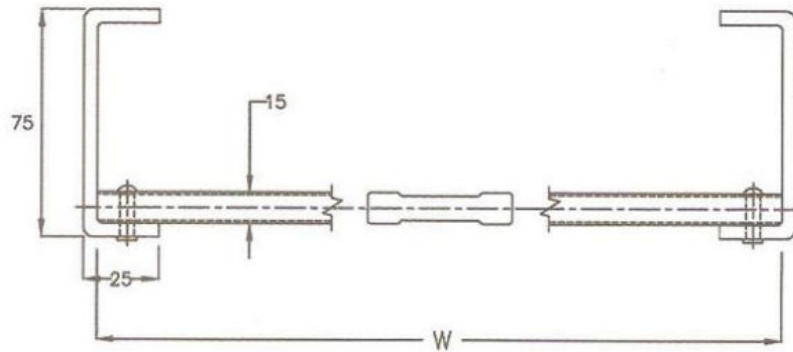

Dimension in mm

| Product Code | Ladder Width ( W ) | Rung Spacing ( R ) | Ladder Rung Type |
|--------------|--------------------|--------------------|------------------|
| AL 150       | 150                | 300                | A                |
| AL 230       | 230                | 300                | A                |
| AL 300       | 300                | 300                | A                |
| AL 450       | 450                | 300                | A                |
| AL 600       | 600                | 300                | A                |

Catalog Numbering

| Height (mm) | Width (mm) | Catalog No.        |                    |
|-------------|------------|--------------------|--------------------|
|             |            | Polyester          | Vinylester         |
| 75          | 150        | AL-150-300-UP-3000 | AL-150-300-VE-3000 |
|             | 230        | AL-230-300-UP-3000 | AL-230-300-VE-3000 |
|             | 300        | AL-300-300-UP-3000 | AL-300-300-VE-3000 |
|             | 450        | AL-450-300-UP-3000 | AL-450-300-VE-3000 |
|             | 600        | AL-600-300-UP-3000 | AL-600-300-VE-3000 |

## MEDIUM DUTY LADDER (AM)

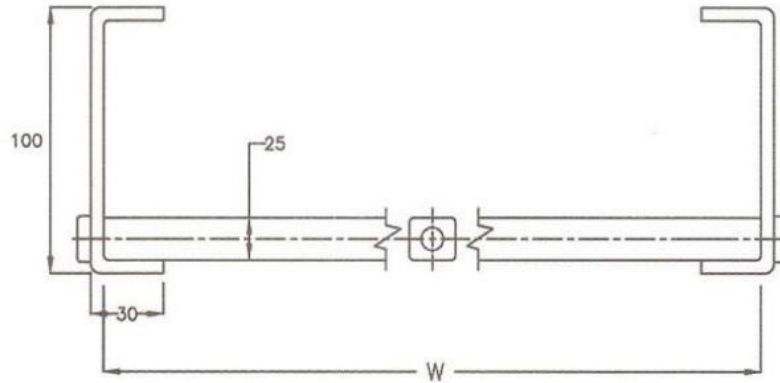

Dimension in mm

| Product Code | Ladder Width (W) | Rung Spacing (R) | Ladder Rung Type |
|--------------|------------------|------------------|------------------|
| AM 150       | 150              | 300              | A · B            |
| AM 300       | 300              | 300              | A · B            |
| AM 450       | 450              | 300              | A · B            |
| AM 600       | 600              | 300              | B                |
| AM 750       | 750              | 300              | B                |
| AM 900       | 900              | 300              | B                |

Catalog Numbering

| Height (mm) | Width (mm) | Catalog No.        |                    |
|-------------|------------|--------------------|--------------------|
|             |            | Polyester          | Vinylester         |
| 100         | 150        | AM-150-300-UP-3000 | AM-150-300-VE-3000 |
|             | 300        | AM-300-300-UP-3000 | AM-300-300-VE-3000 |
|             | 450        | AM-450-300-UP-3000 | AM-450-300-VE-3000 |
|             | 600        | AM-600-300-UP-3000 | AM-600-300-VE-3000 |
|             | 750        | AM-750-300-UP-3000 | AM-750-300-VE-3000 |
|             | 900        | AM-900-300-UP-3000 | AM-900-300-VE-3000 |

## HEAVY DUTY LADDER (AH)

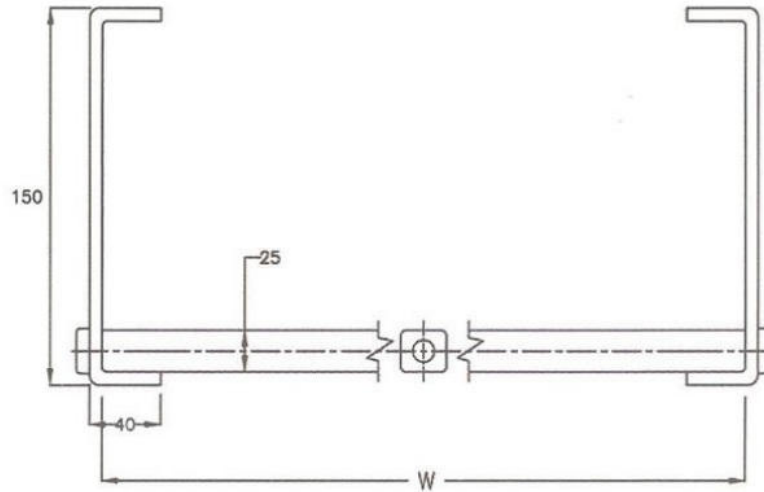

Dimension in mm

| Product Code | Ladder Width (W) | Rung Spacing (R) | Ladder Rung Type |
|--------------|------------------|------------------|------------------|
| AH 150       | 150              | 300              | B · C            |
| AH 300       | 300              | 300              | B · C            |
| AH 450       | 450              | 300              | B · C            |
| AH 600       | 600              | 300              | B · C            |
| AH 750       | 750              | 300              | B · C            |
| AH 900       | 900              | 300              | B · C            |

Catalog Numbering

| Height (mm) | Width (mm) | Catalog No.        |                    |
|-------------|------------|--------------------|--------------------|
|             |            | Polyester          | Vinylester         |
| 150         | 150        | AH-150-300-UP-3000 | AH-150-300-VE-3000 |
|             | 300        | AH-300-300-UP-3000 | AH-300-300-VE-3000 |
|             | 450        | AH-450-300-UP-3000 | AH-450-300-VE-3000 |
|             | 600        | AH-600-300-UP-3000 | AH-600-300-VE-3000 |
|             | 750        | AH-750-300-UP-3000 | AH-750-300-VE-3000 |
|             | 900        | AH-900-300-UP-3000 | AH-900-300-VE-3000 |

## SUPER DUTY LADDER (AS)

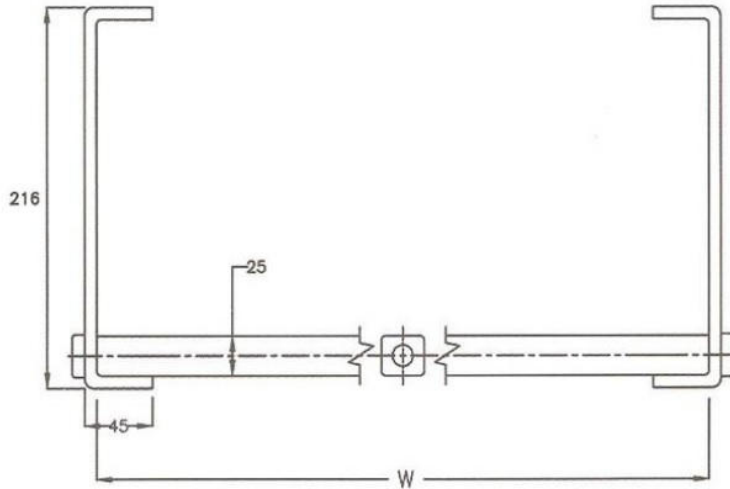

Dimension in mm

| Product Code | Ladder Width (W) | Rung Spacing (R) | Ladder Rung Type |
|--------------|------------------|------------------|------------------|
| AS 150       | 150              | 300              | B · C            |
| AS 300       | 300              | 300              | B · C            |
| AS 450       | 450              | 300              | B · C            |
| AS 600       | 600              | 300              | B · C            |
| AS 750       | 750              | 300              | B · C            |
| AS 900       | 900              | 300              | B · C            |

Catalog Numbering

| Height (mm) | Width (mm) | Catalog No.        |                    |
|-------------|------------|--------------------|--------------------|
|             |            | Polyester          | Vinylester         |
| 216         | 150        | AS-150-300-UP-3000 | AS-150-300-VE-3000 |
|             | 300        | AS-300-300-UP-3000 | AS-300-300-VE-3000 |
|             | 450        | AS-450-300-UP-3000 | AS-450-300-VE-3000 |
|             | 600        | AS-600-300-UP-3000 | AS-600-300-VE-3000 |
|             | 750        | AS-750-300-UP-3000 | AS-750-300-VE-3000 |
|             | 900        | AS-900-300-UP-3000 | AS-900-300-VE-3000 |

## CONCENTRIC CURVED MOLDED FITTINGS

Concentric curved molded fittings are available in polyester and vinylester resin.  
Also available for all tray types.

All fittings carry a Class C rating according to NEMA standards.  
It is recommended to use expansion connector plates and 30mm long assembly fasteners when connecting to other fittings or straight lengths.

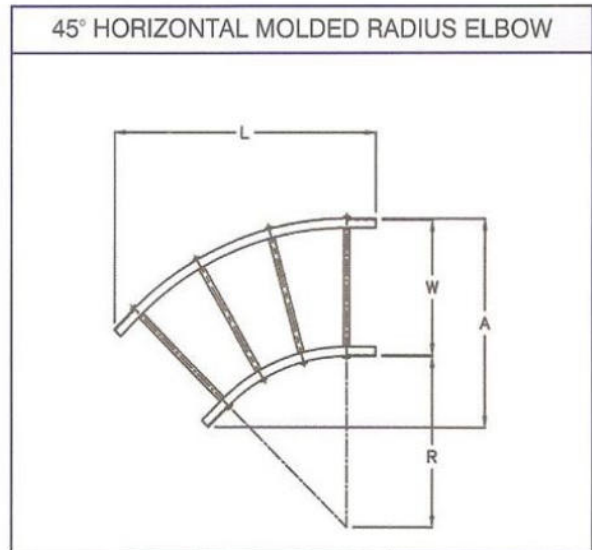
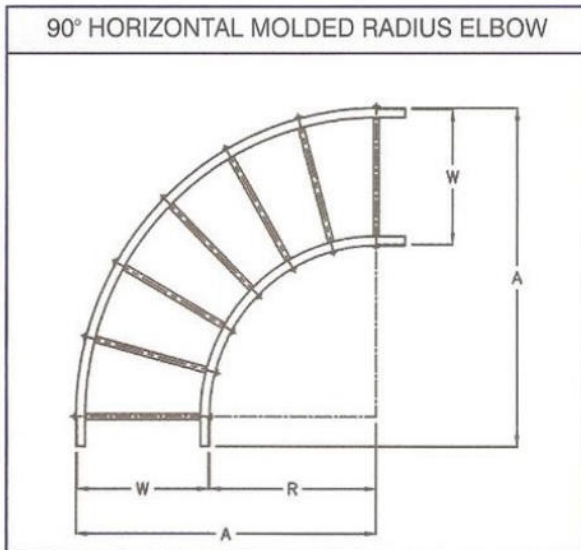

| Width | 300 Radius Dimension |       | 600 Radius Dimension |       | 900 Radius Dimension |       |
|-------|----------------------|-------|----------------------|-------|----------------------|-------|
|       | A                    | L     | A                    | L     | A                    | L     |
| 150   | 612                  | 865   | 912                  | 1,290 | 1,212                | 1,714 |
| 230   | 692                  | 979   | 992                  | 1,403 | 1,292                | 1,827 |
| 300   | 762                  | 1,078 | 1,062                | 1,502 | 1,362                | 1,926 |
| 450   | 912                  | 1,290 | 1,212                | 1,714 | 1,512                | 2,138 |
| 600   | 1,062                | 1,502 | 1,362                | 1,926 | 1,662                | 2,350 |
| 750   | 1,212                | 1,714 | 1,512                | 2,138 | 1,812                | 2,563 |
| 900   | 1,362                | 1,926 | 1,662                | 2,350 | 1,962                | 2,775 |

NOTE: Typical Catalog No.  
==> AHE-W-90-RS-R

| Width | 300 Radius Dimension |       | 600 Radius Dimension |       | 900 Radius Dimension |       |
|-------|----------------------|-------|----------------------|-------|----------------------|-------|
|       | A                    | L     | A                    | L     | A                    | L     |
| 150   | 356                  | 583   | 444                  | 795   | 532                  | 1,007 |
| 230   | 436                  | 639   | 524                  | 851   | 612                  | 1,064 |
| 300   | 506                  | 689   | 594                  | 901   | 682                  | 1,113 |
| 450   | 656                  | 795   | 744                  | 1,007 | 832                  | 1,219 |
| 600   | 806                  | 901   | 894                  | 1,113 | 982                  | 1,325 |
| 750   | 956                  | 1,007 | 1,044                | 1,219 | 1,132                | 1,431 |
| 900   | 1,106                | 1,113 | 1,194                | 1,325 | 1,282                | 1,537 |

NOTE: Typical Catalog No.  
==> AHE-W-45-RS-R

NOTE: It is available 60° and 30° Horizontal Molded Radius Elbow.

90° VERTICAL INSIDE MOLDED RADIUS ELBOW

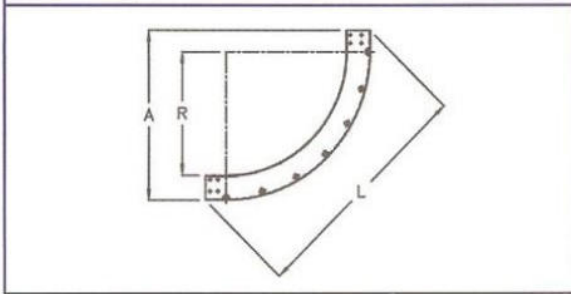

| Width | 300 Radius Dimension |     | 600 Radius Dimension |       | 900 Radius Dimension |       |
|-------|----------------------|-----|----------------------|-------|----------------------|-------|
|       | A                    | L   | A                    | L     | A                    | L     |
| 150   | 600                  | 849 | 900                  | 1,273 | 1,200                | 1,697 |
| 230   | 600                  | 849 | 900                  | 1,273 | 1,200                | 1,697 |
| 300   | 600                  | 849 | 900                  | 1,273 | 1,200                | 1,697 |
| 450   | 600                  | 849 | 900                  | 1,273 | 1,200                | 1,697 |
| 600   | 600                  | 849 | 900                  | 1,273 | 1,200                | 1,697 |
| 750   | 600                  | 849 | 900                  | 1,273 | 1,200                | 1,697 |
| 900   | 600                  | 849 | 900                  | 1,273 | 1,200                | 1,697 |

NOTE: Typical Catalog No.  
==> AVEI-W-90-RS-R

45° VERTICAL INSIDE MOLDED RADIUS ELBOW

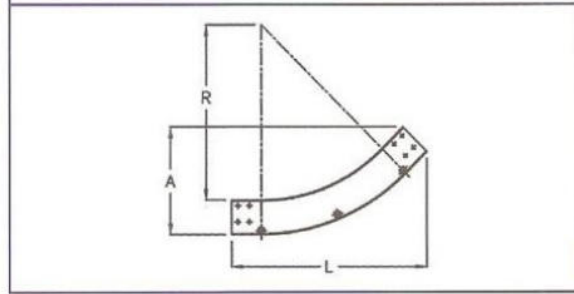

| Width | 300 Radius Dimension |     | 600 Radius Dimension |     | 900 Radius Dimension |     |
|-------|----------------------|-----|----------------------|-----|----------------------|-----|
|       | A                    | L   | A                    | L   | A                    | L   |
| 150   | 344                  | 574 | 432                  | 786 | 520                  | 998 |
| 230   | 344                  | 574 | 432                  | 786 | 520                  | 998 |
| 300   | 344                  | 574 | 432                  | 786 | 520                  | 998 |
| 450   | 344                  | 574 | 432                  | 786 | 520                  | 998 |
| 600   | 344                  | 574 | 432                  | 786 | 520                  | 998 |
| 750   | 344                  | 574 | 432                  | 786 | 520                  | 998 |
| 900   | 344                  | 574 | 432                  | 786 | 520                  | 998 |

NOTE: Typical Catalog No.  
==> AVEI-W-45-RS-R

90° VERTICAL OUTSIDE MOLDED RADIUS ELBOW

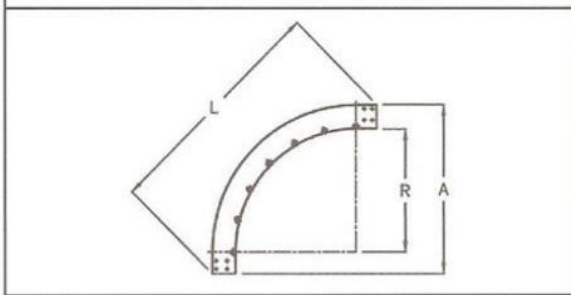

| Width | 300 Radius Dimension |     | 600 Radius Dimension |       | 900 Radius Dimension |       |
|-------|----------------------|-----|----------------------|-------|----------------------|-------|
|       | A                    | L   | A                    | L     | A                    | L     |
| 150   | 600                  | 849 | 900                  | 1,273 | 1,200                | 1,697 |
| 230   | 600                  | 849 | 900                  | 1,273 | 1,200                | 1,697 |
| 300   | 600                  | 849 | 900                  | 1,273 | 1,200                | 1,697 |
| 450   | 600                  | 849 | 900                  | 1,273 | 1,200                | 1,697 |
| 600   | 600                  | 849 | 900                  | 1,273 | 1,200                | 1,697 |
| 750   | 600                  | 849 | 900                  | 1,273 | 1,200                | 1,697 |
| 900   | 600                  | 849 | 900                  | 1,273 | 1,200                | 1,697 |

NOTE: Typical Catalog No.  
==> AVEO-W-90-RS-R

45° VERTICAL OUTSIDE MOLDED RADIUS ELBOW

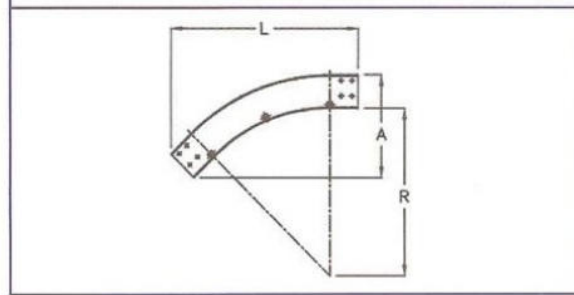

| Width | 300 Radius Dimension |     | 600 Radius Dimension |     | 900 Radius Dimension |     |
|-------|----------------------|-----|----------------------|-----|----------------------|-----|
|       | A                    | L   | A                    | L   | A                    | L   |
| 150   | 344                  | 574 | 432                  | 786 | 520                  | 998 |
| 230   | 344                  | 574 | 432                  | 786 | 520                  | 998 |
| 300   | 344                  | 574 | 432                  | 786 | 520                  | 998 |
| 450   | 344                  | 574 | 432                  | 786 | 520                  | 998 |
| 600   | 344                  | 574 | 432                  | 786 | 520                  | 998 |
| 750   | 344                  | 574 | 432                  | 786 | 520                  | 998 |
| 900   | 344                  | 574 | 432                  | 786 | 520                  | 998 |

NOTE: Typical Catalog No.  
==> AVEO-W-45-RS-R

NOTE: It is available 60° and 30° Horizontal Inside/Outside Molded Radius Elbow.

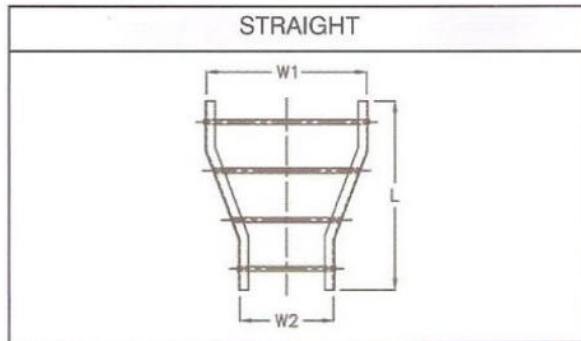

| W1            | W1    |       |       |       |       |       |
|---------------|-------|-------|-------|-------|-------|-------|
|               | 900   | 750   | 600   | 450   | 300   | 230   |
| 150           | 1,050 | 1,050 | 1,050 | 1,050 | 1,050 | 1,050 |
| 230           | 1,050 | 1,050 | 1,050 | 1,050 | 1,050 | -     |
| 300           | 1,050 | 1,050 | 1,050 | 1,050 | -     | -     |
| 450           | 1,050 | 1,050 | 1,050 | -     | -     | -     |
| 600           | 1,050 | 1,050 | -     | -     | -     | -     |
| 750           | 1,050 | -     | -     | -     | -     | -     |
| DIMENSION "L" |       |       |       |       |       |       |

NOTE: Typical Catalog No.  
==> ARS-W1-W2-RS

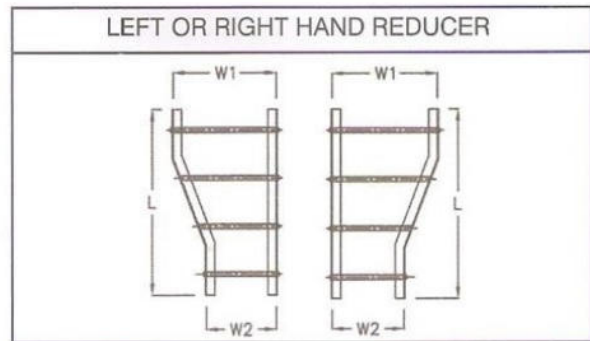

| W2            | W1    |       |       |       |       |       |
|---------------|-------|-------|-------|-------|-------|-------|
|               | 900   | 750   | 600   | 450   | 300   | 230   |
| 150           | 1,050 | 1,050 | 1,050 | 1,050 | 1,050 | 1,050 |
| 230           | 1,050 | 1,050 | 1,050 | 1,050 | 1,050 | -     |
| 300           | 1,050 | 1,050 | 1,050 | 1,050 | -     | -     |
| 450           | 1,050 | 1,050 | 1,050 | -     | -     | -     |
| 600           | 1,050 | 1,050 | -     | -     | -     | -     |
| 750           | 1,050 | -     | -     | -     | -     | -     |
| DIMENSION "L" |       |       |       |       |       |       |

NOTE: Typical Catalog No.  
==> ARL/R-W1-W2-RS

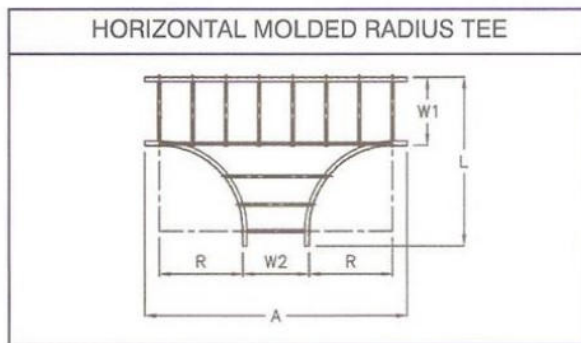

| Width | 300 Radius Dimension |        | 600 Radius Dimension |       | 900 Radius Dimension |       |
|-------|----------------------|--------|----------------------|-------|----------------------|-------|
|       | A                    | L      | A                    | L     | A                    | L     |
| 150   | 1,062                | 612    | 1,662                | 912   | 2,262                | 1,212 |
| 230   | 1,062                | 692    | 1,742                | 992   | 2,342                | 1,292 |
| 300   | 1,062                | 762    | 1,812                | 1,062 | 2,412                | 1,362 |
| 450   | 1,062                | 912    | 1,962                | 1,212 | 2,562                | 1,512 |
| 600   | 1,062                | 1,062  | 2,112                | 1,362 | 2,712                | 1,662 |
| 750   | 1,062                | 1,212  | 2,262                | 1,512 | 2,862                | 1,812 |
| 900   | 1,062                | 1,1362 | 2,412                | 1,662 | 3,012                | 1,962 |

NOTE: Typical Catalog No.  
==> AHT-W<sub>1</sub>-W<sub>2</sub>-RS-R

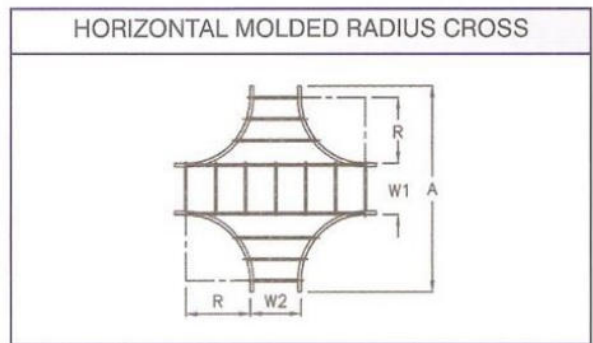

| Width | 300 Radius Dimension | 600 Radius Dimension | 900 Radius Dimension |
|-------|----------------------|----------------------|----------------------|
|       | A                    | A                    | A                    |
| 150   | 1,062                | 1,662                | 2,262                |
| 230   | 1,142                | 1,742                | 2,342                |
| 300   | 1,212                | 1,812                | 2,412                |
| 450   | 1,362                | 1,962                | 2,562                |
| 600   | 1,512                | 2,112                | 2,712                |
| 750   | 1,662                | 2,262                | 2,862                |
| 900   | 1,812                | 2,412                | 3,012                |

NOTE: Typical Catalog No.  
==> AHC-W<sub>1</sub>-W<sub>2</sub>-RS-R

## MITERED FITTINGS

Pre-assembled "mitered" fittings are available for all tray types with the exception of those fittings (or 150mm deep tray which appear in the **Concentric Curved Molded Fitting Section**.

All fittings are assembled using Stainless Steel or GRP fasteners unless otherwise specified.

It is recommended that expansion connector plates be used when connecting to molded fittings or straight sections.

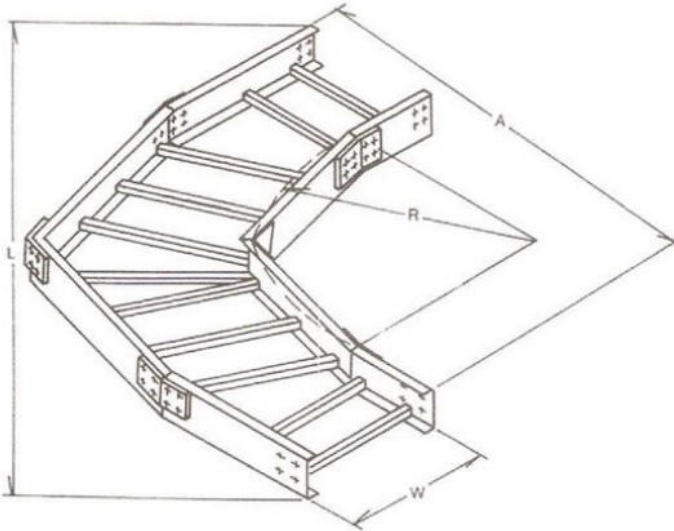

### 90° HORIZONTAL RADIUS ELBOW

TYPICAL CATALOG NO : AHEM-W-45-RS-R

| Width | 300 Radius Dimension |      | 600 Radius Dimension |      | 900 Radius Dimension |      |
|-------|----------------------|------|----------------------|------|----------------------|------|
|       | A                    | L    | A                    | L    | A                    | L    |
| 150   | 580                  | 820  | 880                  | 1245 | 1180                 | 1668 |
| 230   | 660                  | 933  | 960                  | 1358 | 1260                 | 1782 |
| 300   | 730                  | 1032 | 1030                 | 1456 | 1330                 | 1880 |
| 450   | 880                  | 1245 | 1180                 | 1668 | 1480                 | 2093 |
| 600   | 1030                 | 1457 | 1330                 | 1880 | 1630                 | 2305 |
| 750   | 1180                 | 1668 | 1480                 | 2093 | 1780                 | 2517 |
| 900   | 1330                 | 1880 | 1630                 | 2305 | 1930                 | 2729 |

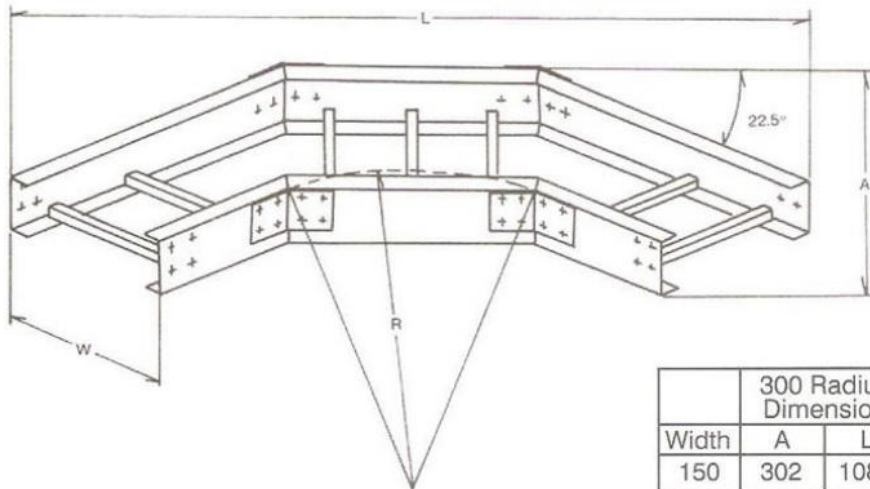

### 45° HORIZONTAL RADIUS ELBOW

TYPICAL CATALOG NO : AHEM-W-45-RS-R

| Width | 300 Radius Dimension |      | 600 Radius Dimension |      | 900 Radius Dimension |      |
|-------|----------------------|------|----------------------|------|----------------------|------|
|       | A                    | L    | A                    | L    | A                    | L    |
| 150   | 302                  | 1085 | 302                  | 1315 | 302                  | 1543 |
| 230   | 382                  | 1146 | 382                  | 1376 | 382                  | 1658 |
| 300   | 452                  | 1200 | 452                  | 1430 | 452                  | 1728 |
| 450   | 602                  | 1314 | 602                  | 1544 | 602                  | 1772 |
| 600   | 752                  | 1429 | 752                  | 1659 | 752                  | 1887 |
| 750   | 902                  | 1544 | 902                  | 1774 | 902                  | 2002 |
| 900   | 1052                 | 1659 | 1052                 | 1889 | 1052                 | 2117 |

## 45° DIRECT INSIDE VERTICAL ELBOW

TYPICAL CATALOG NO:  
AVEMDI-W-45-RS

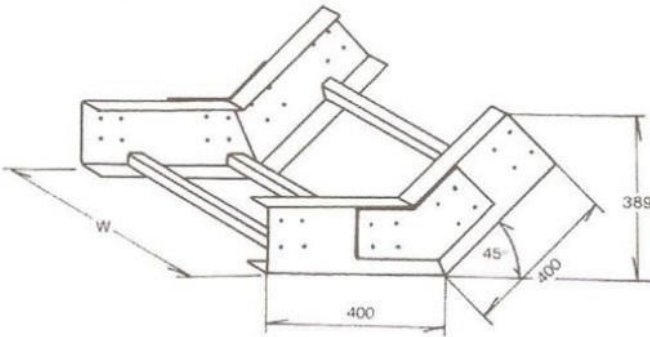

## 45° DIRECT OUTSIDE VERTICAL ELBOW

TYPICAL CATALOG NO:  
AVEMDO-W-45-RS

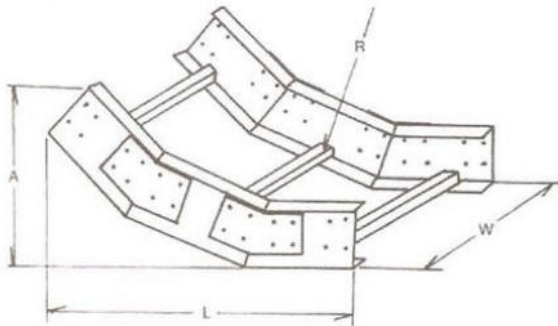
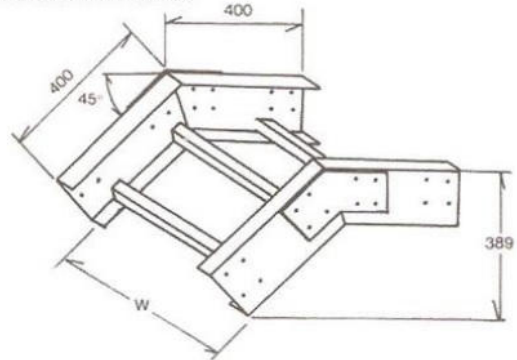

## 45° INSIDE VERTICAL RADIUS ELBOW

TYPICAL CATALOG NO:  
AVEMI-W-45-RS-R

| RADIUS | DIMENSION |     |
|--------|-----------|-----|
|        | A         | L   |
| 300    | 339       | 541 |
| 600    | 417       | 751 |
| 900    | 506       | 964 |

## 45° OUTSIDE VERTICAL RADIUS ELBOW

TYPICAL CATALOG NO:  
AVEMO-W-45-RS-R

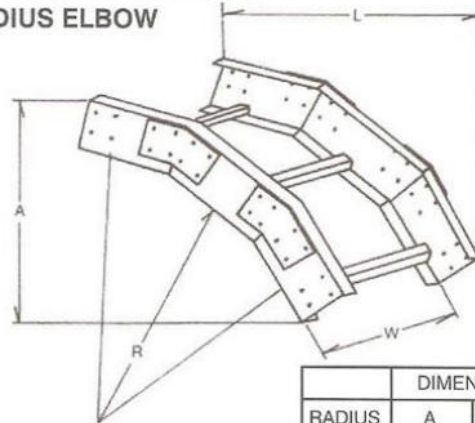

| RADIUS | DIMENSION |     |
|--------|-----------|-----|
|        | A         | L   |
| 300    | 339       | 541 |
| 600    | 417       | 751 |
| 900    | 500       | 964 |

## 90° INSIDE VERTICAL RADIUS ELBOW

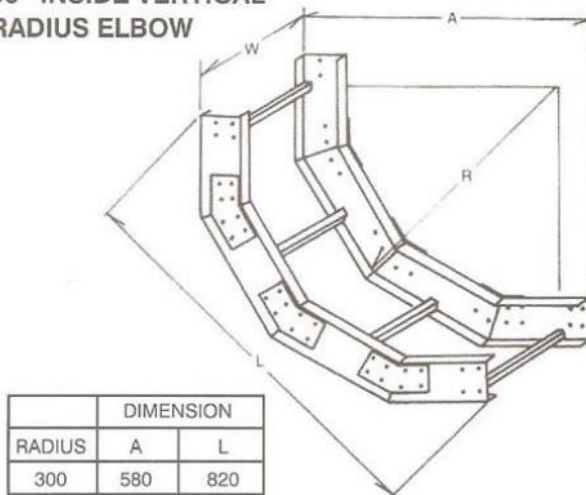

| RADIUS | DIMENSION |      |
|--------|-----------|------|
|        | A         | L    |
| 300    | 580       | 820  |
| 600    | 880       | 1245 |
| 900    | 1180      | 1669 |

TYPICAL CATALOG NO:  
AVEMI-W-90-RS-R

## 90° OUTSIDE VERTICAL RADIUS ELBOW

TYPICAL CATALOG NO:  
AVEMO-W-90-RS-R

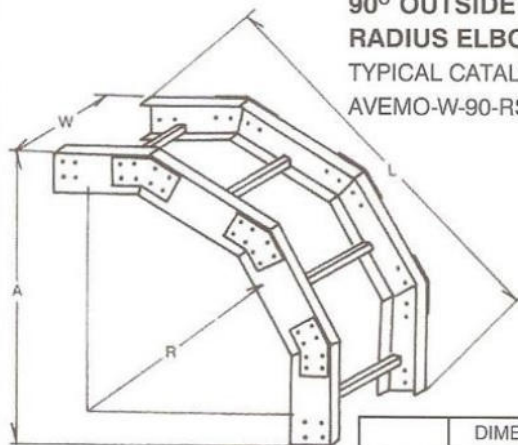

| RADIUS | DIMENSION |      |
|--------|-----------|------|
|        | A         | L    |
| 300    | 580       | 820  |
| 600    | 880       | 1245 |
| 900    | 1180      | 1669 |

## STRAIGHT REDUCER

|               |     | W1    |       |       |       |       |       |
|---------------|-----|-------|-------|-------|-------|-------|-------|
|               |     | 900   | 750   | 600   | 450   | 300   | 230   |
| W2            | 150 | 1,050 | 1,050 | 1,050 | 1,050 | 1,050 | 1,050 |
|               | 230 | 1,050 | 1,050 | 1,050 | 1,050 | 1,050 | -     |
|               | 300 | 1,050 | 1,050 | 1,050 | 1,050 | -     | -     |
|               | 450 | 1,050 | 1,050 | 1,050 | -     | -     | -     |
|               | 600 | 1,050 | 1,050 | -     | -     | -     | -     |
|               | 750 | 1,050 | -     | -     | -     | -     | -     |
| DIMENSION "L" |     |       |       |       |       |       |       |

TYPICAL CATALOG NO: ARMS - W<sub>1</sub> - W<sub>2</sub> - RS

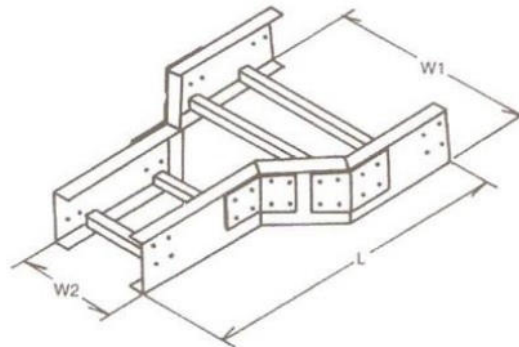

TYPICAL CATALOG NO:

Right Hand :

ARMR-W<sub>1</sub> - W<sub>2</sub> - RS

Left Hand :

ARML-W<sub>1</sub> - W<sub>2</sub> - RS

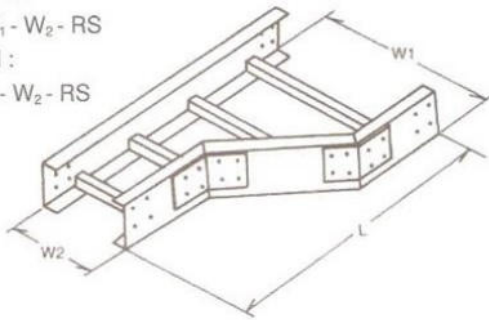

## RIGHT OR LEFT HAND REDUCER

|               |     | W1    |       |       |       |       |       |
|---------------|-----|-------|-------|-------|-------|-------|-------|
|               |     | 900   | 750   | 600   | 450   | 300   | 230   |
| W2            | 150 | 1,050 | 1,050 | 1,050 | 1,050 | 1,050 | 1,050 |
|               | 230 | 1,050 | 1,050 | 1,050 | 1,050 | 1,050 | -     |
|               | 300 | 1,050 | 1,050 | 1,050 | 1,050 | -     | -     |
|               | 450 | 1,050 | 1,050 | 1,050 | -     | -     | -     |
|               | 600 | 1,050 | 1,050 | -     | -     | -     | -     |
|               | 750 | 1,050 | -     | -     | -     | -     | -     |
| DIMENSION "L" |     |       |       |       |       |       |       |

## HORIZONTAL RADIUS TEE

| Width | 300 Radius Dimension |      | 600 Radius Dimension |      | 900 Radius Dimension |      |
|-------|----------------------|------|----------------------|------|----------------------|------|
|       | A                    | L    | A                    | L    | A                    | L    |
| 150   | 700                  | 1250 | 1000                 | 1850 | 1300                 | 2450 |
| 230   | 780                  | 1330 | 1080                 | 1930 | 1380                 | 2530 |
| 300   | 850                  | 1400 | 1150                 | 2000 | 1450                 | 2600 |
| 450   | 1000                 | 1550 | 1300                 | 2150 | 1600                 | 2750 |
| 600   | 1150                 | 1700 | 1450                 | 2300 | 1750                 | 2900 |
| 750   | 1300                 | 1850 | 1600                 | 2450 | 1900                 | 3050 |
| 900   | 1450                 | 2000 | 1750                 | 2600 | 2050                 | 3200 |

TYPICAL CATALOG NO:  
AHTM - W<sub>1</sub> - W<sub>2</sub> - RS - R

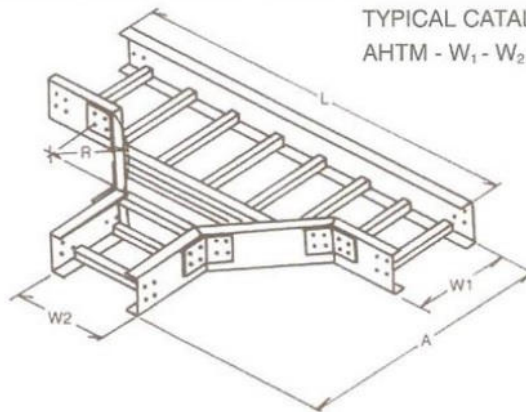

## HORIZONTAL RADIUS CROSS

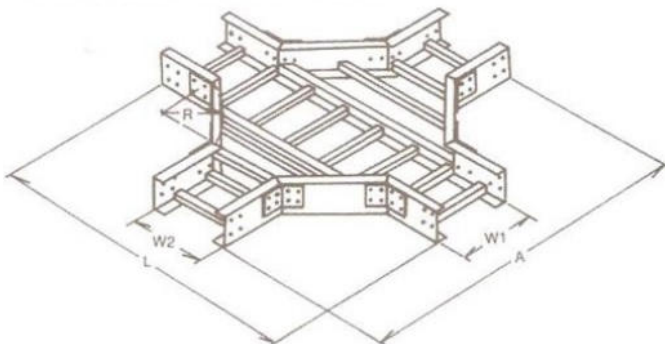

TYPICAL CATALOG NO: AHCM - W<sub>1</sub> - W<sub>2</sub> - RS - R

| Width | 300 Radius Dimension |      | 600 Radius Dimension |      | 900 Radius Dimension |      |
|-------|----------------------|------|----------------------|------|----------------------|------|
|       | A                    | L    | A                    | L    | A                    | L    |
| 150   | 1250                 | 1250 | 1850                 | 1850 | 2450                 | 2450 |
| 230   | 1330                 | 1330 | 1930                 | 1930 | 2530                 | 2530 |
| 300   | 1400                 | 1400 | 2000                 | 2000 | 2600                 | 2600 |
| 450   | 1550                 | 1550 | 2150                 | 2150 | 2750                 | 2750 |
| 600   | 1700                 | 1700 | 2300                 | 2300 | 2900                 | 2900 |
| 750   | 1850                 | 1850 | 2450                 | 2450 | 3050                 | 3050 |
| 900   | 2000                 | 2000 | 2600                 | 2600 | 3200                 | 3200 |

## STRAIGHT REDUCER

|    |               | W1    |       |       |       |       |       |
|----|---------------|-------|-------|-------|-------|-------|-------|
|    |               | 900   | 750   | 600   | 450   | 300   | 230   |
| W2 | 150           | 1,050 | 1,050 | 1,050 | 1,050 | 1,050 | 1,050 |
|    | 230           | 1,050 | 1,050 | 1,050 | 1,050 | 1,050 | -     |
|    | 300           | 1,050 | 1,050 | 1,050 | 1,050 | -     | -     |
|    | 450           | 1,050 | 1,050 | 1,050 | -     | -     | -     |
|    | 600           | 1,050 | 1,050 | -     | -     | -     | -     |
|    | 750           | 1,050 | -     | -     | -     | -     | -     |
|    | DIMENSION "L" |       |       |       |       |       |       |

TYPICAL CATALOG NO: ARMS - W<sub>1</sub> - W<sub>2</sub> - RS

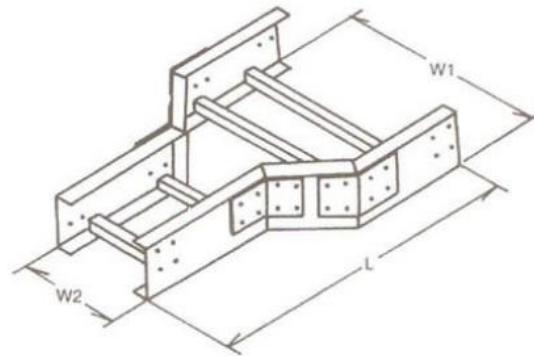

TYPICAL CATALOG NO:

Right Hand :

ARMR-W<sub>1</sub> - W<sub>2</sub> - RS

Left Hand :

ARML-W<sub>1</sub> - W<sub>2</sub> - RS

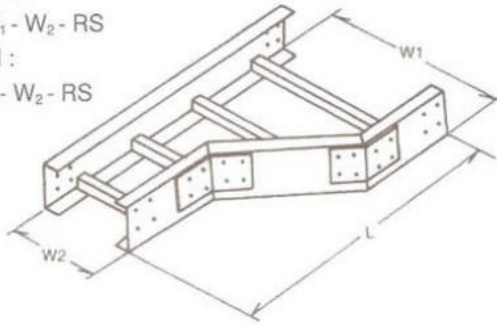

## RIGHT OR LEFT HAND REDUCER

|    |               | W1    |       |       |       |       |       |
|----|---------------|-------|-------|-------|-------|-------|-------|
|    |               | 900   | 750   | 600   | 450   | 300   | 230   |
| W2 | 150           | 1,050 | 1,050 | 1,050 | 1,050 | 1,050 | 1,050 |
|    | 230           | 1,050 | 1,050 | 1,050 | 1,050 | 1,050 | -     |
|    | 300           | 1,050 | 1,050 | 1,050 | 1,050 | -     | -     |
|    | 450           | 1,050 | 1,050 | 1,050 | -     | -     | -     |
|    | 600           | 1,050 | 1,050 | -     | -     | -     | -     |
|    | 750           | 1,050 | -     | -     | -     | -     | -     |
|    | DIMENSION "L" |       |       |       |       |       |       |

## HORIZONTAL RADIUS TEE

| Width | 300 Radius Dimension |      | 600 Radius Dimension |      | 900 Radius Dimension |      |
|-------|----------------------|------|----------------------|------|----------------------|------|
|       | A                    | L    | A                    | L    | A                    | L    |
| 150   | 700                  | 1250 | 1000                 | 1850 | 1300                 | 2450 |
| 230   | 780                  | 1330 | 1080                 | 1930 | 1380                 | 2530 |
| 300   | 850                  | 1400 | 1150                 | 2000 | 1450                 | 2600 |
| 450   | 1000                 | 1550 | 1300                 | 2150 | 1600                 | 2750 |
| 600   | 1150                 | 1700 | 1450                 | 2300 | 1750                 | 2900 |
| 750   | 1300                 | 1850 | 1600                 | 2450 | 1900                 | 3050 |
| 900   | 1450                 | 2000 | 1750                 | 2600 | 2050                 | 3200 |

TYPICAL CATALOG NO:

AHTM - W<sub>1</sub> - W<sub>2</sub> - RS - R

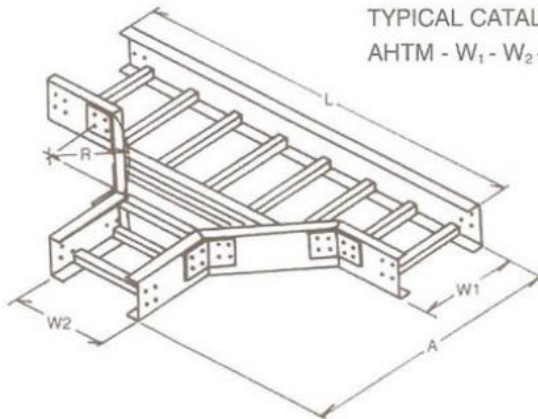

## HORIZONTAL RADIUS CROSS

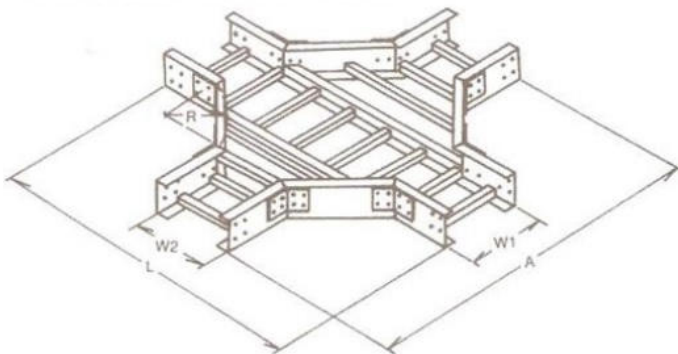

TYPICAL CATALOG NO: AHCM - W<sub>1</sub> - W<sub>2</sub> - RS - R

| Width | 300 Radius Dimension |      | 600 Radius Dimension |      | 900 Radius Dimension |      |
|-------|----------------------|------|----------------------|------|----------------------|------|
|       | A                    | L    | A                    | L    | A                    | L    |
| 150   | 1250                 | 1250 | 1850                 | 1850 | 2450                 | 2450 |
| 230   | 1330                 | 1330 | 1930                 | 1930 | 2530                 | 2530 |
| 300   | 1400                 | 1400 | 2000                 | 2000 | 2600                 | 2600 |
| 450   | 1550                 | 1550 | 2150                 | 2150 | 2750                 | 2750 |
| 600   | 1700                 | 1700 | 2300                 | 2300 | 2900                 | 2900 |
| 750   | 1850                 | 1850 | 2450                 | 2450 | 3050                 | 3050 |
| 900   | 2000                 | 2000 | 2600                 | 2600 | 3200                 | 3200 |

## Cover clamps

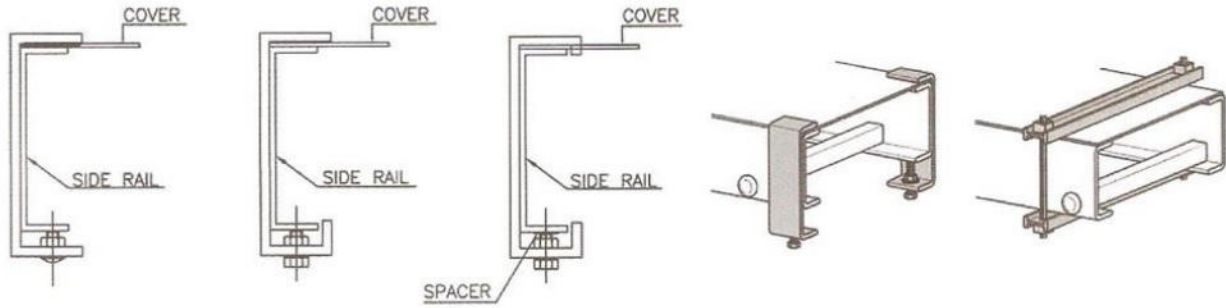

Catalog No.  
: ABUC - A

Catalog No.  
: ABUC - B

Catalog No.  
: ABUC - C

Catalog No.  
: ABIC - (Width)

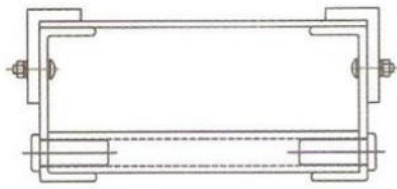

Catalog No.: ABLC

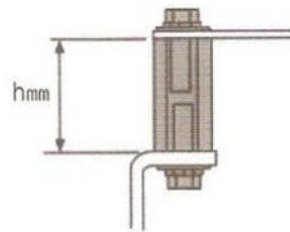

Catalog No.: ABSC

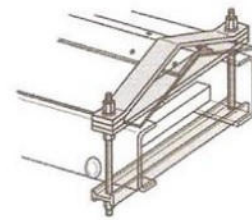

Catalog No.: ABSC - (Width)

## Clampless Type

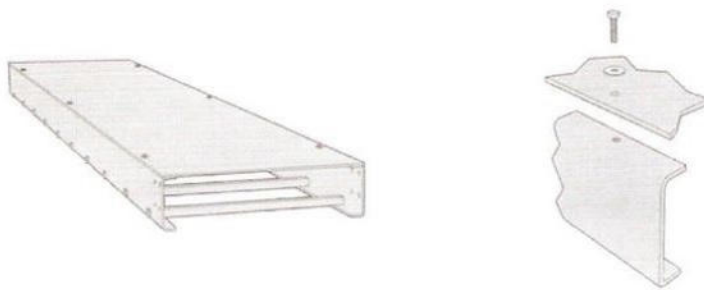

TYPICAL CATALOG ACBC

Available Tray Width (mm):  
150/300/450/600/750/900

### Installation Methods for Clampless Type

Eliminates the need for Cover Clamp for quicker and easier field installation.

Recommended to be purchased with a cable tray straight section matching the clampless flat cover section.

Ø6mm bolt sets are provided.

All fitting are available on this type of cover system.

## COVERS / COVER CLAMPS

### Flat Type

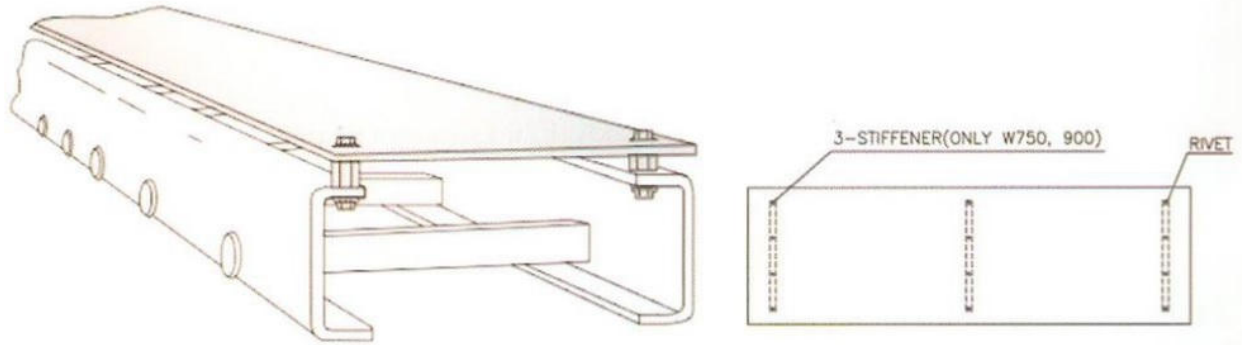

Catalog No.: ACF - (Width) - RS - L

#### Installation Methods for Flat Type

Thermoplastic Drive Rivets are the most economical method, but do require field drilling.

It is recommended rivets be installed on 600mm centers along both side rails.

Cover Clamp and Stand Offs allow Cover to removed for easy access to cables.

It is recommended to use seven pair at 500mm on center per 3M length of cover.

Add ventilation height hmm for flat cover.

### Peaked Type

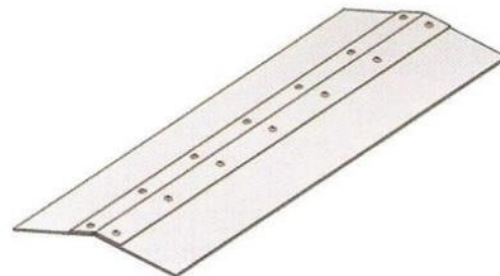

Catalog No.: ACP - (Width) - RS - L

#### Installation Methods for Peaked Type

Use 3 pair of Peaked Cover Clamp for each 3M length of tray.

Peaked cover is not available for fitting.

Contact factory for information on 22.5°, 30° and 45° peaked covers.

Add ventilation height hmn for Peaked Cover,

## CONCENTRIC / SPLICE PLATES AND FASTENERS

**AB.Cope** GRP(Glassfiber Reinforced Plastics) and SUS 316 connector plates designed so as to have the same load carrying capacity as the straight sections.

It is important to refer to NEMA Standards regarding tray installation as it pertains to support and connection locations for straight sections and fittings.

Connector plates and fasteners are sold separately and are not provided standardly with straight sections or preassembled fittings.

All plates have Ø12mm pre-drilled bolt holes.

### CONNECTOR PLATES

| DESCRIPTION     |                     | CONNECTOR/SPLICE PLATE CATALOG NUMBERS |                       |                     |               |                 |                     |
|-----------------|---------------------|--|-----------------------|---------------------|---------------|-----------------|---------------------|
| Siderail Height | Bolt Sets Per Plate | Expansion                              | Adjustable Horizontal | Adjustable Vertical | Special       | Straight        | Clamp Type Vertical |
| 75              | 4                   | AEC- 75-UP-180                         | AHC- 75-UP-A          | AVC- 75-UP-A        | ASC- 75-UP-S  | ASC- 75-UP-180  | AVC- 75-UP-C        |
| 100             | 4                   | AEC- 100-UP-180                        | AHC- 100-UP-A         | AVC- 100-UP-A       | ASC- 100-UP-S | ASC- 100-UP-180 | AVC- 100-UP-C       |
| 150             | 8                   | AEC- 150-UP-180                        | AHC- 150-UP-A         | AVC- 150-UP-A       | ASC- 150-UP-S | ASC- 150-UP-180 | AVC- 150-UP-C       |
| 216             | 8                   | AEC- 216-UP-180                        | AHC- 216-UP-A         | AVC- 216-UP-A       | ASC- 216-UP-S | ASC- 216-UP-180 | AVC- 216-UP-C       |

| DESCRIPTION     |                     | CONNECTOR/SPLICE PLATE CATALOG NUMBERS |                |                |               |                |                |
|-----------------|---------------------|--|----------------|----------------|---------------|----------------|----------------|
| Siderail Height | Bolt Sets Per Plate | 90° Horizontal                         | 45° Horizontal | 30° Horizontal | 90° Vertical  | 45° Vertical   | 30° Vertical   |
| 75              | 4                   | AHC- 75-UP-90                          | AHC- 75-UP-45  | AHC- 75-UP-30  | ASC- 75-UP-S  | AVC- 75-UP-45  | AVC- 75-UP-30  |
| 100             | 4                   | AHC- 100-UP-90                         | AHC- 100-UP-45 | AHC- 100-UP-30 | ASC- 100-UP-S | AVC- 100-UP-45 | AVC- 100-UP-30 |
| 150             | 8                   | AHC- 150-UP-90                         | AHC- 150-UP-45 | AHC- 150-UP-30 | ASC- 150-UP-S | AVC- 150-UP-45 | AVC- 150-UP-30 |
| 216             | 8                   | AHC- 216-UP-90                         | AHC- 216-UP-45 | AHC- 216-UP-30 | ASC- 216-UP-S | AVC- 216-UP-45 | AVC- 216-UP-30 |

### ASSEMBLY FASTENERS

| DESCRIPTION                 | SIZE      | FOR USE WITH TRAY TYPES | CATALOG NO.    |
|-----------------------------|-----------|-------------------------|----------------|
| TYPE 304<br>STAINLESS STEEL | M10 X 30L | AL, AM, AH, AS          | AAF-SS304-1030 |
|                             | M10 X 45L |                         | AAF-SS304-1045 |
| TYPE 316<br>STAINLESS STEEL | M10 X 30L | AL, AM, AH, AS          | AAF-SS316-1030 |
|                             | M10 X 45L |                         | AAF-SS316-1045 |

Sets Include: \* Bolt/Nut, 2 Flat Washers, 1 Lock Washer

Notes: - It is recommended that expansion connector plates and 30mm long assembly fasteners be used when connecting molded fittings to other fittings or straight lengths.

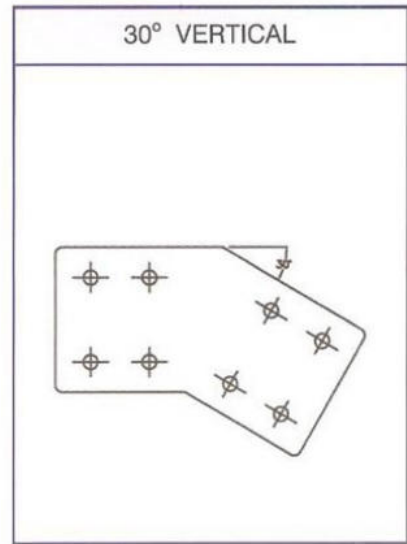
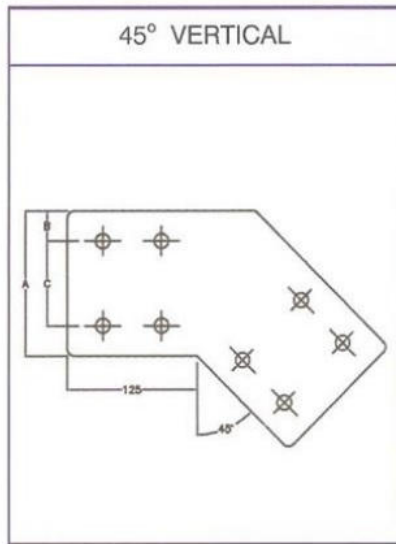
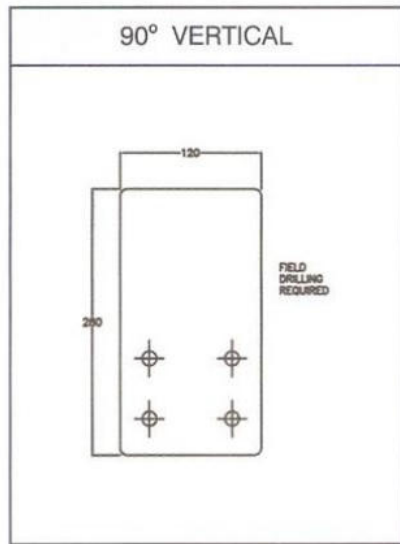
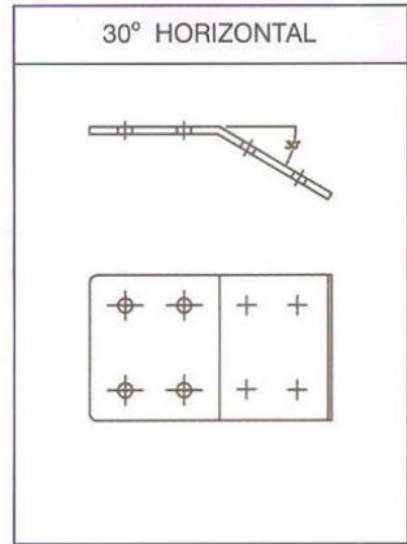
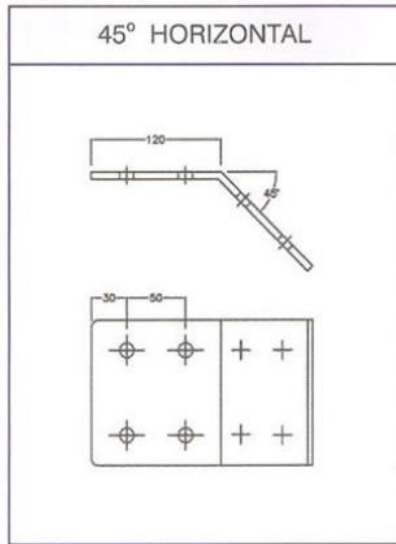
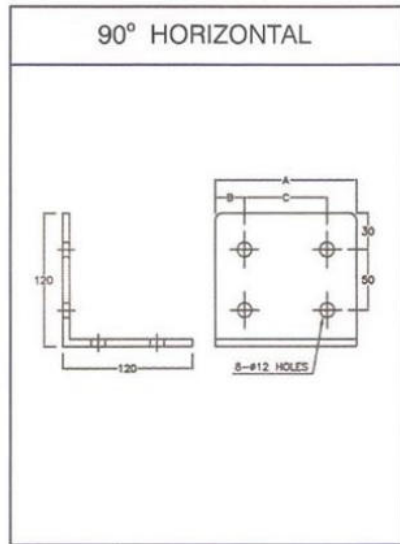

| Siderail Height | Typical Dimension - mm |    |    |
|-----------------|------------------------|----|----|
|                 | A                      | B  | C  |
| 75              | 62                     | 31 | 0  |
| 100             | 62                     | 31 | 0  |
| 150             | 120                    | 25 | 70 |
| 216             | 150                    | 35 | 80 |

\* Use 150mm Siderail Height Dimensions for the 45° and 30° Vertical and Adjustable Splice Plates.

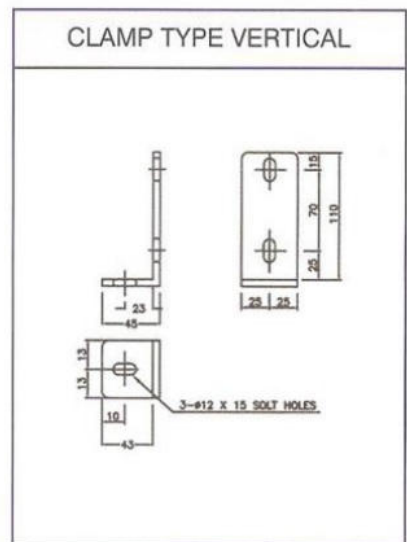
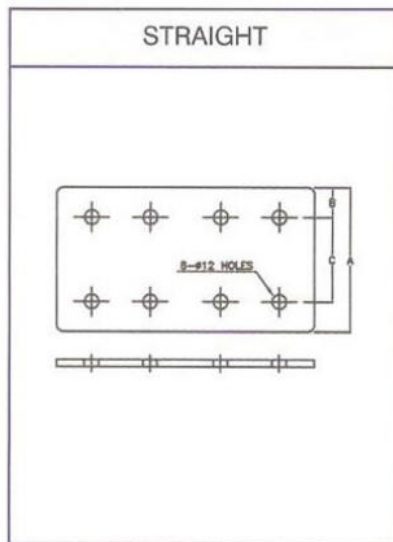
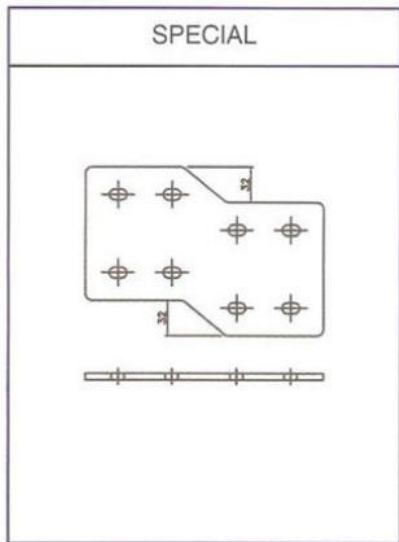
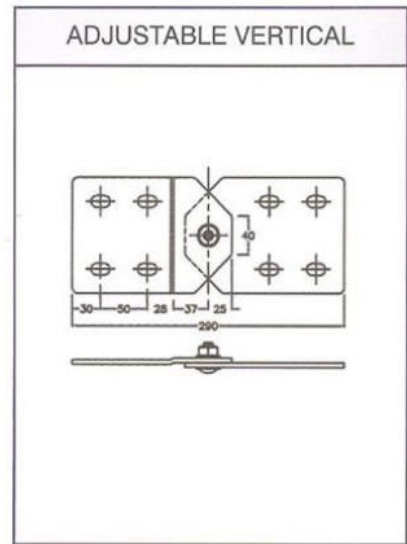
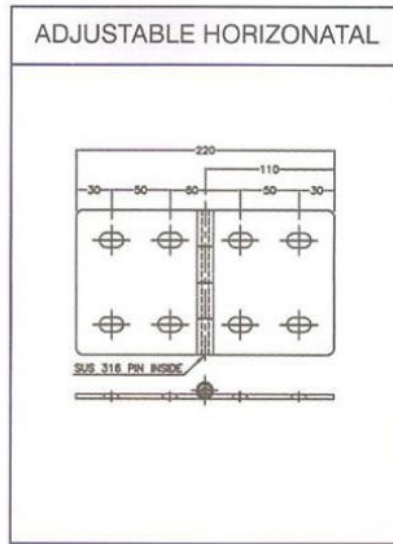
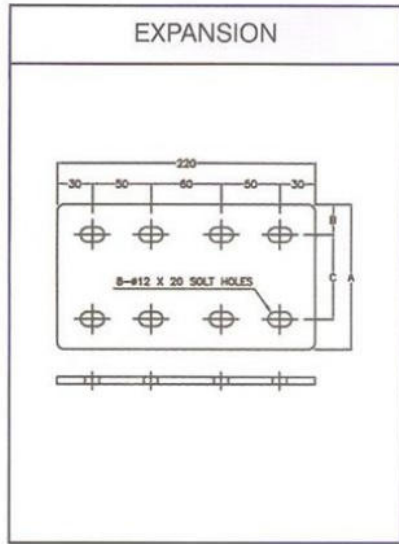

| Siderail Height | Typical Dimension - mm |    |    |
|-----------------|------------------------|----|----|
|                 | A                      | B  | C  |
| 75              | 62                     | 31 | 0  |
| 100             | 62                     | 31 | 0  |
| 150             | 120                    | 25 | 70 |
| 216             | 150                    | 35 | 80 |

\* Use 150mm Siderail Height Dimensions for the 45° and 30° Vertical and Adjustable Splice Plates.

## CABLE TRAY ACCESSORIES

### BARRIER

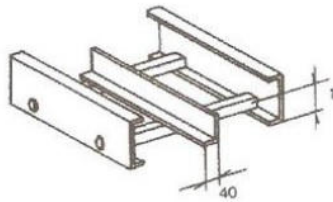

| TRAY TYPE  | CATALOG NO. |
|------------|-------------|
| Polyester  | ABR-UP      |
| Vinylester | ABR-VE      |

Refer to the Fitting Section for ordering factory installed dividers for pre-assembled fittings.

Barrier is supplies in ten foot lengths. Unless indicated otherwise, barriers are intended for field installation.

For securing barriers to tray we recommend the use of thermoplastic drive rivets which require field drilling.

### HOLD DOWN CLAMP

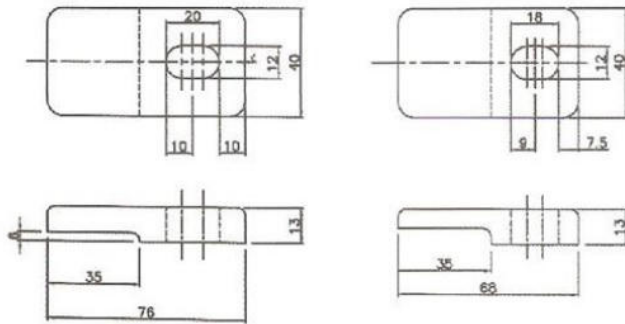

| TRAY TYPE  | CATALOG NO. |
|------------|-------------|
| Polyester  | AHDC-A/B-UP |
| Vinylester | AHDC-A/B-VE |

### BLIND END

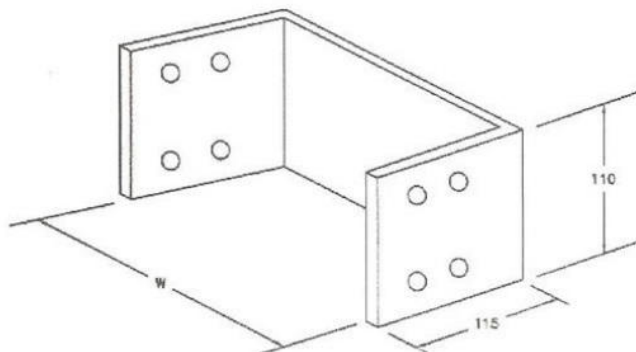

| TRAY TYPE  | CATALOG NO. |
|------------|-------------|
| Polyester  | ABE-UP      |
| Vinylester | ABE-VE      |

## DROP OUT

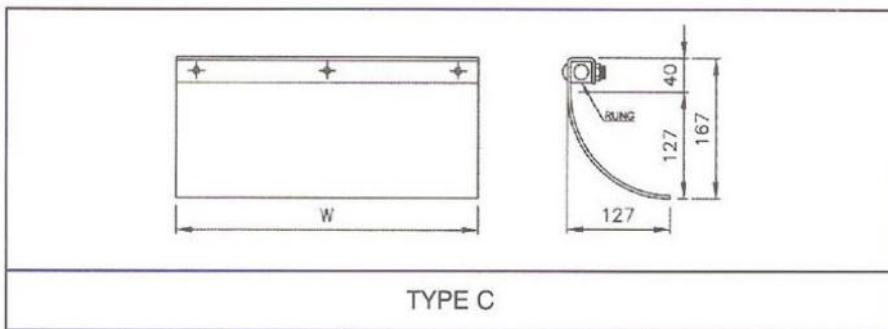
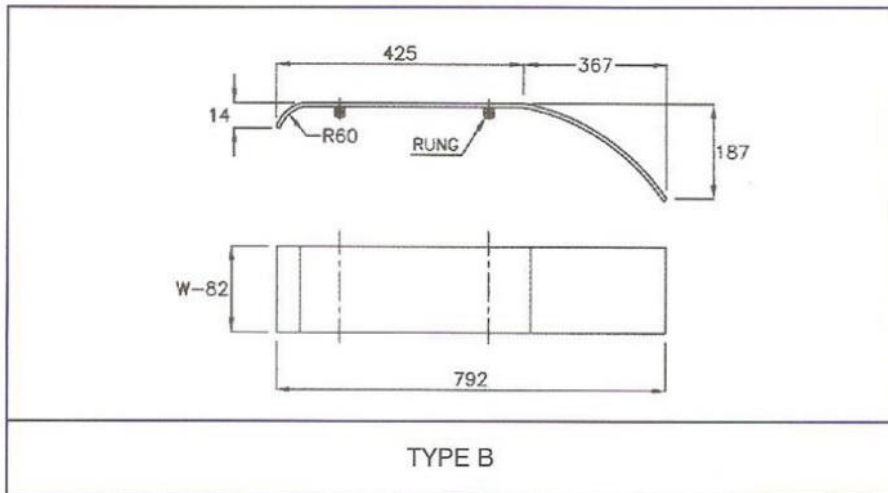
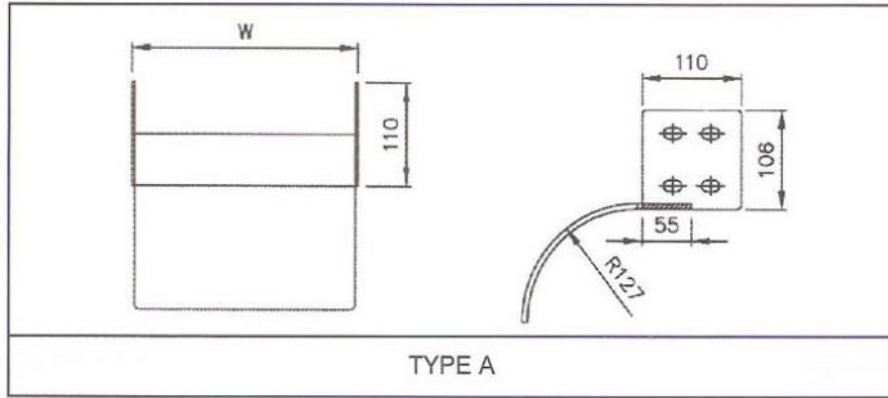

| TRAY TYPE  | CATALOG NO.  |
|------------|--------------|
| Polyester  | ADO-A/B/C-UP |
| Vinylester | ADO-A/B/C-VE |
| SUS 316    | ADO-A/B/C-SS |

## CHANNEL TYPE INSTRUMENTATION TRAYS

### Description

**AB.Cope** Channel Type Instrumentation Trays is designed for any power, communication or control system. It can also be used to support individual wiring, hydraulic or pneumatic tubing.

The pultrusion process offers high strength to weight ratios as well as the ability to manufacture long lengths of the channel type instrumentation trays.

As illustrated, it is offered in solid or ventilated construction.

All straight sections and pre-assembled fittings are pre-drilled to accept flange splice plates. All splice plates and fasteners are separate order items.

### Application

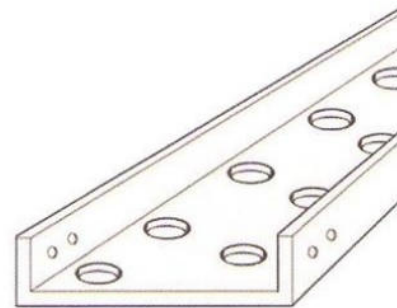
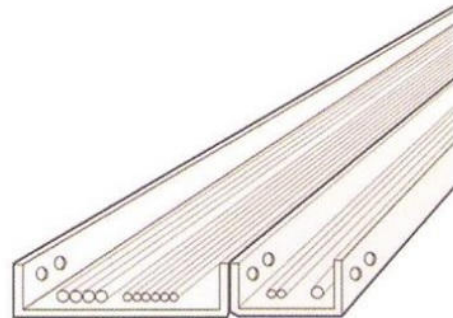

## STRAIGHT SECTIONS

| HEIGHT (mm) | WIDTH (mm) | CATALOG NO.      |                  |
|-------------|------------|------------------|------------------|
|             |            | SOLID            | VENTILATED       |
| 45          | 50         | AIS-50 X L -RS   | AIP-50 X L -RS   |
|             | 100        | AIS-100 X L -RS  | AIP-100 X L -RS  |
|             | 150        | AIS-150 X L -RS  | AIP-150 X L -RS  |
|             | 200        | AIS-200 X L -RS  | AIP-200 X L -RS  |
| 50          | 50         | AIS-50A X L -RS  | AIP-50A X L -RS  |
|             | 100        | AIS-100A X L -RS | AIP-100A X L -RS |
|             | 150        | AIS-150A X L -RS | AIP-150A X L -RS |
|             | 200        | AIS-200A X L -RS | AIP-200A X L -RS |
|             | 300        | AIS-300A X L -RS | AIP-300A X L -RS |
| 75          | 100        | AIS-100B X L -RS | AIP-100B X L -RS |
|             | 150        | AIS-150B X L -RS | AIP-150B X L -RS |

Available in polyester and vinylester resin type in 3M and 6M sections. If vinylester resin is requested and designation as in the following example **WIS-50 X 3000-VE**

CHANNEL TYPE INSTRUMENTATION TRAY LOADING TABLE

| CATALOG NO.        | CHANNEL SIZE | SPAN(M) | MAX LOADING(KG/M) | MAX DEFLECTION(MM) |
|--------------------|--------------|---------|-------------------|--------------------|
| AIS-50 X L -RS     | 50 X 45      | 1.5     | 7.7               | 12.5               |
| AIS- 100 X L -RS   | 100 X 45     | 2.0     | 9.2               | 16.6               |
| AIS- 150 X L -RS   | 150 X 45     | 3.0     | 5.6               | 25                 |
| AIS- 200 X L -RS   | 200 X 45     | 3.0     | 6.5               | 25                 |
| AIS- 50A X L -RS   | 50 X 50      | 1.5     | 8.6               | 12.5               |
| AIS- 100A X L - RS | 100 X 50     | 2.0     | 10.1              | 16.6               |
| AIS- 150A X L -RS  | 150 X 50     | 3.0     | 6.6               | 25                 |
| AIS-200A X L -RS   | 200X 50      | 3.0     | 7.4               | 25                 |
| AIS-300A X L -RS   | 300 X 50     | 3.0     | 5.9               | 25                 |
| AIS- 100B XL -RS   | 100 X 75     | 2.0     | 8.3               | 16.6               |
| AIS- 150B X L -RS  | 150 X 75     | 3.0     | 8.3               | 25                 |

The loads on table are based on limiting the deflection at the value equal to 1/20<sup>th</sup> of the span.

# AB-COPE-GLAS CABLE TRAY SYSTEM

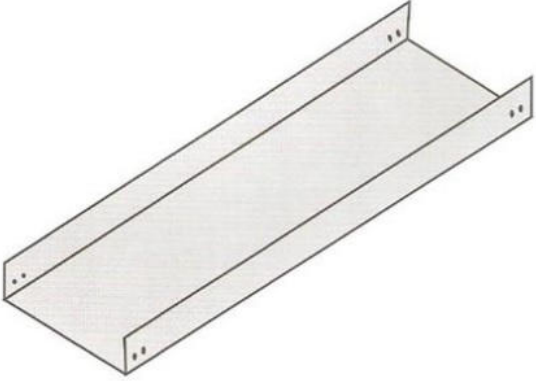
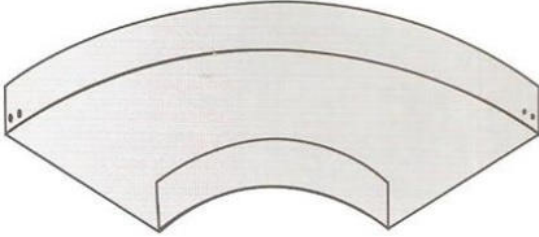
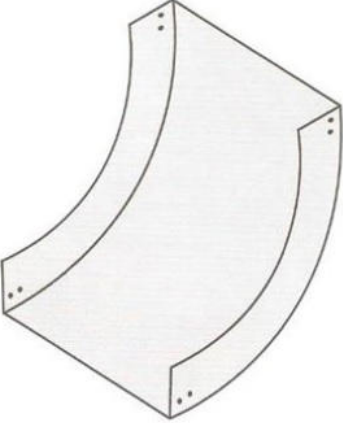
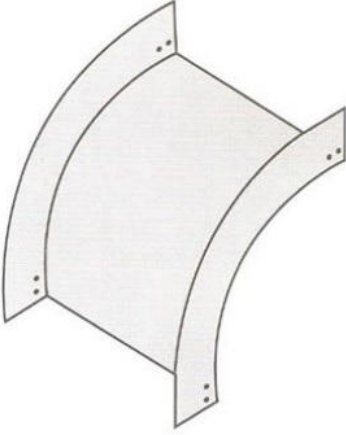
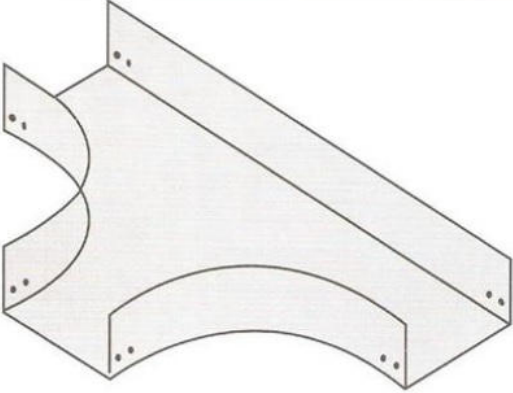
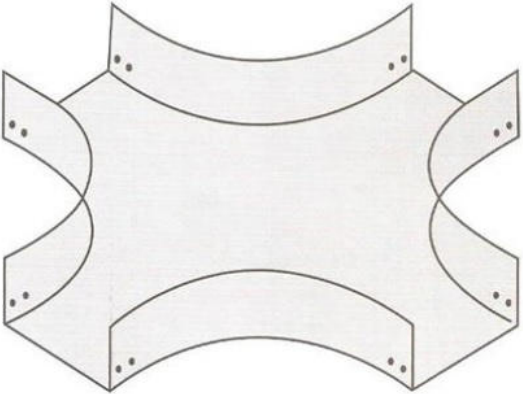
| STRAIGHT SECTION  | HORIZONTAL ELBOW   |
|---|--|
|    |    |
| VERTICAL INSIDE ELBOW   | VERTICAL OUTSIDE ELBOW   |
|   |   |
| HORIZONTAL TEE  | HORIZONTAL CROSS   |
|  |  |

## CONCENTRIC CURVED MOLDED FITTINGS

### 90° HORIZONTAL ELBOW

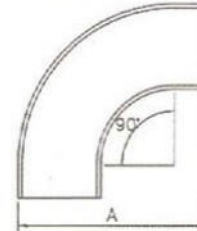
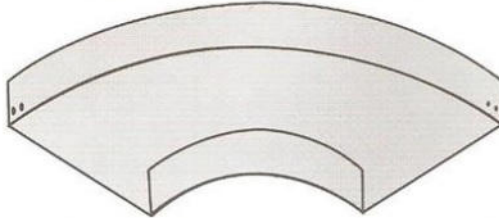

| CATALOG NO.         | RADIUS | A   |
|---------------------|--------|-----|
| AIS-50 - 90HE-300   | 300    | 464 |
| AIS-50A - 90HE-300  |        | 456 |
| AIS-100 - 90HE-300  |        | 514 |
| AIS-100A - 90HE-300 |        | 506 |
| AIS-100B - 90HE-300 |        | 500 |
| AIS-150 - 90EH-300  |        | 565 |
| AIS-150A - 90HE-300 |        | 556 |
| AIS-150B - 90HE-300 |        | 550 |
| AIS-200 - 90HE-300  |        | 616 |
| AIS-200A - 90HE-300 |        | 606 |
| AIS-300A - 90HE-300 |        | 706 |

NOTE: - Substitute "P" in place of "S" for punched channel.  
 - Substitute "30" "45" or "60" in place of "90" for 30°, 45°, 60° Horizontal Elbow.

| CATALOG NO.         | RADIUS | A    |
|---------------------|--------|------|
| AIS-50 - 90HE-600   | 600    | 764  |
| AIS-50A - 90HE-600  |        | 756  |
| AIS-100 - 90HE-600  |        | 814  |
| AIS-100A - 90HE-600 |        | 806  |
| AIS-100B - 90HE-600 |        | 800  |
| AIS-150 - 90EH-600  |        | 865  |
| AIS-150A - 90HE-600 |        | 856  |
| AIS-150B - 90HE-600 |        | 850  |
| AIS-200 - 90HE-600  |        | 916  |
| AIS-200A - 90HE-600 |        | 906  |
| AIS-300A - 90HE-600 |        | 1006 |

NOTE: - Substitute "P" in place of "S" for punched channel.  
 - Substitute "30" "45" or "60" in place of "90" for 30°, 45°, 60° Horizontal Elbow.

### 90° VERTICAL INSIDE

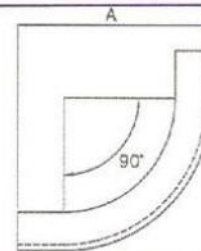
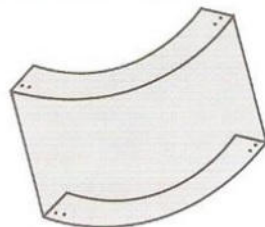

| CATALOG NO.       | RADIUS | A   |
|-------------------|--------|-----|
| AIS-50 90VI-300   | 300    | 445 |
| AIS-50A 90VI-300  |        | 450 |
| AIS-100 90VI-300  |        | 445 |
| AIS-100A 90VI-300 |        | 450 |
| AIS-100B 90VI-300 |        | 475 |
| AIS-150 90VI-300  |        | 445 |
| AIS-150A 90VI-300 |        | 450 |
| AIS-150B 90VI-300 |        | 475 |
| AIS-200 90VI-300  |        | 445 |
| AIS-200A 90VI-300 |        | 450 |
| AIS-300A 90VI-300 |        | 450 |

NOTE: - Substitute "P" in place of "S" for punched channel.  
 - Substitute "30" "45" or "60" in place of "90" for 30°, 45°, 60° Horizontal Elbow.

| CATALOG NO.       | RADIUS | A   |
|-------------------|--------|-----|
| AIS-50 90VI-600   | 600    | 745 |
| AIS-50A 90VI-600  |        | 750 |
| AIS-100 90VI-600  |        | 745 |
| AIS-100A 90VI-600 |        | 750 |
| AIS-100B 90VI-600 |        | 775 |
| AIS-150 90VI-600  |        | 745 |
| AIS-150A 90VI-600 |        | 750 |
| AIS-150B 90VI-600 |        | 775 |
| AIS-200 90VI-600  |        | 745 |
| AIS-200A 90VI-600 |        | 750 |
| AIS-300A 90VI-600 |        | 750 |

NOTE: - Substitute "P" in place of "S" for punched channel.  
 - Substitute "30" "45" or "60" in place of "90" for 30°, 45°, 60° Horizontal Elbow.

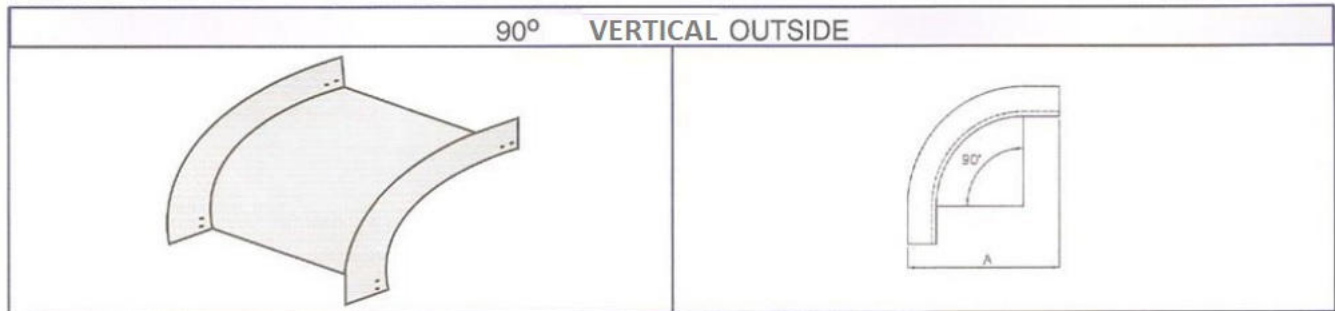

| CATALOG NO.         | RADIUS | A   |
|---------------------|--------|-----|
| AIS-50 - 90VO-300   | 300    | 445 |
| AIS-50A - 90VO-300  |        | 450 |
| AIS-100 - 90VO-300  |        | 445 |
| AIS-100A - 90VO-300 |        | 450 |
| AIS-100B - 90VO-300 |        | 475 |
| AIS-150 - 90VO-300  |        | 445 |
| AIS-150A - 90VO-300 |        | 450 |
| AIS-150B - 90VO-300 |        | 475 |
| AIS-200 - 90VO-300  |        | 445 |
| AIS-200A - 90VO-300 |        | 450 |
| AIS-300A - 90VO-300 |        | 450 |

| CATALOG NO.         | RADIUS | A   |
|---------------------|--------|-----|
| AIS-50 - 90VO-600   | 600    | 745 |
| AIS-50A - 90VO-600  |        | 750 |
| AIS-100 - 90VO-600  |        | 745 |
| AIS-100A - 90VO-600 |        | 750 |
| AIS-100B - 90VO-600 |        | 775 |
| AIS-150 - 90VO-600  |        | 745 |
| AIS-150A - 90VO-600 |        | 750 |
| AIS-150B - 90VO-600 |        | 775 |
| AIS-200 - 90VO-600  |        | 745 |
| AIS-200A - 90VO-600 |        | 750 |
| AIS-300A - 90VO-600 |        | 750 |

NOTE: - Substitute "P" in place of "S" for punched channel.  
 - Substitute "30" "45" or "60" in place of "90" for 30°, 45°, 60° Horizontal Elbow.

NOTE: - Substitute "P" in place of "S" for punched channel.  
 - Substitute "30" "45" or "60" in place of "90" for 30°, 45°, 60° Horizontal Elbow.



| CATALOG NO.     | RADIUS | W1  | W2  |
|-----------------|--------|-----|-----|
| AIS-50-HT-300   | 300    | 51  | 51  |
| AIS-50A-HT-300  |        | 50  | 50  |
| AIS-100-HT-300  |        | 102 | 102 |
| AIS-100A-HT-300 |        | 100 | 100 |
| AIS-100B-HT-300 |        | 88  | 88  |
| AIS-150-HT-300  |        | 152 | 152 |
| AIS-150A-HT-300 |        | 150 | 150 |
| AIS-150B-HT-300 |        | 138 | 138 |
| AIS-200-HT-300  |        | 203 | 203 |
| AIS-200A-HT-300 |        | 200 | 200 |
| AIS-300A-HT-300 |        | 300 | 300 |

| CATALOG NO.     | RADIUS | W1  | W2  |
|-----------------|--------|-----|-----|
| AIS-50-HT-600   | 600    | 51  | 51  |
| AIS-50A-HT-600  |        | 50  | 50  |
| AIS-100-HT-600  |        | 102 | 102 |
| AIS-100A-HT-600 |        | 100 | 100 |
| AIS-100B-HT-600 |        | 88  | 88  |
| AIS-150-HT-600  |        | 152 | 152 |
| AIS-150A-HT-600 |        | 150 | 150 |
| AIS-150B-HT-600 |        | 138 | 138 |
| AIS-200-HT-600  |        | 203 | 203 |
| AIS-200A-HT-600 |        | 200 | 200 |
| AIS-300A-HT-600 |        | 300 | 300 |

NOTE: - Substitute "P" in place of "S" for punched channel.

NOTE: - Substitute "P" in place of "S" for punched channel.

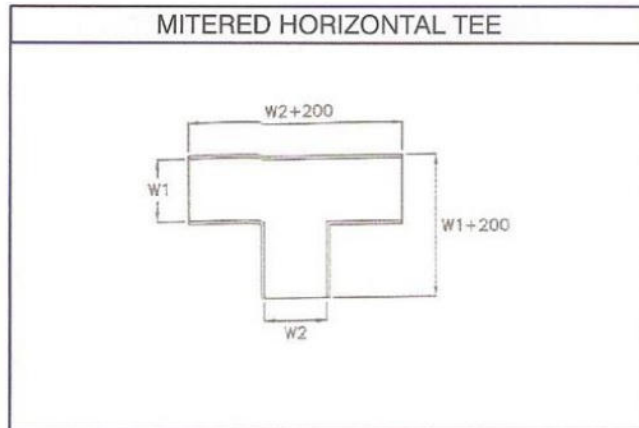

| CATALOG NO. | W1  | W2  |
|-------------|-----|-----|
| AIS-HT-50   | 51  | 51  |
| AIS-HT-50A  | 50  | 50  |
| AIS-HT-100  | 102 | 102 |
| AIS-HT-100A | 100 | 100 |
| AIS-HT-100B | 88  | 88  |
| AIS-HT-150  | 152 | 152 |
| AIS-HT-150A | 150 | 150 |
| AIS-HT-150B | 138 | 138 |
| AIS-HT-200  | 203 | 203 |
| AIS-HT-200A | 200 | 200 |
| AIS-HT-300A | 300 | 300 |

NOTE: - Substitute "P" in place of "S" for punched channel.

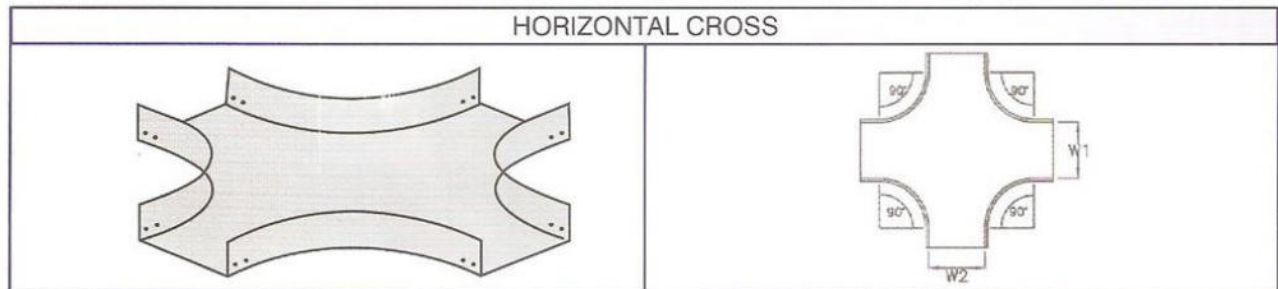

| CATALOG NO.     | RADIUS | W1  | W2  |
|-----------------|--------|-----|-----|
| AIS-50-HC-300   | 300    | 51  | 51  |
| AIS-50A-HC-300  |        | 50  | 50  |
| AIS-100-HC-300  |        | 102 | 102 |
| AIS-100A-HC-300 |        | 100 | 100 |
| AIS-100B-HC-300 |        | 88  | 88  |
| AIS-150-HC-300  |        | 152 | 152 |
| AIS-150A-HC-300 |        | 150 | 150 |
| AIS-150B-HC-300 |        | 138 | 138 |
| AIS-200-HC-300  |        | 203 | 203 |
| AIS-200A-HC-300 |        | 200 | 200 |
| AIS-300A-HC-300 |        | 300 | 300 |

NOTE: - Substitute "P" in place of "S" for punched channel.

| CATALOG NO.     | RADIUS | W1  | W2  |
|-----------------|--------|-----|-----|
| AIS-50-HC-600   | 600    | 51  | 51  |
| AIS-50A-HC-600  |        | 50  | 50  |
| AIS-100-HC-600  |        | 102 | 102 |
| AIS-100A-HC-600 |        | 100 | 100 |
| AIS-100B-HC-600 |        | 88  | 88  |
| AIS-150-HC-600  |        | 152 | 152 |
| AIS-150A-HC-600 |        | 150 | 150 |
| AIS-150B-HC-600 |        | 138 | 138 |
| AIS-200-HC-600  |        | 203 | 203 |
| AIS-200A-HC-600 |        | 200 | 200 |
| AIS-300A-HC-600 |        | 300 | 300 |

NOTE: - Substitute "P" in place of "S" for punched channel.

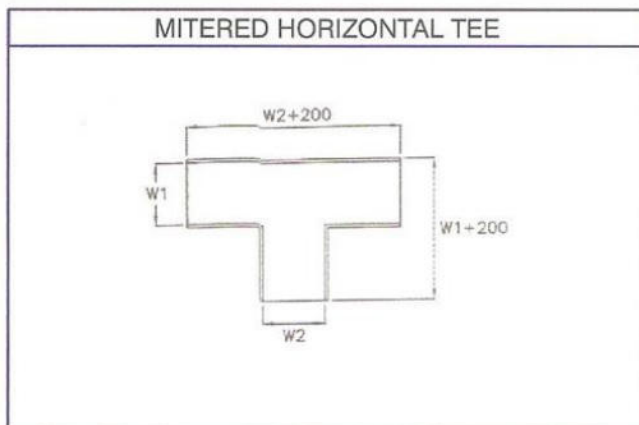

| CATALOG NO. | W1  | W2  |
|-------------|-----|-----|
| AIS-HC-50   | 51  | 51  |
| AIS-HC-50A  | 50  | 50  |
| AIS-HC-100  | 102 | 102 |
| AIS-HC-100A | 100 | 100 |
| AIS-HC-100B | 88  | 88  |
| AIS-HC-150  | 152 | 152 |
| AIS-HC-150A | 150 | 150 |
| AIS-HC-150B | 138 | 138 |
| AIS-HC-200  | 203 | 203 |
| AIS-HC-200A | 200 | 200 |
| AIS-HC-300A | 300 | 300 |

NOTE: - Substitute "P" in place of "S" for punched channel.

## COVERS / COVER CLAMPS

### Flanged Type



Catalog No.: AICF - (Width) - RS - L

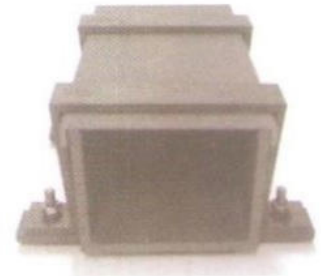
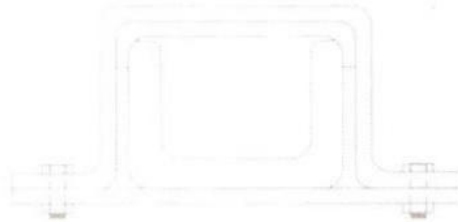

Catalog No.: AICMC - (Width)

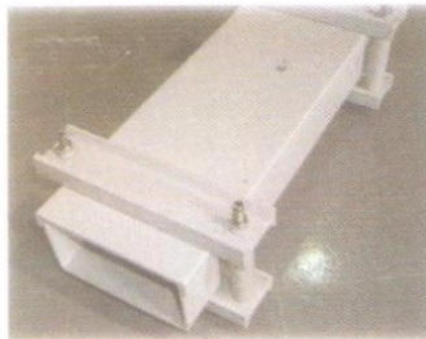

Catalog No.: AICIC - (Width)

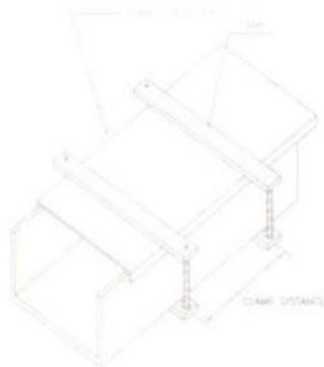

Catalog No.: AICFC - (Width)

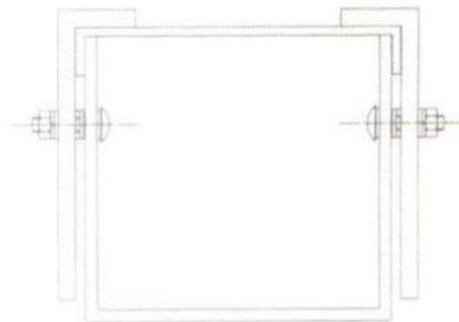

Catalog No.: AICLC

## FITTING COVERS

|                             |                              |
|-----------------------------|------------------------------|
| HORIZONTAL ELBOW COVER      |                              |
|                             |                              |
| VERTICAL INSIDE ELBOW COVER | VERTICAL OUTSIDE ELBOW COVER |
|                             |                              |
| HORIZONTAL TEE COVER        | HORIZONTAL CROSS COVER       |
|                             |                              |

## CONCENTRIC CURVED MOLDED FITTINGS COVERS



| CATALOG NO.         | RADIUS | A   |
|---------------------|--------|-----|
| AIC-50 - 90HE-300   | 300    | 472 |
| AIC-50A - 90HE-300  |        | 464 |
| AIC-100 - 90HE-300  |        | 522 |
| AIC-100A - 90HE-300 |        | 514 |
| AIC-100B - 90HE-300 |        | 508 |
| AIC-150 - 90HE-300  |        | 573 |
| AIC-150A - 90HE-300 |        | 564 |
| AIC-150B - 90HE-300 |        | 558 |
| AIC-200 - 90HE-300  |        | 624 |
| AIC-200A - 90HE-300 |        | 614 |
| AIC-300A - 90HE-300 |        | 714 |

NOTE: - Substitute "30°" "45°" or "60°" in place of "90°" for 30°, 45° or 60° Horizontal Elbow Cover.

| CATALOG NO.         | RADIUS | A    |
|---------------------|--------|------|
| AIC-50 - 90HE-600   | 600    | 772  |
| AIC-50A - 90HE-600  |        | 764  |
| AIC-100 - 90HE-600  |        | 822  |
| AIC-100A - 90HE-600 |        | 814  |
| AIC-100B - 90HE-600 |        | 808  |
| AIC-150 - 90HE-600  |        | 873  |
| AIC-150A - 90HE-600 |        | 864  |
| AIC-150B - 90HE-600 |        | 858  |
| AIC-200 - 90HE-600  |        | 924  |
| AIC-200A - 90HE-600 |        | 914  |
| AIC-300A - 90HE-600 |        | 1014 |

NOTE: - Substitute "30°" "45°" or "60°" in place of "90°" for 30°, 45° or 60° Horizontal Elbow Cover.

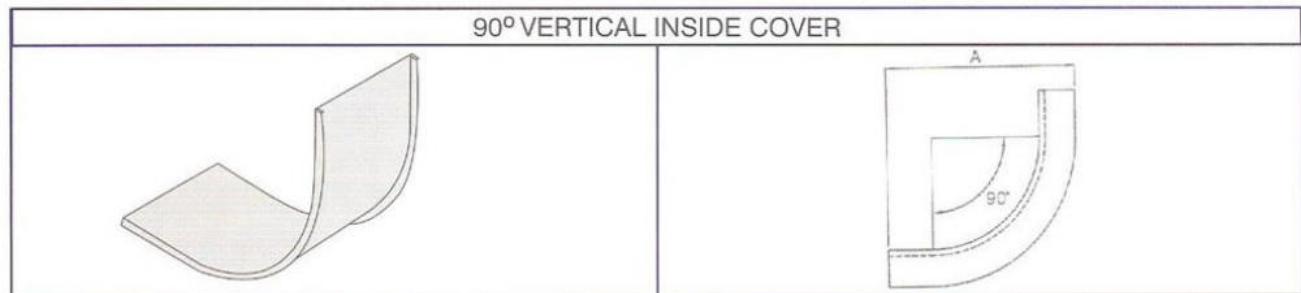

| CATALOG NO.         | RADIUS | A   |
|---------------------|--------|-----|
| AIC-50 - 90VI-300   | 300    | 413 |
| AIC-50A - 90VI-300  |        | 413 |
| AIC-100 - 90VI-300  |        | 413 |
| AIC-100A - 90VI-300 |        | 413 |
| AIC-100B - 90VI-300 |        | 413 |
| AIC-150 - 90VI-300  |        | 413 |
| AIC-150A - 90HE-300 |        | 413 |
| AIC-150B - 90HE-300 |        | 413 |
| AIC-200 - 90HE-300  |        | 413 |
| AIC-200A - 90HE-300 |        | 413 |
| AIC-300A - 90HE-300 |        | 413 |

NOTE: - Substitute "30°" "45°" or "60°" in place of "90°" for 30°, 45° or 60° Vertical Inside Cover.

| CATALOG NO.         | RADIUS | A   |
|---------------------|--------|-----|
| AIC-50 - 90VI-600   | 600    | 713 |
| AIC-50A - 90VI-600  |        | 713 |
| AIC-100 - 90VI-600  |        | 713 |
| AIC-100A - 90VI-600 |        | 713 |
| AIC-100B - 90VI-600 |        | 713 |
| AIC-150 - 90VI-600  |        | 713 |
| AIC-150A - 90VI-600 |        | 713 |
| AIC-150B - 90VI-600 |        | 713 |
| AIC-200 - 90VI-600  |        | 713 |
| AIC-200A - 90VI-600 |        | 713 |
| AIC-300A - 90VI-600 |        | 713 |

NOTE: - Substitute "30°" "45°" or "60°" in place of "90°" for 30°, 45° or 60° Vertical Inside Cover.

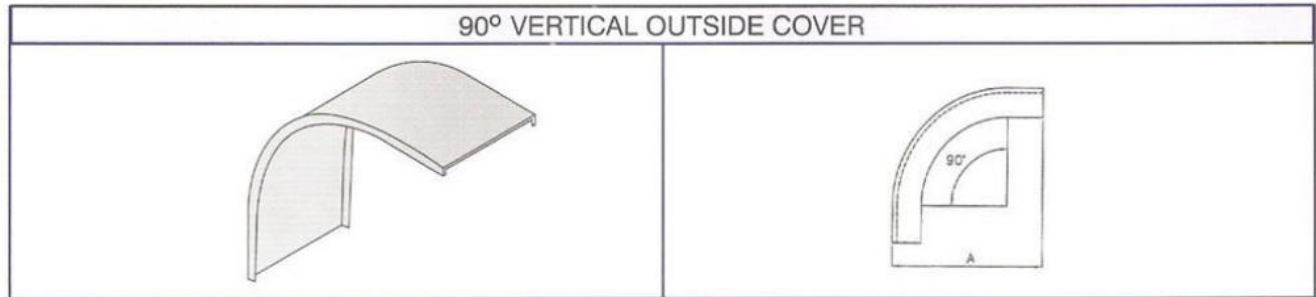

| CATALOG NO.         | RADIUS | A   |
|---------------------|--------|-----|
| AIC-50 - 90VO-300   | 300    | 413 |
| AIC-50A - 90VO-300  |        | 413 |
| AIC-100 - 90VO-300  |        | 413 |
| AIC-100A - 90VO-300 |        | 413 |
| AIC-100B - 90VO-300 |        | 413 |
| AIC-150 - 90VO-300  |        | 413 |
| AIC-150A - 90VO-300 |        | 413 |
| AIC-150B - 90VO-300 |        | 413 |
| AIC-200 - 90VO-300  |        | 413 |
| AIC-200A - 90VO-300 |        | 413 |
| AIC-300A - 90VO-300 |        | 413 |

| CATALOG NO.         | RADIUS | A   |
|---------------------|--------|-----|
| AIC-50 - 90VO-600   | 600    | 713 |
| AIC-50A - 90VO-600  |        | 713 |
| AIC-100 - 90VO-600  |        | 713 |
| AIC-100A - 90VO-600 |        | 713 |
| AIC-100B - 90VO-600 |        | 713 |
| AIC-150 - 90VO-600  |        | 713 |
| AIC-150A - 90VO-600 |        | 713 |
| AIC-150B - 90VO-600 |        | 713 |
| AIC-200 - 90VO-600  |        | 713 |
| AIC-200A - 90VO-600 |        | 713 |
| AIC-300A - 90VO-600 |        | 713 |

NOTE: - Substitute "30°" "45°" or "60°" in place of "90°" for 30°, 45° or 60° Vertical Outside Cover.

NOTE: - Substitute "30°" "45°" or "60°" in place of "90°" for 30°, 45° or 60° Vertical Outside Cover.



| CATALOG NO.       | RADIUS | W1  | W2  |
|-------------------|--------|-----|-----|
| AIC-50 - HT-300   | 300    | 51  | 51  |
| AIC-50A - HT-300  |        | 50  | 50  |
| AIC-100 - HT-300  |        | 102 | 102 |
| AIC-100A - HT-300 |        | 100 | 100 |
| AIC-100B - HT-300 |        | 88  | 88  |
| AIC-150 - HT-300  |        | 152 | 152 |
| AIC-150A - HT-300 |        | 150 | 150 |
| AIC-150B - HT-300 |        | 138 | 138 |
| AIC-200 - HT-300  |        | 203 | 203 |
| AIC-200A - HT-300 |        | 200 | 200 |
| AIC-300A - HT-300 |        | 300 | 300 |

| CATALOG NO.       | RADIUS | W1  | W2  |
|-------------------|--------|-----|-----|
| AIC-50 - HT-600   | 600    | 51  | 51  |
| AIC-50A - HT-600  |        | 50  | 50  |
| AIC-100 - HT-600  |        | 102 | 102 |
| AIC-100A - HT-600 |        | 100 | 100 |
| AIC-100B - HT-600 |        | 88  | 88  |
| AIC-150 - HT-600  |        | 152 | 152 |
| AIC-150A - HT-600 |        | 150 | 150 |
| AIC-150B - HT-600 |        | 138 | 138 |
| AIC-200 - HT-600  |        | 203 | 203 |
| AIC-200A - HT-600 |        | 200 | 200 |
| AIC-300A - HT-600 |        | 300 | 300 |

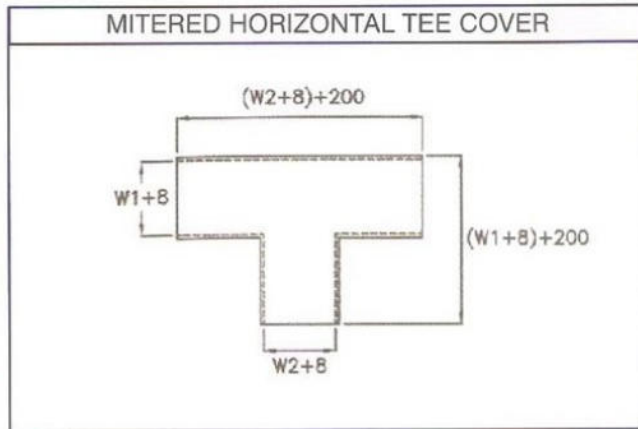

| CATALOG NO. | W1  | W2  |
|-------------|-----|-----|
| AIC-HT-50   | 51  | 51  |
| AIC-HT-50A  | 50  | 50  |
| AIC-HT-100  | 102 | 102 |
| AIC-HT-100A | 100 | 100 |
| AIC-HT-100B | 88  | 88  |
| AIC-HT-150  | 152 | 152 |
| AIC-HT-150A | 150 | 150 |
| AIC-HT-150B | 138 | 138 |
| AIC-HT-200  | 203 | 203 |
| AIC-HT-200A | 200 | 200 |
| AIC-HT-300A | 300 | 300 |

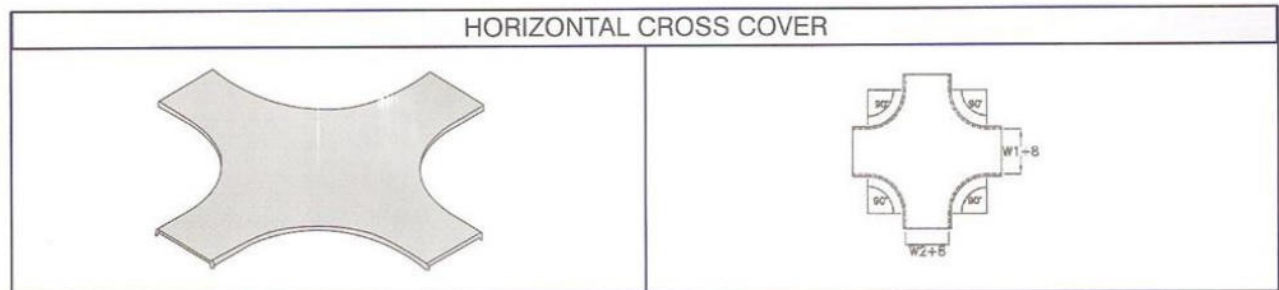

| CATALOG NO.     | RADIUS | W1  | W2  |
|-----------------|--------|-----|-----|
| AIC-50-HC-300   | 300    | 51  | 51  |
| AIC-50A-HC-300  |        | 50  | 50  |
| AIC-100-HC-300  |        | 102 | 102 |
| AIC-100A-HC-300 |        | 100 | 100 |
| AIC-100B-HC-300 |        | 88  | 88  |
| AIC-150-HC-300  |        | 152 | 152 |
| AIC-150A-HC-300 |        | 150 | 150 |
| AIC-150B-HC-300 |        | 138 | 138 |
| AIC-200-HC-300  |        | 203 | 203 |
| AIC-200A-HC-300 |        | 200 | 200 |
| AIC-300A-HC-300 |        | 300 | 300 |

| CATALOG NO.     | RADIUS | W1  | W2  |
|-----------------|--------|-----|-----|
| AIC-50-HC-600   | 600    | 51  | 51  |
| AIC-50A-HC-600  |        | 50  | 50  |
| AIC-100-HC-600  |        | 102 | 102 |
| AIC-100A-HC-600 |        | 100 | 100 |
| AIC-100B-HC-600 |        | 88  | 88  |
| AIC-150-HC-600  |        | 152 | 152 |
| AIC-150A-HC-600 |        | 150 | 150 |
| AIC-150B-HC-600 |        | 138 | 138 |
| AIC-200-HC-600  |        | 203 | 203 |
| AIC-200A-HC-600 |        | 200 | 200 |
| AIC-300A-HC-600 |        | 300 | 300 |

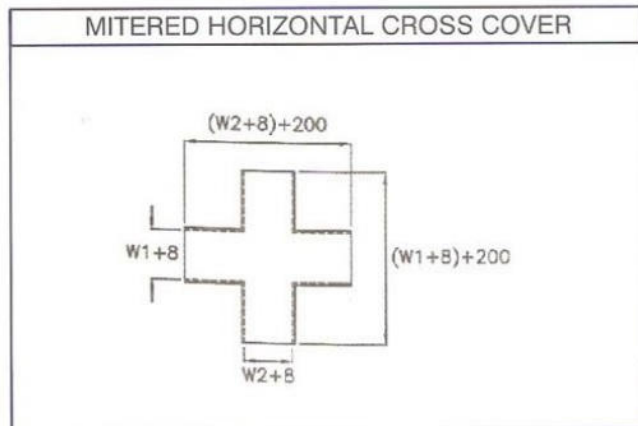

| CATALOG NO. | W1  | W2  |
|-------------|-----|-----|
| AIC-HC-50   | 51  | 51  |
| AIC-HC-50A  | 50  | 50  |
| AIC-HC-100  | 102 | 102 |
| AIC-HC-100A | 100 | 100 |
| AIC-HC-100B | 88  | 88  |
| AIC-HC-150  | 152 | 152 |
| AIC-HC-150A | 150 | 150 |
| AIC-HC-150B | 138 | 138 |
| AIC-HC-200  | 203 | 203 |
| AIC-HC-200A | 200 | 200 |
| AIC-HC-300A | 300 | 300 |

## CHANNEL TRAY "FLANGE" SPLICE PLATES

**AB.Cope** / SUS 316 connector plates and fasteners are sold separately and are not provided standardly with straight sections or preassembled fittings.

All plates have Ø8mm pre-drilled bolt holes.

### CONNECTOR PLATES

| DESCRIPTION    |                     | CONNECTOR/SPLICE PLATE CATALOG NUMBERS |                       |                     |                |                |                |
|----------------|---------------------|--|-----------------------|---------------------|----------------|----------------|----------------|
| Channel Height | Bolt Sets Per Plate | Straight                               | Adjustable Horizontal | Adjustable Vertical | 90° Horizontal | 45° Horizontal | 30° Horizontal |
| 45             | 4                   | AISP-180S-45                           | AISP-AH-45            | AISP-AV-45          | AISP-90H-45    | AISP-45H-45    | AISP-30H-45    |
| 50             | 4                   | AISP-180S-50                           | AISP-AH-50            | AISP-AV-50          | AISP-90H-50    | AISP-45H-50    | AISP-30H-50    |
| 75             | 4                   | AISP-180S-75                           | AISP-AH-75            | AISP-AV-75          | AISP-90H-75z   | AISP-45H-75    | AISP-30H-75    |

| DESCRIPTION     |                     | CONNECTOR/SPLICE PLATE CATALOG NUMBERS |              |              |             |            |                             |
|-----------------|---------------------|--|--------------|--------------|-------------|------------|-----------------------------|
| Siderail Height | Bolt Sets Per Plate | 90° Vertical                           | 45° Vertical | 30° Vertical | Clip Fixxer | Tube Cliip | Clip Fixxer & Tube Clip Set |
| 45              | 4                   | AISP-90V-45                            | AISP-45V-45  | AISP-30V-45  | AISP-CF-45  | AISP-TC-45 | AISP-CTS-45                 |
| 50              | 4                   | AISP-90V-50                            | AISP-45V-50  | AISP-30V-50  | AISP-CF-50  | AISP-TC-50 | AISP-CTS-50                 |
| 75              | 4                   | AISP-90V-75                            | AISP-45V-75  | AISP-30V-75  | AISP-CF-75  | AISP-TC-75 | AISP-CTS-75                 |

### ASSEMBLY FASTENERS

| DESCRIPTION                 | SIZE     | FOR USE WITH CHANNEL HEIGHT | CATALOG NO.    |
|-----------------------------|----------|-----------------------------|----------------|
| TYPE 304<br>STAINLESS STEEL | M6 X 30L | 45, 50, 75                  | AAF-SS304-0630 |
|                             | M6 X 35L |                             | AAF-SS304-0635 |
|                             | M6 X 30L |                             | AAF-SS304-0830 |
|                             | M6 X 50L |                             | AAF-SS304-0850 |
| TYPE 316<br>STAINLESS STEEL | M6 X 30L | 45, 50, 75                  | AAF-SS316-0630 |
|                             | M6 X 35L |                             | AAF-SS316-0635 |
|                             | M8 X 30L |                             | AAF-SS316-0830 |
|                             | M8 X 50L |                             | AAF-SS316-0835 |

Sets Include: \* Bolt/Nut, 2 Flat Washers, 1 Lock Washer

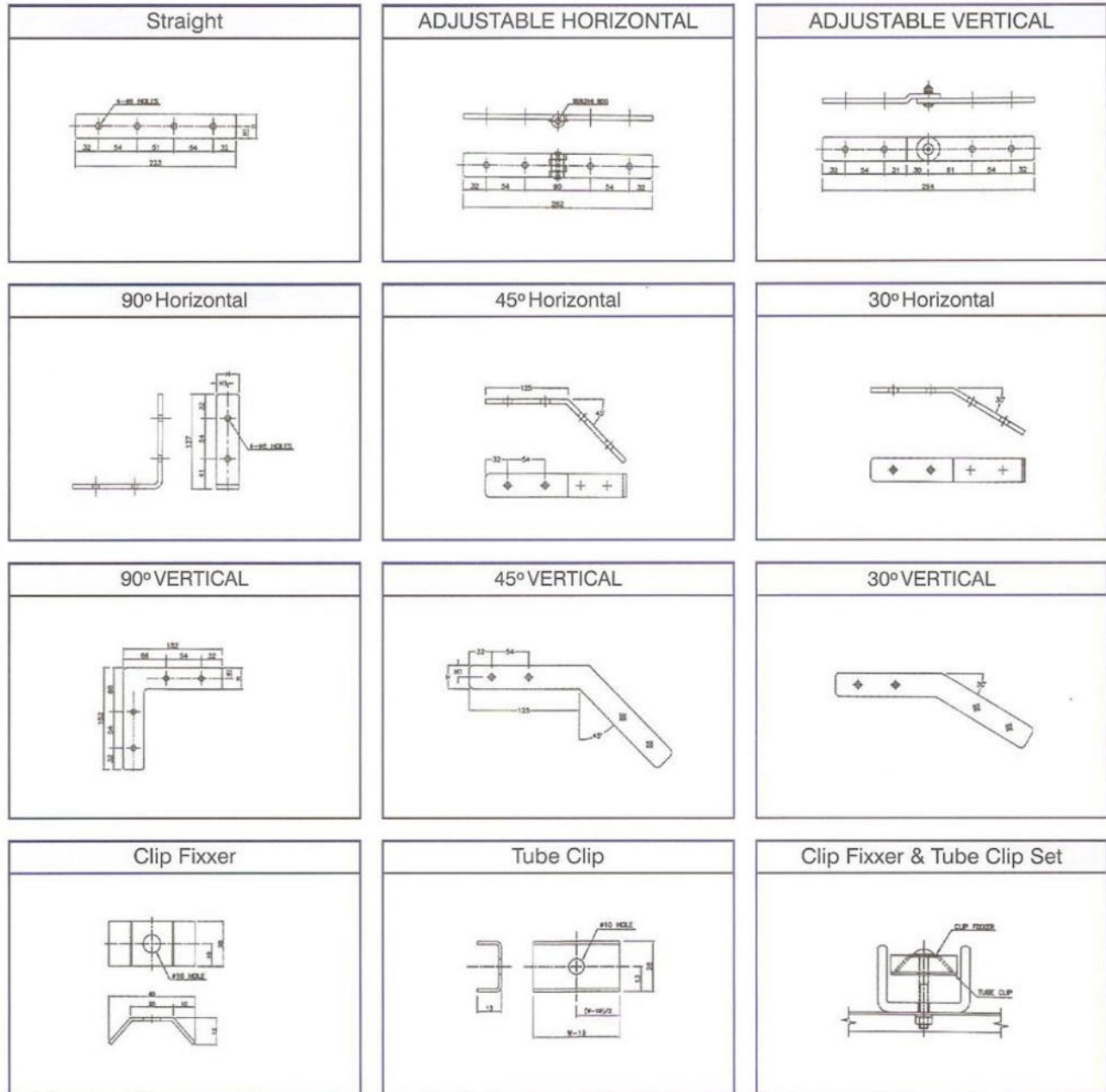

| Channel Height | Typical Dimension - mm |    |
|----------------|------------------------|----|
|                | H                      | H1 |
| 45             | 32                     | 16 |
| 50             | 32                     | 16 |
| 75             | 62                     | 31 |

## WIREWAY SYSTEMS

### Description

**AB.Cope** Cable Tray in GRP Wireway Systems are provided with a "SNAP-ON/OFF" Covers.

It is designed to provide easy installation of any power, communication or control system. The pultrusion process offers high strength to weight ratios as well as the ability to manufacture long lengths of the Wireway Systems; which help to minimize the need for field splicing.

The integral snap together design allows all parts to be hand assembled, saving time and tooling. It also creates an inside surface which is smooth and free from fastener intrusion. This is essential for high voltage and communication cables, which due to vibration of passing trains, could rub and eventually break through.

Normal maintenance is easily accomplished with the snap together system which requires no special tools. With a screwdriver and a tube of silicone, any section of trough can be accessed, repaired and resealed.

### Applications

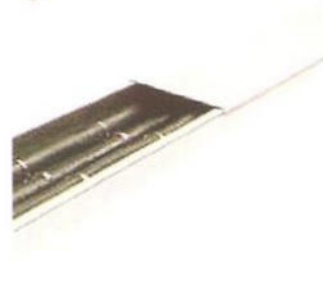
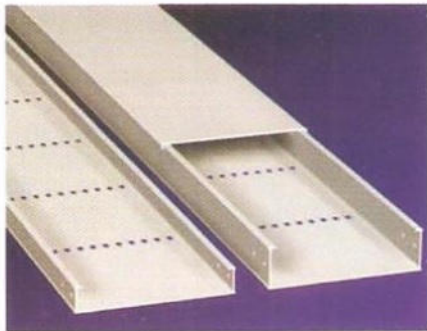

## SNAP-ON/OFF COVER STYLES

### Snap-On/Off Covers

No assembly hardware is required

: minimizing installation time and making access to the cables as easy as opening a door.

#### Type A

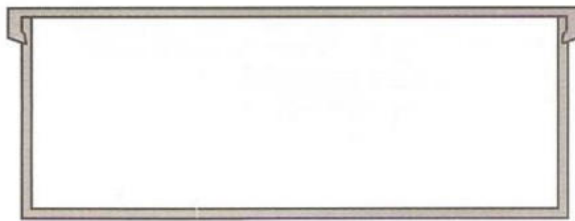

| TRAY TYPE  | CATALOG NO. |
|------------|-------------|
| Polyester  | SO-A-UP     |
| Vinylester | SO-A-VE     |



#### Type B

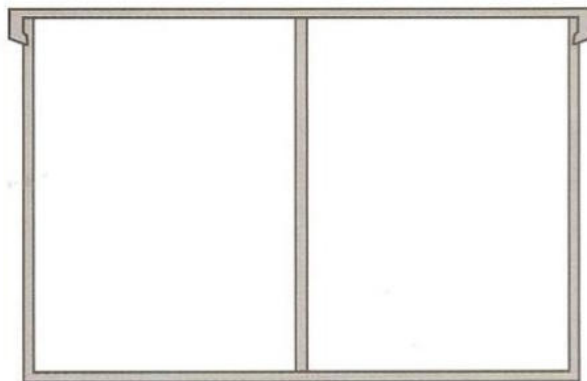

| TRAY TYPE  | CATALOG NO. |
|------------|-------------|
| Polyester  | SO-B-UP     |
| Vinylester | SO-B-VE     |

the divider allows separation of various cables as needed.

## STRAIGHT SECTIONS

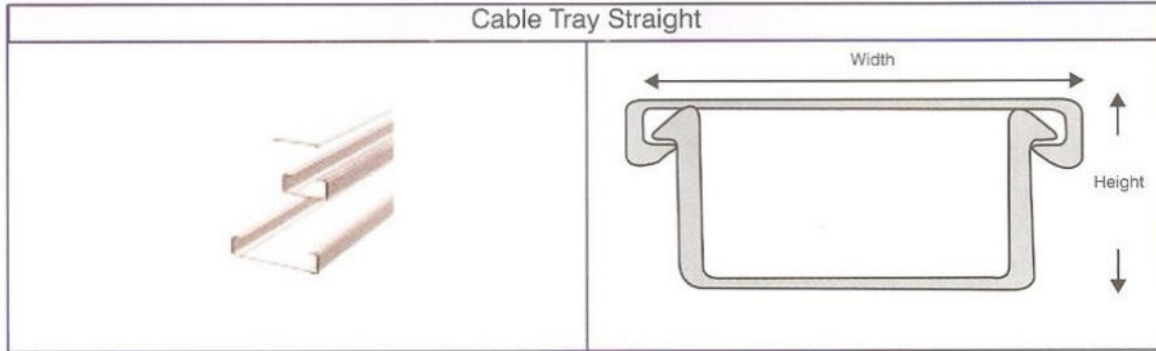

### Cable Tray

| HEIGHT<br>(mm) | WIDTH<br>(mm) | CATALOG NO.        |                    |
|----------------|---------------|--------------------|--------------------|
|                |               | SOLID              | VENTILATED         |
| 50             | 50            | SO-AIS-100 X L -RS | SO-AIP-100 X L -RS |
|                | 100           | SO-AIS-150 X L -RS | SO-AIP-150 X L -RS |
|                | 150           | SO-AIS-200 X L -RS | SO-AIP-200 X L -RS |
|                | 200           | SO-AIS-300 X L -RS | SO-AIP-300 X L -RS |
| 75             | 50            | SO-AIS-100 X L -RS | SO-AIP-100 X L -RS |
|                | 100           | SO-AIS-150 X L -RS | SO-AIP-150 X L -RS |
|                | 150           | SO-AIS-200 X L -RS | SO-AIP-200 X L -RS |
|                | 200           | SO-AIS-300 X L -RS | SO-AIP-300 X L -RS |

Available in polyester and vinylester resin type in 3M and 6M sections. If vinylester resin is requested and designation as in the following example : SO-AIS-100 X 3000-VE

### Cover

| HEIGHT<br>(mm) | WIDTH<br>(mm) | CATALOG NO.        |
|----------------|---------------|--------------------|
|                |               |                    |
| 50             | 50            | SO-AIC-100 X L -RS |
|                | 100           | SO-AIC-150 X L -RS |
|                | 150           | SO-AIC-200 X L -RS |
|                | 200           | SO-AIC-300 X L -RS |
| 75             | 50            | SO-AIC-100 X L -RS |
|                | 100           | SO-AIC-150 X L -RS |
|                | 150           | SO-AIC-200 X L -RS |
|                | 200           | SO-AIC-300 X L -RS |

## FITTING SECTIONS

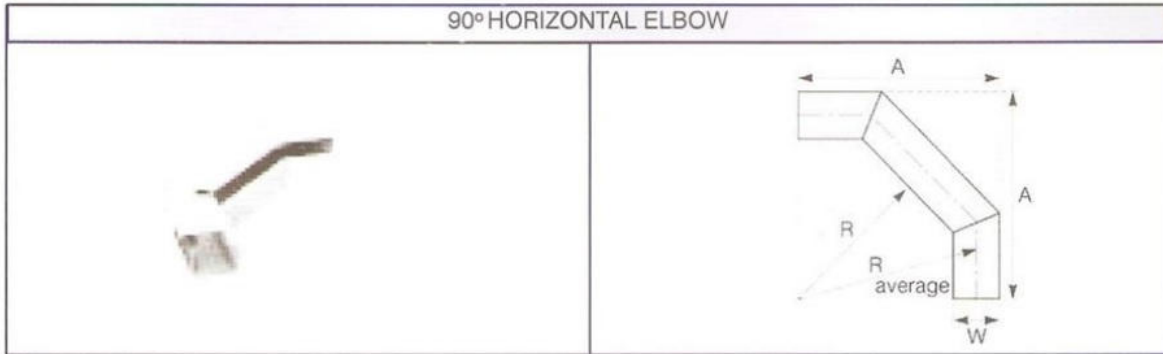

### Cable Tray

| HEIGHT (mm) | WIDTH (mm) | CATALOG NO.         | RADIUS | A   |
|-------------|------------|---------------------|--------|-----|
| 50          | 50         | SO-AIS-100-90HE-300 | 300    | 508 |
|             | 100        | SO-AIS-150-90HE-300 |        | 558 |
|             | 150        | SO-AIS-200-90HE-300 |        | 620 |
|             | 200        | SO-AIS-300-90HE-300 |        | 708 |
| 75          | 50         | SO-AIS-100-90HE-300 | 300    | 508 |
|             | 100        | SO-AIS-150-90HE-300 |        | 558 |
|             | 150        | SO-AIS-200-90HE-300 |        | 620 |
|             | 200        | SO-AIS-300-90HE-300 |        | 708 |

NOTE: - Substitute "P" in place of "S" for punched

| HEIGHT (mm) | WIDTH (mm) | CATALOG NO.         | RADIUS | A   |
|-------------|------------|---------------------|--------|-----|
| 50          | 50         | SO-AIS-100-90HE-600 | 600    | 508 |
|             | 100        | SO-AIS-150-90HE-600 |        | 558 |
|             | 150        | SO-AIS-200-90HE-600 |        | 620 |
|             | 200        | SO-AIS-300-90HE-600 |        | 708 |
| 75          | 50         | SO-AIS-100-90HE-600 | 600    | 508 |
|             | 100        | SO-AIS-150-90HE-600 |        | 558 |
|             | 150        | SO-AIS-200-90HE-600 |        | 620 |
|             | 200        | SO-AIS-300-90HE-600 |        | 708 |

NOTE: - Substitute "P" in place of "S" for punched channel.

### Cover

| HEIGHT (mm) | WIDTH (mm) | CATALOG NO.         | RADIUS | A   |
|-------------|------------|---------------------|--------|-----|
| 50          | 50         | SO-AIS-100-90HE-300 | 300    | 508 |
|             | 100        | SO-AIS-150-90HE-300 |        | 558 |
|             | 150        | SO-AIS-200-90HE-300 |        | 620 |
|             | 200        | SO-AIS-300-90HE-300 |        | 708 |
| 75          | 50         | SO-AIS-100-90HE-300 | 300    | 508 |
|             | 100        | SO-AIS-150-90HE-300 |        | 558 |
|             | 150        | SO-AIS-200-90HE-300 |        | 620 |
|             | 200        | SO-AIS-300-90HE-300 |        | 708 |

| HEIGHT (mm) | WIDTH (mm) | CATALOG NO.         | RADIUS | A   |
|-------------|------------|---------------------|--------|-----|
| 50          | 50         | SO-AIS-100-90HE-600 | 600    | 508 |
|             | 100        | SO-AIS-150-90HE-600 |        | 558 |
|             | 150        | SO-AIS-200-90HE-600 |        | 620 |
|             | 200        | SO-AIS-300-90HE-600 |        | 708 |
| 75          | 50         | SO-AIS-100-90HE-600 | 600    | 508 |
|             | 100        | SO-AIS-150-90HE-600 |        | 558 |
|             | 150        | SO-AIS-200-90HE-600 |        | 620 |
|             | 200        | SO-AIS-300-90HE-600 |        | 708 |

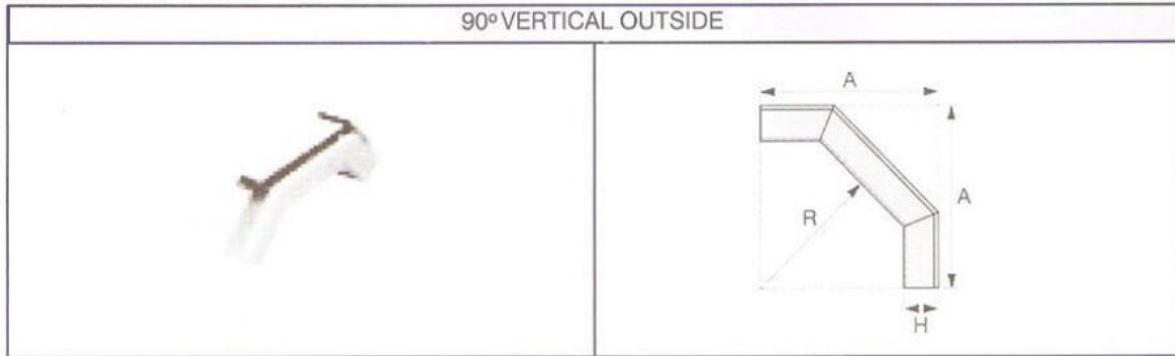

## Cable Tray

| HEIGHT (mm) | WIDTH (mm) | CATALOG NO.         | RADIUS | A   |
|-------------|------------|---------------------|--------|-----|
| 50          | 50         | SO-AIS-100-90VO-300 | 300    | 508 |
|             | 100        | SO-AIS-150-90VO-300 |        | 558 |
|             | 150        | SO-AIS-200-90VO-300 |        | 620 |
|             | 200        | SO-AIS-300-90VO-300 |        | 708 |
| 75          | 50         | SO-AIS-100-90VO-300 | 300    | 508 |
|             | 100        | SO-AIS-150-90VO-300 |        | 558 |
|             | 150        | SO-AIS-200-90VO-300 |        | 620 |
|             | 200        | SO-AIS-300-90VO-300 |        | 708 |

NOTE: - Substitute "P" in place of "S" for punched channel.

| HEIGHT (mm) | WIDTH (mm) | CATALOG NO.         | RADIUS | A    |
|-------------|------------|---------------------|--------|------|
| 50          | 50         | SO-AIS-100-90VO-600 | 600    | 808  |
|             | 100        | SO-AIS-150-90VO-600 |        | 858  |
|             | 150        | SO-AIS-200-90VO-600 |        | 920  |
|             | 200        | SO-AIS-300-90VO-600 |        | 1008 |
| 75          | 50         | SO-AIS-100-90VO-600 | 600    | 808  |
|             | 100        | SO-AIS-150-90VO-600 |        | 858  |
|             | 150        | SO-AIS-200-90VO-600 |        | 920  |
|             | 200        | SO-AIS-300-90VO-600 |        | 1008 |

NOTE: - Substitute "P" in place of "S" for punched channel.

## Cover

| HEIGHT (mm) | WIDTH (mm) | CATALOG NO.         | RADIUS | A   |
|-------------|------------|---------------------|--------|-----|
| 50          | 50         | SO-AIC-100-90VO-300 | 300    | 508 |
|             | 100        | SO-AIC-150-90VO-300 |        | 558 |
|             | 150        | SO-AIC-200-90VO-300 |        | 620 |
|             | 200        | SO-AIC-300-90VO-300 |        | 708 |
| 75          | 50         | SO-AIC-100-90VO-300 | 300    | 508 |
|             | 100        | SO-AIC-150-90VO-300 |        | 558 |
|             | 150        | SO-AIC-200-90VO-300 |        | 620 |
|             | 200        | SO-AIC-300-90VO-300 |        | 708 |

| HEIGHT (mm) | WIDTH (mm) | CATALOG NO.         | RADIUS | A    |
|-------------|------------|---------------------|--------|------|
| 50          | 50         | SO-AIC-100-90VO-600 | 600    | 808  |
|             | 100        | SO-AIC-150-90VO-600 |        | 858  |
|             | 150        | SO-AIC-200-90VO-600 |        | 920  |
|             | 200        | SO-AIC-300-90VO-600 |        | 1008 |
| 75          | 50         | SO-AIC-100-90VO-600 | 600    | 808  |
|             | 100        | SO-AIC-150-90VO-600 |        | 858  |
|             | 150        | SO-AIC-200-90VO-600 |        | 920  |
|             | 200        | SO-AIC-300-90VO-600 |        | 1008 |



# AB-Cope Wire Basket

9

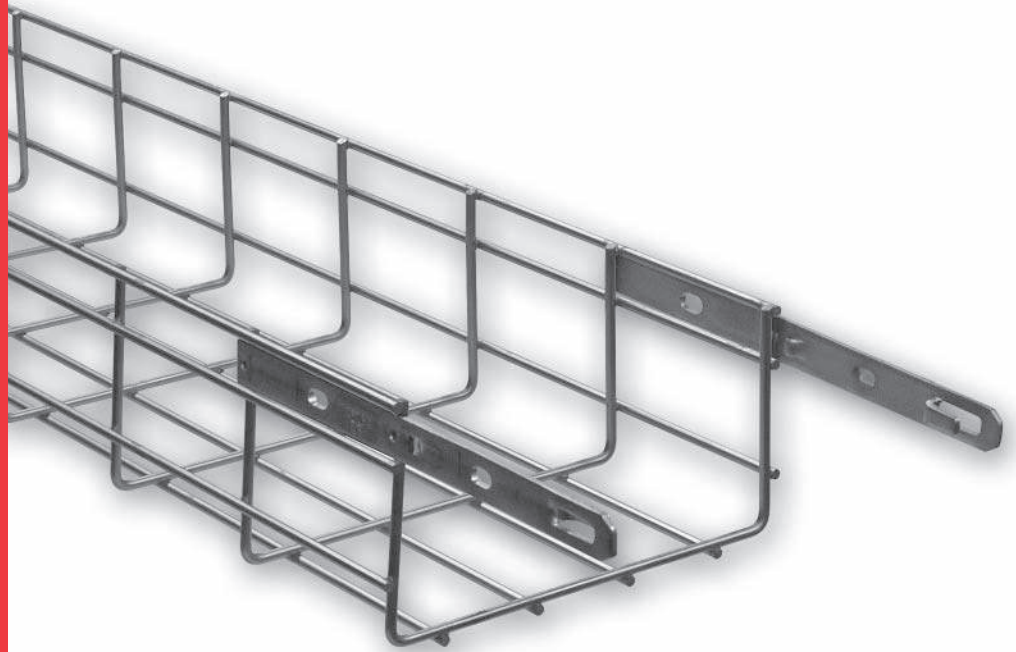

# WIRE BASKET SYSTEM

## General & Technical Information

|                |     |
|----------------|-----|
| Overview ..... | 237 |
| Assembly ..... | 238 |

|                                |           |
|--------------------------------|-----------|
| Straight Length                |           |
| 2" Load Depth .....            | 239       |
| 4" Load Depth .....            | 240       |
| 6" Load Depth .....            | 241       |
| Bar Connectors .....           | 242       |
| Connection Hardware Kits ..... | 243 - 244 |
| Support Brackets .....         | 245       |
| Drop Rod Clips .....           | 256       |
| Wall & Ceiling Mounts .....    | 247       |
| Zed Bracket .....              | 248       |
| Cantilevers .....              | 248       |
| Hangers .....                  | 249       |
| Pendants .....                 | 250       |
| Hanging Brackets .....         | 250 - 252 |
| Pedestal Brackets .....        | 253       |

## Covers

|              |     |
|--------------|-----|
| Covers ..... | 254 |
|--------------|-----|

## Accessories

|                     |     |
|---------------------|-----|
| Drop Outs .....     | 254 |
| Tray Dividers ..... | 254 |
| Blind Ends .....    | 255 |
| Box Connector ..... | 255 |
| Brackets .....      | 256 |
| Wall Sleeve .....   | 256 |
| Cutting Tool .....  | 257 |

|                              |           |
|------------------------------|-----------|
| 90° Long Radius Bends .....  | 258       |
| 90° Short Radius Bends ..... | 259 - 260 |
| Standard Tee .....           | 261       |
| Cross .....                  | 261       |
| Reducer .....                | 262       |
| Offset .....                 | 262       |
| .....                        | 262       |

|                                 |           |
|---------------------------------|-----------|
| Grounding Clips and Clamp ..... | 263       |
| .....                           | 264 - 266 |

|  |     |
|--|-----|
| Electrical Grounding Information ..... | 263 |
| Sample Specification .....             | 267 |

## Straight Length

Pages 238 - 240

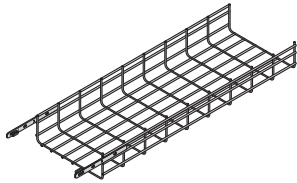

## Bar Connectors & Hardware

Pages 241 - 243

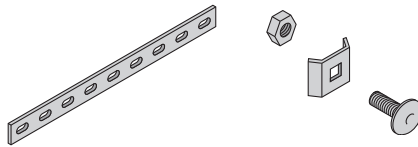

## Support Brackets

Page 244

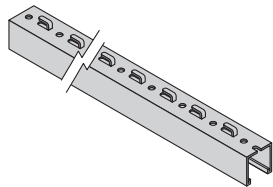

## Drop Rod Clips

Page 245

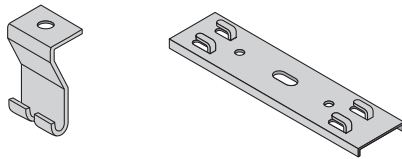

## Wall & Ceiling Mounts

Page 246

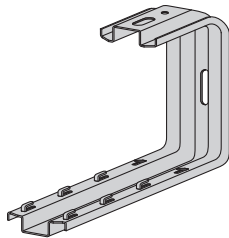

## Cantilever & Zed Brackets

Page 247

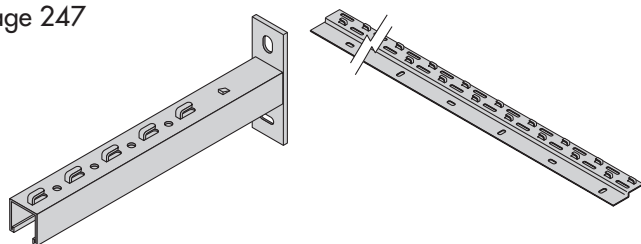

## Hangers & Hanging Brackets

Pages 248 - 251

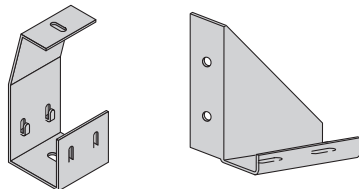

## Pendants

Page 249

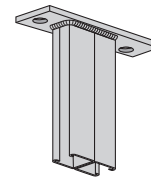

## Pedestal Brackets

Page 252

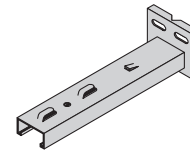

## Covers

Page 253

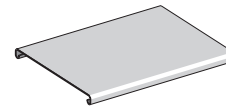

## Tray Dividers and Drop Outs

Page 253

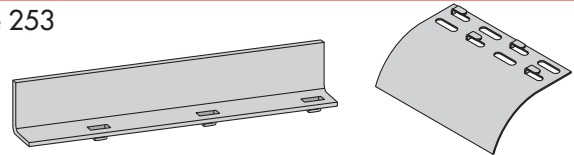

## Accessories

Pages 254 - 255

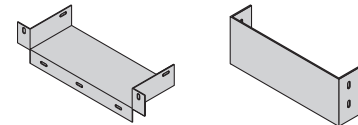

## Long & Short Radius Bends

Pages 257 - 259

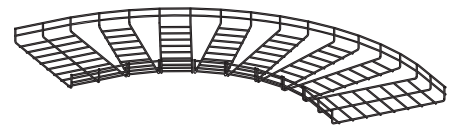

## Cross & Tee Fittings

Page 260

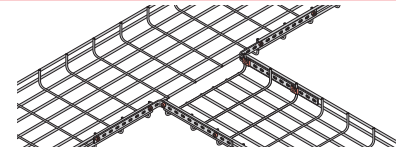

## Riser, Reducer & Offset Fittings

Page 261

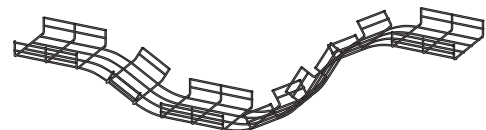

## Grounding & Hardware

Pages 262 - 265

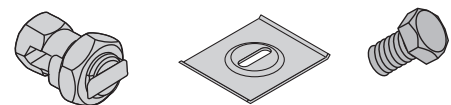

## OVERVIEW

### Product Description

Wire basket tray is a welded wire mesh cable management system produced from high strength steel wires. Wire basket tray is produced by first welding a net, forming the channel, and then finishing after fabrication. The 2" x 4" mesh permits continuous airflow to help prevent heat buildup. In addition, this unique open design prevents the buildup of dust, contaminants and bacterial proliferation.

Wire basket tray is produced in standard 10' lengths and is supplied in three channel depths: 2", 4", and 6".

Wire basket tray is offered in nine different widths:

|              |                  |
|--------------|------------------|
| 2" (50 mm),  | 4" (100mm),      |
| 6" (150mm),  | 8" (200mm),      |
| 12" (300mm), | 16" (400mm),     |
| 18" (450mm), | 20" (500mm), and |
| 24" (550mm). |                  |

Special sizes are available to meet your unique requirements.

**CAT2 Series – 2" HIGH,  
2" TO 24" WIDE**

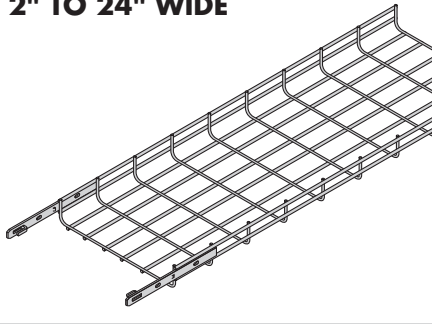

**CAT4 Series – 4" HIGH,  
4" TO 24" WIDE**

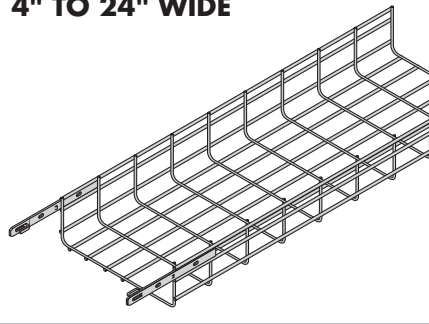

**CAT6 Series – 6" HIGH,  
12", 16" & 24" WIDE**

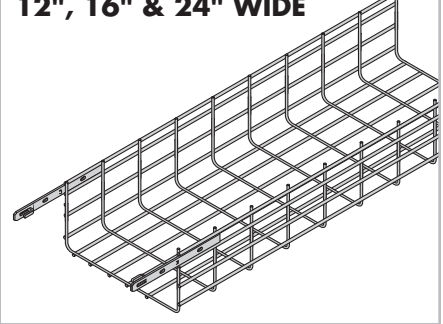

### Standard Finish

**EG — ELECTRO-PLATED ZINC GALVANIZED** – (ASTM B633 TYPE III, SC3 • Thickness: .000472" (12µm))

Electrodeposited zinc coating is suitable for most indoor applications and may be used outdoors in mild environmental conditions.

### Special Order Finishes

**HG — HOT DIP GALVANIZED** – (ASTM A123 GRD.55 • Thickness: .0002165" (55µm))

Provided by immersing the product in a molten zinc bath. This treatment is most suitable for outdoor applications or situations where increased corrosion resistance is desired.

**SS — 304 TYPE STAINLESS STEEL or  
S1 — 316 TYPE STAINLESS STEEL**

Corrosive resistant stainless steel with no additional surface treatment. This material option provides the best corrosion resistance available. Stainless steel is used primarily in marine environments or food processing facilities.

**ZD — DICHROMATE** – (ASTM B633 Type II, SC3 • Thickness: .000472" (12µm))

An electro-galvanized zinc plate is applied to the steel base metal. Yellow dichromate is applied over the zinc and results in a gold appearance which acts as a nonporous barrier sealant.

**Other** – Powder coating available.

### How To Order

Part numbers shown in the catalog are for the standard electro-galvanized finish. For special order finishes, add the finish code as a suffix.

### EXAMPLE –

CAT2-12SL-120 is electro-galvanized  
CAT2-12SL-120-SS is stainless steel

## Self-Splicing Straight Lengths

The Kwik-Latch splicing system makes connecting wire basket tray fast and simple. The Kwik-Latch, or self splicing bars which come pre-installed on wire basket tray systems, eliminates the need for a typical nut and bolt type connection. For proper grounding of wire basket tray please refer to page 262.

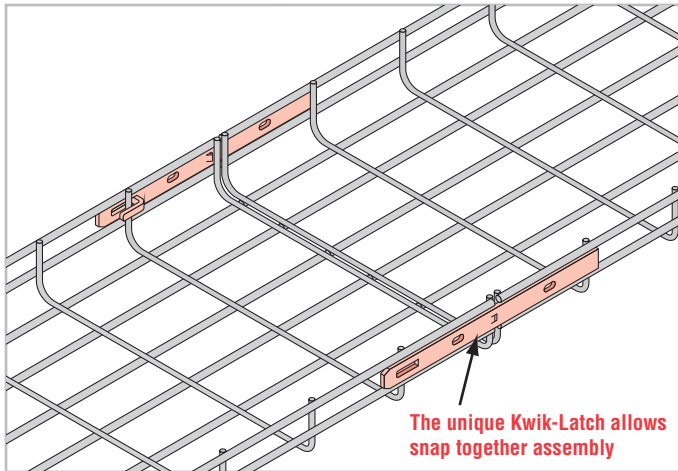

## Wire Basket Assembly - CAT2, CAT4, & CAT6

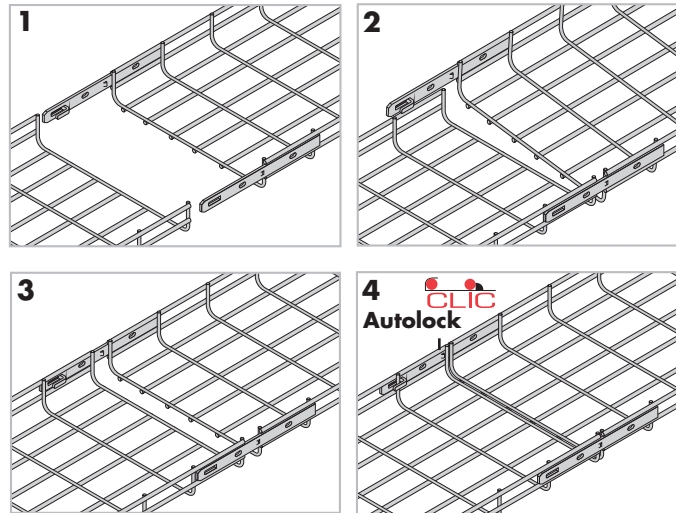

- Step 1** Align the trays as shown.
- Step 2** While raising the rear edge of the male connection, slide the tray forward, but do not engage the locking clip.
- Step 3** Push the rear locking clip over the back edge of the tray.
- Step 4** Slide the tray forward to engage both front and rear locking clips.

## Accessory Assembly

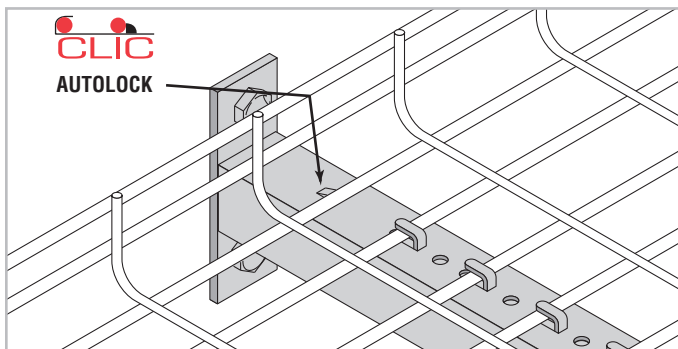

Many of the wire basket accessories feature the unique Autolock. Just slide the tray under the tabs and then push down to engage the Autolock. No tools, bending, or attachments are required for a secure connection.

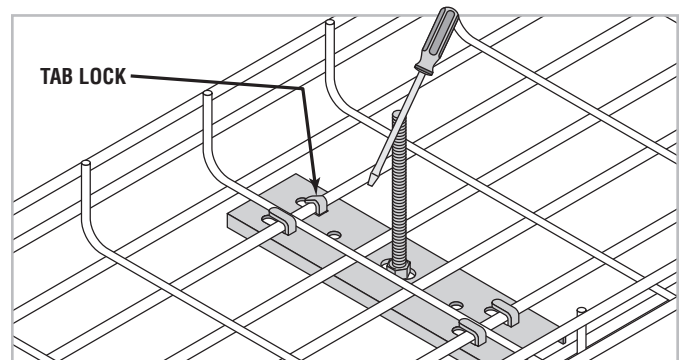
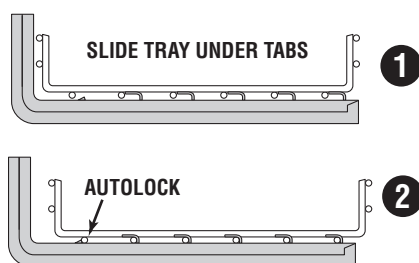

For accessories which use the tab lock, the tray is secured by using a screw driver to gently bend one of the tabs down over the tray.

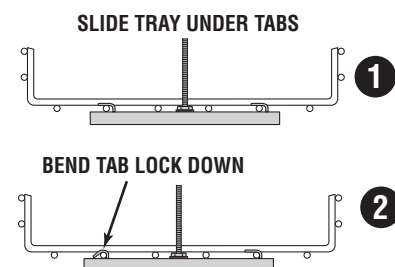

# WIRE BASKET SYSTEM

## DOUBLE ROD REINFORCED TRAY (2" DEPTH)

### Double Rod Reinforced Tray (2" Depth) [CAT2-(W)SL-120]

- Double rod reinforced tray is 2" high
- Standard length of tray is 10'
- Standard finish is electro-galvanized (EG)
- No hardware is necessary to connect straight sections
- For continuous grounding use CAT-GC (See page 252.)

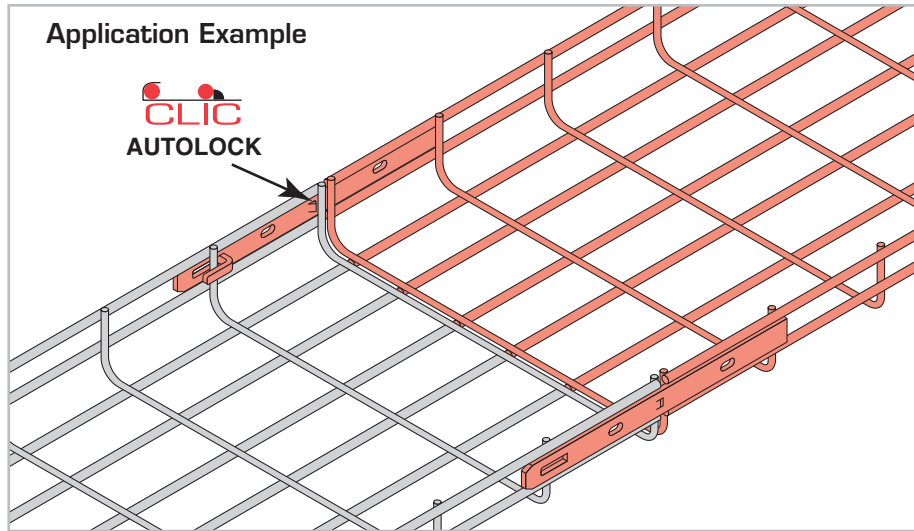
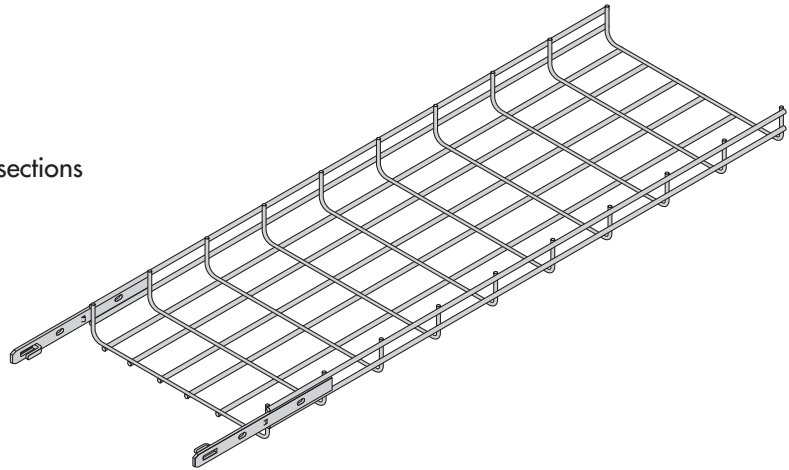

| Approvals        |                  | Part Description | Width Nominal | Dimensions Wire Dia (in.) | Wt. (piece) | Loading (lb/ft) |         |         |         |    |
|------------------|------------------|------------------|---------------|---------------------------|-------------|-----------------|---------|---------|---------|----|
| UL               | cUL              |                  |               |                           |             | 5' Span         | 6' Span | 8' Span | 9' Span |    |
|                  | CLASSIFIED<br>UL |                  | CAT2-02SL-120 | 2" (50mm)                 | 0.177       | 4.6             | 60      | 42      | 23      | 19 |
|                  | CLASSIFIED<br>UL |                  | CAT2-04SL-120 | 4" (100mm)                | 0.177       | 6.8             | 60      | 42      | 23      | 19 |
|                  | CLASSIFIED<br>UL |                  | CAT2-06SL-120 | 6" (150mm)                | 0.177       | 8.0             | 60      | 42      | 23      | 19 |
| CLASSIFIED<br>UL | CLASSIFIED<br>UL |                  | CAT2-08SL-120 | 8" (200mm)                | 0.197       | 9.3             | 89      | 62      | 35      | 27 |
| CLASSIFIED<br>UL | CLASSIFIED<br>UL |                  | CAT2-12SL-120 | 12" (300mm)               | 0.197       | 14.5            | 89      | 62      | 35      | 27 |
| CLASSIFIED<br>UL | CLASSIFIED<br>UL |                  | CAT2-16SL-120 | 16" (400mm)               | 0.236       | 25.3            | 149     | 103     | 58      | 46 |
| CLASSIFIED<br>UL | CLASSIFIED<br>UL |                  | CAT2-18SL-120 | 18" (450mm)               | 0.236       | 27.6            | 149     | 103     | 58      | 46 |
| CLASSIFIED<br>UL | CLASSIFIED<br>UL |                  | CAT2-20SL-120 | 20" (500mm)               | 0.236       | 29.8            | 149     | 103     | 58      | 46 |
| CLASSIFIED<br>UL | CLASSIFIED<br>UL |                  | CAT2-24SL-120 | 24" (600mm)               | 0.236       | 34.3            | 149     | 103     | 58      | 46 |









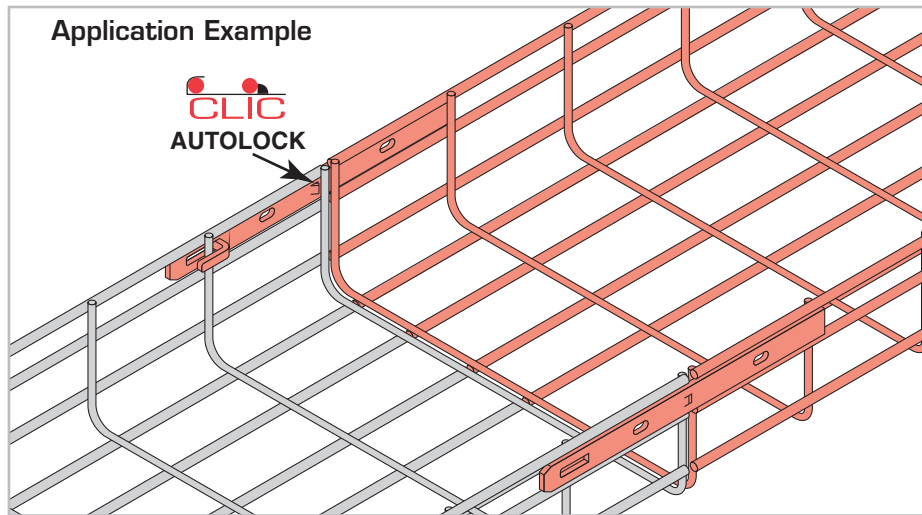
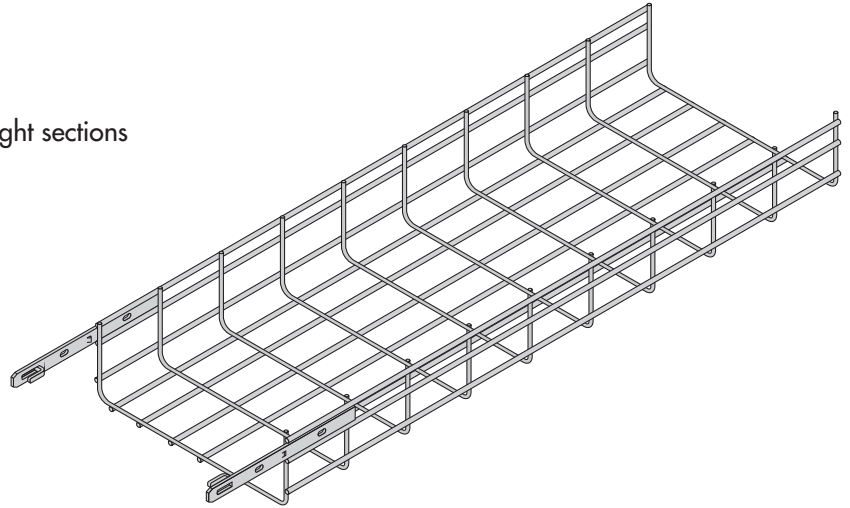











Load Values are determined by NEMA VE1 testing. Copies of load tests available upon request.  
Safety Factor 1.5

**Denotes Popular Sizes**

### Triple Rod Reinforced Tray (4" Depth) [CAT4-(W)SL-120]

- Triple rod reinforced tray is 4" high
- Standard length of tray is 10'
- Standard finish is electro-galvanized (EG)
- No hardware is necessary to connect straight sections
- For continuous grounding use CAT-GC (See page 262.)



| Approvals   |   | Part Description  | Width Nominal | Dimensions Wire Dia (in.) | Wt. (piece) | Loading (lb/ft) |         |         |         |
|---|---|---|---------------|---------------------------|-------------|-----------------|---------|---------|---------|
| UL  | cUL   |   |               |                           |             | 5' Span         | 6' Span | 8' Span | 9' Span |
|  |  |  CAT4-04SL-120 | 4" (100mm)    | 0.197                     | 9.3         | 108             | 75      | 42      | 33      |
|  |  |  CAT4-08SL-120 | 8" (200mm)    | 0.197                     | 14.5        | 108             | 75      | 42      | 33      |
|  |  |  CAT4-12SL-120 | 12" (300mm)   | 0.236                     | 25.3        | 182             | 127     | 71      | 56      |
|  |  |  CAT4-16SL-120 | 16" (400mm)   | 0.236                     | 29.8        | 182             | 127     | 71      | 56      |
|  |  |  CAT4-18SL-120 | 18" (450mm)   | 0.236                     | 32.0        | 182             | 127     | 71      | 56      |
|  |  |  CAT4-20SL-120 | 20" (500mm)   | 0.236                     | 34.3        | 182             | 127     | 71      | 56      |
|  |  |  CAT4-24SL-120 | 24" (600mm)   | 0.236                     | 38.8        | 182             | 127     | 71      | 56      |

Load Values are determined by NEMA VE1 testing. Copies of load tests available upon request.  
Safety Factor 1.5

Denotes Popular Sizes

# WIRE BASKET SYSTEM

## QUADRUPLE ROD REINFORCED TRAY (6" DEPTH)

### Quadruple Rod Reinforced Tray (6" Depth) [CAT6-(W)SL-120]

- Quadruple rod reinforced tray is 6" high
- Standard length of tray is 10'
- Standard finish is electro-galvanized (EG)
- No hardware is necessary to connect straight sections
- For continuous grounding use CAT-GC (See page 262.)

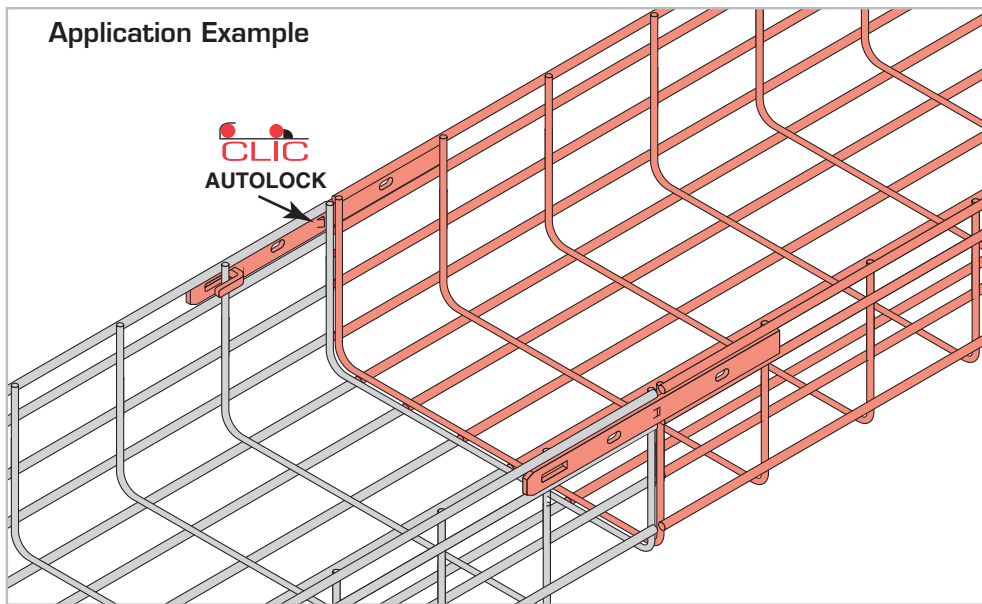
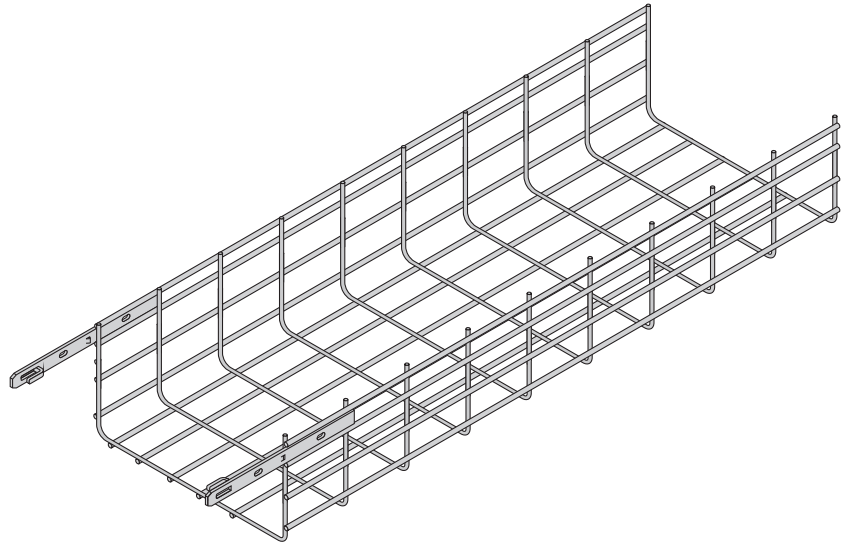

| Part Description |               | Width Nominal | Dimensions Wire Dia (in.) | Wt. (piece) | Loading (lb/ft) |         |         |         |
|------------------|---------------|---------------|---------------------------|-------------|-----------------|---------|---------|---------|
|                  |               |               |                           |             | 5' Span         | 6' Span | 8' Span | 9' Span |
|                  | CAT6-08SL-120 | 8" (200mm)    | 0.236                     | 25.3        | 235             | 163     | 92      | 73      |
|                  | CAT6-12SL-120 | 12" (300mm)   | 0.236                     | 29.8        | 235             | 163     | 92      | 73      |
|                  | CAT6-16SL-120 | 16" (400mm)   | 0.236                     | 34.3        | 235             | 163     | 92      | 73      |
|                  | CAT6-18SL-120 | 18" (450mm)   | 0.236                     | 36.4        | 235             | 163     | 92      | 73      |
|                  | CAT6-20SL-120 | 20" (500mm)   | 0.236                     | 38.8        | 235             | 163     | 92      | 73      |
|                  | CAT6-24SL-120 | 24" (600mm)   | 0.236                     | 48.4        | 235             | 163     | 92      | 73      |

Load Values are determined by NEMA VE1 testing. Copies of load tests available upon request.  
Safety Factor 1.5

### Splice

Weight: .29/each

- Splice bar connector is  $\frac{3}{4}$  x 9" long
- Standard finish is electro-galvanized (EG)
- Connect using CH3 (sold separately)
- Bend  $90^\circ$  for use as an angle connector

NOTES:

1. Always place nut on outside of tray
2. For use with CAT2, CAT4, & CAT6 tray
3. The splice connector is used to connect remnant sections of tray cut from standard lengths and to field fabricate fittings.

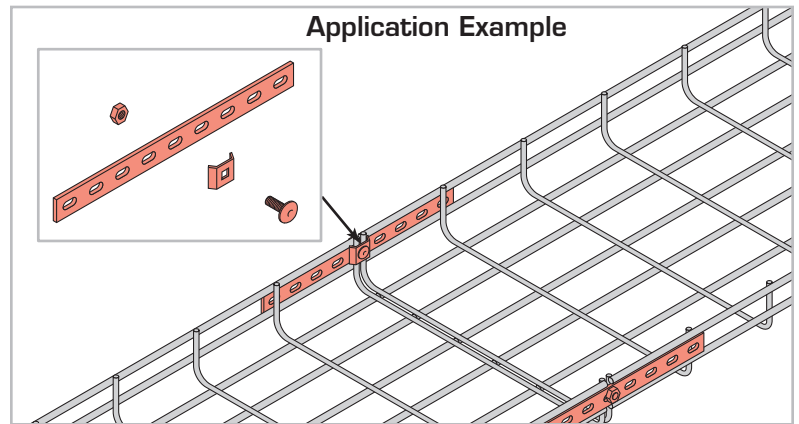
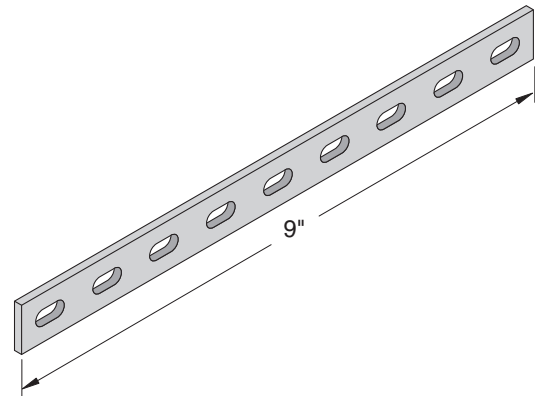

### Bend & Intersection Bars

#### T-BAR

Weight: 1.43/each

- T-Bar connector is  $\frac{3}{4}$  x 44" long
- Connect using CH3 (sold separately)
- Bend  $90^\circ$  for use as an angle connector

#### T-BAR-22

Weight: .715/each

- T-Bar connector is  $\frac{3}{4}$  x 22" long
- Connect using CH3 (sold separately)

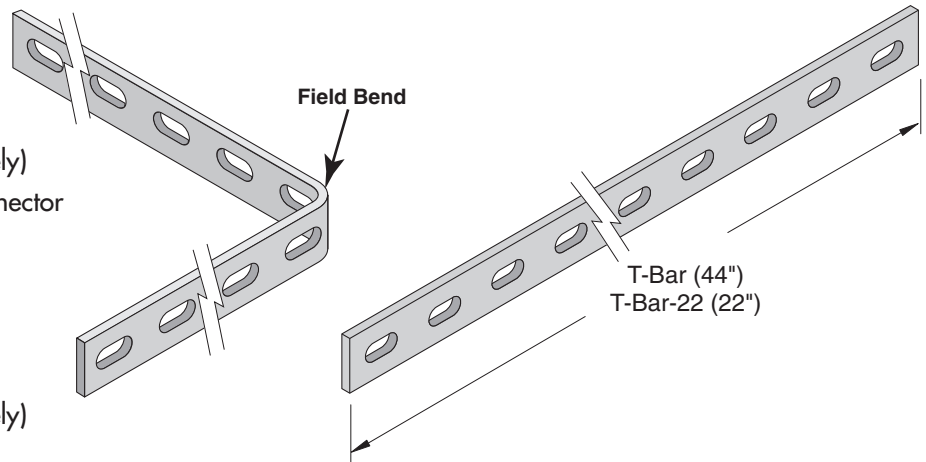

NOTES:

1. Always place nut on outside of tray
2. For use with CAT2, CAT4, & CAT6 tray
3. Used for tees which require a heavier support
4. These bars are normally cut to appropriate length

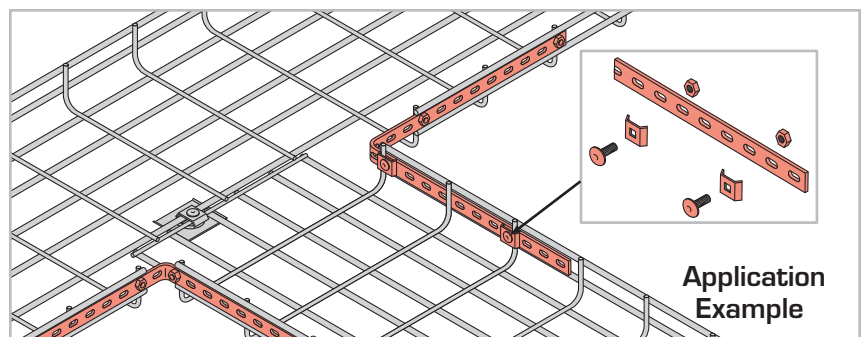

Application Example

## CONNECTOR HARDWARE

### Connector Hardware Overview

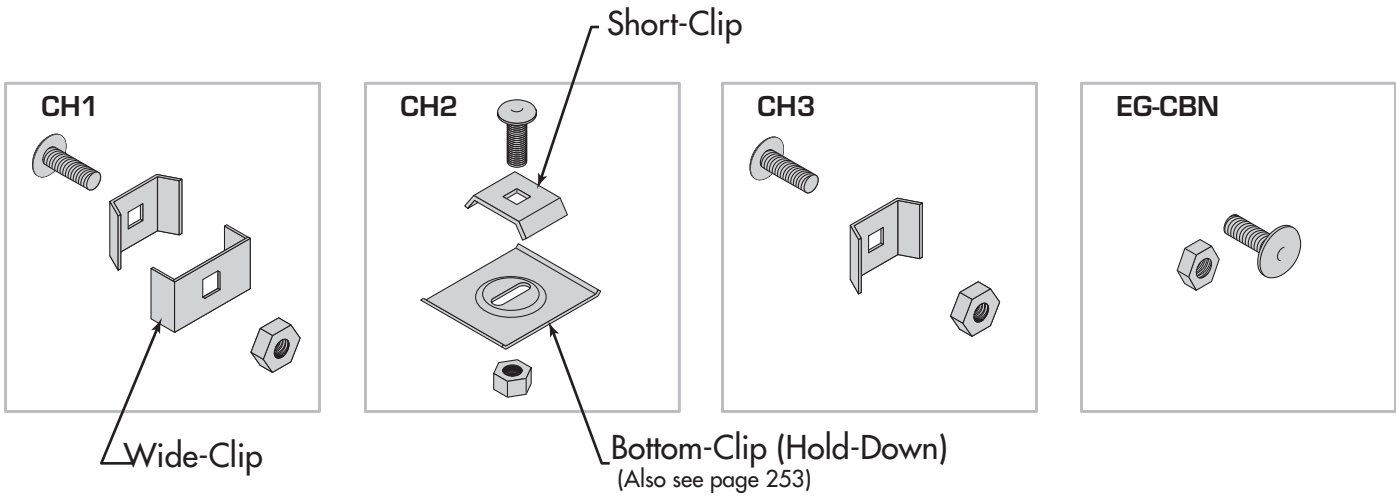

| Part Kit | WEIGHT | NO./ PKG |
|----------|--------|----------|
| CH1      | 0.70   | 10       |
| CH2      | 1.16   | 10       |
| CH3      | 0.44   | 10       |
| EG-CBN   | 0.20   | 10       |

| Single Part | WEIGHT | NO./ PKG |
|-------------|--------|----------|
| Short-Clip  | 0.20   | 10       |
| Wide-Clip   | 0.31   | 10       |
| Bottom-Clip | 0.92   | 10       |

### Connector Kit [CH1]

- Standard bar connector is 1<sup>3</sup>/<sub>16</sub> x 1<sup>1</sup>/<sub>16</sub>"
- Standard finish is electro-galvanized (EG)
- Sold in packs of 10 (EG-CBN connector hardware included)

NOTE: Always place nut on outside of tray

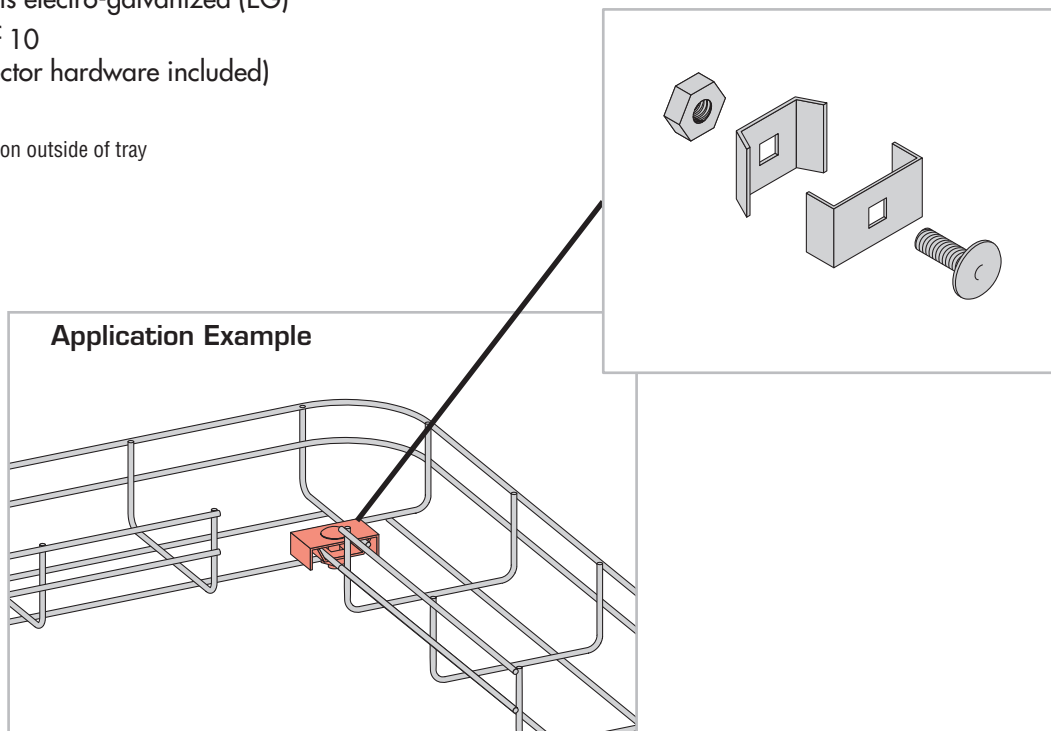

### Connector Kit [CH2]

- Bottom connector is 2 x 2<sup>3</sup>/<sub>8</sub>"
- Standard finish is electro-galvanized (EG)
- Sold in packs of 10  
(EG-CBN connector hardware included)

NOTE: Always place nut on outside of tray

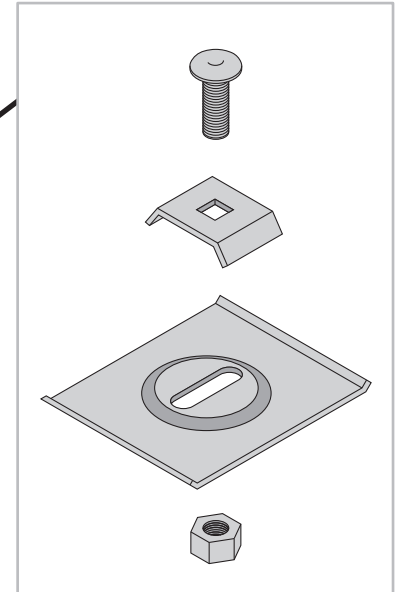
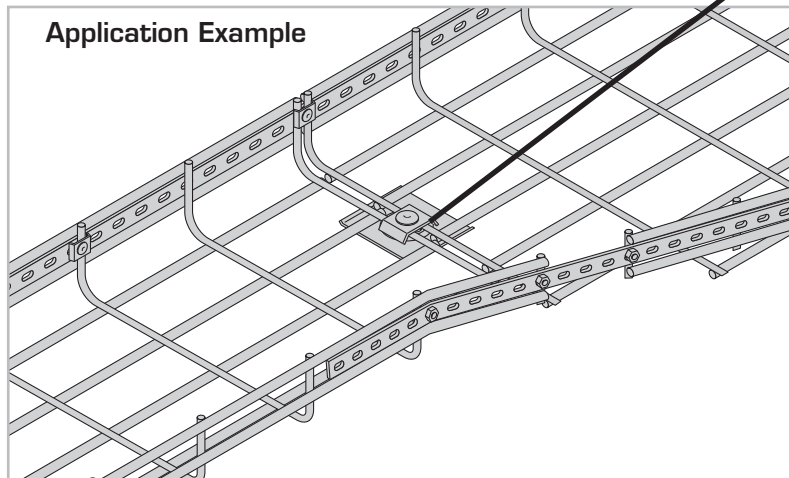

### Connector Kit [CH3]

- Universal connector is 1<sup>1</sup>/<sub>16</sub> x 1<sup>5</sup>/<sub>16</sub>"
- Standard finish is electro-galvanized (EG)
- Sold in packs of 10  
(EG-CBN connector hardware included)

NOTE: Always place nut on outside of tray

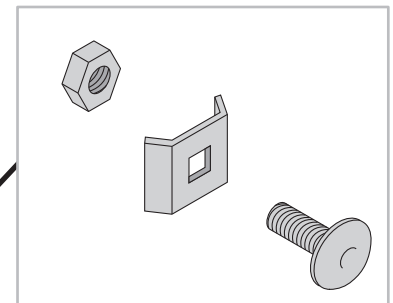
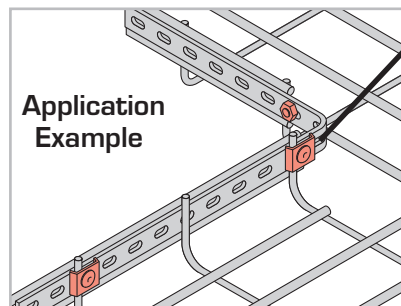

### Connector Hardware [EG-CBN]

- 1/4-20 x 3/4" Carriage bolt
- 1/4-20 Hex head nut
- Standard finish is electro-galvanized (EG)
- Sold in packs of 10 each

NOTE: Always place nut on outside of tray

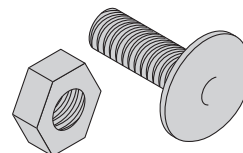

## U Support Bracket [CAT-USB-120]

Weight: 6.83 lb/each

- U support bracket  $1\frac{5}{16} \times 1\frac{5}{16}$ " channel
- Standard finish is pregalvanized (PG)
- Support is 10' long, customer cuts to size as needed
- Cut lengths 6" wider than tray width for trapeze  
Cut lengths 1" shorter than tray width for single rod support
- Unique grip system requires only a push of a screwdriver to fasten the tray to the supports

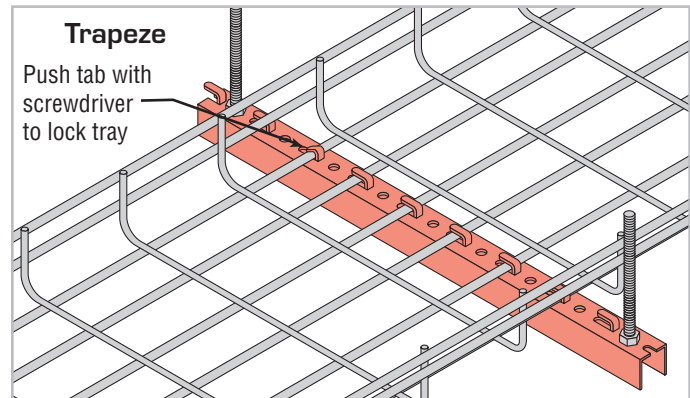
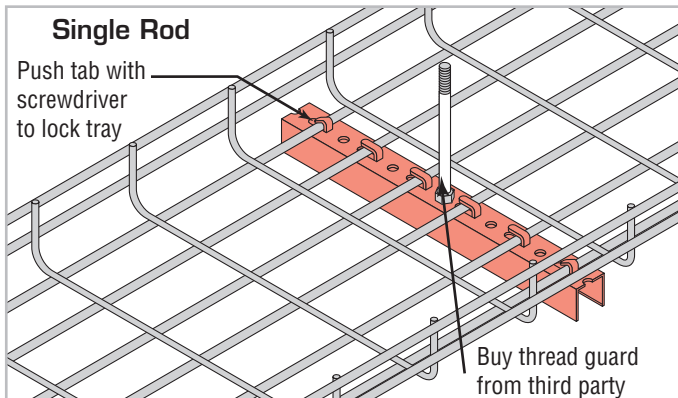
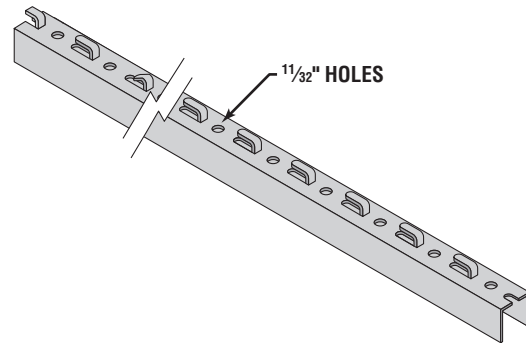

## Support Bracket Medium [CAT-MSB-120] & Heavy [CAT-HSB-120]

- Heavy support bracket is  $1\frac{5}{8} \times 1\frac{5}{8}$ " strut, Medium support bracket is  $1\frac{5}{8} \times 1\frac{3}{16}$ " strut
- Standard finish is pregalvanized (PG)
- Support is 10' long, customer cuts to size as needed
- Cut lengths 6" wider than tray width for trapeze  
Cut lengths 1" shorter than tray width for single rod support
- Unique grip system requires only a push of a screwdriver to fasten the tray to the supports

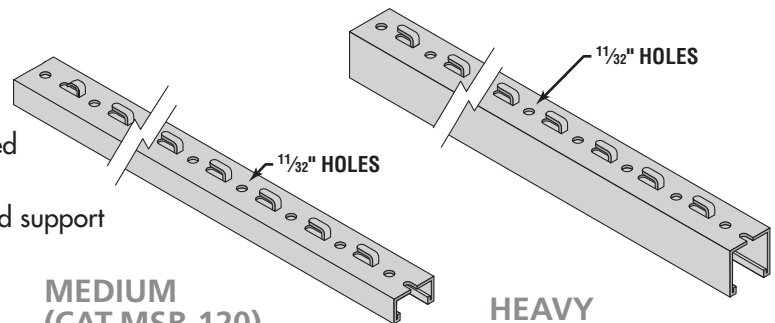

**MEDIUM (CAT-MSB-120)**

Weight 11.9 lb/each

**HEAVY (CAT-HSB-120)**

Weight: 16.53 lb/each

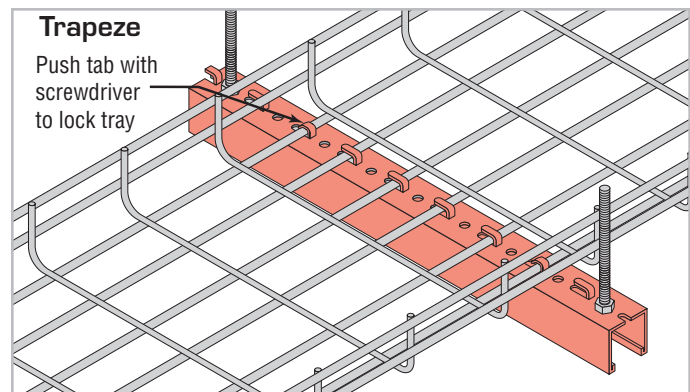
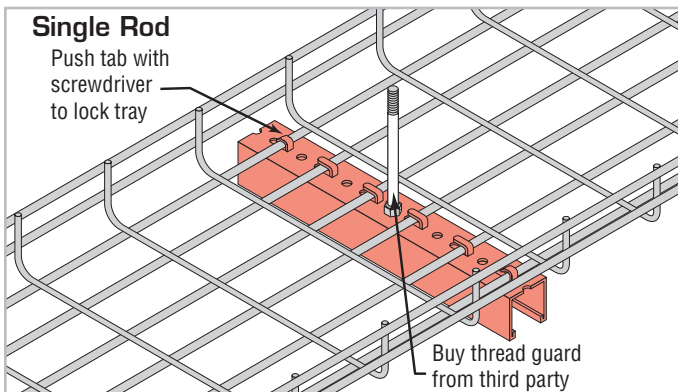

### Drop Rod Clip [CAT-SIDE-HC]

Weight: .13 lb/each

- Standard finish pregalvanized (PG)
- .08" Bracket thickness
- For all widths of tray

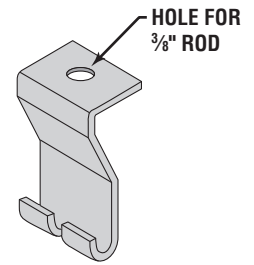
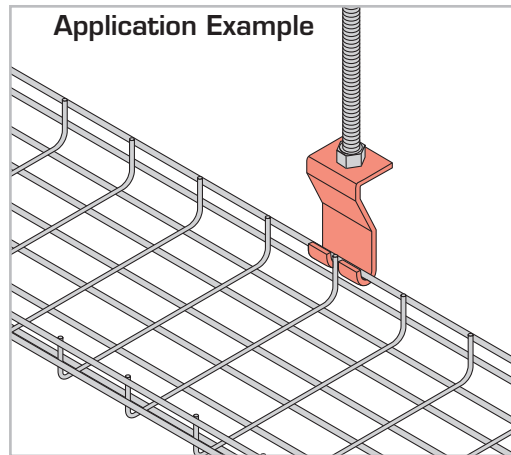

### Drop Rod Clip [CAT-1x6-HC]

Weight: .12 lb/each

- Standard finish pregalvanized (PG)
- .08" Bracket thickness
- For all 4"w & 6"w tray

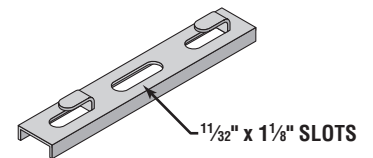
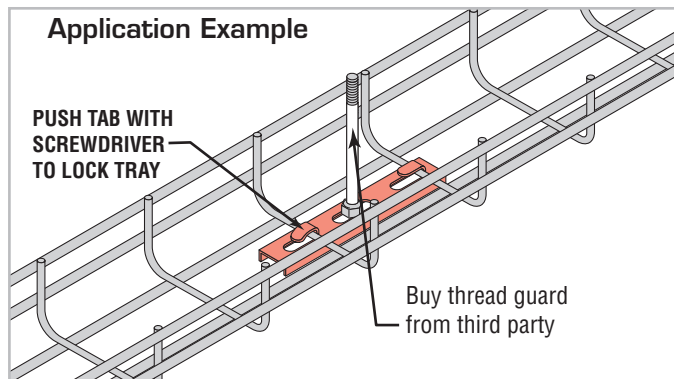

### Drop Rod Clip [CAT-2x8-HC]

Weight: .40 lb/each

- Standard finish pregalvanized (PG)
- .08" Bracket thickness
- For all 8" w & 12" w tray

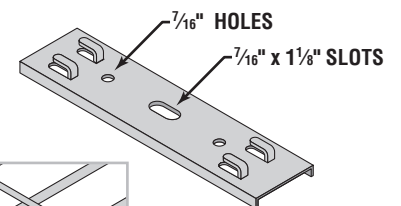
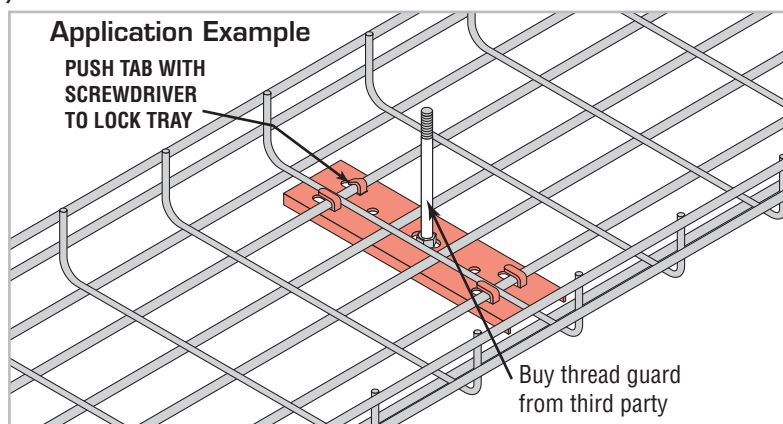

## WALL & CEILING MOUNTS

### Ceiling Clip [CAT-CCA-(W)]

- For attaching tray to ceiling
- Standard finish pregalvanized (PG)
- Easy mounting of the cable tray using grips and autolock

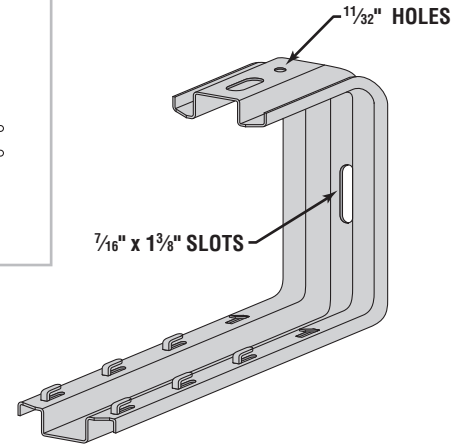
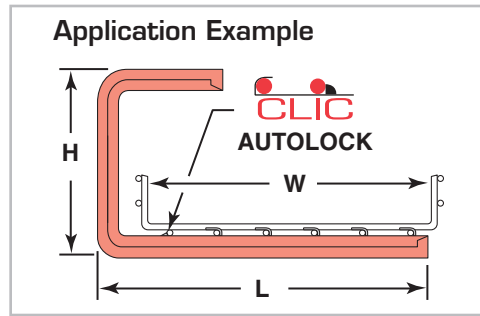

| Part No.   | Tray Size (W) | Height (H) | Length (L) | Wt (Lbs) | Load (Lbs) |
|------------|---------------|------------|------------|----------|------------|
| CAT-CCA-04 | 4"            | 7"         | 6"         | 1.3      | 270        |
| CAT-CCA-06 | 6"            | 7"         | 8"         | 1.5      | 225        |
| CAT-CCA-08 | 8"            | 7"         | 10"        | 1.7      | 202        |
| CAT-CCA-12 | 12"           | 7"         | 14"        | 2.0      | 180        |
| CAT-CCA-16 | 16"           | 7"         | 18"        | 2.3      | 90         |

### Wall Clip [CAT-CPA-(W)]

- For attaching tray to wall
- Standard finish pregalvanized (PG)
- Easy mounting of the cable tray using grips and autolock

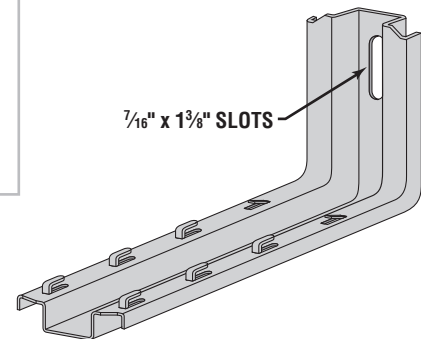
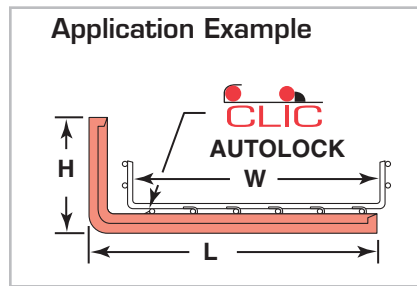

| Part No.   | Tray Size (W) | Height (H) | Length (L) | Wt (Lbs) | Load (Lbs) |
|------------|---------------|------------|------------|----------|------------|
| CAT-CPA-06 | 6"            | 5"         | 8"         | 1.0      | 337        |
| CAT-CPA-08 | 8"            | 5"         | 10"        | 1.1      | 225        |
| CAT-CPA-12 | 12"           | 5"         | 14"        | 1.5      | 202        |
| CAT-CPA-16 | 16"           | 5"         | 18"        | 1.8      | 90         |

### Pendant [CAT-PPA-(H)]

- Standard finish is pregalvanized (PG)
- For attaching tray to ceiling. Used with wall clip CAT-CPA Series

| Part No.   | Height (H) | Length (L) | Wt (Lbs) |
|------------|------------|------------|----------|
| CAT-PPA-06 | 6"         | 5"         | 0.7      |
| CAT-PPA-10 | 10"        | 5"         | 1.1      |
| CAT-PPA-14 | 14"        | 5"         | 1.3      |
| CAT-PPA-18 | 18"        | 5"         | 1.7      |
| CAT-PPA-22 | 22"        | 5"         | 2.0      |
| CAT-PPA-26 | 26"        | 5"         | 2.3      |

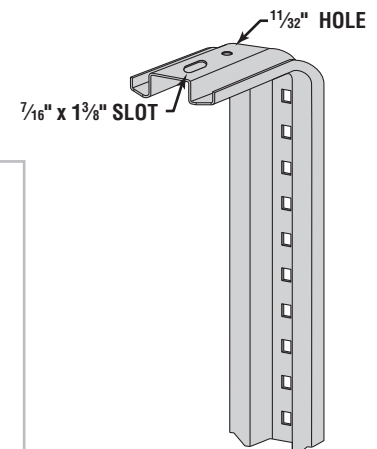
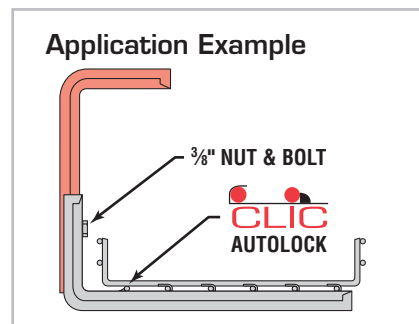

### ZED [CAT-ZBAR-120]

Weight: 11.24 lb/each

- ZED floor or wall mounted support is 1/2 x 3 1/2
- Standard finish pregalvanized (PG)
- Support is 10' long, customer cuts to size as needed
- Unique grip system requires only a push of a screwdriver to fasten the tray to the supports

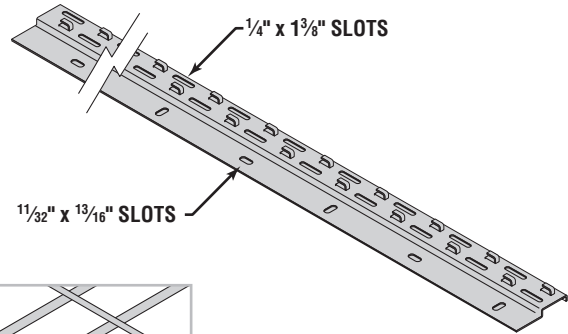

#### Application Example

PUSH TAB WITH SCREWDRIVER TO LOCK TRAY

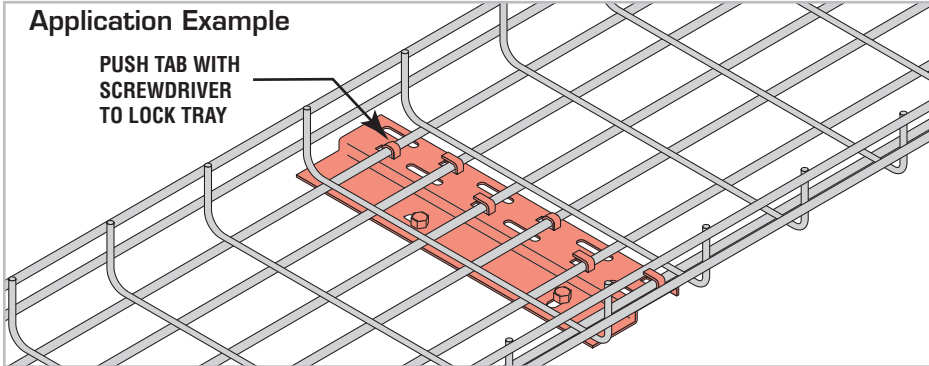

### Cantilever Medium [CAT-MWSB-(W)] & Heavy [CAT-HWSB-(W)]

- Standard finish is hot-dipped galvanized (HG)
- Cantilever arm support 1 5/8 x 1 5/8" or 1 5/8 x 1 3/16" strut
- Unique Auto-Lock system requires no hardware to fasten the tray to the supports
- Use Strut Profile to support other items below the support bracket using strut hardware

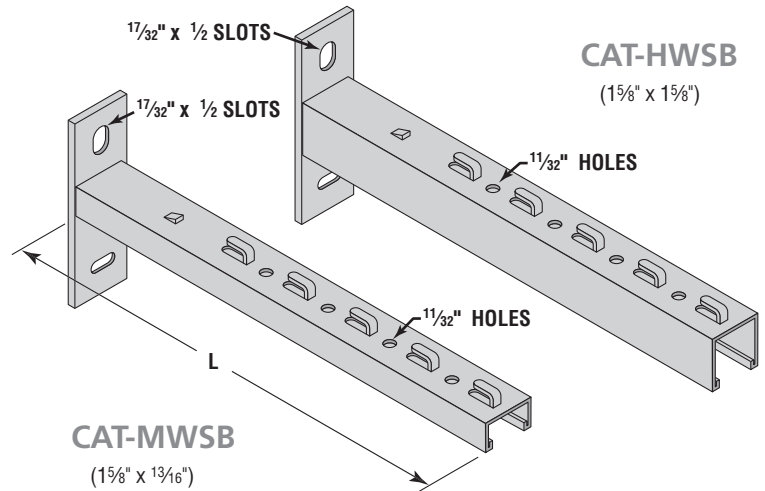

CAT-HWSB  
(1 5/8" x 1 5/8")

CAT-MWSB  
(1 5/8" x 1 3/16")

| Part No.    | Channel Size     | Tray Width (W) | Length (L) | Wt (Lbs) | Load (Lbs) |
|-------------|------------------|----------------|------------|----------|------------|
| CAT-MWSB-06 | 1 5/8" x 1 3/16" | 6"             | 8"         | 1.3      | 270        |
| CAT-MWSB-08 | 1 5/8" x 1 3/16" | 8"             | 10"        | 1.5      | 225        |
| CAT-MWSB-12 | 1 5/8" x 1 3/16" | 12"            | 14"        | 1.9      | 157        |
| CAT-HWSB-08 | 1 5/8" x 1 5/8"  | 8"             | 10"        | 1.9      | 562        |
| CAT-HWSB-12 | 1 5/8" x 1 5/8"  | 12"            | 14"        | 2.5      | 450        |
| CAT-HWSB-18 | 1 5/8" x 1 5/8"  | 18"            | 18"        | 3.0      | 337        |
| CAT-HWSB-20 | 1 5/8" x 1 5/8"  | 20"            | 22"        | 3.6      | 292        |
| CAT-HWSB-24 | 1 5/8" x 1 5/8"  | 24"            | 26"        | 4.1      | 247        |

#### Application Example

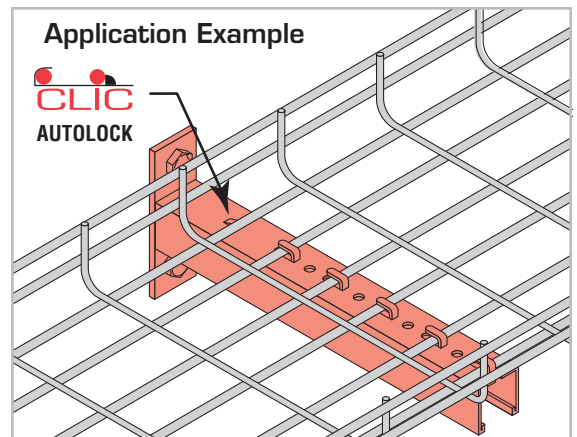

## HANGERS

### Hanger [CAT-HGR-2]

- Standard finish is pregalvanized (PG)
- Ceiling or center hung with threaded rod

NOTE: For use with CAT2-02 only

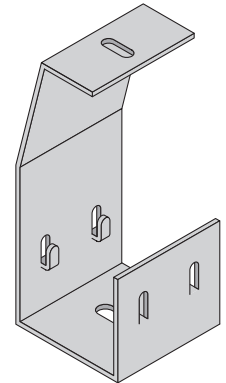
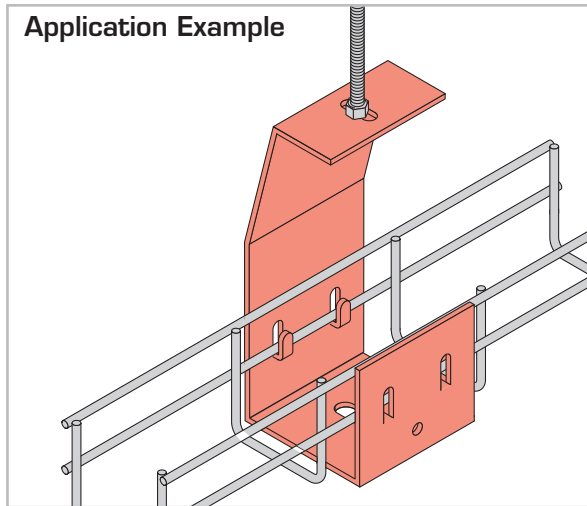

### Hanger [CAT-HGR-4]

- Standard finish is pregalvanized (PG)
- Ceiling or center hung with threaded rod

NOTE: For use with CAT2-04 or CAT4-04 only

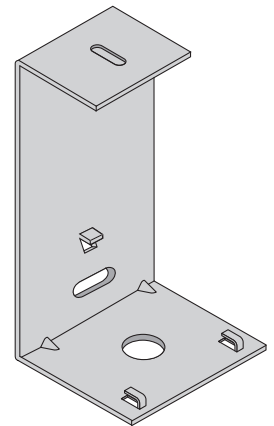
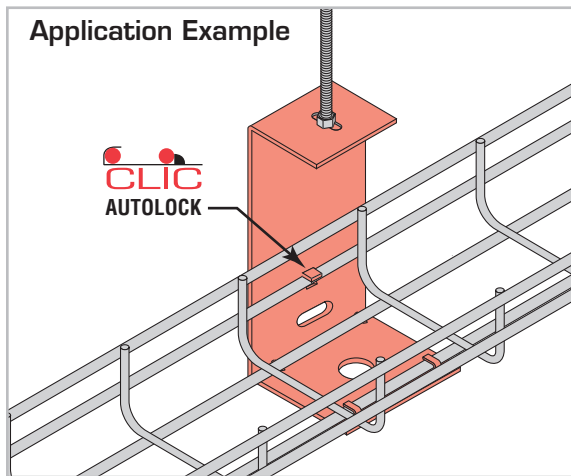

### Wall Bracket [CAT-WC-2]

- Standard finish is pregalvanized (PG)

NOTE: For use with CAT2-02 only

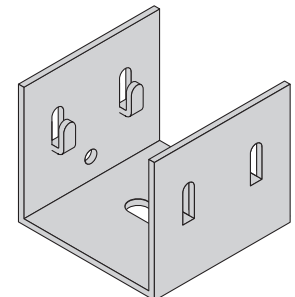
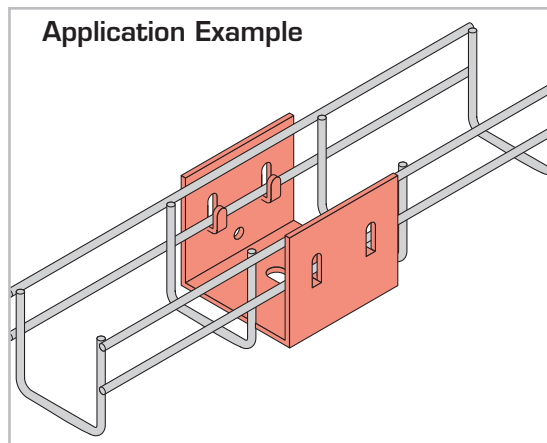

### Single Channel Pendant [PS 651-(L)]

- Standard finish is electro-galvanized (EG)

| Part No. | Length (L) | Uniform Load | Weight |
|----------|------------|--------------|--------|
| PS651-06 | 6"         | 1,200        | 1.85   |
| PS651-12 | 12"        | 600          | 2.93   |
| PS651-18 | 18"        | 400          | 4.01   |
| PS651-24 | 24"        | 300          | 5.09   |

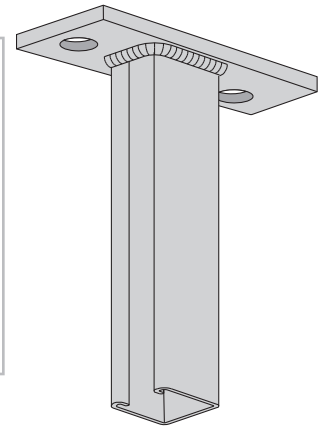
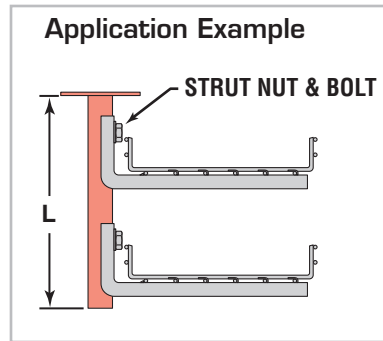

### Back-to-Back Channel Pendant [PS 809-(L)]

- Standard finish is electro-galvanized (EG)

| Part No. | Length (L) | Uniform Load | Weight |
|----------|------------|--------------|--------|
| PS809-12 | 12"        | 2,000        | 5.02   |
| PS809-18 | 18"        | 1,300        | 6.92   |
| PS809-24 | 24"        | 1,000        | 8.82   |
| PS809-30 | 30"        | 800          | 10.72  |
| PS809-36 | 36"        | 650          | 12.62  |

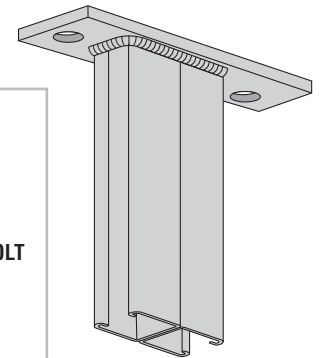
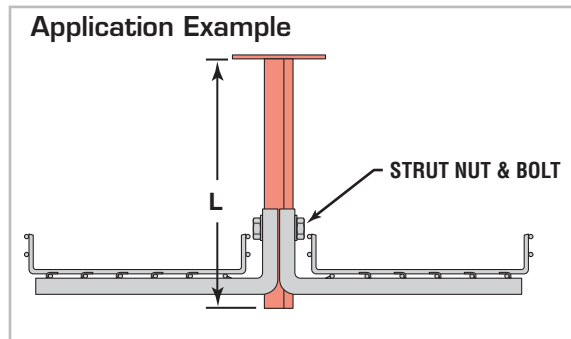

### Hanging Bracket [CAT-CB-USB]

Weight: .8 lb/each

- Standard finish is pregalvanized (PG)
- For Use with CAT-USB-120 Style Support Bracket Channel

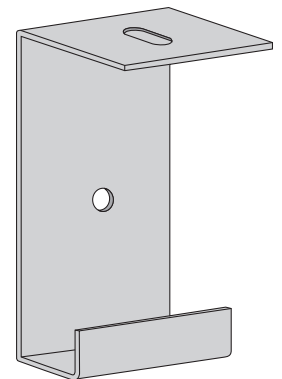
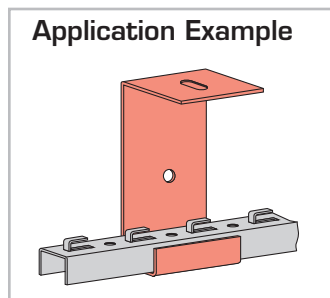
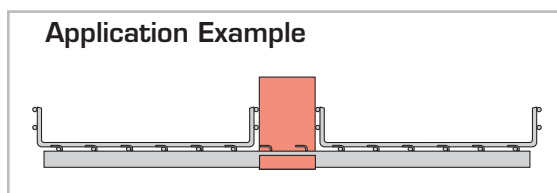

## HANGING BRACKETS

### Hanging Bracket [CAT-AB-USB]

Weight: .53 lb/each

- Standard finish is pregalvanized (PG)
- For use with CAT-USB-120 Support Bracket Channel

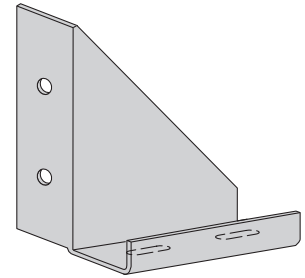
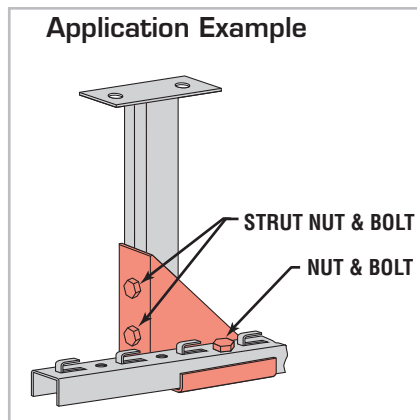
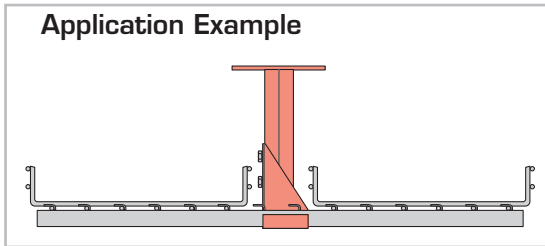

### Hanging Bracket [CAT-AB-HSB]

Weight: .62 lb/each

- Standard finish is hot-dipped galvanized (HG)
- For Use with:
  - CAT-MSB-10 Medium Support Bracket Strut
  - CAT-HSB-10 Heavy Support Bracket Strut

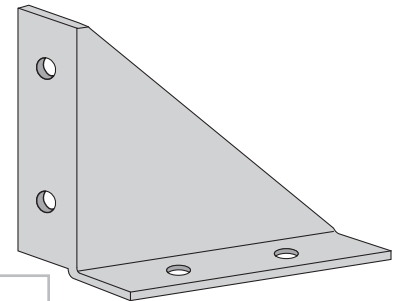
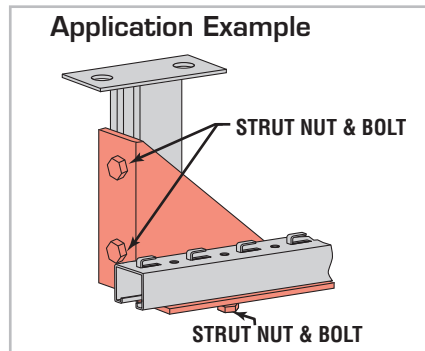
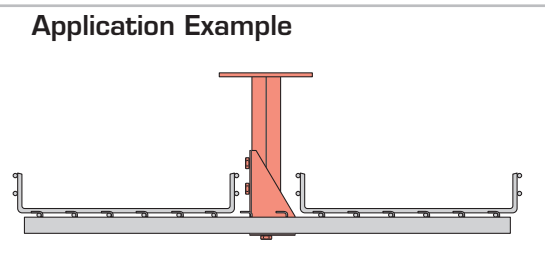

### Hanging Bracket [CAT-CB-MSB]

Weight: 1.46 lb/each

- Standard finish is pregalvanized (PG)
- For Use with:
  - CAT-MSB-10 Medium Support Bracket Strut

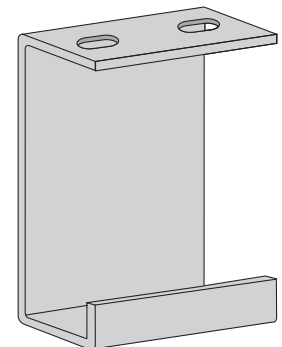
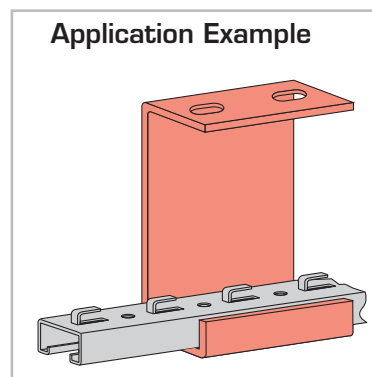
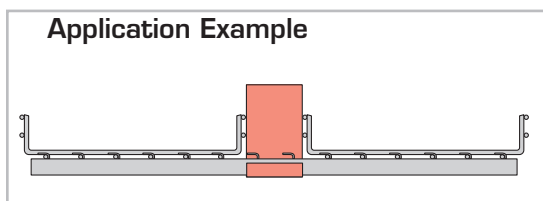

### Hanging Bracket [CAT-CB-HSB]

Weight: 2.98 lb/each

- Available in pregalvanized (PG) or hot-dipped galvanized (HG)
- For Use with:
  - CAT-MSB-10 Medium Support Bracket Strut
  - CAT-HSB-10 Heavy Support Bracket Strut

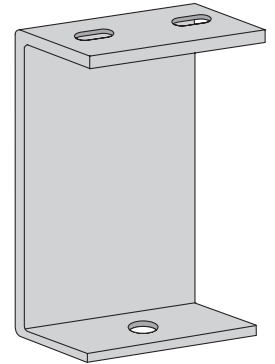
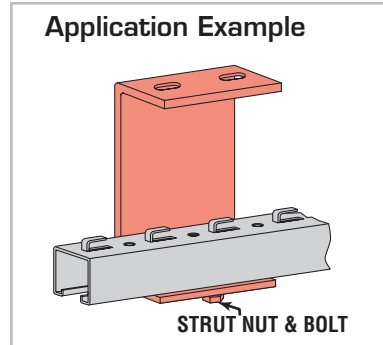
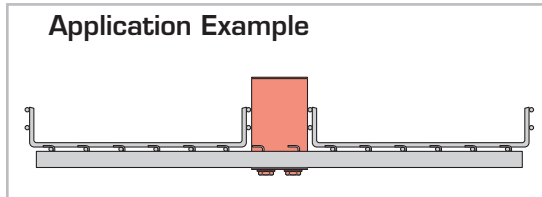

### Bracket [CAT-CMA-(W)]

- Standard finish is pregalvanized (PG)
- Mounted on cantilever arms or channels
- Easy mounting of the bracket using grips and autolock
- Designed for use with new/existing 1 5/8" strut framing

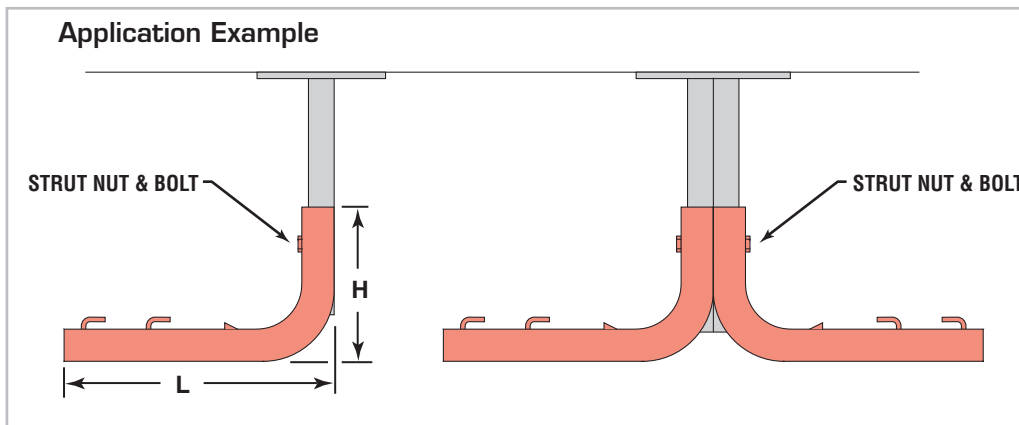
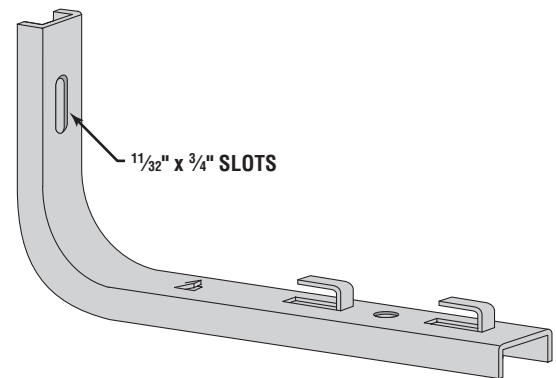

| Part No.   | Tray Width (W) | Height (H) | Length (L) | Wt (Lbs) | Load (Lbs) |
|------------|----------------|------------|------------|----------|------------|
| CAT-CMA-04 | 4"             | 4.7"       | 5"         | 0.8      | 360        |
| CAT-CMA-06 | 6"             | 4.7"       | 7"         | 1.0      | 270        |
| CAT-CMA-08 | 8"             | 4.7"       | 9"         | 1.1      | 180        |
| CAT-CMA-12 | 12"            | 4.7"       | 13"        | 1.5      | 135        |

## PEDESTAL BRACKETS

### Pedestal Brackets [CAT-PED-06] & [CAT-PED-12]

- Channel use on pedestal for raised floor
- Attach to pedestal using U-Bolt & nuts (included)

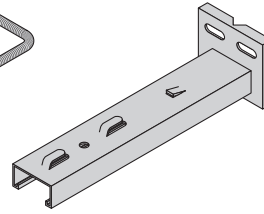
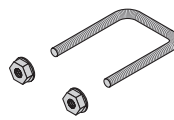

CAT-PED-06

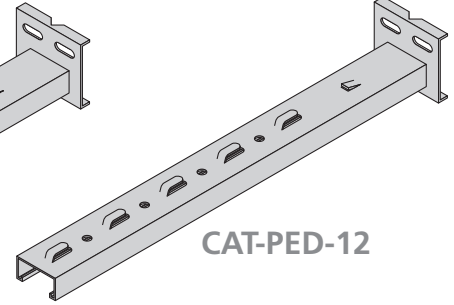

CAT-PED-12

#### Application Example

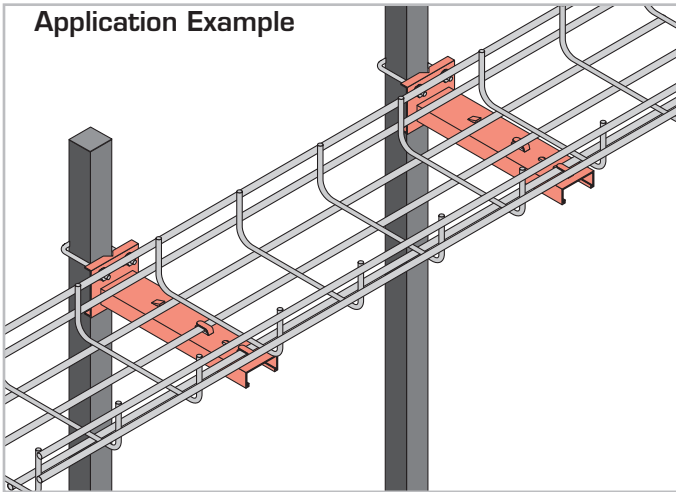

#### Application Example

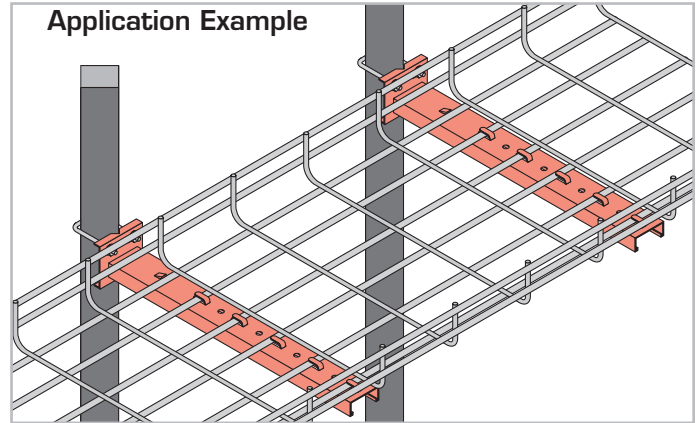

### Pedestal Kit [CAT-PED-KIT]

- Channel use on pedestal for raised floor
- Attach to pedestal using U-Bolt & nuts (included)

#### Application Example

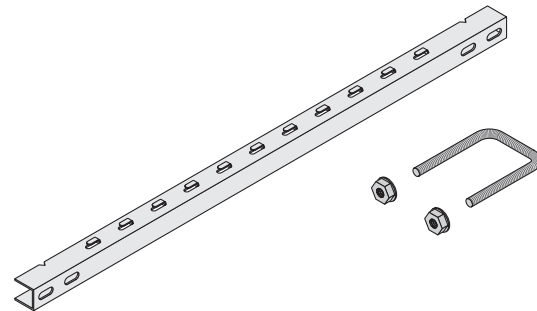
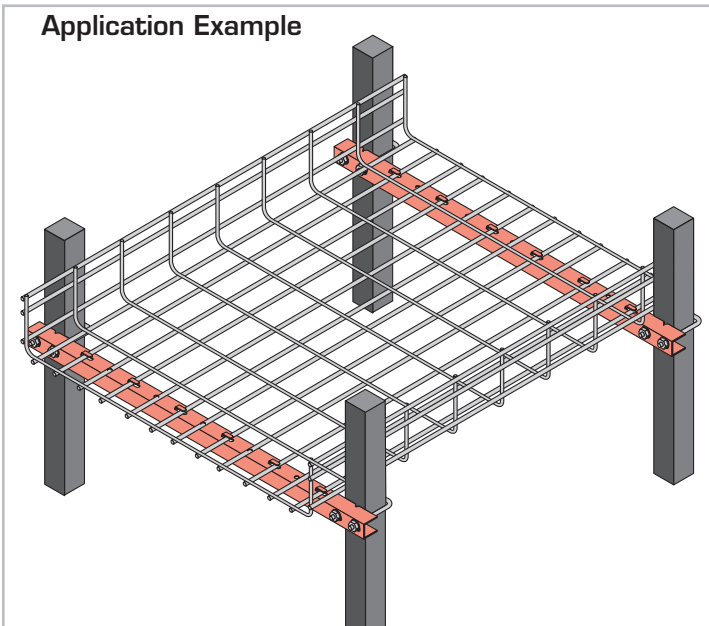

#### Application Example

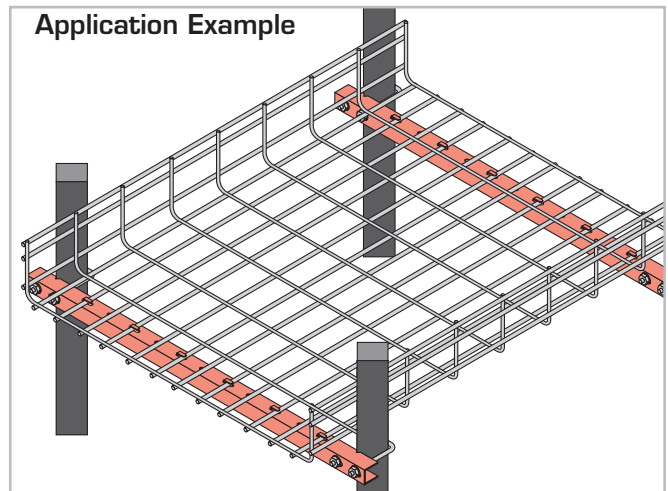

### Cover [CAT-CVR-(W)]

- Standard finish is pregalvanized (PG)
- Length is 10'

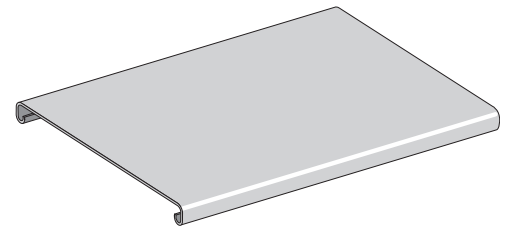

| Part       | WEIGHT (lb) |
|------------|-------------|
| CAT-CVR-02 | 5.29        |
| CAT-CVR-04 | 7.93        |
| CAT-CVR-06 | 10.58       |
| CAT-CVR-08 | 13.22       |
| CAT-CVR-12 | 18.52       |
| CAT-CVR-16 | 35.71       |
| CAT-CVR-18 | 39.68       |
| CAT-CVR-20 | 43.65       |
| CAT-CVR-24 | 51.53       |

#### Application Example

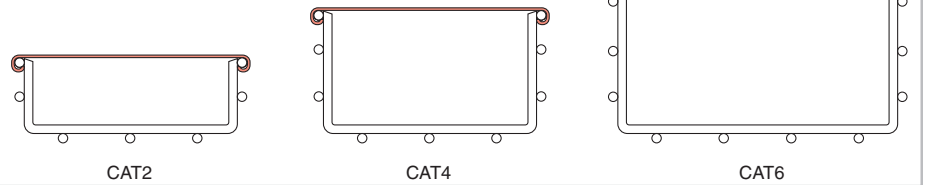

### Tray Dividers [CAT2-01SB-120], [CAT4-01SB-120], & [CAT6-01SB-120]

- Standard finish is pregalvanized (PG)
- Locks into tray with auto-lock tabs (no hardware required)
- Cut "V" notches into bottom flange to make barriers for flat fittings

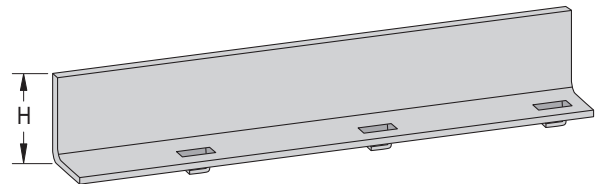

#### Application Example

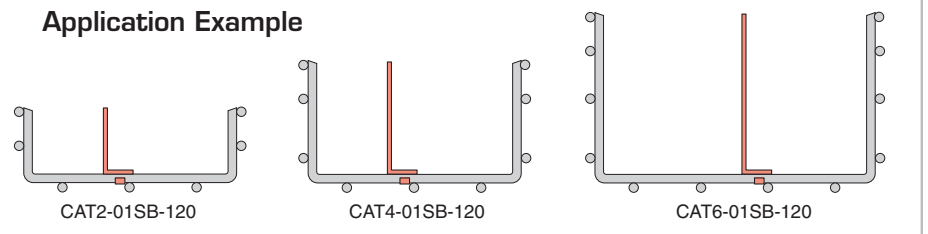

### Drop Out [CAT-(W)DO]

- Standard finish is pregalvanized (PG)
- CAT-UNI-DO can be used in any 2" x 4" mesh opening or as a "side-out"

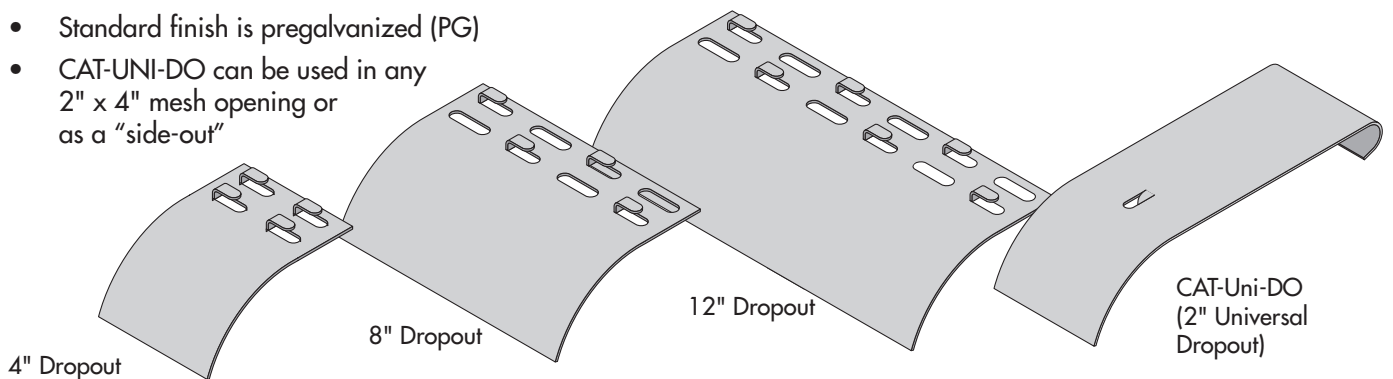

#### Application Example

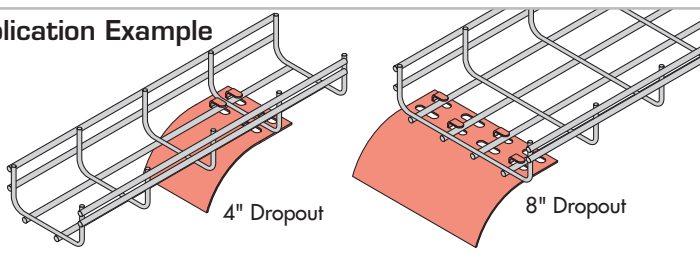

#### Application Example

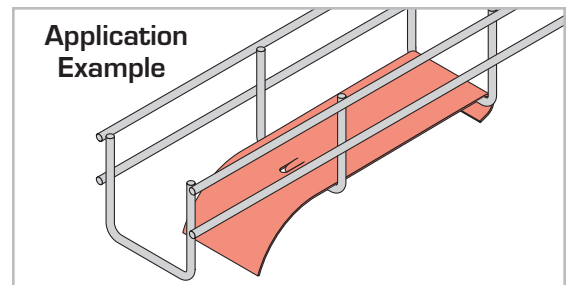

## ACCESORIES

### Blind End [CAT(H)-(W)BE]

- Standard finish is pregalvanized (PG)
- Standard use per blind end is:  
(2 pc) CH3 (sold separately)

**NOTES:**

1. Always place nut on outside of tray

| Part      | WEIGHT (lb) |
|-----------|-------------|
| CAT2-04BE | .18         |
| CAT2-06BE | .22         |
| CAT2-08BE | .28         |
| CAT2-12BE | .40         |
| CAT2-16BE | .50         |
| CAT2-18BE | .57         |
| CAT2-20BE | .64         |
| CAT2-24BE | .70         |

| Part      | WEIGHT (lb) |
|-----------|-------------|
| CAT4-04BE | .52         |
| CAT4-08BE | .64         |
| CAT4-12BE | .76         |
| CAT4-16BE | .96         |
| CAT4-18BE | 1.08        |
| CAT4-20BE | 1.20        |
| CAT4-24BE | 1.44        |

| Part      | WEIGHT (lb) |
|-----------|-------------|
| CAT6-08BE | 0.82        |
| CAT6-12BE | 1.12        |
| CAT6-16BE | 1.42        |
| CAT6-18BE | 1.57        |
| CAT6-20BE | 1.72        |
| CAT6-24BE | 2.10        |

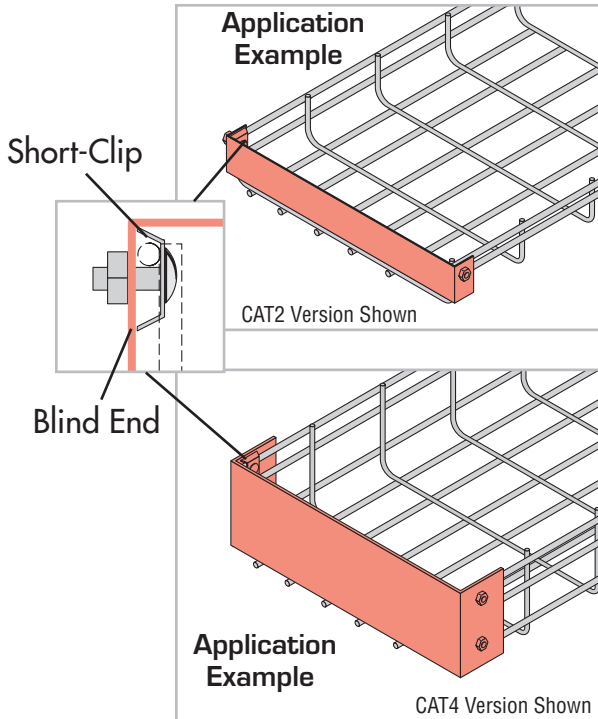
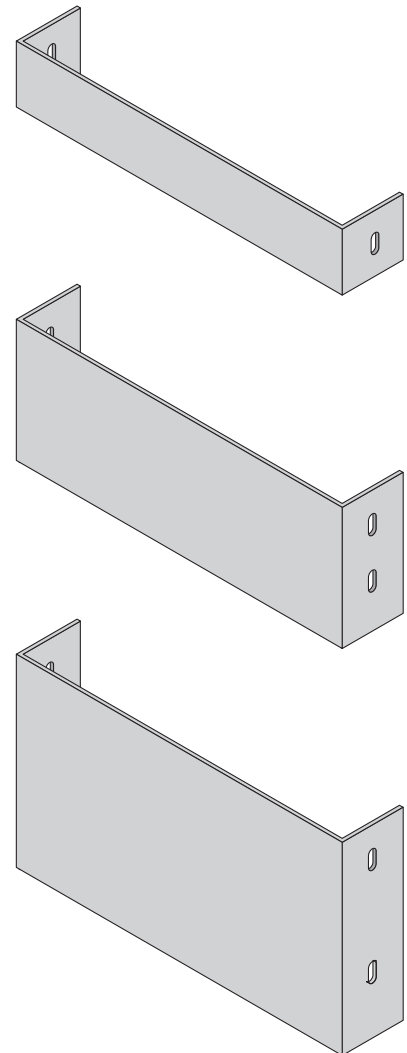

### Box Connector [CAT(H)-(W)CB]

- Standard finish is pregalvanized (PG)
- Standard use per box connector is:  
(2 pc) CH3  
(5 pc) EG-CBN  
(both sold separately)

**NOTES:**

1. Always place nut on outside of tray
2. For use with CAT2, CAT4 & CAT6 tray only

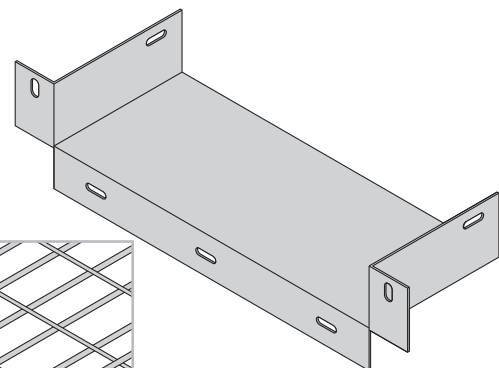
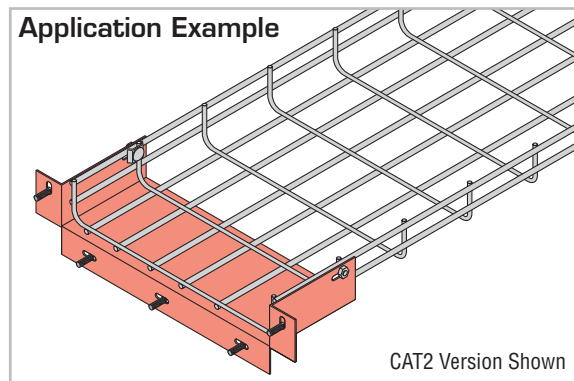

### Lighting Bracket [CAT-HLT]

- Standard finish is pregalvanized (PG)

#### Application Example

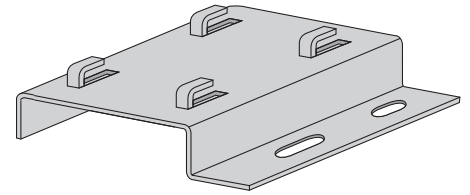
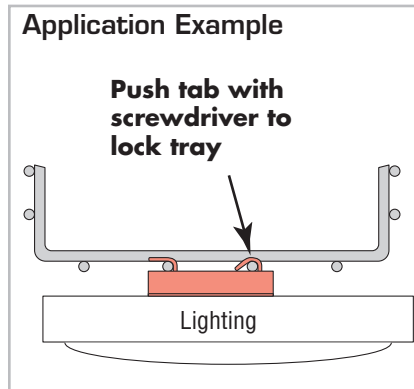

### Electrical Box Bracket [CAT-EBC]

- Standard finish is pregalvanized (PG)

#### Application Example

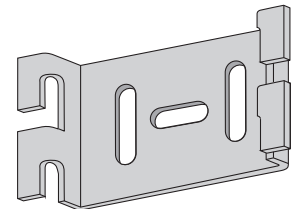
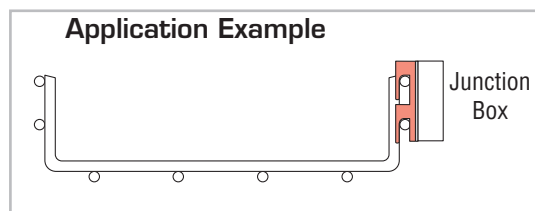

### Wall Sleeve [CAT(H)-(W)WS]

- Standard finish is pregalvanized (PG)
- Standard use per wall sleeve is:
  - (4 pc) CH3      (5 pc) 6112-0
  - (4 pc) 5003-1    (4 pc) 5009-1
  - (8 pc) EM -CC
  - (all sold separately)

#### NOTES:

- Always place nut on outside of tray
- Example CAT2-12WS

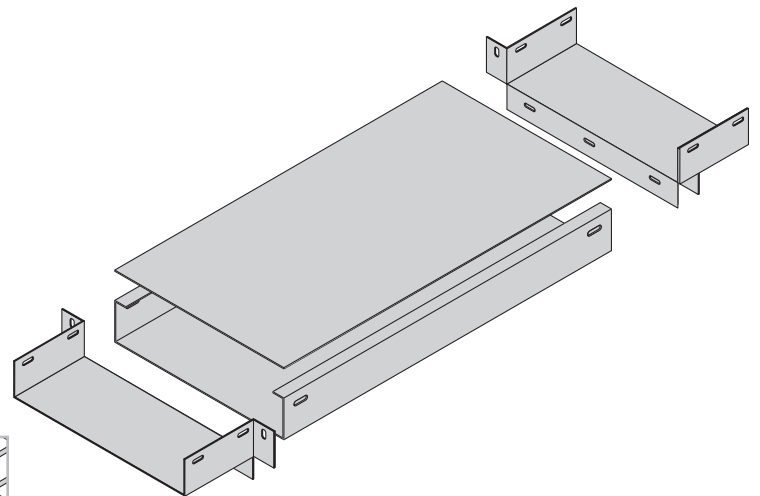

#### Application Example

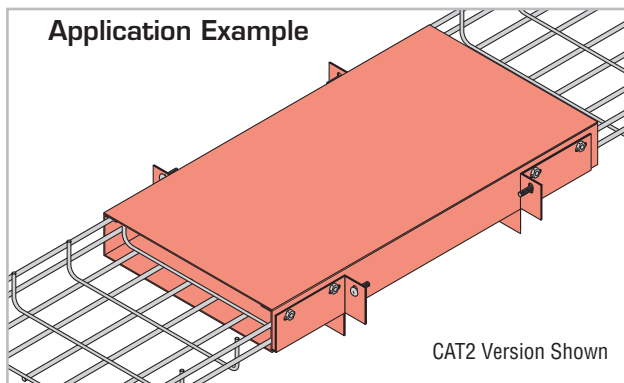

## FITTINGS OVERVIEW

### Fittings Overview

Fittings are typically fabricated on the job. However, prefabricated fittings are available upon request. Please contact factory.

To determine the fitting hardware required to create a set of fittings, please consult our sales department.

**Tee and Cross**

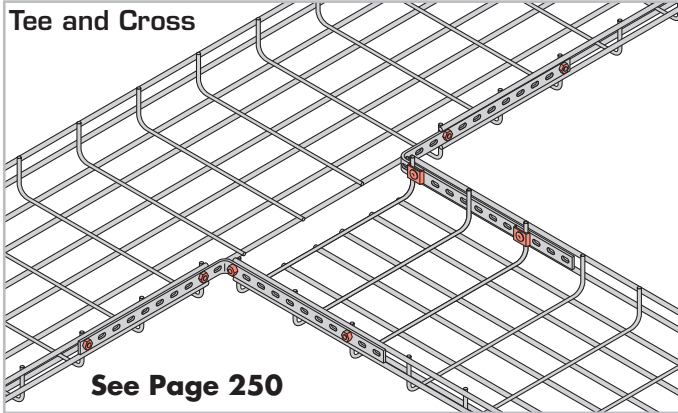

**See Page 250**

**90° Short Radius Bend**

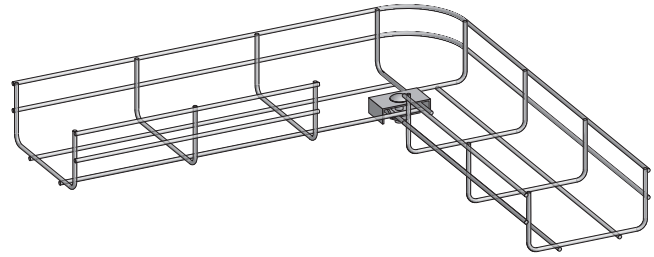

**See Pages 248 - 249**

**90° Long Radius Bend**

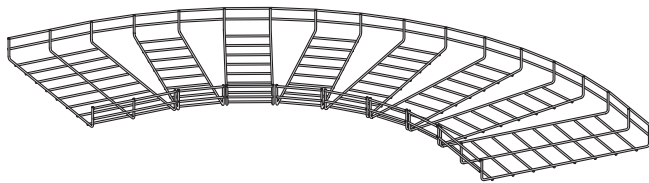

**See Page 247**

**Risers**

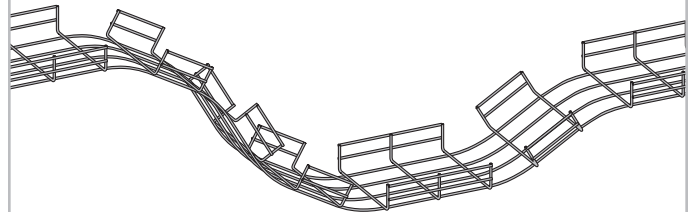

**See Page 251**

### Cutting Tool [CAT-CUT]

Fittings can be formed easily on-site by cutting the bottom and side wires. Cut the tray bars on an angle as shown in the illustration.

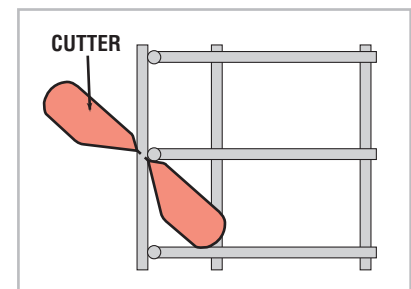
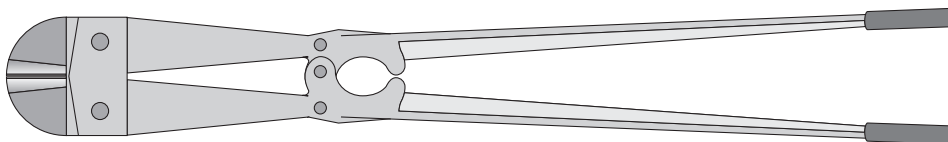

**NOTE:** When cutting, keep the remaining sharp edge away from the inside of the tray.

### 90° Bends - Long Radius

#### 1 CUT THE BOTTOM AND SIDE WIRES

To form 90° bends in the tray, cut out the number of sections shown below based on the width of the tray used



#### 2 ASSEMBLE USING APPROPRIATE HARDWARE

- Standard hardware is shown with each bend size.

#### Advantages:

- Use as bonding jumper
- Vertical support of standing sections
- Adjustable radius allowances

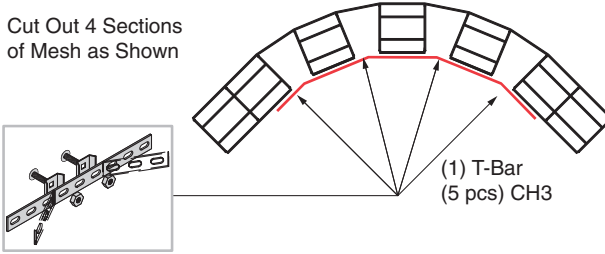
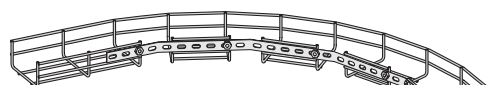
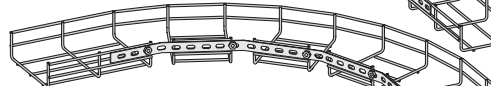
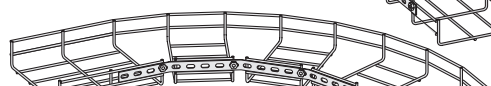
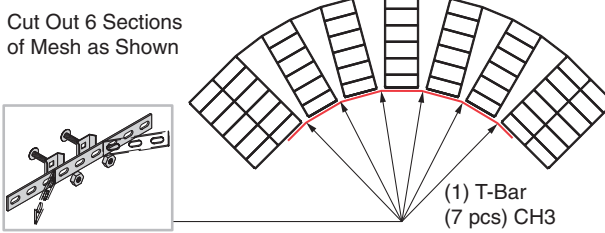
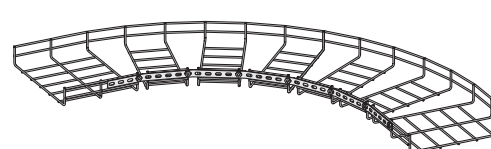
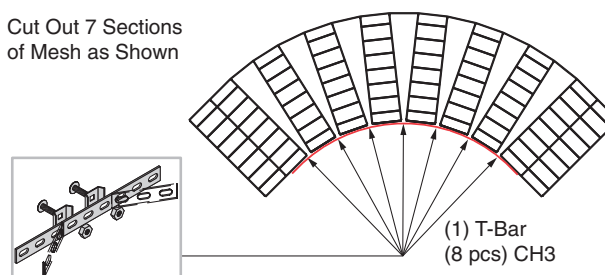
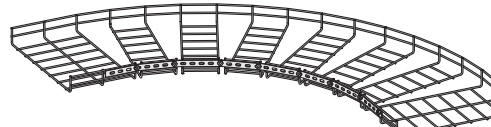
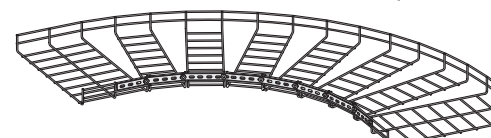
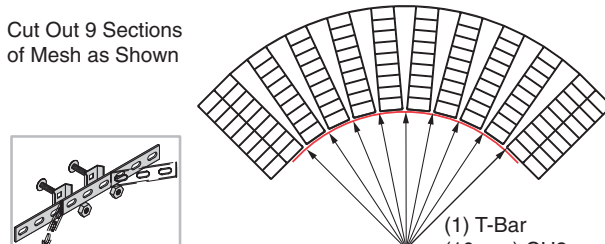
NOTE: Always place nut on outside of tray

|  |                                   |  |  |
|--|-----------------------------------|--|--|
| <p>Cut Out 4 Sections of Mesh as Shown</p>    | <p>(1) T-Bar<br/>(5 pcs) CH3</p>  |    | <p>CAT2-04<br/>16" Inside Radius</p> <p>CAT2-06<br/>12" Inside Radius</p> <p>CAT2-08<br/>12" Inside Radius</p> |
| <p>Cut Out 6 Sections of Mesh as Shown</p>   | <p>(1) T-Bar<br/>(7 pcs) CH3</p>  |   | <p>CAT2-12<br/>17" Inside Radius</p>   |
| <p>Cut Out 7 Sections of Mesh as Shown</p>  | <p>(1) T-Bar<br/>(8 pcs) CH3</p>  |    | <p>CAT2-16<br/>18" Inside Radius</p> <p>CAT2-18<br/>18" Inside Radius</p>                                      |
| <p>Cut Out 9 Sections of Mesh as Shown</p>  | <p>(1) T-Bar<br/>(10 pcs) CH3</p> |    | <p>CAT2-20<br/>24" Inside Radius</p> <p>CAT2-24<br/>24" Inside Radius</p>                                      |

## 90° SHORT RADIUS BENDS

### 90° Bends - Forming Instructions

To form 90° bends in the tray, cut the wires shown in the color shaded area of the drawing which corresponds to the width of the tray used.

#### 1 CUT THE BOTTOM AND SIDE WIRES

Bends can be formed easily on-site by cutting the bottom and side wires. The shaded areas indicated should be cut and removed. Then, simply bend Wire basket tray cable tray to form a 90° angle and you are ready to install. Make sure you use the appropriate hardware.

#### 2 ASSEMBLE USING APPROPRIATE HARDWARE

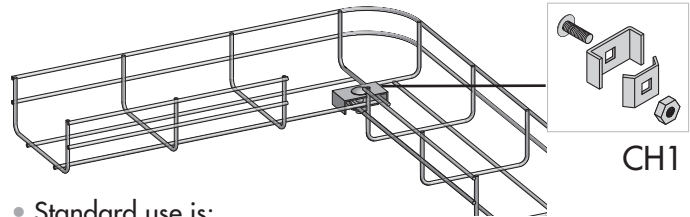

- Standard use is:  
 Sizes 4" - 12" (1 pc) CH1  
 Sizes 16" - 24" (2 pc) CH1

NOTE: Always place nut on outside of tray

### 90° Bends - Cutting Diagrams

#### 4" (100mm)

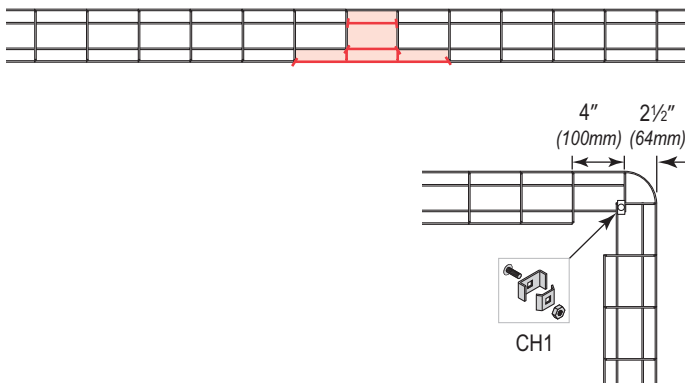

#### 6" (150mm)

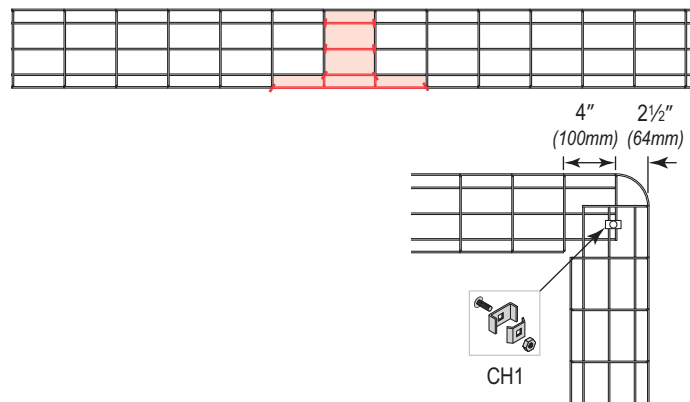

#### 8" (200mm)

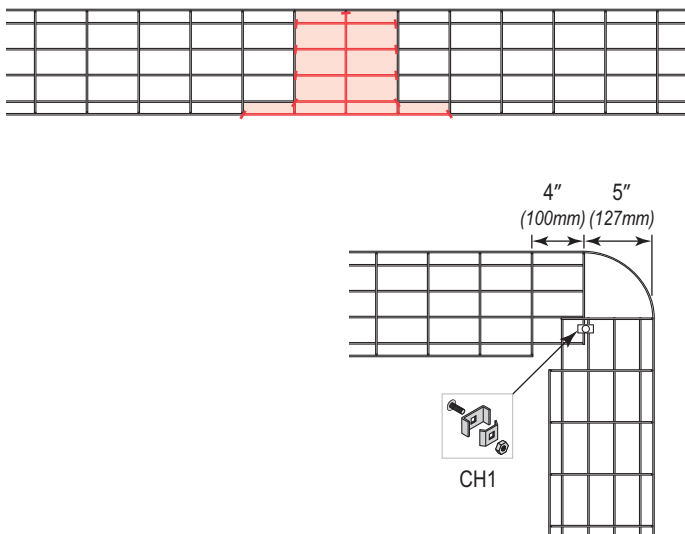

#### 12" (300mm)

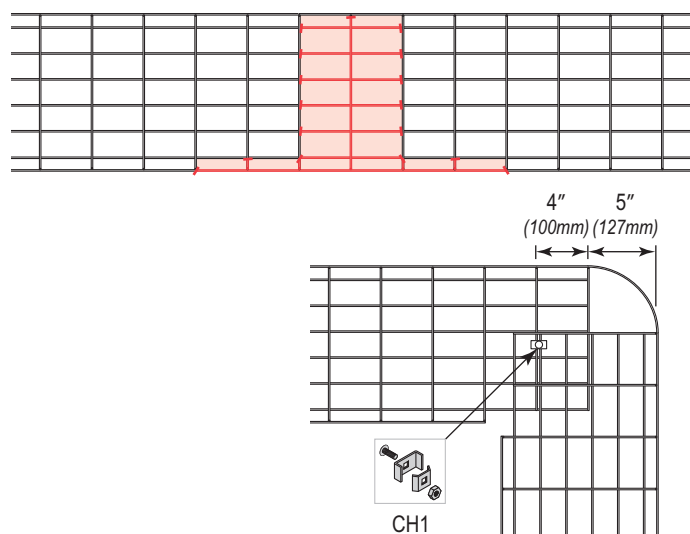

### 90° Bends - Cutting Diagrams

**16" (400mm)**

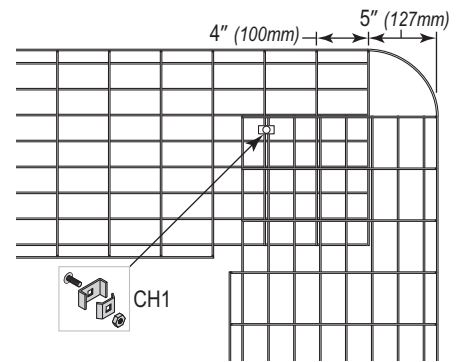
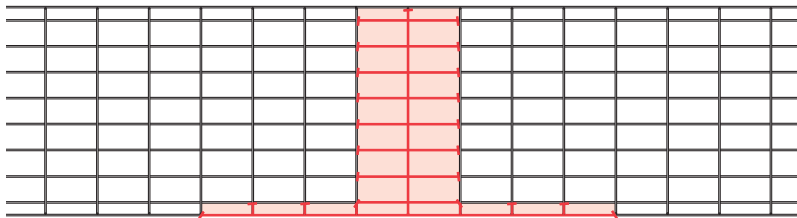

**18" (450mm)**

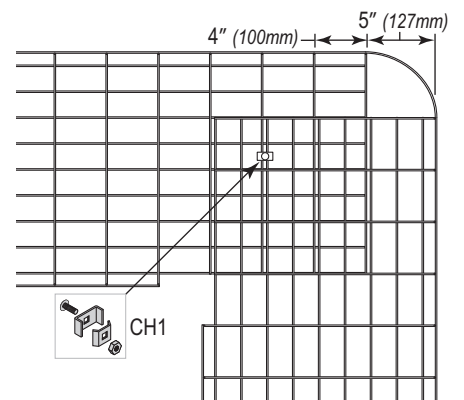
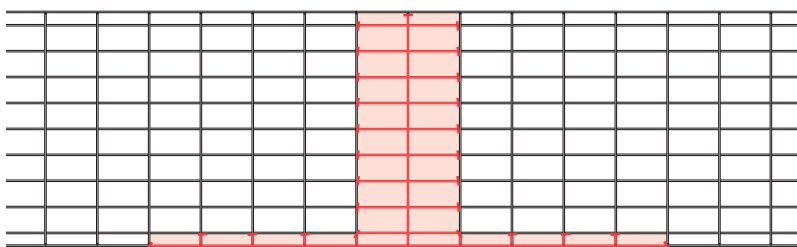

**20" (500mm)**

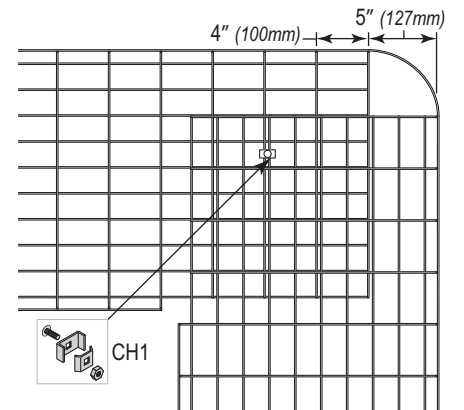
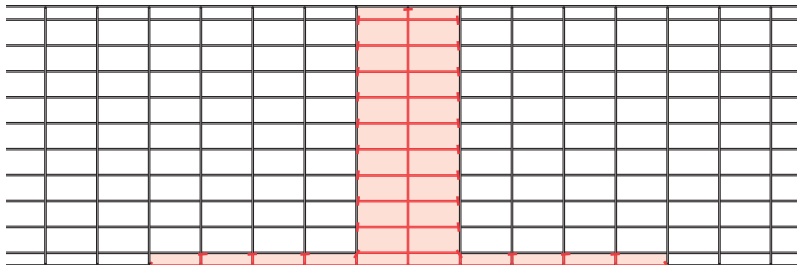

**24" (600mm)**

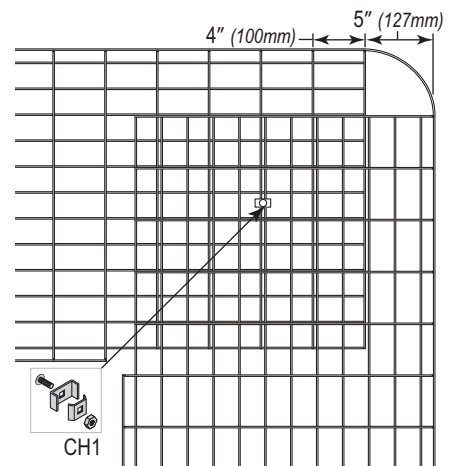
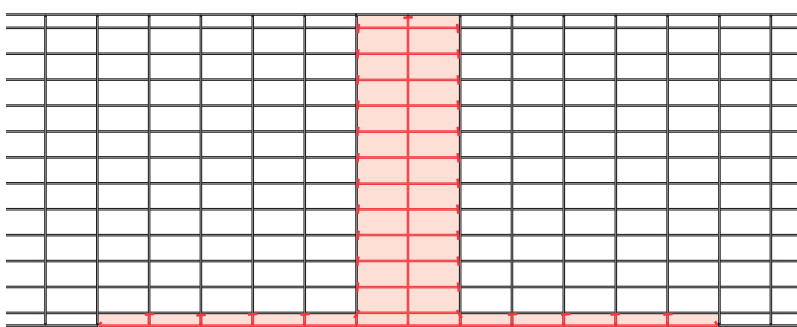

## CROSS & TEE FITTINGS

### Standard Tee

- Standard use per tee is:
  - (2 pc) T-Bar-22 or (1 pc) T-Bar cut in half
  - (8 pc) CH3

NOTE: Always place nut on outside of tray

To form a tee, cut the wires marked in yellow.

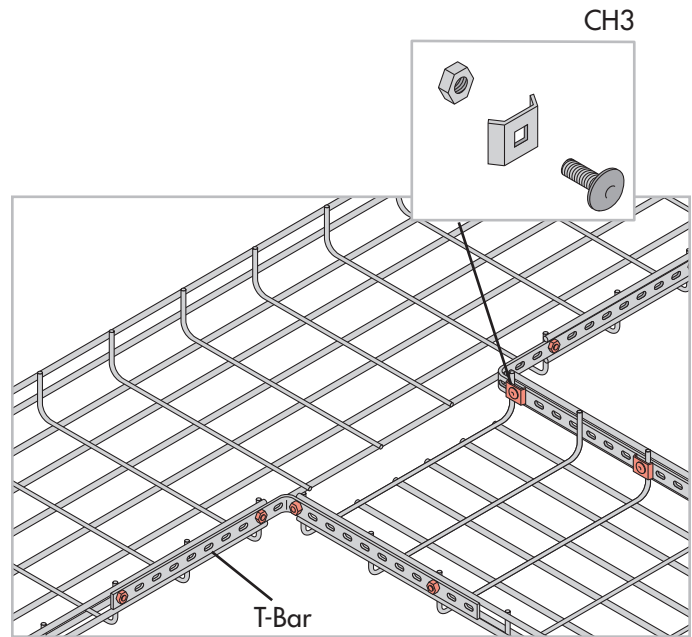
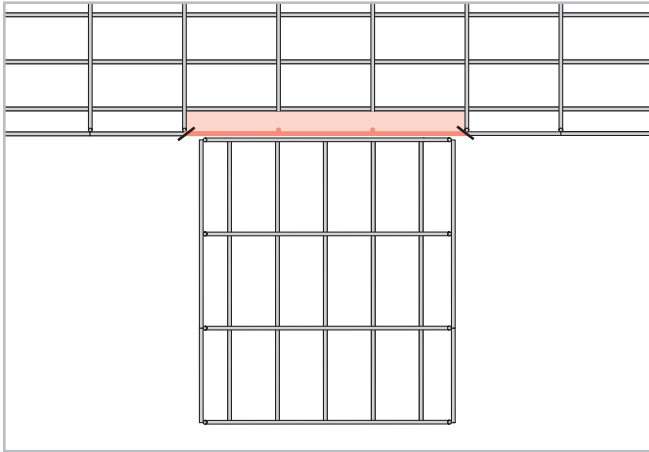

### Cross

- Standard use per cross is:
  - (4 pc) T-Bar-22 or (2 pc) T-Bar cut in half
  - (16 pc) CH3

NOTE: Always place nut on outside of tray

To form a cross, cut the wires marked in yellow.

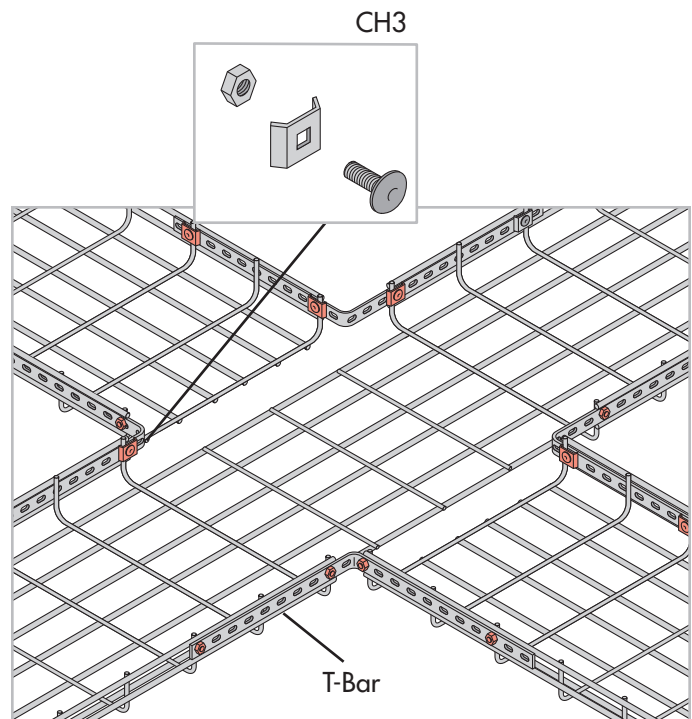
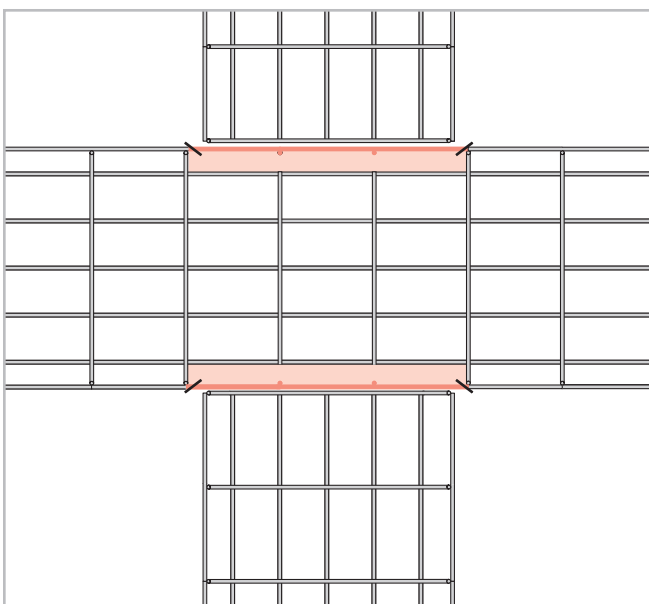

### Reducer

- Standard use per reducer is:  
(2 pc) T-bar  
(8 pc) CH3  
(1 pc) CH2

NOTE: Always place nut on outside of tray

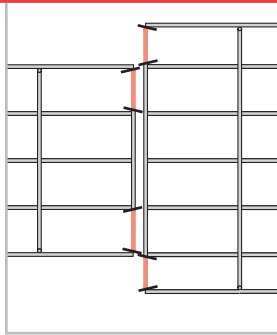

### Offset

- Standard use per offset is:  
(2 pc) T-Bar  
(8 pc) CH3  
(1 pc) CH2

NOTE: Always place nut on outside of tray

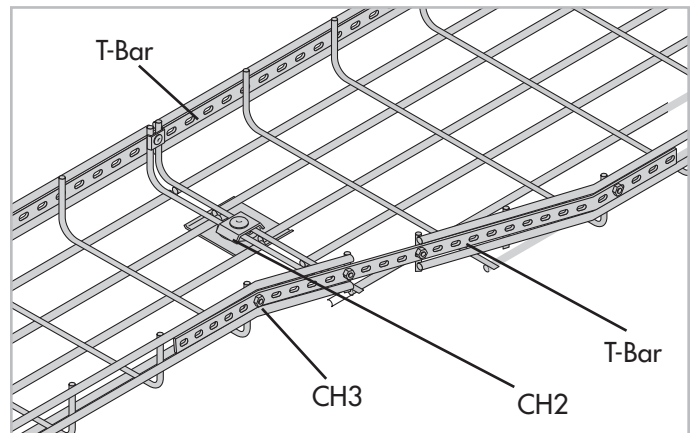
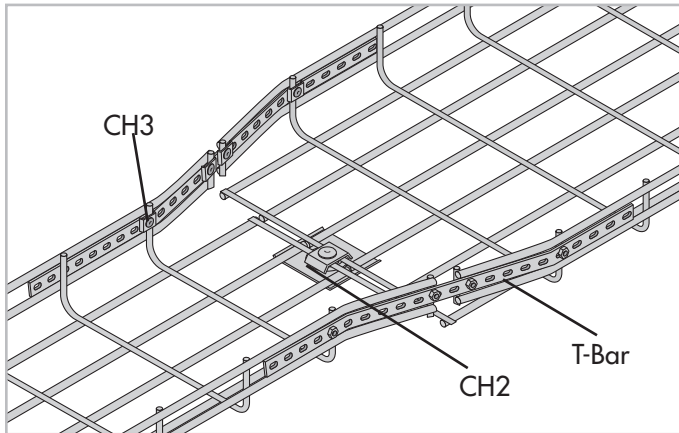
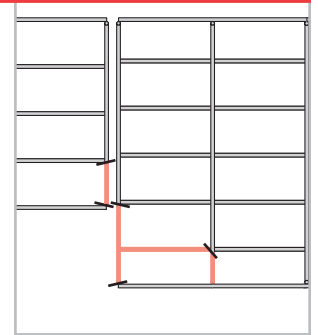

### Riser

Risers and drops can be created to avoid different obstacles in the job path. Simply cut out the required number of side mesh sections and bend a vertical riser or drop to fit the application.

Cut out 4 side sections of mesh for a soft 90° bend.

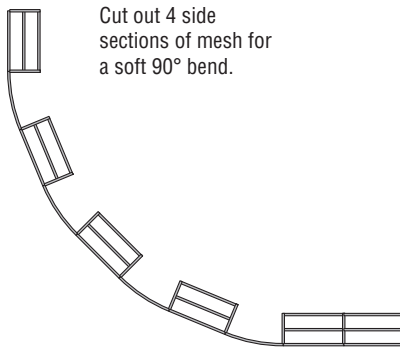

Cut out 3 side sections of mesh for a 90° bend.

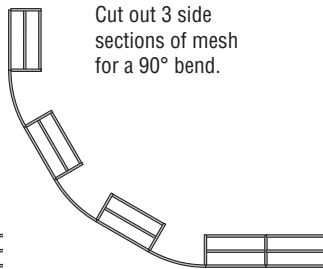

Cut out 2 side sections of mesh for a 90° bend.

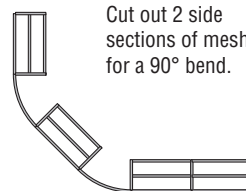

Cut out 1 side sections of mesh for a hard 90° bend.

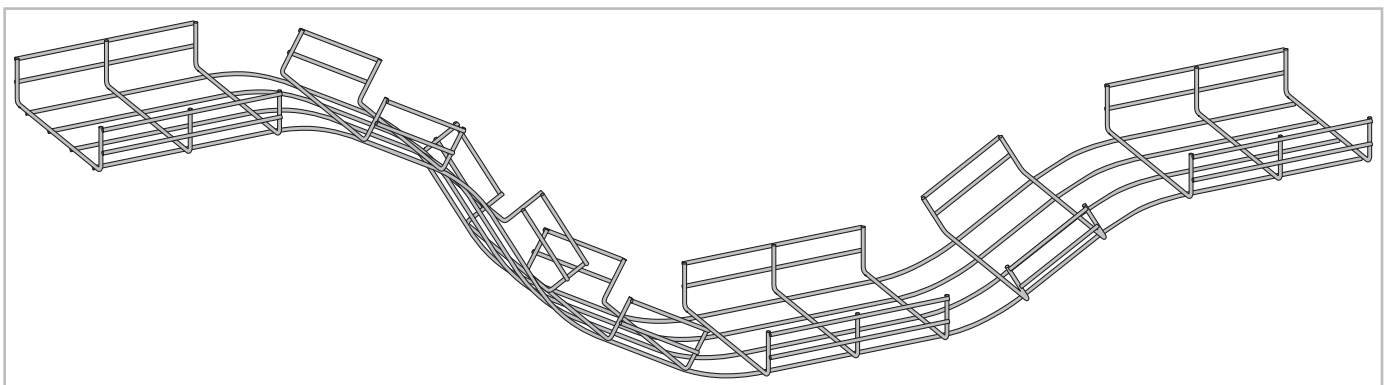
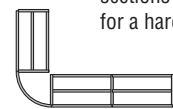

## GROUNDING

### Grounding

#### UL CLASSIFIED SYSTEMS

The Cope brand of wire basket systems which meet the UL Classification are referenced on pages 228 & 229.

Notes: Cope recommends use of a separate ground wire for equipment grounding.

Any non-conductive coating to wire basket must be removed by the contractor/end-user to maintain electrical continuity.

**Straight Sections** - The grounding of two straight sections requires the use of (2) CAT-GC's and (2) EG-CBN's.

These items consist of grounding clips and the appropriate hardware, for connecting to the trays. One clip should be placed on both sides of the tray, attached at the self-splicing bar.

**Fittings** - Grounding of fittings requires special attention. Typically, fittings are fabricated in the field by cutting straight sections, thus altering the cross sectional area of the tray. A bonding jumper, and/or a T-Bar Splice, along with the appropriate hardware must be used on either side of the fitting to ensure electrical continuity.

#### Straights

2 pcs of CAT-GC  
2 pcs of EG-CBN

#### EG-CBN

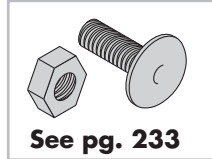

See pg. 233

#### Application Example

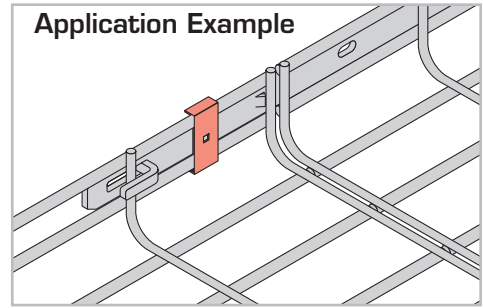

#### Fittings

T-Bar and  
CH3s

#### Application Example

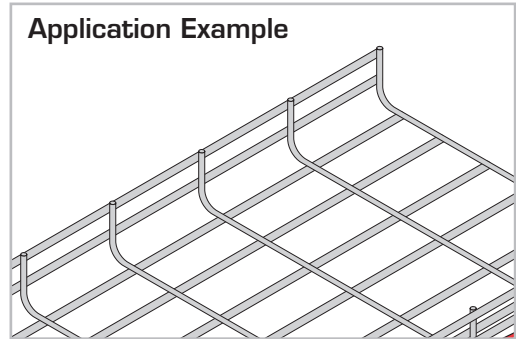

### Grounding Clip [CAT-GC]

- Standard finish is pregalvanized (PG)
- Sold in packs of 10
- Connection to splice bars requires a nut and bolt assembly (EG-CBN) purchased separately
- Use on both sides of tray

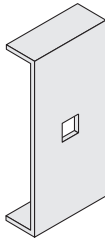

NOTE: Always place nut on outside of tray

CAT-GC's must be utilized if the tray is to be utilized as an equipment ground conductor.

### Grounding Clamp/Split Bolt [SPLIT-BOLT]

- Split bolts are utilized for the attachment of a separate ground wire.
- Use with #6 AWG Ground Conductor

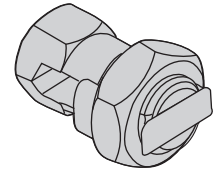

NOTE: Always place nut on outside of tray

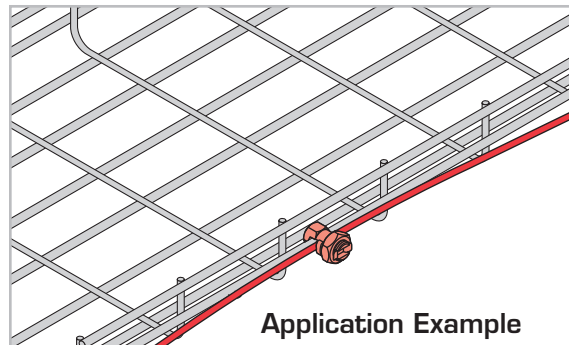

#### Application Example

## Bottom Clip [BOTTOM-CLIP]

- Bottom-clip used a hold-down clip

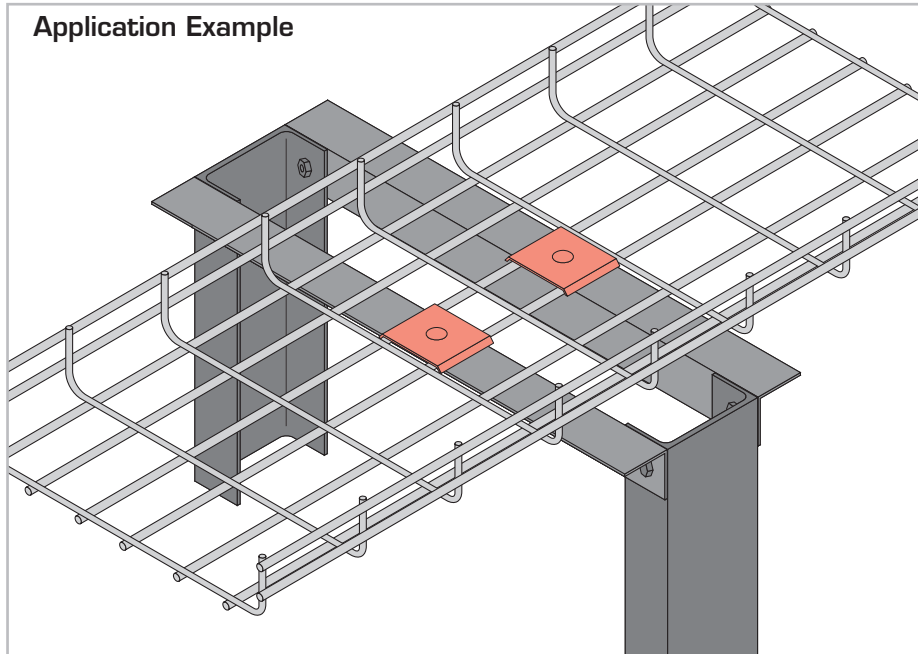
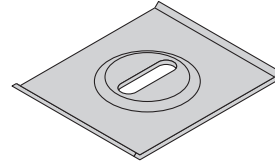

Drill hole in aluminum angle of relay rack.

Use bottom-clip to hold Wire basket tray to relay rack using 1/4"-20 round head machine screw and bolt and washer.

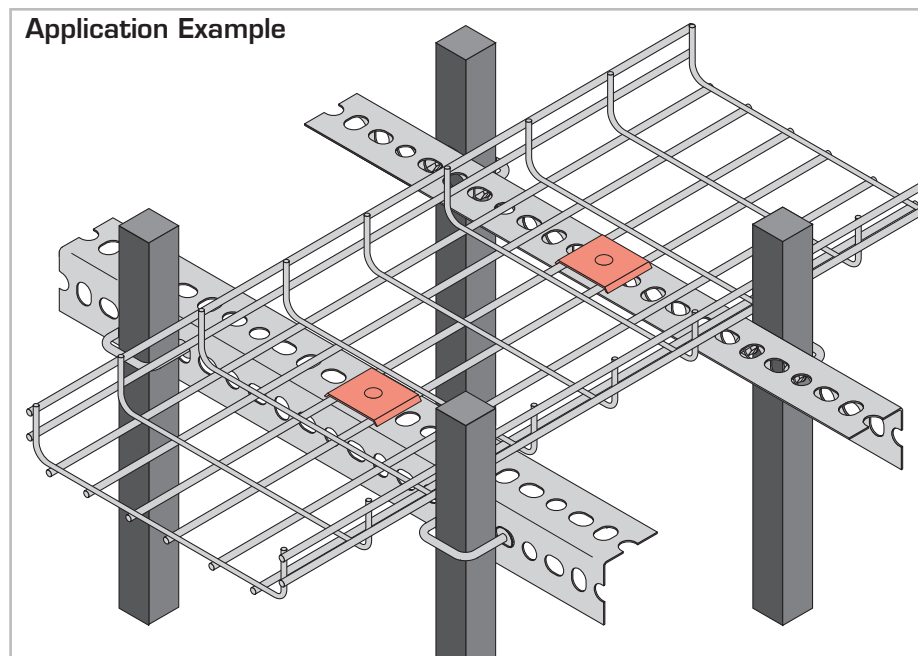

## HARDWARE

### Hex Head Cap Screws

- Standard finish is electro-galvanized (EG)

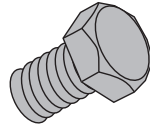

| Part No. | Description           |
|----------|-----------------------|
| E-142    | 1/4"-20 x 1" Long     |
|          | 1/4"-20 x 1 1/2" Long |
|          | 3/8"-16 x 5/8" Long   |
|          | 3/8"-16 x 1" Long     |
|          | 3/8"-16 x 1 1/2" Long |
|          | 3/8"-16 x 2" Long     |

### Hex Nuts

- Standard finish is electro-galvanized (EG)

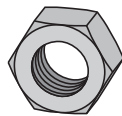

| Part No. | Description |
|----------|-------------|
| E-145    | 1/4"-20     |
|          | 3/8"-16     |
|          | 1/2"-13     |

### Flat Washers

- Standard finish is electro-galvanized (EG)

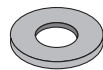

| Part No. | Description |
|----------|-------------|
| E-147    | 1/4"        |
|          | 3/8"        |
|          | 1/2"        |

### Round Head Machine Screws

- Standard finish is electro-galvanized (EG)

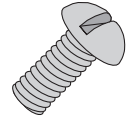

| Part No. | Description           |
|----------|-----------------------|
| E-141    | 1/4"-20 x 1" Long     |
|          | 1/4"-20 x 1 1/2" Long |
|          | 3/8"-16 x 5/8" Long   |
|          | 3/8"-16 x 1" Long     |
|          | 3/8"-16 x 1 1/2" Long |
|          | 3/8"-16 x 2" Long     |

### Square Nuts

- Standard finish is electro-galvanized (EG)

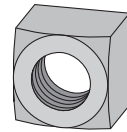

| Part No. | Description |
|----------|-------------|
| E-146    | 1/4" - 20   |
|          | 3/8" - 16   |
|          | 1/2" - 13   |

### Lock Washers

- Standard finish is electro-galvanized (EG)



| Part No. | Description |
|----------|-------------|
| E-148    | 1/4"        |
|          | 3/8"        |
|          | 1/2"        |

### Strut Nuts

- Standard finish is electro-galvanized (EG)

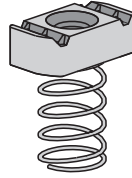

| Part No. | Description |
|----------|-------------|
| A-100    | 1/4" - 20   |
|          | 3/8" - 16   |
|          | 1/2" - 13   |

### Square Strut Washers

- Standard finish is electro-galvanized (EG)

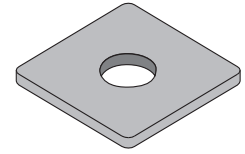

| Part No. | Description |
|----------|-------------|
| AB-241   | 1/4" hole   |
|          | 3/8" hole   |
|          | 1/2" hole   |

### Tray Clips (See Page 233 for Connector Kits)

- Standard finish is electro-galvanized (EG)

| Single Part | WEIGHT | NO./ PKG |
|-------------|--------|----------|
| Short-Clip  | .20    | 10       |
| Wide-Clip   | .31    | 10       |
| Bottom-Clip | .92    | 10       |

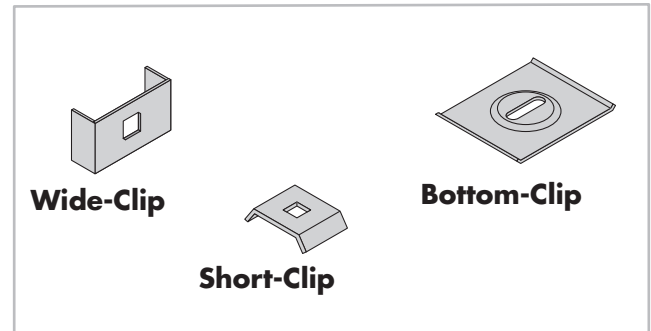

### Threaded Rod

- Standard finish is electro-galvanized (EG)

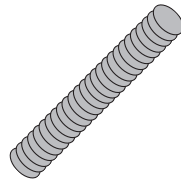

| Part No. | Description | Weight     |             |             |
|----------|-------------|------------|-------------|-------------|
|          |             | 6' Lengths | 10' Lengths | 12' Lengths |
| H-104    | 1/4" - 20   | 73         | 121         | 146         |
|          | 3/8" - 16   | 175        | 292         | 350         |
|          | 1/2" - 13   | 319        | 531         | 638         |

## Sample Specification

### 1.0 Acceptable Manufacturer

Provide "AB-Cope" Wire Basket type of cable management system as manufactured by AB-Cope standard design.

All cable trays shall be installed in a neat uniform fashion. Installing contractor shall field modify tray system to accommodate the exact routing requirements.

### 2.0 Material/Finishes

Wire basket tray to be fabricated from high strength steel wires.

#### 2.1 Acceptable finishes;

##### 2.1.a Standard Finish

**EG** – Electro-Galvanized Steel in accordance with ASTM 633 Type I SC3.

##### 2.1.b Special Finishes

**HD** – Hot dipped Galvanized Steel in accordance with ASTM 123.

**ZD** – Electro- Galvaned Steel with a Yellow

Dichromate applied over the Standard EG finish per ASTM633 type II, SC3.

**EP** – Epoxy Coated Steel.

**SS** – AISI 304L stainless or AISI 316L stainless steel.

### 3.0 - Straight Sections

Straight sections shall be manufactured from high strength steel wires forming 2" X 4" openings and shall conform to the following dimensions

#### 3.1 Length

Straight sections shall be supplied in 10' lengths

#### 3.2 Width

Widths shall be 2", 4", 6", 8", 12", 16", 18", 20", or 24" as called out on drawings.

#### 3.3 - Load depths

The load depths shall include 2", 4", & 6" as required.

### 4.0 Splices

All straight sections shall be supplied with pre-installed, auto-locking, splices plates, where possible, as per "AB-Cope" brand. Trays design shall allow for a snap together type connection and shall require no nut and bolt assembly.

### 5.0 Fittings

All fittings shall be fabricated in the field as required, per manufacturer's recommendations. Radius of the fittings shall be based on the "minimum bending" radius of the cables being installed.

### 6.0 Accessories

Accessories such as blind ends, dropouts, and barriers, etc... shall be installed as specified on drawings.

### 7.0 Supports

Supports shall include, but are not limited to, center type, trapeze type, wall supports, and floor supports.

#### 7.1 Auto Locking

All supports shall be supplied with an Auto locking feature, requiring no special tools for attachment of the trays.

#### 7.2 Finish

All supports, including threaded rod and associated hardware shall be electro-galvanized coated to ASTM B633 SC1, or ASTM B633 SC3.



# AB-COPE TRAY

# 10

## Cope Tray

cable trays  
with  
return flanges

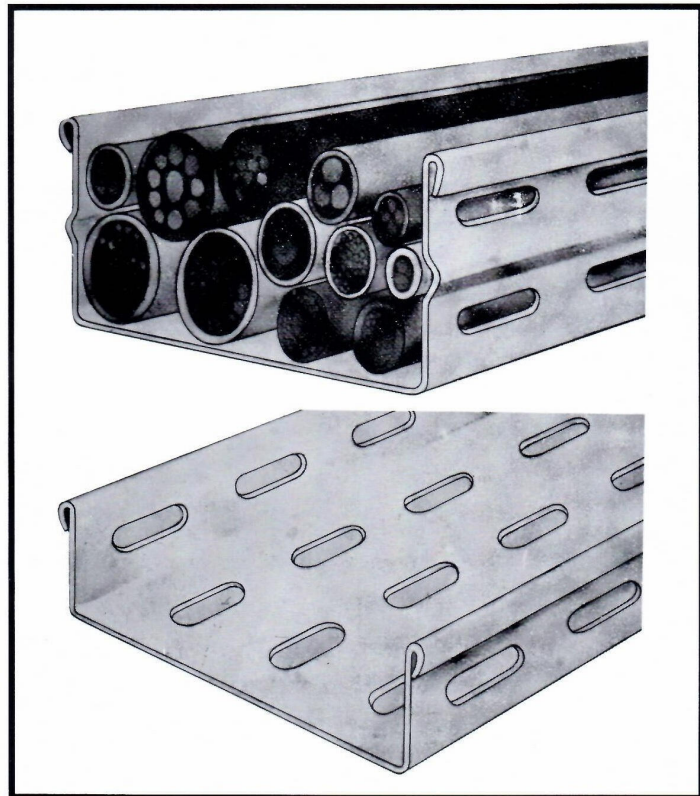

**Cable Tray System for Power, Control,  
Instrumentation Cable & Pneumatic Tubing**

## CONTENTS

### General & Technical Information

|                       |         |
|-----------------------|---------|
| Straight Length ..... | 270-271 |
|-----------------------|---------|

### AB-Cope Tray Fittings

|  |         |
|--|---------|
| Horizontal Elbows, Horizontal Tee, Horizontal Cross, Straight Reducer,<br>Right Left Reducer, Vertical Elbows..... | 272-273 |
|--|---------|

### Connectors & Hardware

|  |         |
|--|---------|
| Universal Curvilinear Connector, Expansion, Mid Span Splice Plate<br>Horiz. and Vert. Adjustable, Reducing and 90° Connector ..... | 274-275 |
|--|---------|

### Covers

|  |     |
|--|-----|
| Covers.....                                | 276 |
| Cover Attachments (Hold down clamps, ..... | 277 |

### Accessories

|  |         |
|--|---------|
| Blind End, Drop Out, Reducing Connector, Box Connector ..... | 278     |
| Cable Recks and Cable Hooks.....                             | 279     |
| Steel Ladder.....  | 280     |
| Tray Supports and Brackets.....                              | 281-282 |
| Tray Load Chart.....   | 183     |

## ROLLED TYPE CABLE TRAYS

### STRAIGHT LENGTH

PART NO. SL

R 25

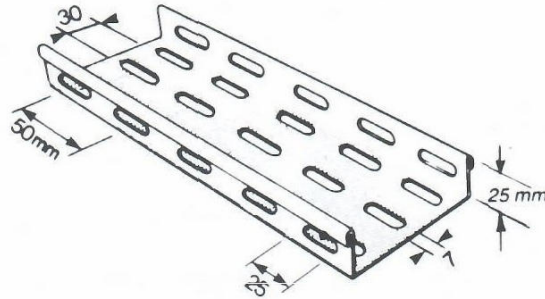

R 55

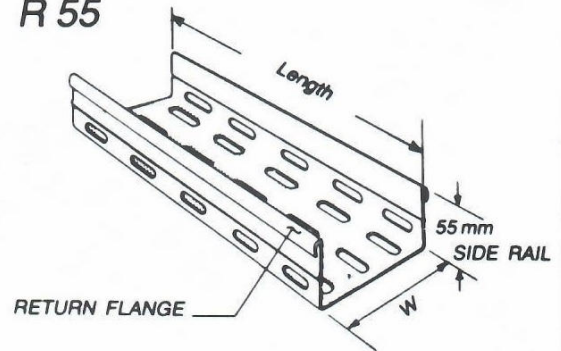

FOR CONNECTORS PLS. TURN TO PAGE 8-6

ORDERING CHART FOR R25 and R55 MAVIL CABLE TRAYS

| SYSTEM  |                   |                 | DESCRIPTION                            |                      |                                     |
|---|-------------------|-----------------|--|----------------------|-------------------------------------|
| MATERIAL THICKNESS  | SIDE RAIL HEIGHT  | MATERIAL FINISH | WIDTH                                  | BASIC PART NO        | LENGTH                              |
| <b>STEEL</b><br>0 - 20 ga.<br>(.9mm)<br>8 - 18 ga.<br>(1.2mm)<br>6 - 16 ga.<br>(1.5mm)<br>4 - 14 ga.<br>(1.9mm) | 1 - (R25 = 25 mm) | 2<br>MILL GALV  | (Consult Head Office for other widths) | SL (STRAIGHT LENGTH) | 2.44 V                              |
|   |                   | 3<br>HDGAF      | 65 mm to 605 mm                        |                      | 2.44 m                              |
| <b>ALUMINUM</b><br>1 - 0.06"<br>(1.5mm)<br>3 - 0.08"<br>(2.0mm)   | 2 - (R55 = 55 mm) | 4<br>ALUM       | 95 mm to 605 mm                        |                      | (Consult Factory for other Lengths) |

NOTE : STD WIDTHS ARE 65, 95, 125, 155, 185, 215, 245, 275, 305, 335, 365, 395, 425, 455, 485, 515, 545, 575, and 605mm.  
 : ALL WIDTHS ARE IN MILLIMETERS. OTHER WIDTHS ARE AVAILABLE.  
 : GALVANIZED PRODUCTS CONFORM TO BRITISH STANDARD.

### ORDER BY CATALOG NO.

EXAMPLE :

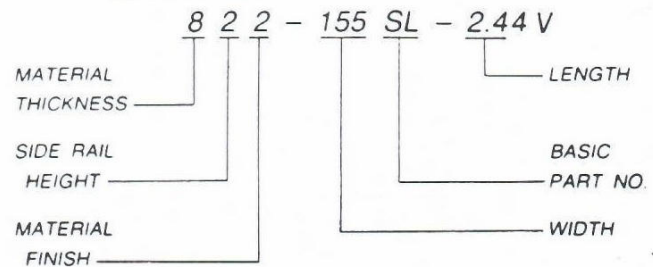

#### ADVANTAGES OF ROLLED TYPE CABLE TRAY

- INCREASE RIGIDITY
- REDUCED RISK OF INJURY FROM SHARP EDGES
- R 55 HAS GROOVED SIDE RAIL FOR STILL MORE RIGIDITY
- THE INCREASED SIDE RAIL HEIGHT AND CARRYING CAPACITY OF R 55 ALLOWS FOR FURTHER CABLE TO BE ADDED LATER.

## C - PROFILE CABLE TRAYS

## PLAIN (P) CABLE TRAYS

### STRAIGHT LENGTH

**PART NO. SL**

C 60 - 60 mm SIDE RAIL HEIGHT  
C 90 - 90 mm SIDE RAIL HEIGHT

\* REINFORCING "C" PROFILE WITH 30 mm INWARD FLANGE AT 90 DEG ANGLE GIVING 50% GREATER RIGIDITY

\* FOR CONNECTORS PLEASE TURN TO PAGE 8-6

### STRAIGHT LENGTH

P 30 - 30 mm SIDE RAIL HEIGHT  
P 60 - 60 mm SIDE RAIL HEIGHT

P ( ) OTHER SIDE RAIL HGT. CAN BE PROVIDED UPON CONSULTATION WITH OUR PRODUCTION DEPT.

**ORDER BY CATALOG NO.**  
EXAMPLE :

4 5 2 - 155 SL - 2.44V

MATERIAL THICKNESS — 4

SIDE RAIL HEIGHT — 5

MATERIAL FINISH — 2

LENGTH — 2.44V

BASIC PART NO — SL

WIDTH — 155

**ORDERING CHART FOR P30, P60, C60, and C90 MAVIL CABLE TRAYS**

| SYSTEM                |                   |                 | DESCRIPTION            |                      |        |
|-----------------------|-------------------|-----------------|------------------------|----------------------|--------|
| MATERIAL THICKNESS    | SIDE RAIL HEIGHT  | MATERIAL FINISH | WIDTH                  | BASIC PART NO        | LENGTH |
| STEEL                 | 3 - (P30 = 30 mm) | 2<br>MILL GALV  | 35 mm<br>to<br>845 mm  | SL (STRAIGHT LENGTH) | 2.44 m |
| 8 - 18 ga<br>(1.2 mm) |                   |                 | 65 mm<br>to<br>785 mm  |                      |        |
| 6 - 16 ga<br>(1.5 mm) | 4 - (P60 = 60 mm) | 3<br>HDGAF      | 155 mm<br>to<br>725 mm |                      | 2.44 V |
| 4 - 14 ga<br>(1.9 mm) | 5 - (C60 = 60 mm) | 4<br>ALUM       | 155 mm<br>to<br>665 mm |                      |        |
| ALUMINUM              | 6 - (C90 = 90 mm) |                 | 155 mm<br>to<br>665 mm |                      |        |
| 1 - 0.06<br>(1.5 mm)  |                   |                 |                        |                      |        |
| 3 - 0.08<br>(2.0 mm)  |                   |                 |                        |                      |        |

NOTE : STD WIDTHS ARE 35, 65, 95, 125, 155, 185, 215, 245, 275, 305, 335, 365, 425, 455, 485, 515, 545, 575, 605, 535, 665, 695 and 725 mm.  
: ALL WIDTHS ARE IN MILLIMETERS.

## FITTINGS For P and R Trays

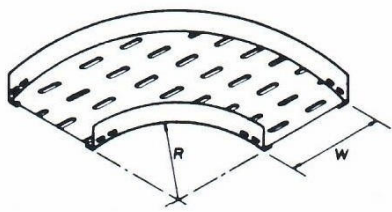
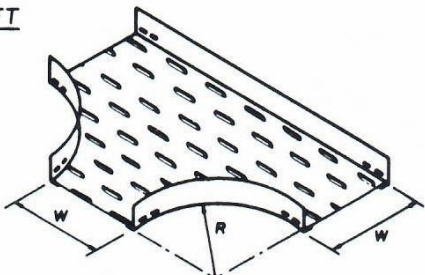
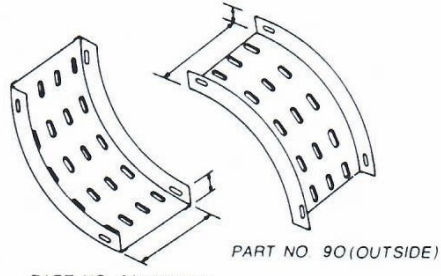
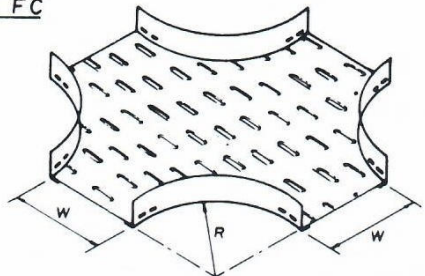
|   |   |
|---|---|
| <p><b>90° HORIZONTAL ELBOW</b><br/>PART NO. 9F</p>                                       | <p><b>FLAT TEE</b><br/>PART NO. FT</p>     |
| <p><b>90° VERTICAL ELBOW</b></p>  <p>PART NO. 91 (INSIDE)<br/>PART NO. 90 (OUTSIDE)</p> | <p><b>FLAT CROSS</b><br/>PART NO. FC</p>  |

**STRAIGHT, LEFT HAND AND RIGHT HAND REDUCER**  
Part No. ST, LH and RH

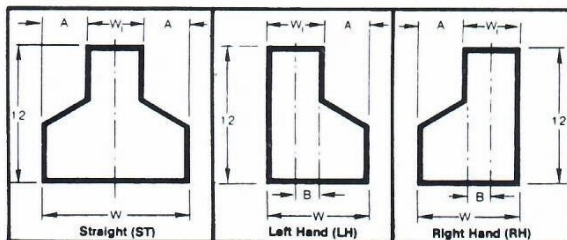
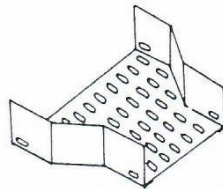

| SYSTEM   |                  |                 | DESCRIPTION                            |                                  |               |
|--|------------------|-----------------|--|----------------------------------|---------------|
| SIDE RAIL THICKNESS  | SIDE RAIL HEIGHT | MATERIAL FINISH | WIDTH                                  | BASIC PART NO                    | RADIUS        |
| STEEL<br>6 - 16 ga.<br>(1.5mm)<br><br>4 - 14 ga.<br>(2.0 mm) | 1-(R25=25mm)     | 2<br>Mill-Galv  | 65mm to 605mm                          | 9F (90 Degrees Horizontal Elbow) | 3<br>(300 mm) |
|  |                  |                 | 95mm to 605mm                          | 6F (60 Degrees Horizontal Elbow) |               |
|  |                  |                 | 35mm to 605mm                          | 4F (45 Degrees Horizontal Elbow) |               |
|  | 3-(P30=30mm)     | 3<br>HDGAF      | 35mm to 845mm                          | 3F (30 Degrees Horizontal Elbow) |               |
|  |                  |                 | 65mm to 785mm                          | FT (Flat Tee)                    |               |
|  |                  |                 | FC (Flat Cross)                        |                                  |               |
| ALUMINUM<br>1 - 060"<br>(1.5mm)<br>3 - 080"<br>(2.0 mm)      | 4-(P60=60mm)     | 4<br>Alum.      | 9I (90 Degrees Inside Vertical Elbow)  | 6<br>(600 mm)                    |               |
|  |                  |                 | 9O (90 Degrees Outside Vertical Elbow) |                                  |               |
|  |                  |                 |  | ST - Straight Reducer            |               |
|  |                  |                 |  | LH - Left hand Reducer           |               |
|  |                  |                 |  | RH - Right Hand Reducer          |               |

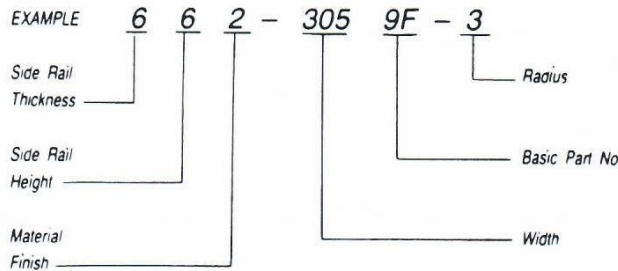

## FITTINGS FOR C - PROFILE TRAYS

**90° HORIZONTAL ELBOW**  
PART NO. 9F

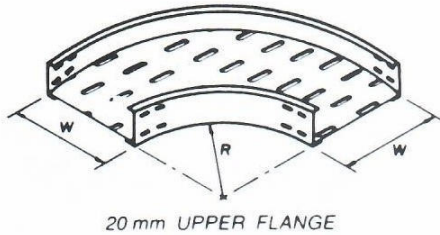

**FLAT TEE**  
PART NO. FT

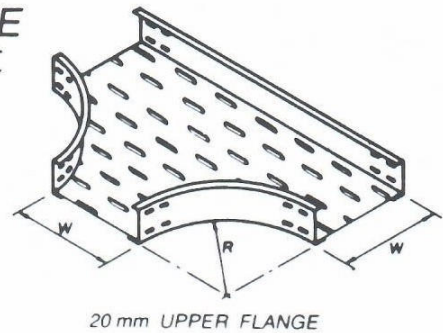

**90° VERTICAL ELBOW**

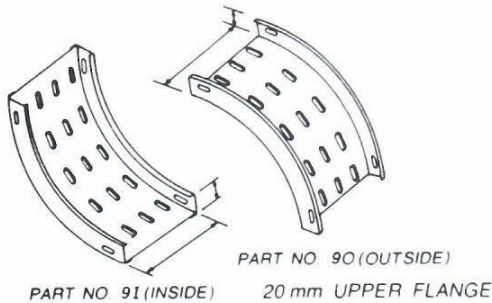

**FLAT CROSS**  
PART NO. FC

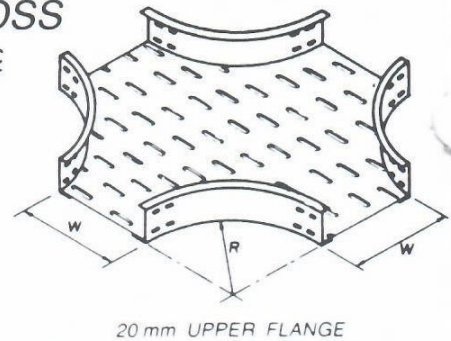

| SYSTEM   |                  |                 | DESCRIPTION                    |   |               |
|--|------------------|-----------------|--------------------------------|---|---------------|
| SIDE RAIL THICKNESS                                    | SIDE RAIL HEIGHT | MATERIAL FINISH | WIDTH                          | BASIC PART NO   | RADIUS        |
| STEEL<br>6 - 16 ga<br>(1.5 mm)                         | 5 - (C60 = 60mm) | 2<br>Mill. Galv | 155 mm<br>to<br>725 mm         | 9F (90 Degrees<br>Horizontal Elbow)<br>6F (60 Degrees<br>Horizontal Elbow)<br>4F (45 Degrees<br>Horizontal Elbow)<br>3F (30 Degrees<br>Horizontal Elbow)<br>FT (Flat Tee) | 3<br>(300mm)  |
| 4 - 14 ga<br>(2.0 mm)                                  | 6 - (C90 = 90mm) | 3<br>HDGAF      | 155 mm<br>to<br>665 mm<br>(mm) | FC (Flat Cross)   | 6<br>(600 mm) |
| ALUMINUM<br>1 -060°<br>(1.5 mm)<br>3 -080°<br>(2.0 mm) |                  | 4<br>Alum.      |                                | 9I (90Degrees Inside )<br>Vertical Elbow )<br>9O (90 Degrees Outside<br>Vertical Elbow )<br>ST - Straight Reducer<br>LH - Left Hand Reducer<br>RH- Right Hand Reducer     |               |

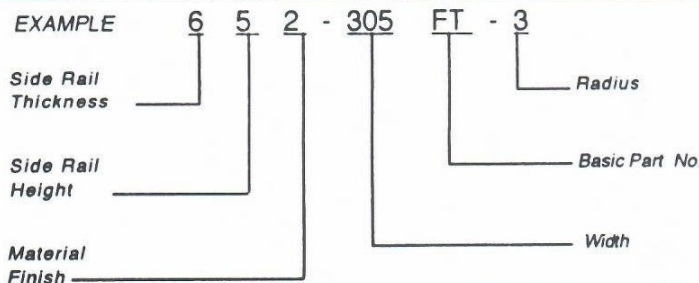

## CONNECTORS FOR R25, R55 and P30

### COUPLER

Part No. CS  
(Sold in Pairs)



Bolts Zinc plated mild steel.

Size 6 x 16 weight .9 kg/100 pcs.  
P/N # - E - 144 - 1/4" x 5/8" Electro Galvanized

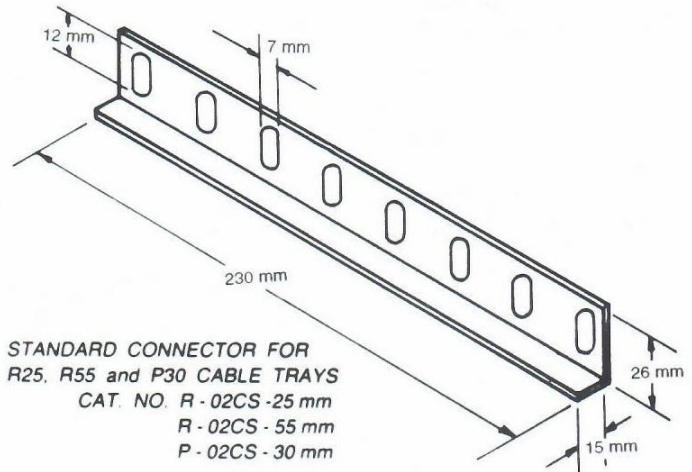

STANDARD CONNECTOR FOR  
R25, R55 and P30 CABLE TRAYS  
CAT. NO. R - 02CS - 25 mm  
R - 02CS - 55 mm  
P - 02CS - 30 mm

### BEND

Part No. CH  
(Sold in Pairs)

HORIZONTAL ADJUSTABLE  
CONNECTOR FOR R 25, R55 and  
P30 CABLE TRAYS

CAT NO R - 02CHB - 25 mm  
R - 02CHB - 55 mm  
P - 02CHB - 30 mm

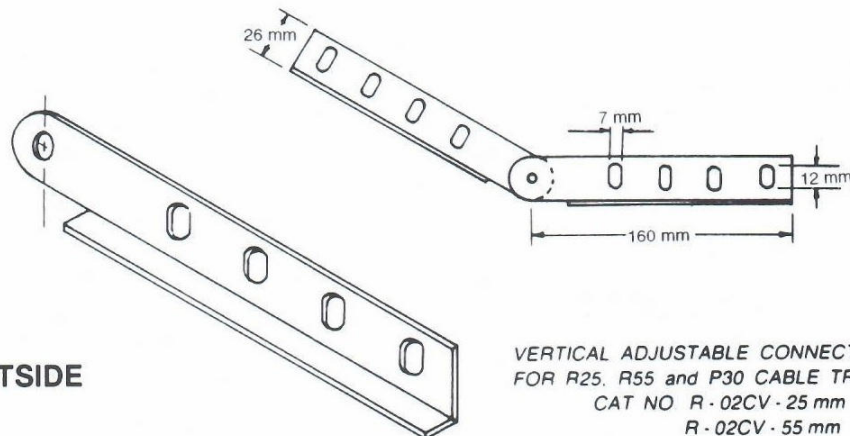
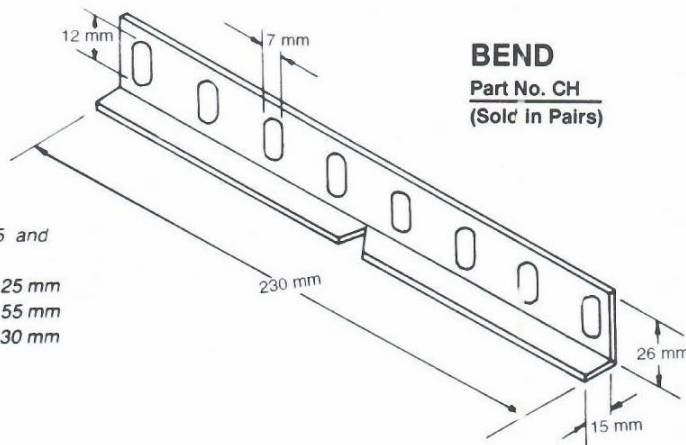

### INSIDE & OUTSIDE RISER

Part No. CV  
(Sold in Pairs)

VERTICAL ADJUSTABLE CONNECTOR  
FOR R25, R55 and P30 CABLE TRAYS

CAT NO R - 02CV - 25 mm  
R - 02CV - 55 mm  
P - 02CV - 30 mm

Note: Hardware shown is supplied with all

## CONNECTORS FOR P60, C60 and C90

### COUPLER

Part No. CS  
(Sold in Pairs)

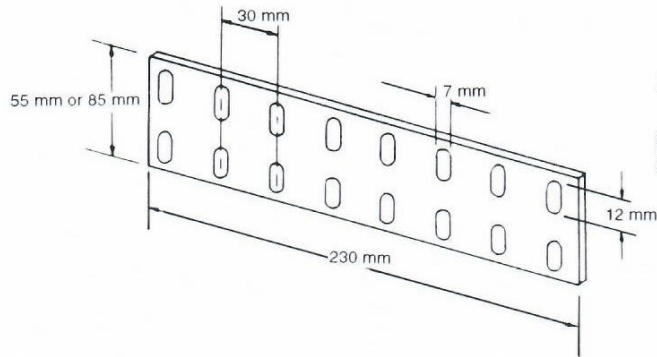

Bolts Zinc plated mild steel.

Size 6 x 16 weight 0.9 kg./100 pcs.  
P/N # - E - 144 - 1/4" x 5/8" Electro Galvanized

Standard Connector for  
P60 and C - Profile Cable Trays  
with 60 mm and 90 mm Side Rail Height  
Cat. No. P - 02 CS - 60 mm  
C - 02 CS - 60 mm  
C - 02 CS - 90 mm

### BEND

Part No. CH  
(Sold in Pairs)

Horizontal Adjustable  
Connector for P 60, C 60  
and C 90 Cable Trays  
Cat. No. P - 02 CH - 60 mm  
C - 02 CH - 60 mm  
C - 02 CH - 90 mm

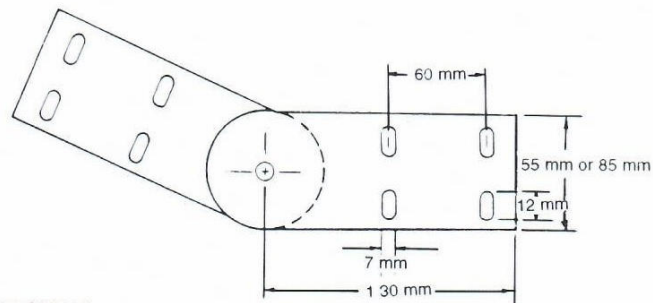
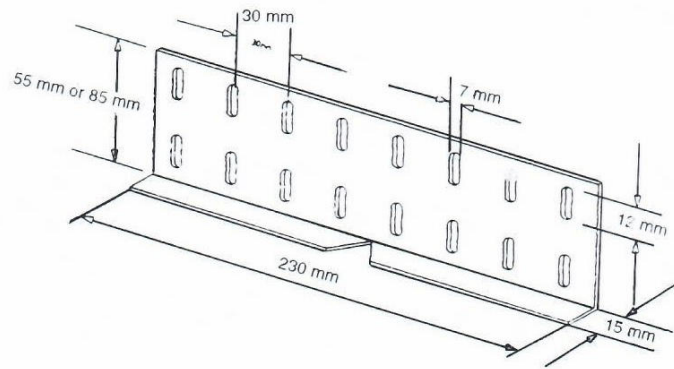

### INSIDE & OUTSIDE

#### RISER

Part No. CV  
(Sold in Pairs)

Vertical Adjustable Connector  
For P60 and C - Profile Cable Tray with  
with 60 mm and 90 mm Side Rail Height  
Cat. No. P - 02 CV - 60 mm  
C - 02 CV - 60 mm  
C - 02 CV - 90 mm

## COVERS

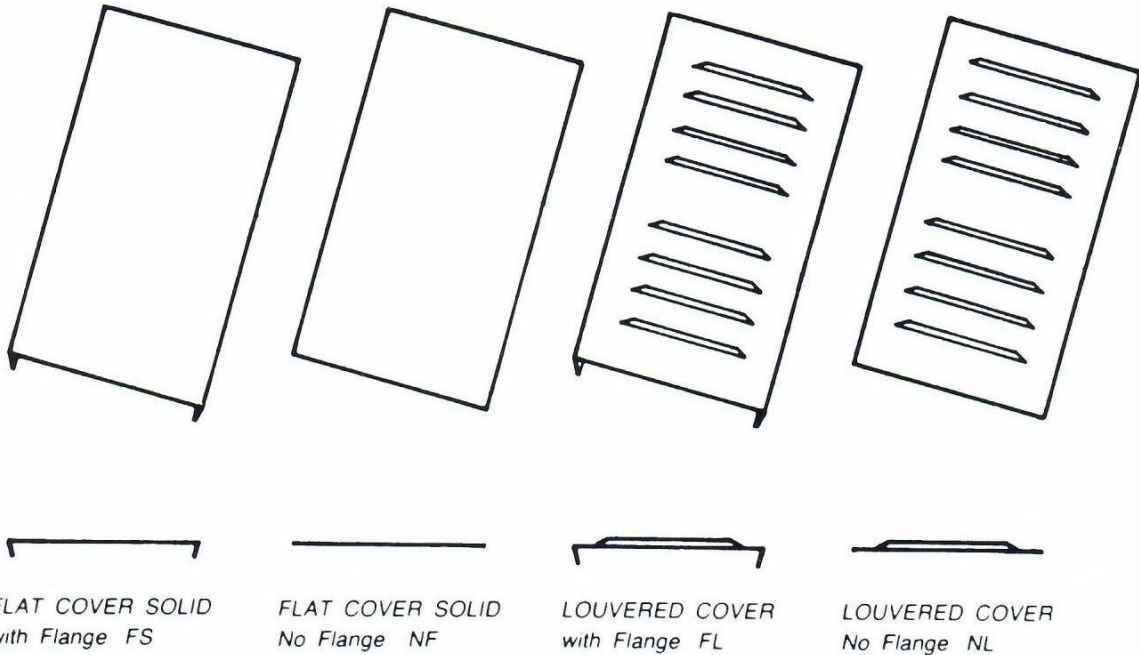

STANDARD THICKNESS: 1.5mm  
 NOTE : Other thickness are available upon request

| COVER TYPE | MATERIAL FINISH            | TRAY WIDTH | BASIC PART NO.                   | LENGTH | TRAY TYPE |
|------------|----------------------------|------------|----------------------------------|--------|-----------|
| FS         | 2<br>Mill · Galv.          | (mm)       | SL - Straight Length             | 2.4 m  | R         |
| NF         | 3<br>Hot Dipped Galvanized |            | 9F (90 Degrees Horizontal Elbow) |        |           |
| FL         |                            |            | 6F (60 Degrees Horizontal Elbow) |        |           |
| NL         |                            |            | 4F (45 Degrees Horizontal Elbow) |        |           |
|            | 4<br>Alum.                 |            | 3F (30 Degrees Horizontal Elbow) |        | P         |
|            |                            |            | FT (Flat Tee)                    |        | C         |
|            |                            |            | FC (Flat Cross)                  |        |           |

EXAMPLE CAT No. FL2-215 SL-2.4-R = is a Flanged-Louvered Cover mill galvanized for 215 mm wide R type Mavil Cable Tray

NOTE : ALL COVERS FOR FITTINGS ARE NON-FLANGED

## COVER ATTACHMENTS

### DOUBLE CLAMP CONNECTOR

PART NO. DC

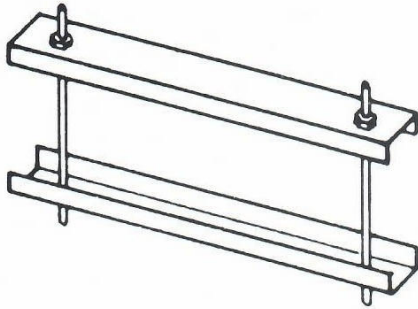

| TRAY TYPE                              | MATERIAL FINISH   | TRAY WIDTH | PART NO. |
|--|-------------------|------------|----------|
| R25<br>R55<br>P30<br>P60<br>C60<br>C90 | 2<br>Mill - Galv. | (mm)       | DC       |
|  | 3<br>HDGAF        |            |          |
|  | 4<br>Alum.        |            | WC       |

### WRAPAROUND CONNECTOR

PART NO. WC

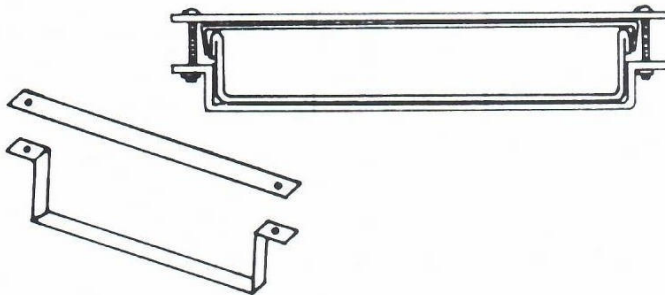

EXAMPLE: CAT. No. R55 2 - 155 DC

Tray Type \_\_\_\_\_ Part No \_\_\_\_\_  
Material Finish \_\_\_\_\_ Width (mm) \_\_\_\_\_

### COVER CLIP

PART NO. CCM

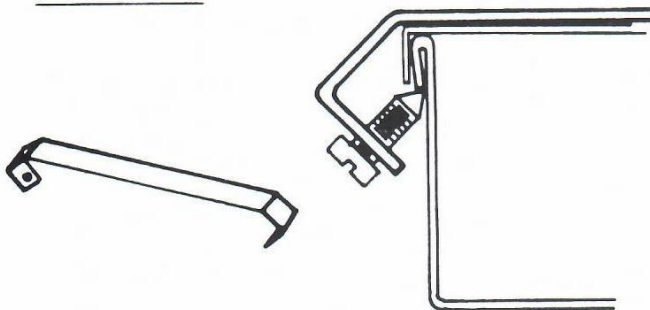

| TRAY TYPE | MATERIAL FINISH   | TRAY WIDTH | PART NO. |
|-----------|-------------------|------------|----------|
| R25       | 2<br>Mill - Galv. | (mm)       | CCM      |
|           | 3<br>HDGAF        |            |          |
| R55       | 4<br>Alum.        |            |          |

NOTE : ORDER BY CAT. NO. SEE ABOVE EXAMPLE

## ACCESSORIES

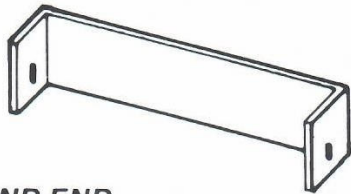

**BLIND END**

PART NO. BE

| TRAY TYPE                              | MATERIAL FINISH                              | TRAY WIDTH | PART NO. |
|--|--|------------|----------|
| R 25, R 55<br>P 30, P 60<br>C 60, C 90 | 2<br>Mill - Galv<br>3<br>HDGAF<br>4<br>Alum. | (mm)       | BE       |

EXAMPLE : CAT. NO. R554 - 335BE

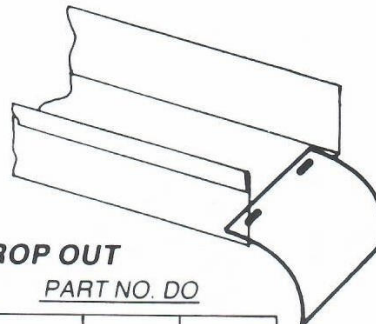

**DROP OUT**

PART NO. DO

| MATERIAL FINISH                              | TRAY WIDTH | PART NO. |
|--|------------|----------|
| 2<br>Mill - Galv<br>3<br>HDGAF<br>4<br>Alum. | (mm)       | DO       |

EXAMPLE : CAT. NO. 3 - 225DO

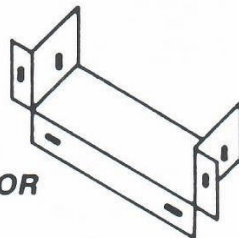

**BOX CONNECTOR**

PART NO. CB

| TRAY TYPE                              | MATERIAL FINISH                               | TRAY WIDTH | PART NO. |
|--|---|------------|----------|
| R 25, R 55<br>P 30, P 60<br>C 60, C 90 | 2<br>Mill - Galv.<br>3<br>HDGAF<br>4<br>Alum. | (mm)       | CB       |

EXAMPLE : CAT. NO. R554 - 425CB

**REDUCING CONNECTOR**

PART NO. CO

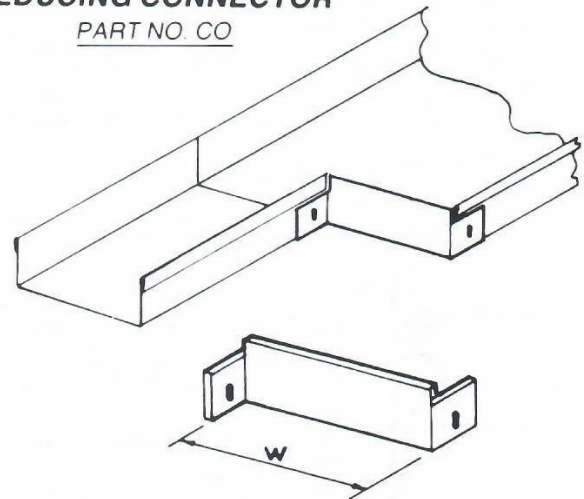

| TRAY TYPE                              | MATERIAL FINISH                              | TRAY WIDTH | PART NO. |
|--|--|------------|----------|
| R 25, R 55<br>P 30, P 60<br>C 60, C 90 | 2<br>Mill - Galv<br>3<br>HDGAF<br>4<br>Alum. | (mm)       | CO       |

EXAMPLE : CAT NO R553 - 215CO

**FISH PLATE / END PLATE / FOR HDGAF SL AND FITTINGS**

PART NO. EP - CONSULT FACTORY FOR DETAILS

**Note :** Hardwares are supplied with above accessories.

## CABLE RACKS and CABLE HOOKS

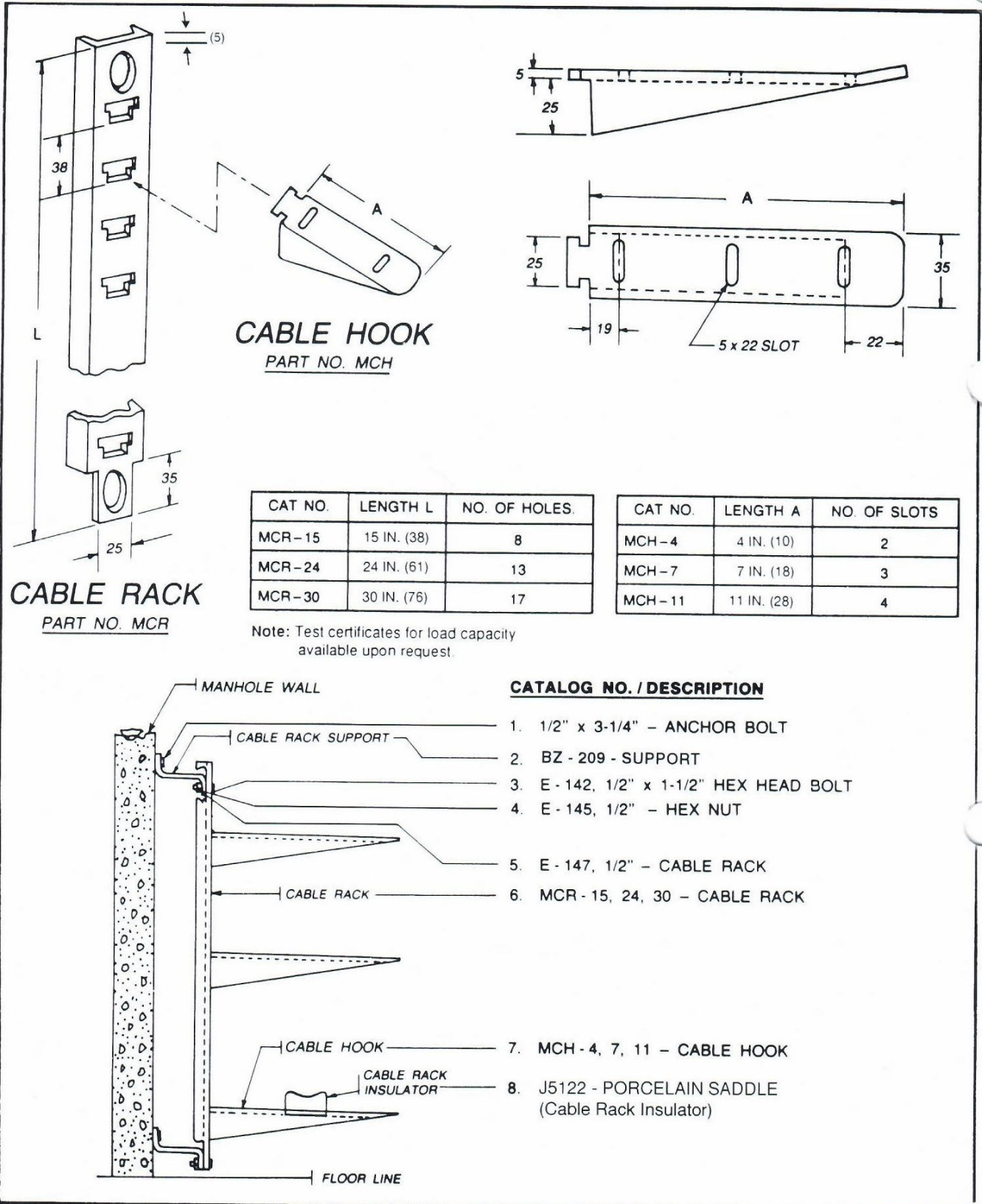

## STEEL LADDER

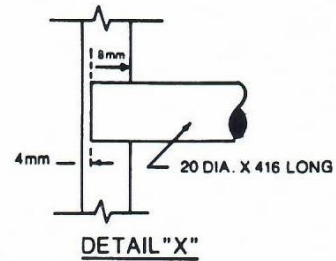
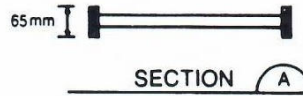
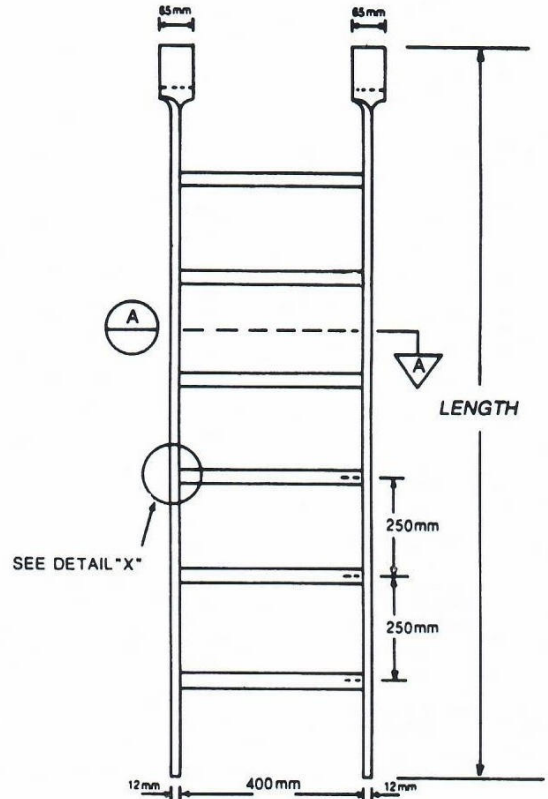
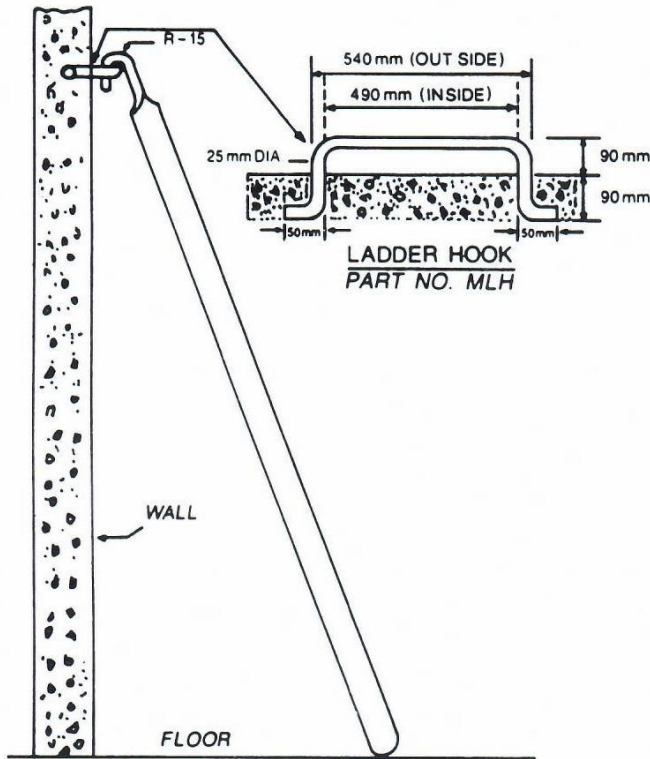

| CAT NO. | LENGTH (mm) | NO. OF STEPS |
|---------|-------------|--------------|
| MSL-150 | 1500        | 5            |
| MSL-175 | 1750        | 6            |
| MSL-200 | 2000        | 7            |
| MSL-225 | 2250        | 8            |
| MSL-250 | 2500        | 9            |
| MSL-275 | 2750        | 10           |
| MSL-300 | 3000        | 11           |
| MSL-325 | 3250        | 12           |

SPECIFICATIONS: Mild Steel And Hot-Dipped Galvanized After Fabrication (ASTM-153)

## SUPPORT FOR CABLE TRAYS

|   |   |            |
|---|---|------------|
| A | - U-564 - S 1/2" (13) Beam Clamp .....                            | (Pg.7-35)  |
| B | - H-104 1/2" (12) Threaded Rod .....                              | (Pg. 7-8)  |
| C | - E-145 1/2" (12) Standard Hex Nut .....                          | (Pg. 7-7)  |
| D | - E-147 1/2" (13) Flat Steel Washer .....                         | (Pg. 7-7)  |
| E | - 9017 Hold Down Clamp .....                                      | (Pg. 3-24) |
| F | - B-1200 H. S. Channel 10' (3mtr) 1-5/8" (41) x 13/16" (21) ..... | (Pg. 7-4)  |
| G | - H-119 1/2" (12) Rod Coupling .....                              | (Pg. 7-9)  |
| H | - A-1200 10' (3mtr) 1-5/8" (41) x 1-5/8" (41) .....               | (Pg. 7-4)  |
| I | - AB-100 1/2" (12) Springless Nut .....                           | (Pg. 7-7)  |
| J | - A-1200 10' (3mtr) Channel 1-5/8" (41) x 1-5/8" (41) .....       | (Pg. 7-4)  |
| K | - S-250 Bracket .....   | (Pg. 7-22) |
| L | - A-100 1/2" (12) Spring Nut .....                                | (Pg. 7-7)  |
| M | - E-142 1/2" (12) x 1/2" (13) Hex Head Cap Screw .....            | (Pg. 7-8)  |
| N | - S-236 Bracket .....   | (Pg. 7-21) |
| O | - S-201 Left or Right 6" (152) - 30" (762) .....                  | (Pg. 7-21) |

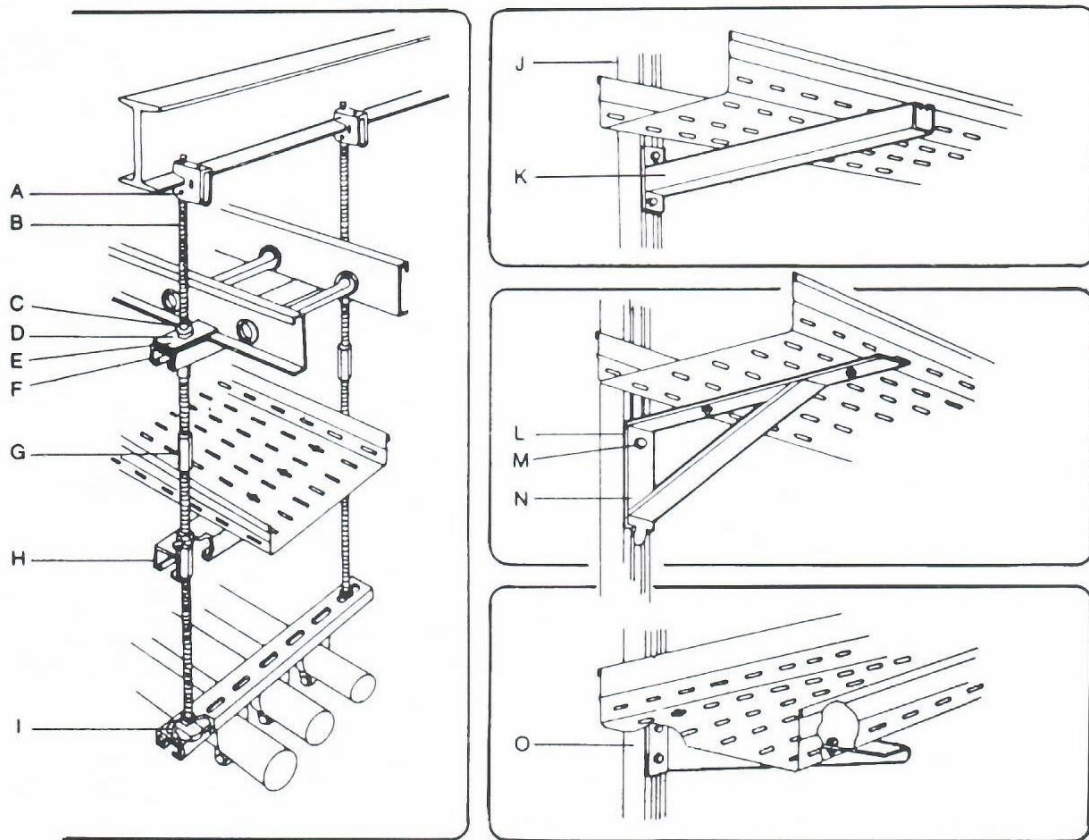

### ABAHSAIN-COPE, SAUDI ARABIA MANUFACTURERS:

1. Cope Cable Ladder — Nema Specifications VE-1 - U.S.
2. Cope Cable Trays — Solid and Perforated - European
3. Saudistrut Support Systems — ASTM Specifications — U.S.

## SUPPORT and BRACKETS (TYPICAL INSTALLATION)

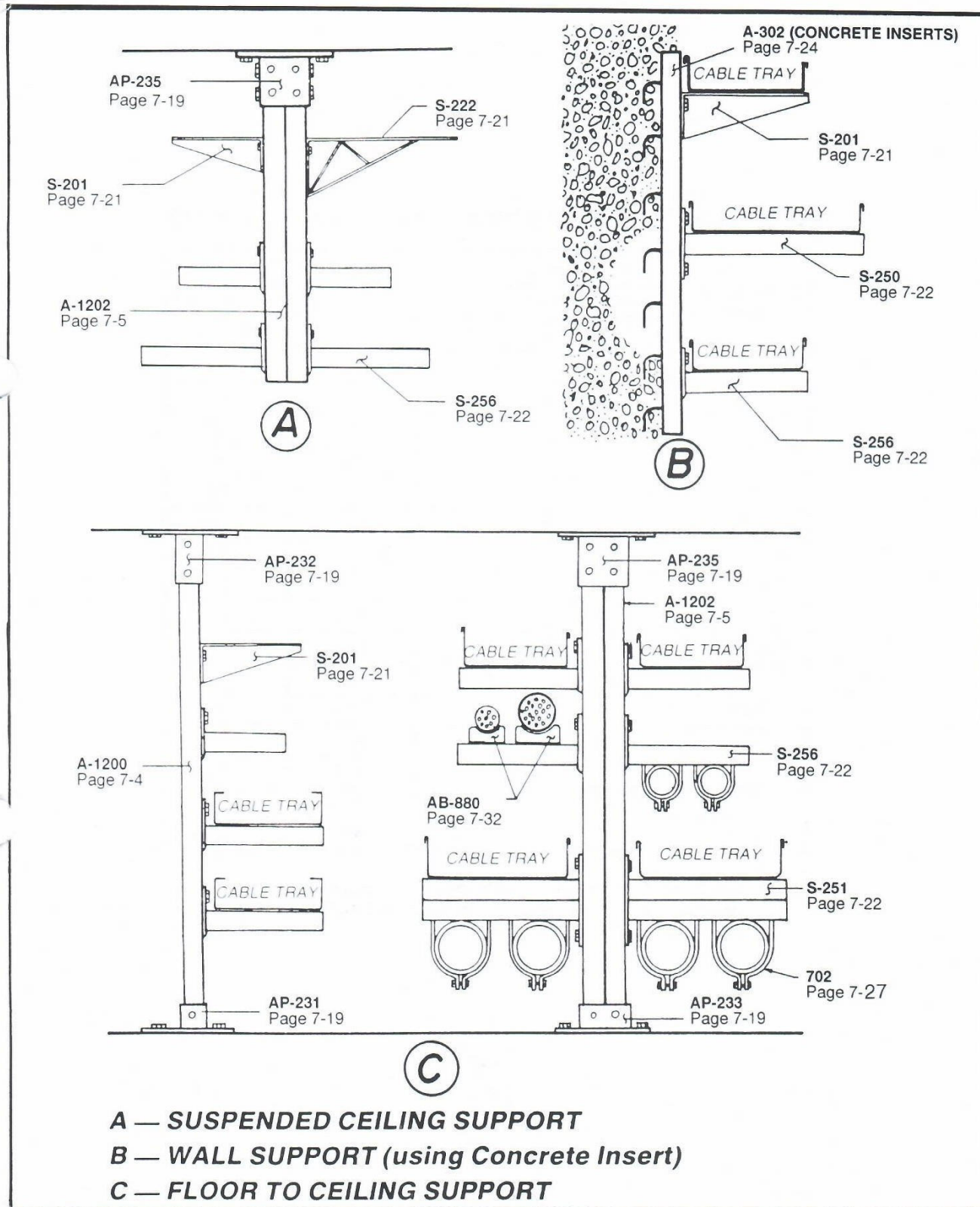

AB-COPE TRAY

## LOAD TABLES (Load in kg./meter run for continuous Spans.)

| Width<br>(mm) | R25                       |       | R55                       |       |
|---------------|---------------------------|-------|---------------------------|-------|
|               | Distance Between Supports |       | Distance Between Supports |       |
|               | 1.5 m                     | 2.0 m | 1.5 m                     | 2.0 m |
| 65            | 28                        | 16    |                           |       |
| 95            | 35                        | 20    | 71                        | 40    |
| 125           | 43                        | 24    | 89                        | 50    |
| 155           | 50                        | 28    | 105                       | 59    |
| 185           | 57                        | 32    | 123                       | 69    |
| 215           | 64                        | 36    | 139                       | 78    |
| 245           | 71                        | 40    | 156                       | 88    |
| 275           | 78                        | 44    | 172                       | 97    |
| 305           | 85                        | 48    | 190                       | 107   |
| 335           | 92                        | 52    | 206                       | 116   |
| 365           | 100                       | 56    | 224                       | 126   |
| 395           | 107                       | 60    | 240                       | 135   |
| 425           | 114                       | 64    | 258                       | 145   |
| 455           | 121                       | 68    | 274                       | 154   |
| 485           | 128                       | 72    | 291                       | 164   |
| 515           |                           |       | 307                       | 173   |

**Note :** This figures assume uniform load distribution along and across the tray. Deflection at mid-span 1/300 (10mm/3m). Safety Factor=2  
Thickness of Cable Tray = 1.5 mm.



# AB-COPE TRUNKING

# 11

## COPE TRUNKING

Solid Cable Trunking System

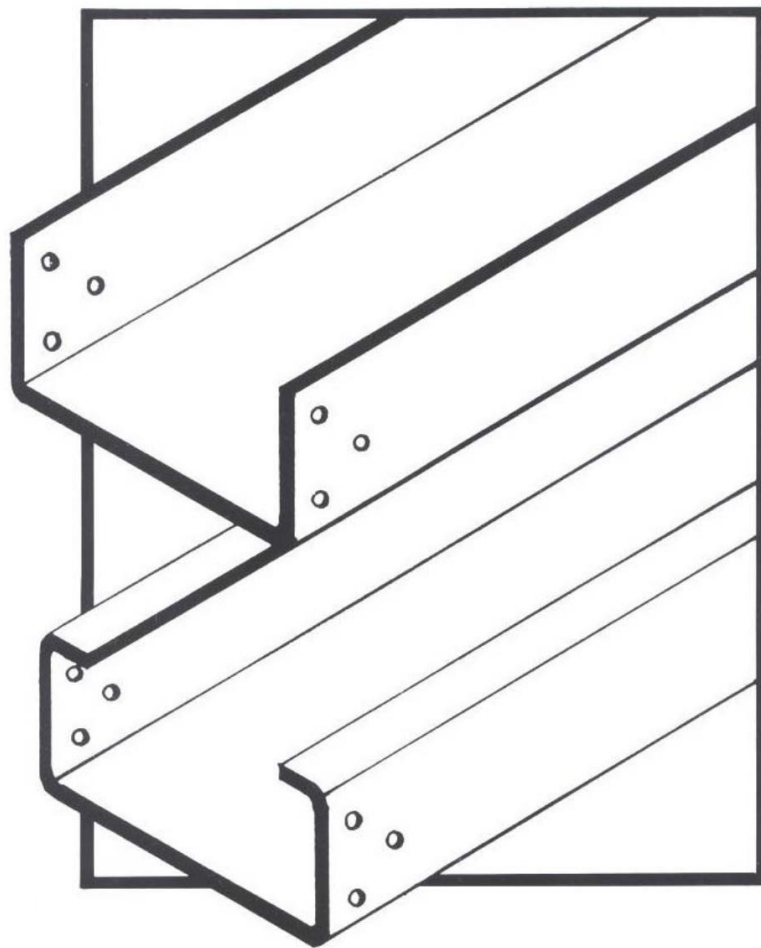

**AB-COPE Trunking System for Power,  
Control, Instrumentation Cable &  
Pneumatic Tubing**

## CONTENTS

### General & Technical Information

|  |         |
|--|---------|
| Content .....  | 286     |
| Straight Length .....  | 288     |
| Fittings .....   | 289-290 |
| Straight Length Cover .....  | 291     |
| Fittings Cover .....   | 292     |
| Barrier Strips .....   | 294     |
| Blind End, Box Connectors .....  | 295     |
| Drop Out, Reducing Connector.....  | 296     |
| Splice Plates, Vertical and Horizontal Adjustable<br>Connectors, Cover Connectors..... | 297     |

## Contents

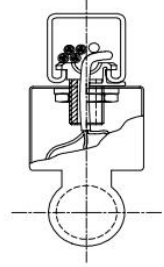

Cope Trunking (Application)

Straight Length

Fittings for PT - Trunking Type, No Flanges

Fitting for CT - Trunking Type with 20 mm, Flanges

Covers

Covers for Fittings

Barrier Strip

Accessories

Connectors

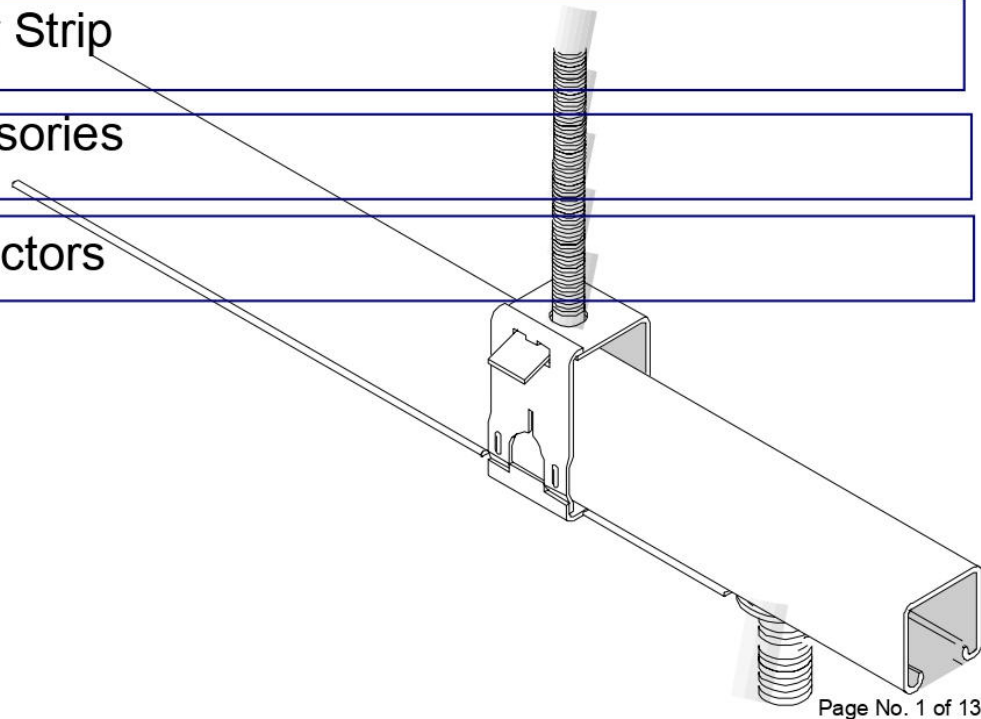

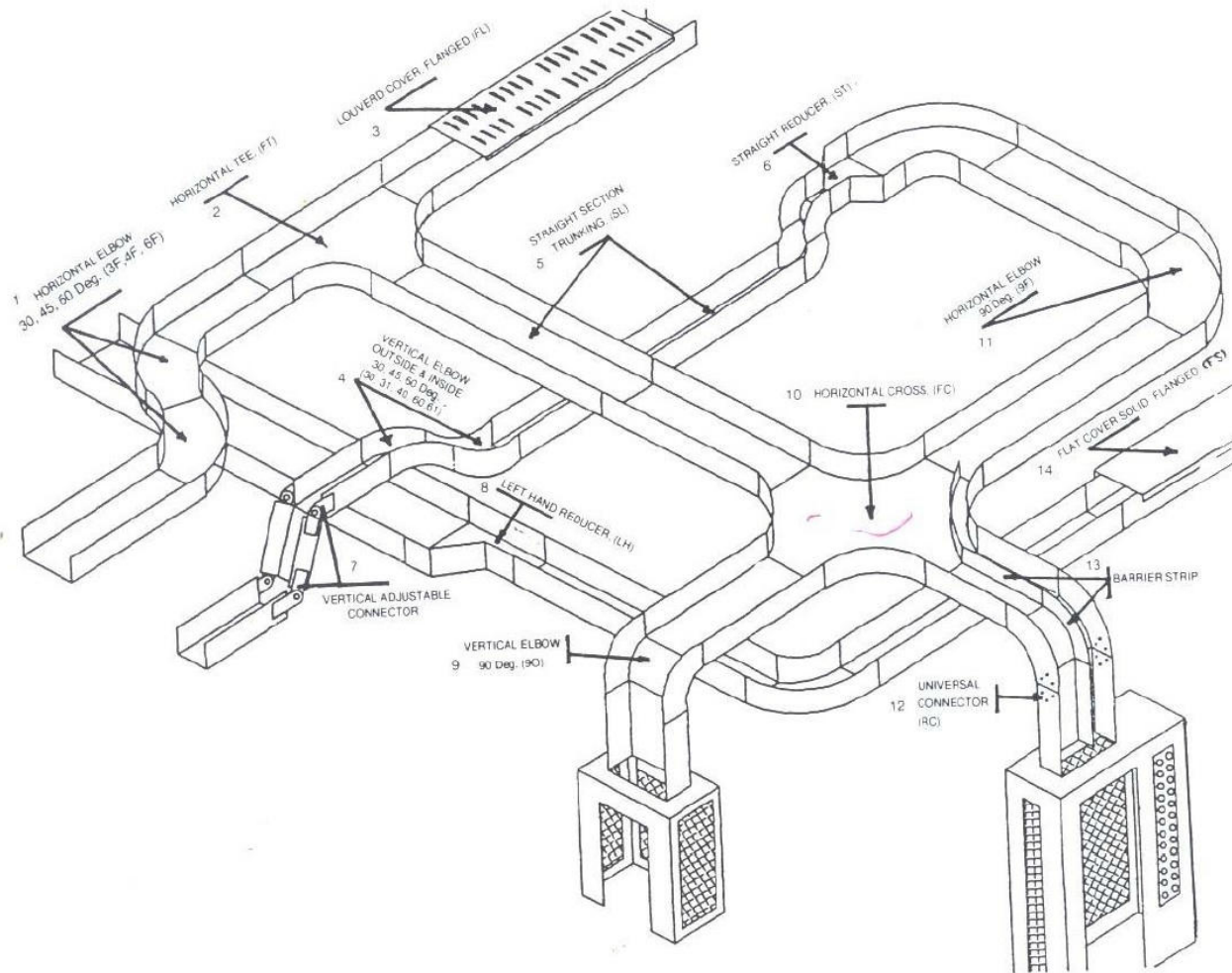

|    |   |     |                               |
|----|---|-----|-------------------------------|
| 1. | Horizontal Elbow<br>30°,45°,60° (3F, 4F, 6F)                          | 8.  | Left Hand Reducer (LH)        |
| 2. | Horizontal Tee (FT)   | 9.  | Vertical Elbow 90° (90)       |
| 3. | Louvered Cover Flanged (FT)   | 10. | Horizontal Cross (FC)         |
| 4. | Vertical Elbow Outside & Inside<br>30°, 45°, 60° (30m 31, 40, 60, 61) | 11. | Horizontal Elbow 90° (9F)     |
| 5. | Straight Section Trunking (SL)  | 12. | Universal Connector (RC)      |
| 6. | Straight Reducer (ST)   | 13. | Barrier Strip                 |
| 7. | Vertical Adjustable Connector   | 14. | Flat Cover Solid Flanged (FS) |

## Straight Length

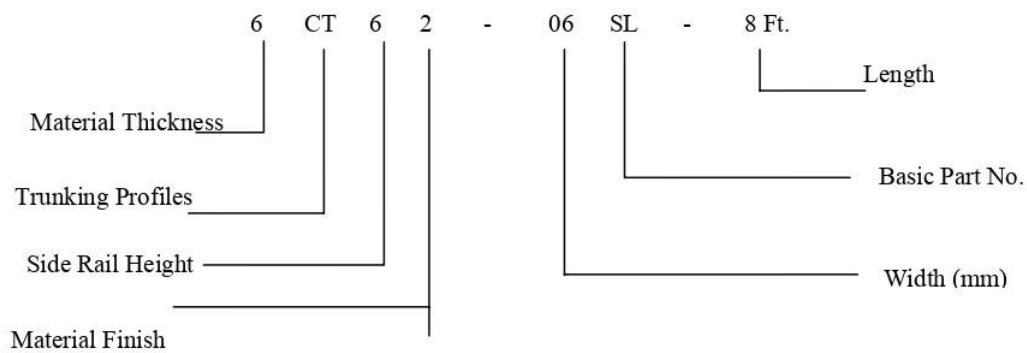
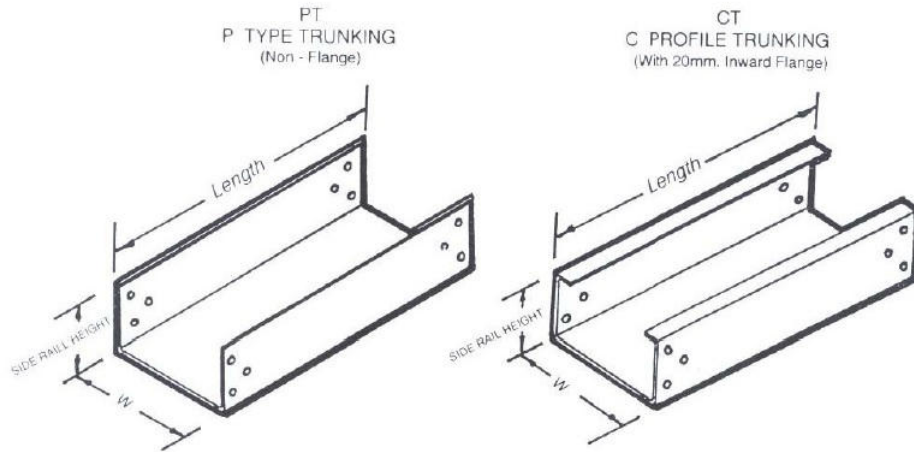

|          | Material Thickness  | Tray Type   | Side Rail Height Inches (mm)        | Material Finish  | Width Inches (mm) | Basic Part No.          | Length Ft. (Meter) |
|----------|---|---|-------------------------------------|--|-------------------|-------------------------|--------------------|
| Steel    | 0-20 ga. (0.9mm)  | PT<br>P Type<br>Trunking<br>(Non-<br>Flange)                  | 2 (50.8)                            | 2 Mill<br>Galvanized                                       | 04 (101.6)        | SL (Straight<br>Length) | 8 (2.44)           |
|          | 8-18 ga. (1.2mm)  |   |                                     |  | 06 (152.4)        |                         |                    |
|          | 6-16 ga. (1.5mm)  |   |                                     |  | 08 (203.2)        |                         |                    |
|          | 4-14 ga. (1.9mm)  |   |                                     |  | 09 (228.6)        |                         |                    |
|          | 2-12 ga. (2.5mm)  |   |                                     |  | 12 (304.8)        |                         |                    |
| Aluminum | 1-0.06" (1.5mm)<br>3-0.08" (2.0mm)<br><br>Also available<br>in Metric sized<br>(Consult<br>factory) | CT<br>C Profile<br>Trunking<br>with 20 mm<br>Inward<br>Flange | 4 (101.6)<br>5 (127.0)<br>6 (152.4) | 3 HDGAF<br>(For 14 ga. &<br>12 ga. Only)<br><br>4 Aluminum | 15 (381.0)        | SL (Straight<br>Length) | 8 (2.44)           |
|          |   |   |                                     |  | 18 (457.2)        |                         |                    |
|          |   |   |                                     |  | 24 (609.6)        |                         |                    |
|          |   |   |                                     |  | 30 (762.0)        |                         |                    |
|          |   |   |                                     |  | 36 (914.4)        |                         |                    |

**Example** 6CT (06)2-06 SL-8 means 16 ga., C profile trunking with 20 mm inward Flange. 6" Side Rail Height, Mill Galvanized Finish, 6" Width, Straight Length and 8 Feet in length.

## Fittings For PT – Trunking Type, No Flanges

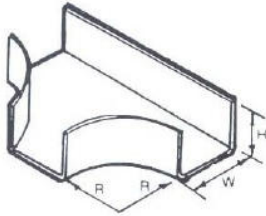

**Horizontal Tee**  
(Part No. FT)

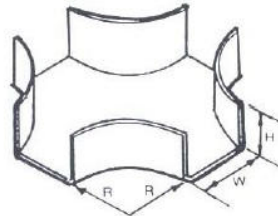

**Horizontal Cross**  
Part No. FC

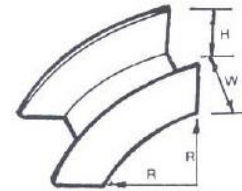

**Vertical Elbow**  
90 Degree Outside  
Part No. 90

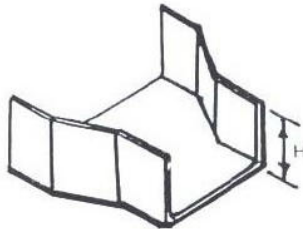

**Straight Reducer**  
Part No. ST

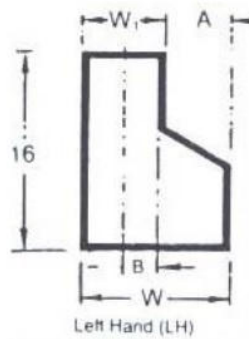

Left Hand (LH)

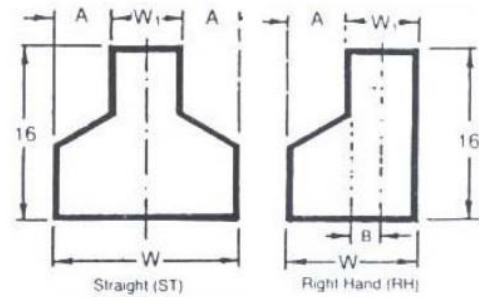

Straight (ST)

Right Hand (RH)

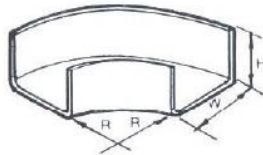

**90 Degree Horizontal Elbow**  
Part NO. 9F

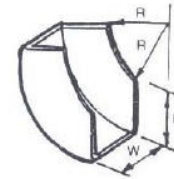

**Vertical Elbow (90 Degree Inside)**  
Part No. 91

| Material Inches (mm) | Material Finish | Width Inches (mm) | Basic Part No.                        | Radius Inches (mm) |
|----------------------|-----------------|-------------------|---------------------------------------|--------------------|
| 03 (76.20)           | 2 Mill Galv.    | 04 (101.6)        | 9F (90 Degree Horizontal Elbow)       | 06 (152.40)        |
|                      |                 | 06 (152.4)        | 6F (60 Degree Horizontal Elbow)       |                    |
|                      |                 | 08 (203.2)        | 4F (45 Degree Horizontal Elbow)       |                    |
| 04 (101.60)          | 3 HDGAF         | 09 (228.6)        | 3F (30 Degree Horizontal Elbow)       | 09 (228.60)        |
|                      |                 | 12 (304.8)        | 91 (90 Degree Inside Vertical Elbow)  |                    |
|                      |                 | 15 (381.0)        | 61 (60 Degree Inside Vertical Elbow)  |                    |
| 05 (127.00)          | 4 ALUM          | 18 (457.2)        | 41 (45 Degree Inside Vertical Elbow)  | 12 (304.80)        |
|                      |                 | 24 (609.6)        | 31 (30 Degree Inside Vertical Elbow)  |                    |
|                      |                 | 30 (762.0)        | 90 (90 Degree Outside Vertical Elbow) |                    |
| 06 (152.40)          |                 | 36 (914.4)        | 60 (60 Degree Inside Vertical Elbow)  | 24 (609.60)        |
|                      |                 |                   | 40 (45 Degree Inside Vertical Elbow)  |                    |
|                      |                 |                   | 30 (30 Degree Inside Vertical Elbow)  |                    |
|                      |                 |                   | FT (Flat Tee)                         | 36 (914.40)        |
|                      |                 |                   | FC ( Flat Cross)                      |                    |
|                      |                 |                   | ST – Straight Reducer                 |                    |
|                      |                 |                   | LH – Left Hand Reducer                |                    |
|                      |                 |                   | RH – Right Hand Reducer               |                    |

Note : Metric equivalent in ( )

## Fittings For CT – Trunking Type With 20 mm Flanges

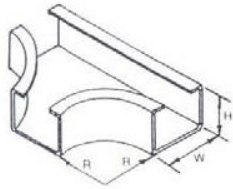

**Horizontal Tee**  
(Part No. FT)

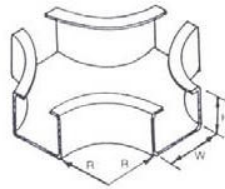

**Horizontal Cross**  
Part No. FC

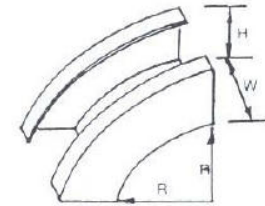

**Vertical Elbow (90 Degree Outside)**  
Part No. 90

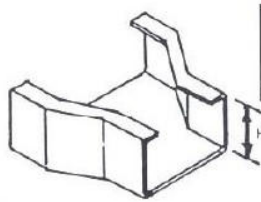

**Straight Reducer**  
Part No. ST

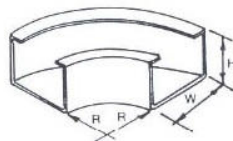
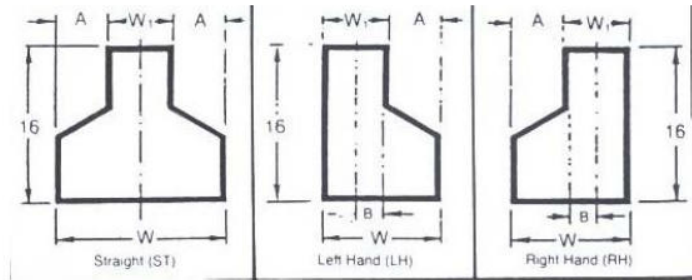

**90 Degree Horizontal Elbow**  
Part NO. 9F

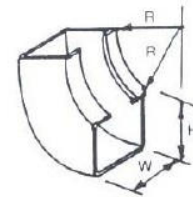

**Vertical Elbow (90 Degree Inside)**  
Part No. 91

| Material Inches (mm) | Material Finish | Width Inches (mm) | Basic Part No.                       | Radius Inches (mm) |                                      |                                       |
|----------------------|-----------------|-------------------|--------------------------------------|--------------------|--------------------------------------|---------------------------------------|
| 03 (76.20)           | 2 Mill Galv.    | 04 (101.6)        | 9F (90 Degree Horizontal Elbow)      | 06 (152.40)        |                                      |                                       |
|                      |                 | 04 (101.60)       | 06 (152.4)                           |                    | 6F (60 Degree Horizontal Elbow)      |                                       |
|                      |                 |                   | 4F (45 Degree Horizontal Elbow)      |                    |                                      |                                       |
|                      |                 |                   | 3F (30 Degree Horizontal Elbow)      |                    |                                      |                                       |
|                      |                 | 05 (127.00)       | 3 HDGAF                              |                    | 08 (203.2)                           | 91 (90 Degree Inside Vertical Elbow)  |
|                      |                 |                   |                                      |                    | 61 (60 Degree Inside Vertical Elbow) |                                       |
|                      |                 | 06 (152.40)       | 4 ALUM                               |                    | 09 (228.6)                           | 41 (45 Degree Inside Vertical Elbow)  |
|                      |                 |                   |                                      |                    | 12 (304.8)                           | 31 (30 Degree Inside Vertical Elbow)  |
|                      |                 |                   |                                      |                    | 15 (381.0)                           | 90 (90 Degree Outside Vertical Elbow) |
|                      |                 |                   |                                      |                    | 18 (457.2)                           | 60 (60 Degree Inside Vertical Elbow)  |
|                      |                 | 24 (609.6)        | 40 (45 Degree Inside Vertical Elbow) |                    |                                      |                                       |
|                      |                 | 30 (762.0)        | 30 (30 Degree Inside Vertical Elbow) |                    |                                      |                                       |
|                      |                 | 36 (914.4)        | FT (Flat Tee)                        |                    |                                      |                                       |
|                      |                 |                   | FC ( Flat Cross)                     |                    |                                      |                                       |
|                      |                 |                   | ST – Straight Reducer                | 36 (914.40)        |                                      |                                       |
|                      |                 |                   | LH – Left Hand Reducer               |                    |                                      |                                       |
|                      |                 |                   | RH – Right Hand Reducer              |                    |                                      |                                       |

Note : Metric equivalent in ( )

## COVERS

**Flat Cover Solid**  
With Flange FS



**Flat Cover Solid**  
Without Flange NF

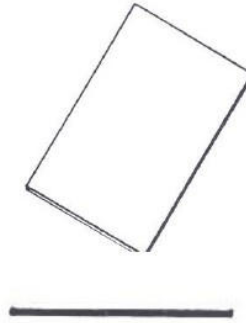

**Louvered Cover**  
Without Flange NL

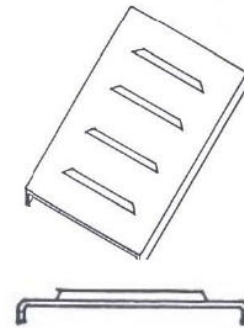

| Cover Type | Material Finish | Width Inches (mm) | Basic Part No.         | Length Ft. (Meter) | Trunking Type |
|------------|-----------------|-------------------|------------------------|--------------------|---------------|
| FS         | 2 Mill Galv.    | 04 (101.6)        | Straigh<br>t<br>Length | 8 (2.44)           | PT<br><br>CT  |
|            |                 | 06 (152.4)        |                        |                    |               |
|            |                 | 08 (203.2)        |                        |                    |               |
|            |                 | 09 (228.6)        |                        |                    |               |
| NL         | 4 ALUM          | 12 (304.8)        |                        |                    |               |
|            |                 | 15 (381.0)        |                        |                    |               |
|            |                 | 18 (457.2)        |                        |                    |               |
|            |                 | 24 (609.6)        |                        |                    |               |
| NL         | 4 ALUM          | 30 (762.0)        |                        |                    |               |
|            |                 | 36 (914.4)        |                        |                    |               |

**Example** FL2-04SL-8-CT means a Flanged – Louvered Cover mill galvanized finished, 04”wide, 8”length and a C type cable trunking.

Note : Metric equivalent in ( )

## Cover For Fitting

### 90 Degree Horizontal Elbow

Part No. 9F

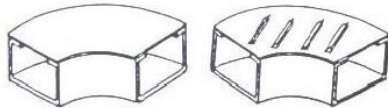

### Vertical Elbow (90 Degree Outside)

Part NO. 90

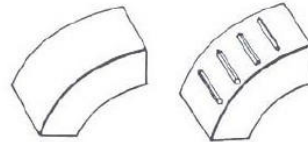

### Horizontal Tee

Part No. FT

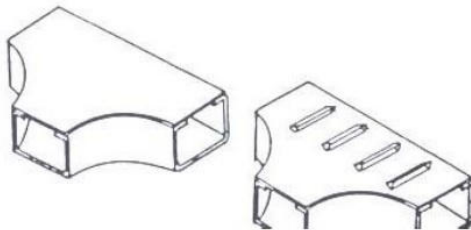

### Vertical Elbow (90 Degree Inside)

Part NO. 91



### Horizontal Cross

Part No. FC

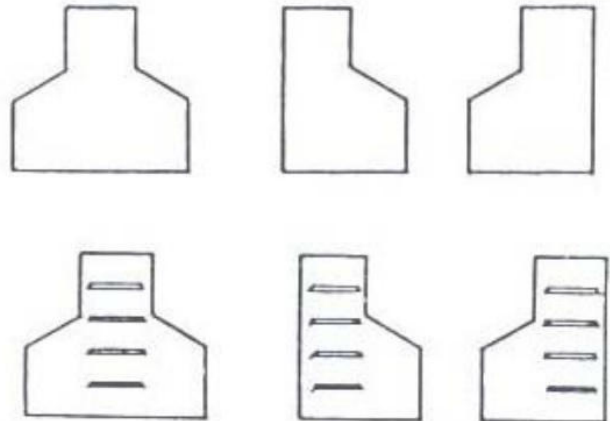
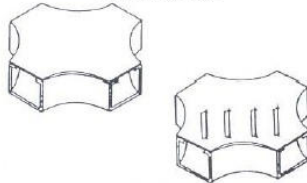

### Straight Reducer

Part NO. ST

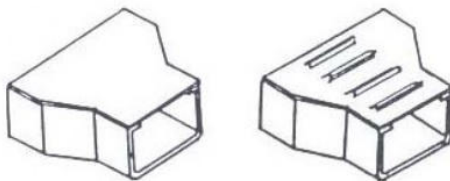

| <i>Cover Type</i> | <i>Material Finish</i> | <i>Width Inches (mm)</i> | <i>Basic Part No.</i>  | <i>Radius Inches (mm)</i>             | <i>Trunking Type</i> |    |
|-------------------|------------------------|--------------------------|--|---------------------------------------|----------------------|----|
| NF                | 2 Mill Galvanized      | 04 (101.6)               | 9F (90 Degree Horizontal Elbow)<br>6F (60 Degree Horizontal Elbow)<br>4F (45 Degree Horizontal Elbow)<br>3F (30 Degree Horizontal Elbow) | 06<br>(152.40)<br>09<br>(228.60)      | PT                   |    |
|                   |                        | 06 (152.4)               | 91 (90 Degree Inside Vertical Elbow)   |                                       |                      |    |
|                   |                        | 08 (203.2)               | 61 (60 Degree Inside Vertical Elbow)   |                                       |                      |    |
|                   |                        | 09 (228.6)               | 41 (45 Degree Inside Vertical Elbow)   |                                       |                      |    |
|                   |                        | 12 (304.8)               | 31 (30 Degree Inside Vertical Elbow)   |                                       |                      |    |
|                   | 4 Aluminum             | NL                       | 15 (381.0)   | 90 (90 Degree Outside Vertical Elbow) | 12<br>(304.80)       | CT |
|                   |                        |                          | 18 (457.2)   | 60 (60 Degree Inside Vertical Elbow)  | 24 (609.60)          |    |
|                   |                        |                          | 24 (609.6)   | 40 (45 Degree Inside Vertical Elbow)  |                      |    |
|                   |                        |                          | 30 (762.0)   | 30 (30 Degree Inside Vertical Elbow)  | 36<br>(914.40)       |    |
|                   |                        |                          | 36 (914.4)   | FT (Flat Tee)<br>FC ( Flat Cross)     |                      |    |
|                   |                        |                          | ST – Straight Reducer<br>LH – Left Hand Reducer<br>RH – Right Hand Reducer   |                                       |                      |    |

**Note :** Fitting Covers are Non-Flange.  
Not Required for Louver  
Metric Equivalent in ( )

## Barrier Strip

### Barrier Strip Straight Section

Part No. SB

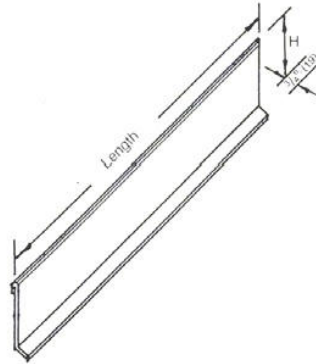
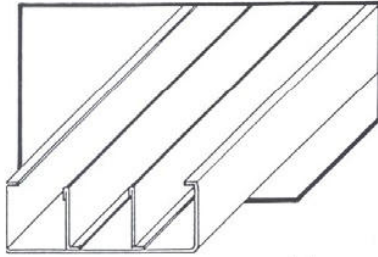

### Barrier Strip Horizontal Fitting

Part No. FB

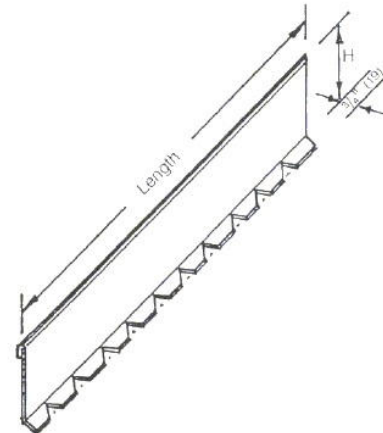
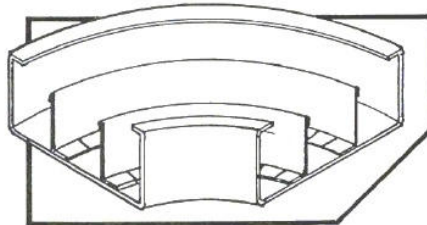

| <i>Height<br/>Inches (mm)</i> | <i>Material Finish</i> | <i>Basic<br/>Part No.</i> | <i>Length<br/>Ft.<br/>(meter)</i> | <i>Tray Type</i> |
|-------------------------------|------------------------|---------------------------|-----------------------------------|------------------|
| 2 (50.8)                      | 2 Mill Galvanized      | 01-SB                     | 8 (2.44)                          | PT               |
| 3 (76.2)                      |                        |                           |                                   | CT               |
| 4 (101.6)                     | 3 HDGAF                | 01-FB                     |                                   |                  |
| 5 (127.0)                     | 4 Aluminum             |                           |                                   |                  |
| 6 (152.4)                     |                        |                           |                                   |                  |

## Accessories

### Blind End

Part No. BE

| Tray Type | Height Inches (mm)  | Material Finish   | Width Inches (mm) | Part No. |            |
|-----------|---|-------------------|-------------------|----------|------------|
| PT<br>CT  | 2 (50.8)<br>3 (76.2)<br>4 (101.6)<br>5 (127.0)<br>6 (152.4) | 2 Mill Galvanized | 04 (101.6)        | BE       |            |
|           |   |                   | 06 (152.4)        |          |            |
|           |   |                   | 08 (203.2)        |          |            |
|           |   |                   | 09 (228.6)        |          |            |
|           |   |                   | 12 (304.8)        |          |            |
|           |   | 3 HDGAF           | 15 (381.0)        |          |            |
|           |   |                   | 4 Aluminum        |          | 18 (457.2) |
|           |   |                   |                   |          | 24 (609.6) |
|           |   |                   |                   |          | 30 (762.0) |
|           |   |                   |                   |          | 36 (914.4) |

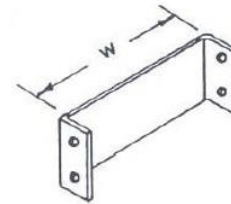

### Box Connector

Part No. CB

| Tray Type | Height Inches (mm)  | Material Finish   | Width Inches (mm) | Part No. |            |
|-----------|---|-------------------|-------------------|----------|------------|
| PT<br>CT  | 2 (50.8)<br>3 (76.2)<br>4 (101.6)<br>5 (127.0)<br>6 (152.4) | 2 Mill Galvanized | 04 (101.6)        | CB       |            |
|           |   |                   | 06 (152.4)        |          |            |
|           |   |                   | 08 (203.2)        |          |            |
|           |   |                   | 09 (228.6)        |          |            |
|           |   |                   | 12 (304.8)        |          |            |
|           |   | 3 HDGAF           | 15 (381.0)        |          |            |
|           |   |                   | 4 Aluminum        |          | 18 (457.2) |
|           |   |                   |                   |          | 24 (609.6) |
|           |   |                   |                   |          | 30 (762.0) |
|           |   |                   |                   |          | 36 (914.4) |

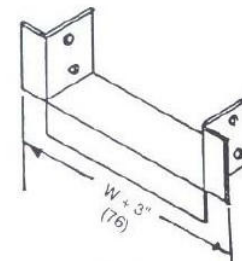

## Reducing Connector Part No. CO

| Tray Type | Height Inches (mm) | Material Finish   | Width Inches (mm) | Part No. |         |            |            |
|-----------|--------------------|-------------------|-------------------|----------|---------|------------|------------|
| PT        | 2 (50.8)           | 2 Mill Galvanized | 04 (101.6)        | CO       |         |            |            |
|           |                    |                   | 06 (152.4)        |          |         |            |            |
|           |                    |                   | 08 (203.2)        |          |         |            |            |
|           |                    |                   | 09 (228.6)        |          |         |            |            |
|           |                    |                   | 12 (304.8)        |          |         |            |            |
|           |                    |                   | CT                |          | 3 HDGAF | 15 (381.0) |            |
|           |                    |                   |                   |          |         | 4 Aluminum | 18 (457.2) |
|           |                    |                   |                   |          |         |            | 24 (609.6) |
|           |                    |                   |                   |          |         |            | 30 (762.0) |
|           |                    |                   |                   |          |         | 36 (914.4) |            |

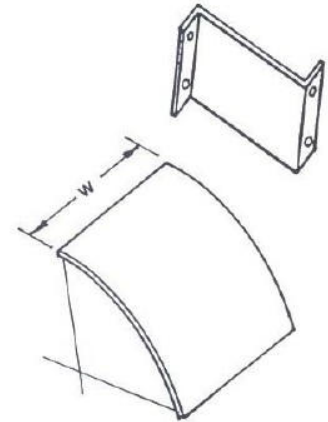

## Drop Out Part No. DO

| Material Finish   | Width Inches (mm) | Part No. |            |            |
|-------------------|-------------------|----------|------------|------------|
| 2 Mill Galvanized | 04 (101.6)        | DO       |            |            |
|                   | 06 (152.4)        |          |            |            |
|                   | 08 (203.2)        |          |            |            |
|                   | 09 (228.6)        |          |            |            |
|                   | 12 (304.8)        |          |            |            |
|                   | 3 HDGAF           |          | 15 (381.0) |            |
|                   |                   |          | 4 Aluminum | 18 (457.2) |
|                   |                   |          |            | 24 (609.6) |
|                   |                   |          |            | 30 (762.0) |
|                   |                   |          | 36 (914.4) |            |

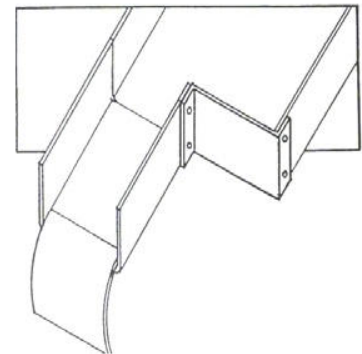

## Connectors

### Universal Connector

Part No. RC (Sold in pairs)

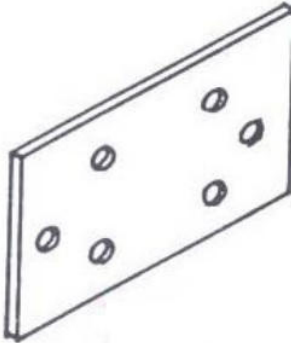

### Expansion Connector

Part No. CE (Sold in pairs)

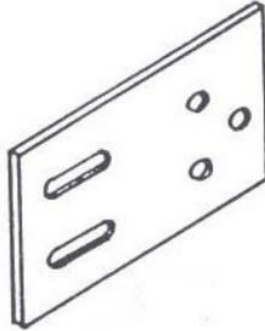

### Vertical Adjustable Connector

Part No. CV (Sold in pairs)

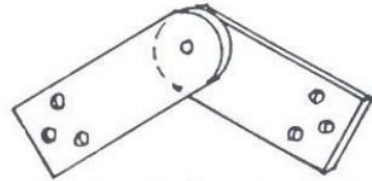

| Height Inches (mm) | Material Finish | Part No. | Tray Type |
|--------------------|-----------------|----------|-----------|
| 3 (76.2)           |                 | 02 RC    | PT        |
| 4 (101.6)          | 3 HDGAF         | 02 CE    | CT        |
| 5 (127.0)          | 4 Aluminum      | 02 CV    |           |
| 6 (152.0)          |                 | 02 CH    |           |

### Horizontal Adjustable Connector

Part No. CH (Sold in pairs – inner & Outer)

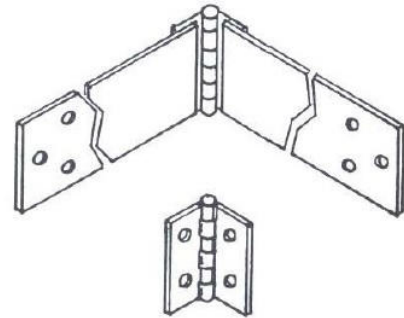

| Tray Type | Material Finish | Width Inches (mm) | Part No. |
|-----------|-----------------|-------------------|----------|
| PT        | 3 HDGAF         | 04 (101.6)        | DC       |
|           |                 | 06 (152.4)        |          |
|           |                 | 08 (203.2)        |          |
|           |                 | 09 (228.6)        |          |
|           |                 | 12 (304.8)        |          |
| CT        | 4 Aluminum      | 15 (381.0)        | WC       |
|           |                 | 18 (457.2)        |          |
|           |                 | 24 (609.6)        |          |
|           |                 | 30 (762.0)        |          |
|           |                 | 36 (914.4)        |          |

### Double Clamp Connector

Part No. (W) DC

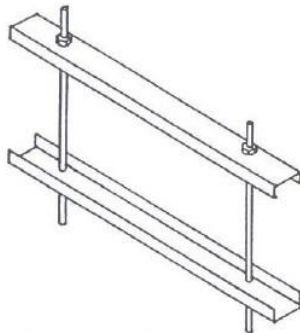

Example : PT2-04DC means P type Mill Galvanized Finished, 04"width, Double Clamp Connector

### Wrap Around Connector

Part No. WC

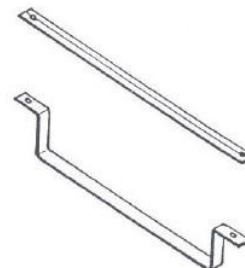

Example : PT2-04WC means P type Mill Galvanized Finished, 04"width, Wrap around Connector



# AB-COPE **UNI-LADDER**

# 12

**UNI LADDER**  
Cable Management



**Cable Ladder Systems**

**Cable Ladder System for Power, Control,  
Instrumentation Cable & Pneumatic Tubing**

## CONTENTS

### General & Technical Information

|                             |         |
|-----------------------------|---------|
| Content.....                | 300     |
| Introduction .....          | 301     |
| Product Specification ..... | 301-303 |
| Ordering Information .....  | 304-306 |
| Straight Length .....       | 307     |

### AB-Cope UNI-Ladder Fittings

|                              |         |
|------------------------------|---------|
| Horizontal Elbows.....       | 308-311 |
| Horizontal Cross .....       | 312     |
| Horizontal Tee .....         | 313     |
| Horizontal Unequal Tee.....  | 314-319 |
| Vertical Insider Riser ..... | 320-323 |
| Vertical Outside Riser ..... | 324-327 |
| Left Right Reducer.....      | 328-329 |
| Straight Reducer.....        | 330     |

### Connectors & Hardware

|  |     |
|--|-----|
| Connectors Straight, Vertical, Horizontal, Clamps, Hold Down Bracket<br>Clips and Reducing Splice..... | 331 |
| Brackets and Blind End .....   | 332 |
| Drop Out, Barrier Strip, Bonding Jumper, Cable tie,<br>Cover and Cover Clip.....                       | 333 |

### Specification Information

|                      |         |
|----------------------|---------|
| Load Test Data ..... | 334-335 |
|----------------------|---------|

## Contents

|                                  |                    |                   |                   |  |
|----------------------------------|--------------------|-------------------|-------------------|--|
| <b>Introduction</b>              |                    |                   |                   |  |
| <b>Product Specification</b>     |                    |                   |                   |  |
| <b>Profiles &amp; Rung Types</b> |                    |                   |                   |  |
| <b>Product Selector</b>          |                    |                   |                   |  |
| <b>Straight Ladder</b>           |                    |                   |                   |  |
| <b>Flat Bend</b>                 |                    |                   |                   |  |
| 30° Flat Bend                    | 45° Flat Bend      | 60° Flat Bend     | 90° Flat Bend     |  |
| <b>Equal Cross</b>               |                    |                   |                   |  |
| <b>Equal Tee</b>                 |                    |                   |                   |  |
| <b>Unequal Tee</b>               |                    |                   |                   |  |
| Unequal Tee 150                  | Unequal Tee 300    | Unequal Tee 450   | Unequal Tee 600   |  |
|                                  | Unequal Tee 750    | Unequal Tee 900   |                   |  |
| <b>Inside Riser</b>              |                    |                   |                   |  |
| 30° Inside Riser                 | 45° Inside Riser   | 60° Inside Riser  | 90° Inside Riser  |  |
| <b>Outside Riser</b>             |                    |                   |                   |  |
| 30° Outside Riser                | 45° Outside Riser  | 60° Outside Riser | 90° Outside Riser |  |
| <b>Reducer</b>                   |                    |                   |                   |  |
| Left Hand Reducer                | Right Hand Reducer | Straight Reducer  |                   |  |
| <b>Accessories</b>               |                    |                   |                   |  |
| <b>Load Test Data Tables</b>     |                    |                   |                   |  |

## Introduction

Unistrut Cable Ladder System represent an innovative generation of user friendly cable management and support products which originated from the specific aspirations and needs of designers, users and installers within the Electrical Industry.

New before has there been a range of Cable Ladders so easy to design and install, yet offering such a diversity of configurations.

With an extensive range of side rails, manufactured in 25mm increments, you can utilize Unistrut Cable Ladder for light commercial and industrial uses, through to high load and offshore applications with total confidence.



Fabrication is from unique cold roll formed side members with cross rungs made from Unistrut slotted Channel, welded alternately channel face up/down, set low in the side members to give maximum working depth and greater options for the securing of cables with cleats and ties.

Unistrut Cable Ladder side members are slotted to allow for side cutting and splicing, without the need for drilling on site.

Both cross rungs and side members feature the familiar Unistrut return edge flange which minimizes the damage to cable sheathing while aiding safety by reducing potential injury to personnel during handling.



AB-Cope have established a quality management system to comply with the requirement of ISO 9001:2000.

## Product Specification

All side members and cross rungs are manufactured from steel material to BS EN 10149-3.

The various components are welded prior to hot dip galvanizing to BS 729.

### Finishes

#### Hot Dip Galvanized

All ladders and accessories are hot dip galvanized after fabrication in accordance with BS 729. The minimum average zinc coating on Unistrut Cable Ladder is as follows:

- Cable Ladder made from 1.5 mm steel -- 335 g/m<sup>2</sup>
- Cable Ladder made from 2.0 mm steel – 460 g/m<sup>2</sup>

#### Stainless Steel

Where required, cable ladder can be manufactured in Grade 304 or 316 SS.

Cable ladder can be chemically pickled and passivated.

#### Other Finishes

Many other finishes may be applied to Unistrut Cable Ladder Systems.

### Widths

Ladders are products with internal widths of 150, 300, 450, 600, 750 and 900 mm.

Additionally, options in 50 mm increments enable European and International design sizes to be supplied.

### Accessories

All side members for Bends, Tees, Risers and Crossovers utilize the side rails used on the straight ladder, intermittently slotted to avoid rungs locations. They are all radiused for strength and aesthetic appeal, while the in-turned edge of the side rail minimizes the damage to cable sheathing.

All accessories are supplied as standard in a choice of radii 300, 450, 600, 750 and 900 mm, or in alternative sizes to order.

### Joining Methods

All Unistrut Cable Ladder can be cut to size on site. The unique rectangular slot configuration eliminates site drilling when splicing, and provides both positive location and the greatest structural benefit.

Splices are supplied in pairs, complete with M10 x 20mm Carriage Bolts, Nuts and Washers.

It is recommended that all fastenings be torque tightened to 55 Nm for optimum performance.

## **Location of Supports**

On continuous spans of Unistrut Cable Ladder, maximum bending moments occur at support and mid span positions. Accessories should always be placed at a support location.

## Product Selector

Unistrut’s adaptable manufacturing process enables infinite combinations of widths, radii and side rail depths, limited only by the constraints of industry applications.

An easy to follow number configuration system is provided. The combination of ladder type, component, width, radius and finish as appropriate, in all that is required.

### Types

- U50 – UniStrut 50mm Deep
- U75 – UniStrut 75mm Deep
- U10 – UniStrut 10mm Deep
- U12 – UniStrut 125mm Deep
- U15 – UniStrut 150mm Deep

### Width (W)

150mm, 300mm, 450mm, 600mm, 750mm, 900mm,. Other widths available to order up to 1500mm wide.

### Finishes (F)

- H – Hot Dip Galvanized
- S – Stainless Steel.
- A – Aluminum
- C – Coated

### Ladders

#### Length

- L3 – 3 Meters
- L6 – 6 Meters

e.g.

| <i>Type</i> | <i>L</i> | <i>W</i> | <i>F</i> |             |
|-------------|----------|----------|----------|-------------|
| U10         | L3       | 450      | H        | → U10L3450H |

### Equal, Unequal Tees & Crosses

- ET – Equal Tee
- UT – Unequal Tee
- EC - Equal Cross

e.g.

| <i>Type</i> | <i>Acc</i> | <i>Through Width</i> | <i>Throat Width</i> | <i>Radius</i> | <i>F</i> |                  |
|-------------|------------|----------------------|---------------------|---------------|----------|------------------|
| U10         | UT         | 600                  | 300                 | 900           | H        | → U10UT60/30/90H |

Please show Width & Radius without last digit.

## Flat Bends & Risers

- FB – Flat Bend
- IR – Inside Riser
- OR – Outside Riser

e.g.

| <i>Type</i> | <i>Acc</i> | <i>W</i> | <i>Degree</i> | <i>Radius</i> | <i>F</i> |                  |
|-------------|------------|----------|---------------|---------------|----------|------------------|
| U10         | IR         | 300      | 60°           | 450           | S        | → U10IR30/60/45S |

Please show Width & Radius without last digit.

## Reducers

- SR – Straight Reducer
- RR – Right Hand Reducer
- LR – Left Hand Reducer

e.g.

| <i>Type</i> | <i>Acc</i> | <i>Wifth From</i> | <i>Reduce to</i> | <i>F</i> |               |
|-------------|------------|-------------------|------------------|----------|---------------|
| U15         | SR         | 750               | 150              | S        | → U15SR75/15S |

Please show Width & Radius without last digit.

## Ladder Profile

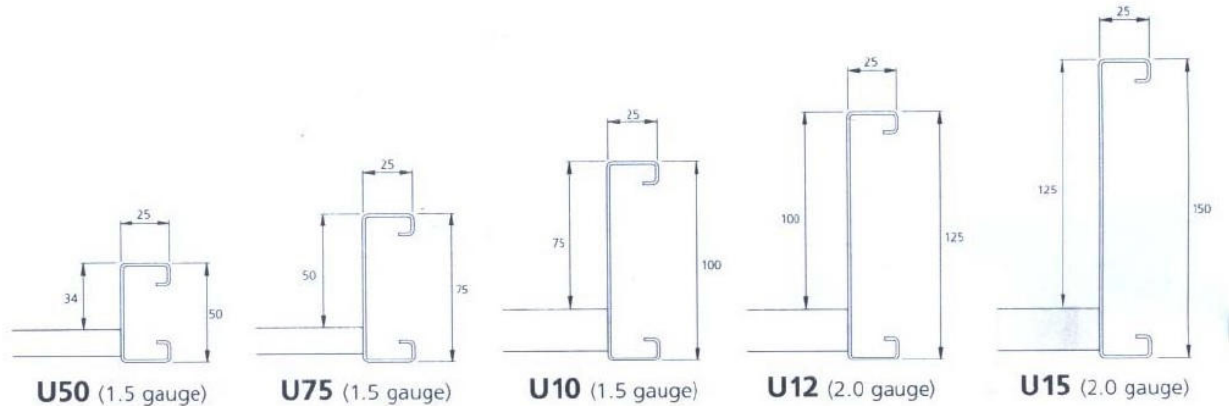

### Range

To ensure suitable Cable Ladders are available to meet designer's and installer's requirements. Unistrut produce a comprehensive range of ladder types. Specified by the height of the side rail, they are available in 50, 75, 100, 125, and 150 mm options.

### Length

Ladders are available in 3 meter lengths from stock or 6 meter to order.

### Working Depth

Shown from tip of rung to top of side rail

## Rung Types

Rungs positioned at 300 mm maximum centers, supplied can be alternately facing up / down. Other options available on request.

Longitudinal slots 28 x 14 at 50 mm centers.

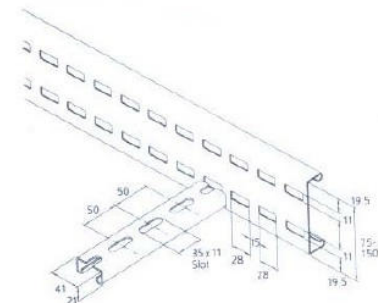

## Straight Ladder

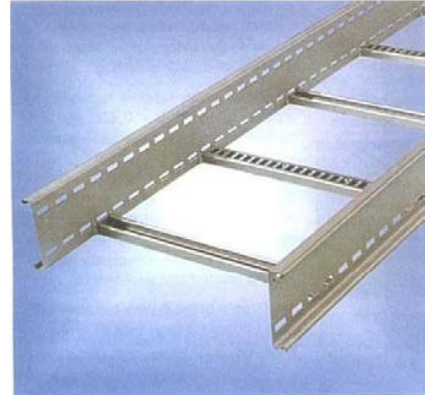
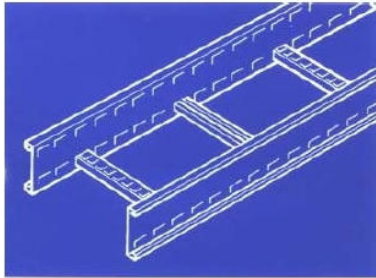

**Depths :** 50, 75, 100, 125 , 150 mm  
**Lengths :** 3m (L3) , 6m (L6)  
**Widths :** 150, 300, 420, 600 , 750 , 900 mm

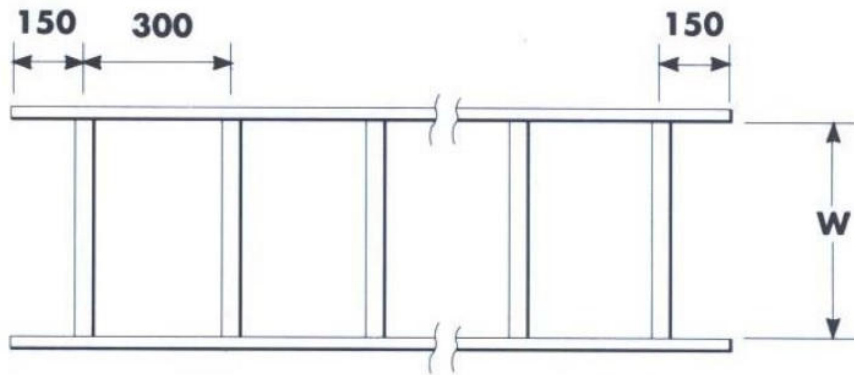

| Part No. | Description      | Dimensions<br>(W) | Weight ((H) Kg |       |       |       |       |
|----------|------------------|-------------------|----------------|-------|-------|-------|-------|
|          |                  |                   | U50            | U75   | U10   | U12   | U15   |
| U**L3150 | LADDER 3 MTR 150 | 150               | 9.54           | 11.53 | 13.48 | 19.97 | 22.53 |
| U**L3300 | LADDER 3 MTR 300 | 300               | 10.61          | 13.22 | 15.14 | 22.10 | 24.66 |
| U**L3450 | LADDER 3 MTR 450 | 450               | 11.68          | 14.91 | 16.83 | 24.23 | 26.79 |
| U**L3600 | LADDER 3 MTR 600 | 600               | 12.75          | 16.60 | 18.52 | 26.36 | 28.92 |
| U**L3750 | LADDER 3 MTR 750 | 750               |                | 18.29 | 20.21 | 28.49 | 31.05 |
| U**L3900 | LADDER 3 MTR 900 | 900               |                | 19.98 | 21.90 | 30.62 | 33.18 |
| U**L6150 | LADDER 6 MTR 150 | 150               | 19.98          | 23.07 | 26.91 | 39.94 | 45.06 |
| U**L6300 | LADDER 6 MTR 300 | 300               | 21.22          | 26.45 | 30.29 | 44.20 | 49.32 |
| U**L6450 | LADDER 6 MTR 450 | 450               | 23.36          | 29.82 | 3.67  | 48.46 | 53.58 |
| U**L6600 | LADDER 6 MTR 600 | 600               | 25.50          | 33.20 | 37.04 | 52.72 | 57.84 |
| U**L6750 | LADDER 6 MTR 750 | 750               |                | 36.58 | 40.42 | 56.98 | 60.10 |
| U**L6900 | LADDER 6 MTR 900 | 900               |                | 39.96 | 43.80 | 61.24 | 66.36 |

\*\* Specify Ladder Type +Weights Shown are based on Hot Dip Galvanized - Reduced Weights for Stainless Steel on Request

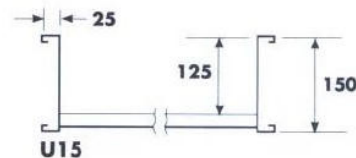
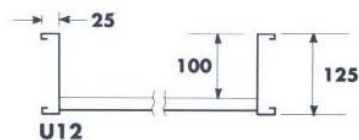
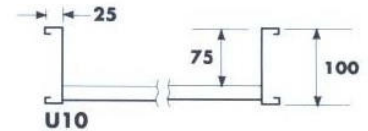
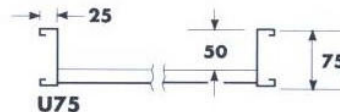
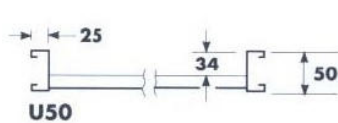

## Flat Bend

**Depths :** 50, 75, 100, 125, 150 mm  
**Widths:** 150, 300, 450, 600, 750, 900 mm  
**Degree:** 30o, 45o, 60o, 90o  
**Radii :** 300, 450, 600, 750, 900 mm

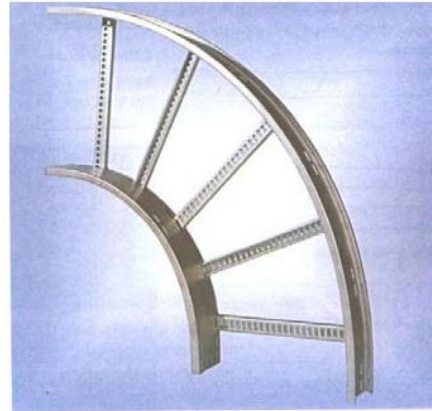

## 30° Flat Bend

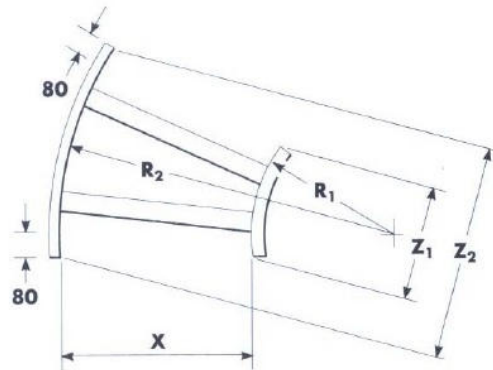
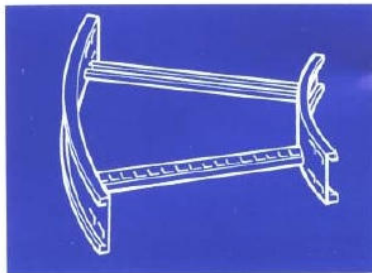

| Part No.      | Description       | Dimensions |     |      |     |      |       | Weight ((Ht) Kg |      |      |      |       |
|---------------|-------------------|------------|-----|------|-----|------|-------|-----------------|------|------|------|-------|
|               |                   | X          | R1  | R2   | Z1  | Z2   | RUNGS | U50             | U75  | U10  | U12  | U15   |
| U**FB15/30/30 | BEND 150W30° 300R | 150        | 300 | 450  | 310 | 387  | 2     | 1.27            | 1.61 | 1.62 | 2.68 | 2.97  |
| U**FB15/30/45 | BEND 150W30° 450R | 150        | 450 | 600  | 387 | 465  | 2     |                 | 1.90 | 2.17 | 3.18 | 3.54  |
| U**FB15/30/60 | BEND 150W30° 600R | 150        | 600 | 750  | 465 | 543  | 2     |                 | 2.18 | 2.51 | 3.68 | 4.11  |
| U**FB15/30/75 | BEND 150W30° 750R | 150        | 750 | 900  | 543 | 620  | 3     |                 | 2.64 | 3.01 | 4.39 | 4.89  |
| U**FB15/30/90 | BEND 150W30° 900R | 150        | 900 | 1050 | 620 | 698  | 3     |                 | 2.92 | 3.34 | 4.89 | 5.46  |
| U**FB30/30/30 | BEND 300W30° 300R | 300        | 300 | 600  | 310 | 465  | 2     | 1.60            | 2.09 | 2.34 | 3.35 | 3.68  |
| U**FB30/30/45 | BEND 300W30° 450R | 300        | 450 | 750  | 387 | 543  | 2     |                 | 2.38 | 2.68 | 3.85 | 4.25  |
| U**FB30/30/60 | BEND 300W30° 600R | 300        | 600 | 900  | 465 | 620  | 2     |                 | 2.66 | 3.01 | 4.35 | 4.82  |
| U**FB30/30/75 | BEND 300W30° 750R | 300        | 750 | 1050 | 543 | 698  | 3     |                 | 3.29 | 3.68 | 5.28 | 5.81  |
| U**FB30/30/90 | BEND 300W30° 900R | 300        | 900 | 1200 | 620 | 776  | 3     |                 | 3.57 | 4.02 | 5.78 | 6.38  |
| U**FB45/30/30 | BEND 450W30° 300R | 450        | 300 | 750  | 310 | 543  | 2     | 1.93            | 2.58 | 2.85 | 4.03 | 4.40  |
| U**FB45/30/45 | BEND 450W30° 450R | 450        | 450 | 900  | 387 | 620  | 2     |                 | 2.86 | 3.18 | 4.53 | 4.96  |
| U**FB45/30/60 | BEND 450W30° 600R | 450        | 600 | 1050 | 465 | 698  | 3     |                 | 3.65 | 4.02 | 5.67 | 6.17  |
| U**FB45/30/75 | BEND 450W30° 750R | 450        | 750 | 1200 | 543 | 776  | 3     |                 | 3.94 | 4.36 | 6.17 | 6.74  |
| U**FB45/30/90 | BEND 450W30° 900R | 450        | 900 | 1350 | 620 | 853  | 3     |                 | 4.22 | 4.69 | 6.67 | 7.30  |
| U**FB60/30/30 | BEND 600W30° 300R | 600        | 300 | 900  | 310 | 620  | 2     | 2.26            | 3.05 | 3.35 | 4.71 | 5.10  |
| U**FB60/30/45 | BEND 600W30° 450R | 600        | 450 | 1050 | 387 | 698  | 2     |                 | 3.34 | 3.69 | 5.21 | 5.67  |
| U**FB60/30/60 | BEND 600W30° 600R | 600        | 600 | 1200 | 465 | 776  | 3     |                 | 4.30 | 4.70 | 6.56 | 7.09  |
| U**FB60/30/75 | BEND 600W30° 750R | 600        | 750 | 1350 | 543 | 853  | 3     |                 | 4.58 | 5.03 | 7.06 | 7.66  |
| U**FB60/30/90 | BEND 600W30° 900R | 600        | 900 | 1500 | 620 | 931  | 3     |                 | 4.87 | 5.36 | 7.56 | 8.23  |
| U**FB75/30/30 | BEND 750W30° 300R | 750        | 300 | 1050 | 310 | 698  | 2     |                 | 3.53 | 3.86 | 5.38 | 5.81  |
| U**FB75/30/45 | BEND 750W30° 450R | 750        | 450 | 1200 | 387 | 776  | 3     |                 | 4.66 | 5.04 | 6.95 | 7.45  |
| U**FB75/30/60 | BEND 750W30° 600R | 750        | 600 | 1350 | 465 | 853  | 3     |                 | 4.95 | 5.37 | 7.45 | 8.01  |
| U**FB75/30/75 | BEND 750W30° 750R | 750        | 750 | 1500 | 543 | 931  | 3     |                 | 5.23 | 5.71 | 7.95 | 8.58  |
| U**FB75/30/90 | BEND 750W30° 900R | 750        | 900 | 1650 | 620 | 1009 | 3     |                 | 5.52 | 6.04 | 8.45 | 9.15  |
| U**FB90/30/30 | BEND 900W30° 300R | 900        | 300 | 1200 | 310 | 776  | 2     |                 | 4.02 | 4.36 | 6.06 | 6.53  |
| U**FB90/30/45 | BEND 900W30° 450R | 900        | 450 | 1350 | 387 | 853  | 3     |                 | 5.31 | 5.71 | 7.84 | 8.37  |
| U**FB90/30/60 | BEND 900W30° 600R | 900        | 600 | 1500 | 465 | 931  | 3     |                 | 5.60 | 6.04 | 8.34 | 8.94  |
| U**FB90/30/75 | BEND 900W30° 750R | 900        | 750 | 1650 | 543 | 1009 | 3     |                 | 5.88 | 6.38 | 8.84 | 9.51  |
| U**FB90/30/90 | BEND 900W30° 900R | 900        | 900 | 1800 | 620 | 1086 | 3     |                 | 6.16 | 6.71 | 9.34 | 10.07 |

\*\* Specify Ladder Type +Weights Shown are based on Hot Dip Galvanized - Reduced Weights for Stainless Steel on Request

## 45° Flat Bend

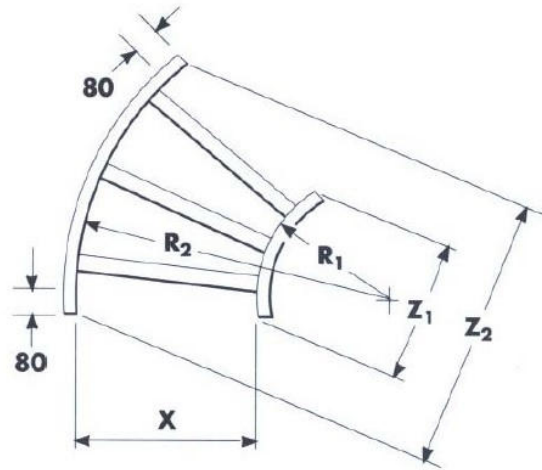
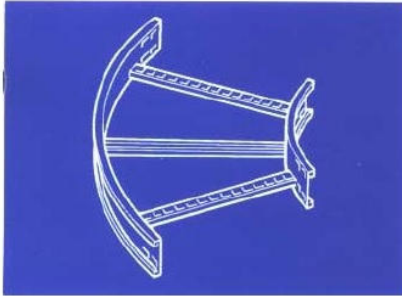

| Part No.      | Description       | Dimensions |     |      |     |      |       | Weight (H <sup>1</sup> ) Kg |      |       |       |       |
|---------------|-------------------|------------|-----|------|-----|------|-------|-----------------------------|------|-------|-------|-------|
|               |                   | X          | R1  | R2   | Z1  | Z2   | RUNGS | U50                         | U75  | U10   | U12   | U15   |
| U**FB15/45/30 | BEND 150W45° 300R | 150        | 300 | 450  | 377 | 492  | 2     | 1.53                        | 1.93 | 2.21  | 3.23  | 3.60  |
| U**FB15/45/45 | BEND 150W45° 450R | 150        | 450 | 600  | 492 | 607  | 3     |                             | 2.52 | 2.87  | 4.19  | 4.66  |
| U**FB15/45/60 | BEND 150W45° 600R | 150        | 600 | 750  | 607 | 721  | 3     |                             | 2.94 | 3.36  | 4.93  | 5.49  |
| U**FB15/45/75 | BEND 150W45° 750R | 150        | 750 | 900  | 721 | 836  | 3     |                             | 3.36 | 3.86  | 5.66  | 6.33  |
| U**FB15/45/90 | BEND 150W45° 900R | 150        | 900 | 1050 | 836 | 951  | 4     |                             | 3.95 | 4.52  | 6.62  | 7.38  |
| U**FB30/45/30 | BEND 300W45° 300R | 300        | 300 | 600  | 377 | 607  | 2     | 1.92                        | 2.48 | 2.79  | 4.03  | 4.45  |
| U**FB30/45/45 | BEND 300W45° 450R | 300        | 450 | 750  | 492 | 721  | 3     |                             | 3.23 | 3.62  | 5.19  | 5.71  |
| U**FB30/45/60 | BEND 300W45° 600R | 300        | 600 | 900  | 607 | 836  | 3     |                             | 3.66 | 4.12  | 5.94  | 6.55  |
| U**FB30/45/75 | BEND 300W45° 750R | 300        | 750 | 1050 | 721 | 951  | 3     |                             | 4.08 | 4.61  | 6.67  | 7.39  |
| U**FB30/45/90 | BEND 300W45° 900R | 300        | 900 | 1200 | 836 | 1066 | 4     |                             | 4.83 | 5.44  | 7.84  | 8.66  |
| U**FB45/45/30 | BEND 450W45° 300R | 450        | 300 | 750  | 377 | 721  | 3     | 2.62                        | 3.53 | 3.88  | 5.46  | 5.93  |
| U**FB45/45/45 | BEND 450W45° 450R | 450        | 450 | 900  | 492 | 836  | 3     |                             | 3.95 | 4.38  | 6.20  | 6.77  |
| U**FB45/45/60 | BEND 450W45° 600R | 450        | 600 | 1050 | 607 | 951  | 3     |                             | 4.37 | 4.87  | 6.95  | 7.61  |
| U**FB45/45/75 | BEND 450W45° 750R | 450        | 750 | 1200 | 721 | 1066 | 4     |                             | 5.30 | 5.87  | 8.32  | 9.09  |
| U**FB45/45/90 | BEND 450W45° 900R | 450        | 900 | 1350 | 836 | 1181 | 4     |                             | 5.72 | 6.37  | 9.07  | 9.93  |
| U**FB60/45/30 | BEND 600W45° 300R | 600        | 300 | 900  | 377 | 836  | 3     | 3.12                        | 4.25 | 4.64  | 6.47  | 6.99  |
| U**FB60/45/45 | BEND 600W45° 450R | 600        | 450 | 1050 | 492 | 951  | 3     |                             | 4.67 | 5.13  | 7.21  | 7.83  |
| U**FB60/45/60 | BEND 600W45° 600R | 600        | 600 | 1200 | 607 | 1066 | 3     |                             | 5.09 | 5.63  | 7.96  | 8.67  |
| U**FB60/45/75 | BEND 600W45° 750R | 600        | 750 | 1350 | 721 | 1181 | 4     |                             | 6.19 | 6.79  | 9.55  | 10.36 |
| U**FB60/45/90 | BEND 600W45° 900R | 600        | 900 | 1500 | 836 | 1295 | 4     |                             | 6.60 | 7.29  | 10.29 | 11.20 |
| U**FB75/45/30 | BEND 750W45° 300R | 750        | 300 | 1050 | 377 | 951  | 3     |                             | 4.97 | 5.39  | 7.48  | 8.05  |
| U**FB75/45/45 | BEND 750W45° 450R | 750        | 450 | 1200 | 492 | 1066 | 3     |                             | 5.39 | 5.89  | 8.22  | 8.89  |
| U**FB75/45/60 | BEND 750W45° 600R | 750        | 600 | 1350 | 607 | 1181 | 4     |                             | 6.65 | 7.23  | 10.03 | 10.80 |
| U**FB75/45/75 | BEND 750W45° 750R | 750        | 750 | 1500 | 721 | 1295 | 4     |                             | 7.07 | 7.72  | 10.77 | 11.63 |
| U**FB75/45/90 | BEND 750W45° 900R | 750        | 900 | 1650 | 836 | 1410 | 4     |                             | 7.49 | 8.21  | 11.51 | 12.47 |
| U**FB90/45/30 | BEND 900W45° 300R | 900        | 300 | 1200 | 377 | 1066 | 3     |                             | 5.68 | 6.15  | 8.49  | 9.11  |
| U**FB90/45/45 | BEND 900W45° 450R | 900        | 450 | 1350 | 492 | 1181 | 3     |                             | 6.10 | 6.64  | 9.23  | 9.95  |
| U**FB90/45/60 | BEND 900W45° 600R | 900        | 600 | 1500 | 607 | 1295 | 4     |                             | 7.54 | 8.15  | 11.25 | 12.06 |
| U**FB90/45/75 | BEND 900W45° 750R | 900        | 750 | 1650 | 721 | 1410 | 4     |                             | 7.96 | 8.64  | 11.99 | 12.90 |
| U**FB90/45/90 | BEND 900W45° 900R | 900        | 900 | 1800 | 836 | 1525 | 5     |                             | 9.39 | 10.15 | 14.01 | 15.02 |

\*\* Specify Ladder Type +Weights Shown are based on Hot Dip Galvanized - Reduced Weights for Stainless Steel on Request

## 60° Flat Bend

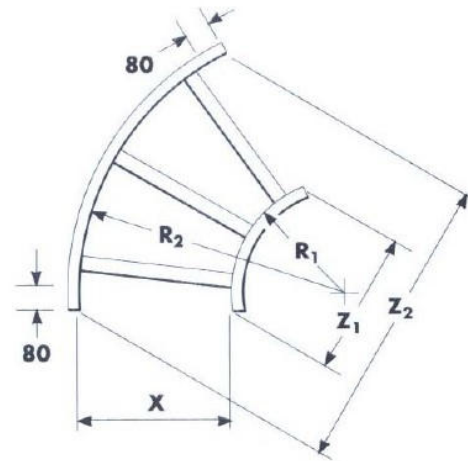
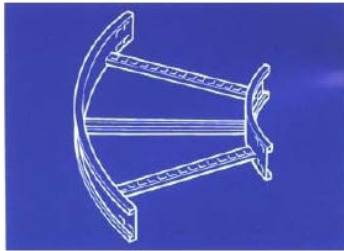

| Part No.      | Description       | Dimension |     |      |      |      |       | Weight (Ht) Kg |           |       |       |       |
|---------------|-------------------|-----------|-----|------|------|------|-------|----------------|-----------|-------|-------|-------|
|               |                   | X         | R1  | R2   | Z1   | Z2   | RUNGS | U50            | U75       | U10   | U12   | U15   |
| U**FB15/60/30 | BEND 150W60° 300R | 150       | 300 | 450  | 439  | 589  | 2     | 1.77           | 2.22      | 2.55  | 3.74  | 4.18  |
| U**FB15/60/45 | BEND 150W60° 450R | 150       | 450 | 600  | 589  | 739  | 3     |                | 2.94      | 3.36  | 4.93  | 5.49  |
| U**FB15/60/60 | BEND 150W60° 600R | 150       | 600 | 750  | 739  | 889  | 3     |                | 3.49      | 4.01  | 5.89  | 6.59  |
| U**FB15/60/75 | BEND 150W60° 750R | 150       | 750 | 900  | 889  | 1039 | 4     |                | 4.21      | 4.82  | 7.07  | 7.90  |
| U**FB15/60/90 | BEND 150W60° 900R | 150       | 900 | 1050 | 1039 | 1189 | 5     |                | 4.92      | 5.64  | 8.26  | 9.21  |
| U**FB30/60/30 | BEND 300W60° 300R | 300       | 300 | 600  | 439  | 739  | 3     | 2.42           | 3.17      | 3.55  | 3.27  | 5.58  |
| U**FB30/60/45 | BEND 300W60° 450R | 300       | 450 | 750  | 589  | 889  | 3     |                | 3.72      | 4.19  | 6.05  | 6.68  |
| U**FB30/60/60 | BEND 300W60° 600R | 300       | 600 | 900  | 739  | 1039 | 4     |                | 4.61      | 5.18  | 7.44  | 8.20  |
| U**FB30/60/75 | BEND 300W60° 750R | 300       | 750 | 1050 | 889  | 1189 | 4     |                | 5.16      | 5.82  | 8.41  | 9.30  |
| U**FB30/60/90 | BEND 300W60° 900R | 300       | 900 | 1200 | 1039 | 1339 | 5     |                | 6.04      | 6.81  | 9.81  | 10.82 |
| U**FB45/60/30 | BEND 450W60° 300R | 450       | 300 | 750  | 439  | 889  | 3     | 2.97           | 3.95      | 4.38  | 6.20  | 6.77  |
| U**FB45/60/45 | BEND 450W60° 450R | 450       | 450 | 900  | 589  | 1039 | 3     |                | 4.50      | 5.02  | 7.17  | 7.87  |
| U**FB45/60/60 | BEND 450W60° 600R | 450       | 600 | 1050 | 739  | 1189 | 4     |                | 5.56      | 6.18  | 8.78  | 9.60  |
| U**FB45/60/75 | BEND 450W60° 750R | 450       | 750 | 1200 | 889  | 1339 | 5     |                | 6.61      | 7.33  | 10.39 | 11.34 |
| U**FB45/60/90 | BEND 450W60° 900R | 450       | 900 | 1350 | 1039 | 1489 | 5     |                | 7.16      | 7.97  | 11.35 | 12.43 |
| U**FB60/60/30 | BEND 600W60° 300R | 600       | 300 | 900  | 439  | 1039 | 3     | 3.53           | 4.73      | 5.21  | 7.33  | 7.96  |
| U**FB60/60/45 | BEND 600W60° 450R | 600       | 450 | 1050 | 589  | 1189 | 4     |                | 5.96      | 6.53  | 9.15  | 9.91  |
| U**FB60/60/60 | BEND 600W60° 600R | 600       | 600 | 1200 | 739  | 1339 | 5     |                | 6.51      | 7.17  | 10.12 | 11.00 |
| U**FB60/60/75 | BEND 600W60° 750R | 600       | 750 | 1350 | 889  | 1489 | 5     |                | 7.73      | 8.49  | 11.94 | 12.95 |
| U**FB60/60/90 | BEND 600W60° 900R | 600       | 900 | 1500 | 1039 | 1639 | 5     |                | 8.28      | 9.14  | 12.90 | 14.05 |
| U**FB75/60/30 | BEND 750W60° 300R | 750       | 300 | 1050 | 439  | 1189 | 3     |                | 5.51      | 6.04  | 8.45  | 9.15  |
| U**FB75/60/45 | BEND 750W60° 450R | 750       | 450 | 1200 | 589  | 1339 | 4     |                | 6.91      | 7.53  | 10.48 | 11.31 |
| U**FB75/60/60 | BEND 750W60° 600R | 750       | 600 | 1350 | 739  | 1489 | 5     |                | 8.30      | 9.02  | 12.52 | 13.47 |
| U**FB75/60/75 | BEND 750W60° 750R | 750       | 750 | 1500 | 889  | 1639 | 5     |                | 8.85      | 9.66  | 13.49 | 14.57 |
| U**FB75/60/90 | BEND 750W60° 900R | 750       | 900 | 1650 | 1039 | 1789 | 5     |                | 9.40      | 10.31 | 14.45 | 15.66 |
| U**FB90/60/30 | BEND 900W60° 300R | 900       | 300 | 1200 | 439  | 1339 | 4     |                | 7.31      | 7.88  | 10.85 | 11.61 |
| U**FB90/60/45 | BEND 900W60° 450R | 900       | 450 | 1350 | 589  | 1489 | 4     |                | 7.86      | 8.52  | 11.82 | 12.71 |
| U**FB90/60/60 | BEND 900W60° 600R | 900       | 600 | 1500 | 739  | 1639 | 5     |                | 9.42      | 10.18 | 14.07 | 15.08 |
| U**FB90/60/75 | BEND 900W60° 750R | 900       | 750 | 1650 | 889  | 1789 | 5     |                | 9.97      | 10.83 | 15.03 | 16.18 |
| U**FB90/60/90 | BEND 900W60° 900R | 900       | 900 | 1800 | 1039 | 1939 | 6     |                | 11.5<br>3 | 12.49 | 17.28 | 18.55 |

\*\* Specify Ladder Type +Weights Shown are based on Hot Dip Galvanized - Reduced Weights for Stainless Steel on Request

## 90° Flat Bend

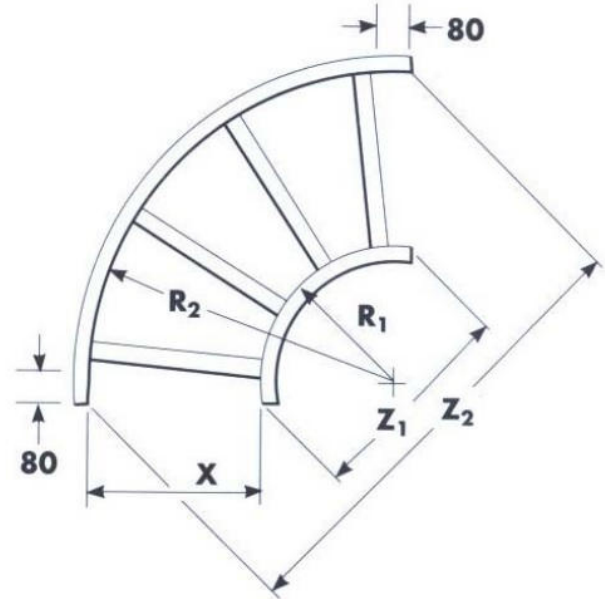
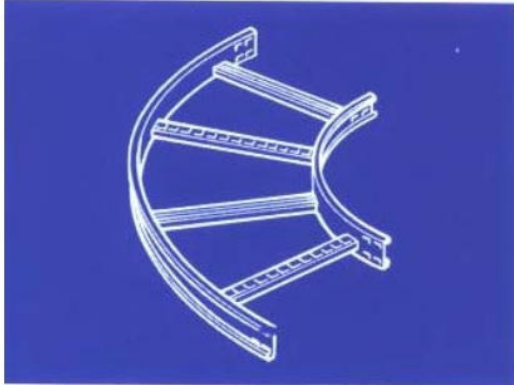

| Part No.      | Description       | Dimension |     |      |      |      |       | Weight ((Ht) Kg |       |       |       |       |
|---------------|-------------------|-----------|-----|------|------|------|-------|-----------------|-------|-------|-------|-------|
|               |                   | X         | R1  | R2   | Z1   | Z2   | RUNGS | U50             | U75   | U10   | U12   | U15   |
| U**FB15/90/30 | BEND 150W90° 300R | 150       | 300 | 450  | 537  | 749  | 3     | 2.27            | 2.86  | 3.27  | 4.79  | 5.34  |
| U**FB15/90/45 | BEND 150W90° 450R | 150       | 450 | 600  | 749  | 961  | 4     |                 | 3.81  | 4.35  | 6.37  | 7.10  |
| U**FB15/90/60 | BEND 150W90° 600R | 150       | 600 | 750  | 961  | 1173 | 5     |                 | 4.75  | 5.44  | 7.95  | 8.86  |
| U**FB15/90/75 | BEND 150W90° 750R | 150       | 750 | 900  | 1173 | 1385 | 5     |                 | 5.53  | 6.35  | 9.32  | 10.41 |
| U**FB15/90/90 | BEND 150W90° 900R | 150       | 900 | 1050 | 1385 | 1598 | 6     |                 | 6.48  | 7.43  | 10.91 | 12.18 |
| U**FB30/90/30 | BEND 300W90° 300R | 300       | 300 | 600  | 537  | 961  | 3     | 2.91            | 3.76  | 4.24  | 6.11  | 6.75  |
| U**FB30/90/45 | BEND 300W90° 450R | 300       | 450 | 750  | 749  | 1173 | 4     |                 | 4.87  | 5.49  | 7.91  | 8.73  |
| U**FB30/90/60 | BEND 300W90° 600R | 300       | 600 | 900  | 961  | 1385 | 5     |                 | 5.99  | 6.74  | 9.70  | 10.70 |
| U**FB30/90/75 | BEND 300W90° 750R | 300       | 750 | 1050 | 1173 | 1598 | 6     |                 | 7.10  | 7.99  | 11.50 | 12.68 |
| U**FB30/90/90 | BEND 300W90° 900R | 300       | 900 | 1200 | 1385 | 1810 | 7     |                 | 8.22  | 9.24  | 13.29 | 14.66 |
| U**FB45/90/30 | BEND 450W90° 300R | 450       | 300 | 750  | 537  | 1173 | 4     | 3.87            | 5.16  | 5.71  | 8.08  | 8.81  |
| U**FB45/90/45 | BEND 450W90° 450R | 450       | 450 | 900  | 749  | 1385 | 5     |                 | 6.44  | 7.13  | 10.08 | 10.99 |
| U**FB45/90/60 | BEND 450W90° 600R | 450       | 600 | 1050 | 961  | 1598 | 5     |                 | 7.22  | 8.04  | 11.45 | 12.55 |
| U**FB45/90/75 | BEND 450W90° 750R | 450       | 750 | 1200 | 1173 | 1810 | 6     |                 | 8.50  | 9.46  | 13.46 | 14.74 |
| U**FB45/90/90 | BEND 450W90° 900R | 450       | 900 | 1350 | 1385 | 2022 | 7     |                 | 9.79  | 10.88 | 15.47 | 16.93 |
| U**FB60/90/30 | BEND 600W90° 300R | 600       | 300 | 900  | 537  | 1385 | 4     | 4.62            | 6.22  | 6.84  | 9.61  | 10.43 |
| U**FB60/90/45 | BEND 600W90° 450R | 600       | 450 | 1050 | 749  | 1598 | 5     |                 | 7.68  | 8.43  | 11.83 | 12.84 |
| U**FB60/90/60 | BEND 600W90° 600R | 600       | 600 | 1200 | 961  | 1810 | 6     |                 | 9.13  | 10.02 | 14.06 | 15.24 |
| U**FB60/90/75 | BEND 600W90° 750R | 600       | 750 | 1350 | 1173 | 2022 | 7     |                 | 10.58 | 11.06 | 16.28 | 17.64 |
| U**FB60/90/90 | BEND 600W90° 900R | 600       | 900 | 1500 | 1385 | 2234 | 8     |                 | 12.03 | 13.19 | 18.50 | 20.04 |
| U**FB75/90/30 | BEND 750W90° 300R | 750       | 300 | 1050 | 537  | 1598 | 5     |                 | 8.13  | 8.82  | 12.22 | 13.13 |
| U**FB75/90/45 | BEND 750W90° 450R | 750       | 450 | 1200 | 749  | 1810 | 5     |                 | 8.91  | 9.73  | 13.59 | 14.68 |
| U**FB75/90/60 | BEND 750W90° 600R | 750       | 600 | 1350 | 961  | 2022 | 6     |                 | 10.53 | 11.49 | 16.02 | 17.29 |
| U**FB75/90/75 | BEND 750W90° 750R | 750       | 750 | 1500 | 1173 | 2234 | 7     |                 | 12.15 | 13.24 | 18.45 | 19.91 |
| U**FB75/90/90 | BEND 750W90° 900R | 750       | 900 | 1650 | 1385 | 2446 | 8     |                 | 13.77 | 15.00 | 20.89 | 22.52 |
| U**FB90/90/30 | BEND 900W90° 300R | 900       | 300 | 1200 | 537  | 1810 | 5     |                 | 9.36  | 10.12 | 13.97 | 14.97 |
| U**FB90/90/45 | BEND 900W90° 450R | 900       | 450 | 1350 | 749  | 2022 | 6     |                 | 11.15 | 12.04 | 16.61 | 17.80 |
| U**FB90/90/60 | BEND 900W90° 600R | 900       | 600 | 1500 | 961  | 2234 | 7     |                 | 12.94 | 13.97 | 14.07 | 20.62 |
| U**FB90/90/75 | BEND 900W90° 750R | 900       | 750 | 1650 | 1173 | 2446 | 8     |                 | 14.73 | 15.89 | 21.91 | 23.45 |
| U**FB90/90/90 | BEND 900W90° 900R | 900       | 900 | 1800 | 1385 | 2658 | 8     |                 | 15.51 | 16.81 | 23.27 | 25.00 |

\*\* Specify Ladder Type +Weights Shown are based on Hot Dip Galvanized - Reduced Weights for Stainless Steel on Request

**Equal Cross**

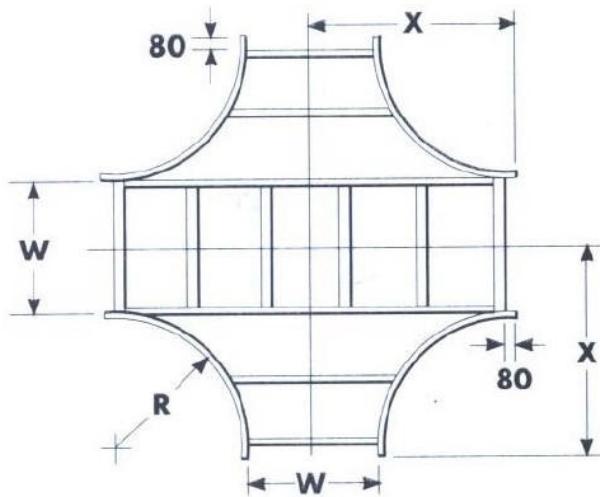
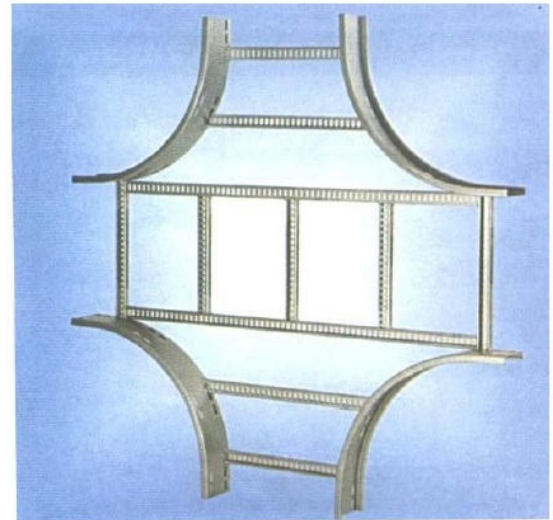
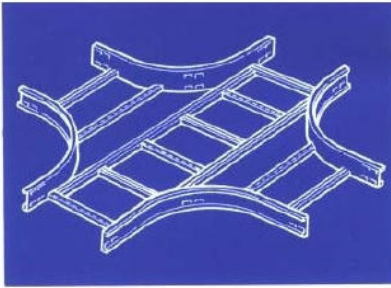

**Depths :** 50, 75, 100, 125, 150 mm  
**Widths :** 150, 300, 450, 600, 750, 900 mm  
**Radii :** 300, 450, 600, 750, 900 mm

| Part No.      | Description        | Dimension |     |      | Weight (H) Kg |       |       |       |       |
|---------------|--------------------|-----------|-----|------|---------------|-------|-------|-------|-------|
|               |                    | W         | R   | X    | U50           | U75   | U10   | U12   | U15   |
| U**EC15/15/30 | 4 WAY 150-150 300R | 150       | 300 | 445  | 5.26          | 6.80  | 7.60  | 10.88 | 11.95 |
| U**EC15/15/45 | 4 WAY 150-150 450R | 150       | 450 | 605  |               | 9.28  | 10.38 | 14.87 | 16.34 |
| U**EC15/15/60 | 4 WAY 150-150 600R | 150       | 600 | 755  |               | 12.55 | 13.96 | 19.86 | 21.73 |
| U**EC15/15/75 | 4 WAY 150-150 750R | 150       | 750 | 905  |               | 15.12 | 16.83 | 23.97 | 26.24 |
| U**EC15/15/90 | 4 WAY 150-150 900R | 150       | 900 | 1055 |               | 17.69 | 19.70 | 28.07 | 30.75 |
| U**EC30/30/30 | 4 WAY 300-300 300R | 300       | 300 | 530  | 6.18          | 8.23  | 9.03  | 12.68 | 13.75 |
| U**EC30/30/45 | 4 WAY 300-300 450R | 300       | 450 | 680  |               | 10.63 | 11.73 | 16.57 | 18.04 |
| U**EC30/30/60 | 4 WAY 300-300 600R | 300       | 600 | 830  |               | 14.41 | 15.82 | 22.20 | 24.08 |
| U**EC30/30/75 | 4 WAY 300-300 750R | 300       | 750 | 980  |               | 17.15 | 18.86 | 26.52 | 28.80 |
| U**EC30/30/90 | 4 WAY 300-300 900R | 300       | 900 | 1130 |               | 19.88 | 21.89 | 30.84 | 33.52 |
| U**EC45/45/30 | 4 WAY 450-450 300R | 450       | 300 | 605  | 7.04          | 9.58  | 10.38 | 14.38 | 15.45 |
| U**EC45/45/45 | 4 WAY 450-450 450R | 450       | 450 | 755  |               | 12.39 | 13.50 | 18.80 | 20.27 |
| U**EC45/45/60 | 4 WAY 450-450 600R | 450       | 600 | 905  |               | 16.68 | 18.09 | 25.07 | 26.94 |
| U**EC45/45/75 | 4 WAY 450-450 750R | 450       | 750 | 1055 |               | 19.59 | 21.30 | 29.60 | 31.88 |
| U**EC45/45/90 | 4 WAY 450-450 900R | 450       | 900 | 1205 |               | 22.08 | 24.09 | 33.61 | 36.29 |
| U**EC60/60/30 | 4 WAY 600-600 300R | 600       | 300 | 680  | 7.89          | 10.93 | 11.73 | 16.09 | 17.16 |
| U**EC60/60/45 | 4 WAY 600-600 450R | 600       | 450 | 830  |               | 13.91 | 15.02 | 20.71 | 22.19 |
| U**EC60/60/60 | 4 WAY 600-600 600R | 600       | 600 | 980  |               | 18.71 | 20.11 | 27.62 | 29.50 |
| U**EC60/60/75 | 4 WAY 600-600 750R | 600       | 750 | 1130 |               | 21.78 | 23.49 | 32.37 | 34.65 |
| U**EC60/60/90 | 4 WAY 600-600 900R | 600       | 900 | 1280 |               | 24.86 | 26.87 | 37.11 | 39.79 |
| U**EC75/75/30 | 4 WAY 750-750 300R | 750       | 300 | 755  |               | 31.03 | 13.84 | 18.74 | 19.81 |
| U**EC75/75/45 | 4 WAY 750-750 450R | 750       | 450 | 905  |               | 16.18 | 17.29 | 23.64 | 25.05 |
| U**EC75/75/60 | 4 WAY 750-750 600R | 750       | 600 | 1055 |               | 21.49 | 22.89 | 31.13 | 33.00 |
| U**EC75/75/75 | 4 WAY 750-750 750R | 750       | 750 | 1205 |               | 23.98 | 25.69 | 35.14 | 37.42 |
| U**EC75/75/90 | 4 WAY 750-750 900R | 750       | 900 | 1355 |               | 27.22 | 29.23 | 40.09 | 42.78 |
| U**EC90/90/30 | 4 WAY 900-900 300R | 900       | 300 | 830  |               | 14.55 | 15.36 | 20.66 | 21.73 |
| U**EC90/90/45 | 4 WAY 900-900 450R | 900       | 450 | 980  |               | 17.87 | 18.98 | 25.71 | 27.18 |
| U**EC90/90/60 | 4 WAY 900-900 600R | 900       | 600 | 1130 |               | 23.68 | 25.09 | 33.90 | 35.77 |
| U**EC90/90/75 | 4 WAY 900-900 750R | 900       | 750 | 1280 |               | 27.09 | 28.80 | 39.07 | 41.35 |
| U**EC90/90/90 | 4 WAY 900-900 900R | 900       | 900 | 1430 |               | 30.50 | 32.52 | 44.24 | 46.92 |

\*\* Specify Ladder Type +Weights Shown are based on Hot Dip Galvanized - Reduced Weights for Stainless Steel on Request

## Equal Tee

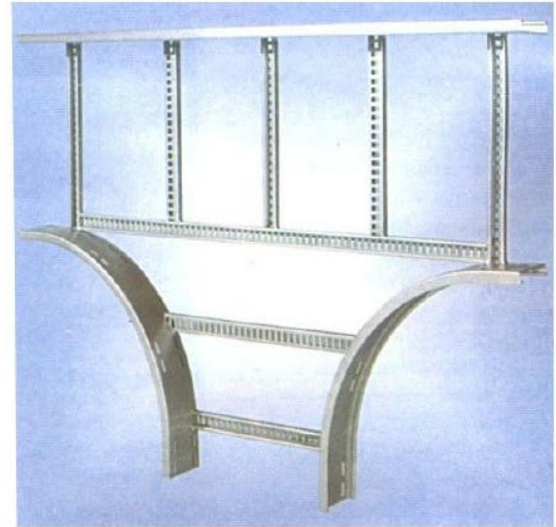
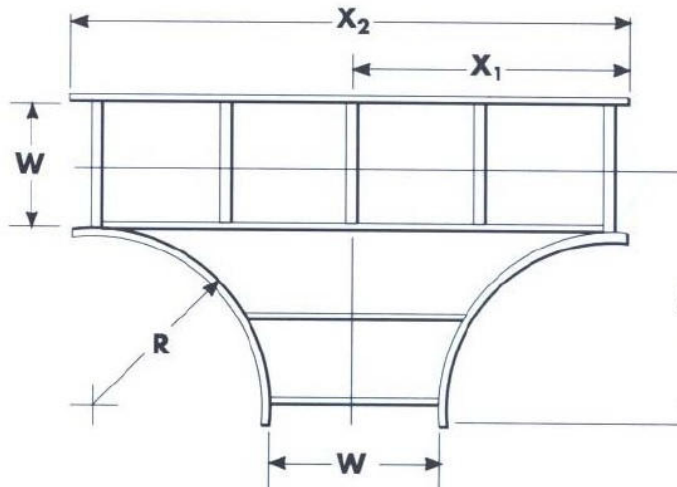
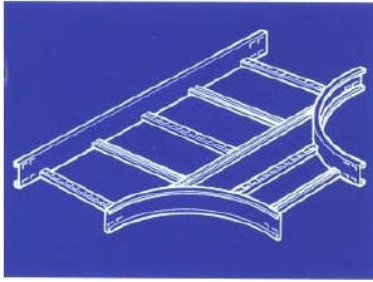

Depths : 50, 75, 100, 125, 150 mm  
 Widths : 150, 300, 450, 600, 750, 900  
 Radii : 300, 450, 600, 750, 900 mm

| Part No.      | Description        | Dimension |     |      |      | Weight ((H): Kg) |       |       |       |       |
|---------------|--------------------|-----------|-----|------|------|------------------|-------|-------|-------|-------|
|               |                    | W         | R   | X1   | X2   | U50              | U75   | U10   | U12   | U15   |
| U**ET15/15/30 | E/TEE 150-150 300R | 150       | 300 | 445  | 910  | 4.16             | 5.32  | 6.01  | 8.69  | 9.62  |
| U**ET15/15/45 | E/TEE 150-150 450R | 150       | 450 | 605  | 1210 |                  | 7.19  | 8.13  | 11.76 | 13.02 |
| U**ET15/15/60 | E/TEE 150-150 600R | 150       | 600 | 755  | 1510 |                  | 9.46  | 10.65 | 15.33 | 16.92 |
| U**ET15/15/75 | E/TEE 150-150 750R | 150       | 750 | 905  | 1810 |                  | 11.38 | 12.81 | 18.46 | 20.37 |
| U**ET15/15/90 | E/TEE 150-150 900R | 150       | 900 | 1055 | 2110 |                  | 13.30 | 14.98 | 21.59 | 23.83 |
| U**ET30/30/30 | E/TEE 300-300 300R | 300       | 300 | 530  | 1060 | 5.12             | 6.73  | 7.47  | 10.61 | 11.60 |
| U**ET30/30/45 | E/TEE 300-300 450R | 300       | 450 | 680  | 1360 |                  | 8.48  | 9.47  | 13.52 | 14.84 |
| U**ET30/30/60 | E/TEE 300-300 600R | 300       | 600 | 830  | 1660 |                  | 11.09 | 12.32 | 17.52 | 19.17 |
| U**ET30/30/75 | E/TEE 300-300 750R | 300       | 750 | 980  | 1960 |                  | 13.17 | 14.66 | 20.86 | 22.84 |
| U**ET30/30/90 | E/TEE 300-300 900R | 300       | 900 | 1130 | 2260 |                  | 15.26 | 16.99 | 24.20 | 26.51 |
| U**ET45/45/30 | E/TEE 450-450 300R | 450       | 300 | 605  | 1210 | 5.99             | 8.02  | 8.81  | 12.37 | 13.43 |
| U**ET45/45/45 | E/TEE 450-450 450R | 450       | 450 | 755  | 1510 |                  | 10.23 | 11.26 | 15.87 | 17.25 |
| U**ET45/45/60 | E/TEE 450-450 600R | 450       | 600 | 905  | 1810 |                  | 13.17 | 14.46 | 20.29 | 22.00 |
| U**ET45/45/75 | E/TEE 450-450 750R | 450       | 750 | 1055 | 2110 |                  | 15.43 | 16.96 | 23.84 | 25.88 |
| U**ET45/45/90 | E/TEE 450-450 900R | 450       | 900 | 1055 | 2110 |                  | 17.22 | 19.00 | 26.82 | 29.19 |
| U**ET60/60/30 | E/TEE 600-600 300R | 600       | 300 | 680  | 1360 | 6.86             | 9.31  | 10.14 | 14.14 | 15.25 |
| U**ET60/60/45 | E/TEE 600-600 450R | 600       | 450 | 830  | 1660 |                  | 11.68 | 12.77 | 17.84 | 19.29 |
| U**ET60/60/60 | E/TEE 600-600 600R | 600       | 600 | 980  | 1960 |                  | 14.97 | 16.30 | 22.69 | 24.47 |
| U**ET60/60/75 | E/TEE 600-600 750R | 600       | 750 | 1130 | 2260 |                  | 17.39 | 18.97 | 26.46 | 28.56 |
| U**ET60/60/90 | E/TEE 600-600 900R | 600       | 900 | 1280 | 2560 |                  | 19.82 | 21.64 | 30.22 | 32.66 |
| U**ET75/75/30 | E/TEE 750-750 300R | 750       | 300 | 755  | 1510 |                  | 11.39 | 12.28 | 16.90 | 18.08 |
| U**ET75/75/45 | E/TEE 750-750 450R | 750       | 450 | 905  | 1810 |                  | 13.94 | 15.07 | 20.82 | 22.33 |
| U**ET75/75/60 | E/TEE 750-750 600R | 750       | 600 | 1055 | 2110 |                  | 17.56 | 18.94 | 26.10 | 27.94 |
| U**ET75/75/75 | E/TEE 750-750 750R | 750       | 750 | 1205 | 2410 |                  | 19.36 | 20.98 | 29.07 | 31.24 |
| U**ET75/75/90 | E/TEE 750-750 900R | 750       | 900 | 1355 | 2710 |                  | 21.95 | 23.82 | 33.05 | 35.55 |
| U**ET90/90/30 | E/TEE 900-900 300R | 900       | 300 | 830  | 1660 |                  | 12.85 | 13.78 | 18.88 | 20.12 |
| U**ET90/90/45 | E/TEE 900-900 450R | 900       | 450 | 980  | 1960 |                  | 15.56 | 16.74 | 23.01 | 24.58 |
| U**ET90/90/60 | E/TEE 900-900 600R | 900       | 600 | 1130 | 2260 |                  | 19.52 | 20.95 | 28.71 | 30.62 |
| U**ET90/90/75 | E/TEE 900-900 750R | 900       | 750 | 1280 | 2560 |                  | 22.29 | 23.96 | 32.91 | 35.14 |
| U**ET90/90/90 | E/TEE 900-900 900R | 900       | 900 | 1430 | 2860 |                  | 25.05 | 26.97 | 37.10 | 39.66 |

\*\* Specify Ladder Type +Weights Shown are based on Hot Dip Galvanized - Reduced Weights for Stainless Steel on Request

## Unequal Tee 150

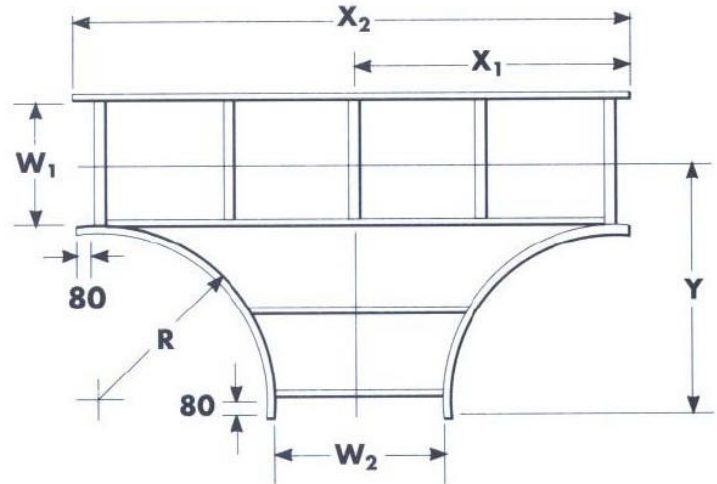
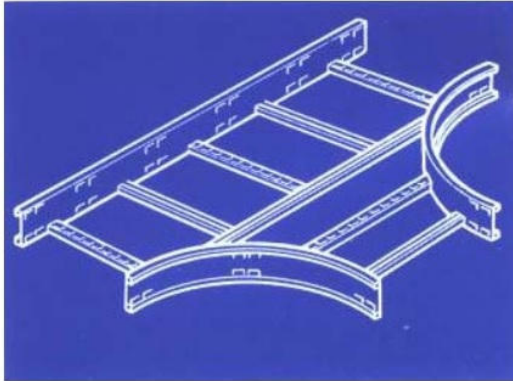

| Part No.      | Description        | Dimensions |     |     |      |      |      | Weight (Ht) Kg |       |       |       |       |
|---------------|--------------------|------------|-----|-----|------|------|------|----------------|-------|-------|-------|-------|
|               |                    | W1         | W2  | R   | X1   | Y    | X2   | U50            | U75   | U10   | U12   | U15   |
| U**UT15/30/30 | U/TEE 150-300 300R | 150        | 300 | 300 | 530  | 455  | 1060 |                | 6.05  | 6.80  | 9.76  | 10.75 |
| U**UT15/30/45 | U/TEE 150-300 450R | 150        | 300 | 450 | 680  | 605  | 1360 |                | 7.80  | 8.79  | 12.67 | 13.99 |
| U**UT15/30/60 | U/TEE 150-300 600R | 150        | 300 | 600 | 830  | 755  | 1660 |                | 10.24 | 11.48 | 16.46 | 18.10 |
| U**UT15/30/75 | U/TEE 150-300 750R | 150        | 300 | 750 | 980  | 905  | 1960 |                | 12.16 | 13.64 | 19.58 | 21.56 |
| U**UT15/30/90 | U/TEE 150-300 900R | 150        | 300 | 900 | 1130 | 1055 | 2260 |                | 14.08 | 15.81 | 22.71 | 25.02 |
| U**UT15/45/30 | U/TEE 150-450 300R | 150        | 450 | 300 | 605  | 455  | 1210 |                | 6.67  | 7.46  | 10.67 | 11.72 |
| U**UT15/45/45 | U/TEE 150-450 450R | 150        | 450 | 450 | 755  | 605  | 1510 |                | 8.54  | 9.57  | 13.69 | 15.12 |
| U**UT15/45/60 | U/TEE 150-450 600R | 150        | 450 | 600 | 905  | 755  | 1810 |                | 11.15 | 12.43 | 17.73 | 19.44 |
| U**UT15/45/75 | U/TEE 150-450 750R | 150        | 450 | 750 | 1055 | 905  | 2110 |                | 13.06 | 14.59 | 20.86 | 22.90 |
| U**UT15/45/90 | U/TEE 150-450 900R | 150        | 450 | 900 | 1205 | 1055 | 2410 |                | 14.86 | 16.64 | 23.83 | 26.20 |
| U**UT15/60/30 | U/TEE 150-600 300R | 150        | 600 | 300 | 680  | 455  | 1360 |                | 7.28  | 8.12  | 11.58 | 12.70 |
| U**UT15/60/45 | U/TEE 150-600 450R | 150        | 600 | 450 | 830  | 605  | 1660 |                | 9.15  | 10.23 | 14.65 | 16.09 |
| U**UT15/60/60 | U/TEE 150-600 600R | 150        | 600 | 600 | 980  | 755  | 1960 |                | 11.93 | 13.26 | 18.86 | 20.63 |
| U**UT15/60/75 | U/TEE 150-600 750R | 150        | 600 | 750 | 1130 | 905  | 2260 |                | 13.85 | 15.42 | 21.98 | 24.09 |
| U**UT15/60/90 | U/TEE 150-600 900R | 150        | 600 | 900 | 1280 | 1055 | 2560 |                | 15.76 | 17.59 | 25.11 | 27.55 |
| U**UT15/75/30 | U/TEE 150-750 300R | 150        | 750 | 300 | 755  | 455  | 1510 |                | 8.01  | 8.90  | 12.64 | 13.82 |
| U**UT15/75/45 | U/TEE 150-750 450R | 150        | 750 | 450 | 905  | 605  | 1810 |                | 9.88  | 11.02 | 15.71 | 17.22 |
| U**UT15/75/60 | U/TEE 150-750 600R | 150        | 750 | 600 | 1055 | 755  | 2110 |                | 12.83 | 14.21 | 20.13 | 21.97 |
| U**UT15/75/75 | U/TEE 150-750 750R | 150        | 750 | 750 | 1205 | 905  | 2410 |                | 14.63 | 16.25 | 23.11 | 25.28 |
| U**UT15/75/90 | U/TEE 150-750 900R | 150        | 750 | 900 | 1355 | 1055 | 2710 |                | 16.54 | 18.42 |       | 28.73 |
| U**UT15/90/30 | U/TEE 150-900 300R | 150        | 900 | 300 | 830  | 455  | 1660 |                | 8.63  | 9.56  | 13.55 | 14.80 |
| U**UT15/90/45 | U/TEE 150-900 450R | 150        | 900 | 450 | 980  | 605  | 1960 |                | 10.50 | 11.68 | 16.62 | 18.19 |
| U**UT15/90/60 | U/TEE 150-900 600R | 150        | 900 | 600 | 1130 | 755  | 2260 |                | 13.61 | 15.04 | 21.26 | 23.16 |
| U**UT15/90/75 | U/TEE 150-900 750R | 150        | 900 | 750 | 1280 | 905  | 2560 |                | 15.53 | 17.20 | 24.38 | 26.62 |
| U**UT15/90/90 | U/TEE 150-900 900R | 150        | 900 | 900 | 1430 | 1055 | 2860 |                | 17.45 | 19.37 | 27.51 | 30.07 |

\*\* Specify Ladder Type +Weights Shown are based on Hot Dip Galvanized - Reduced Weights for Stainless Steel on Request

## Unequal Tee 300

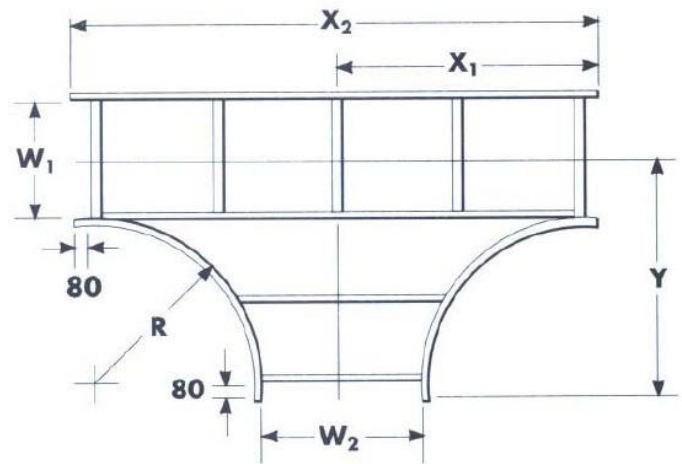
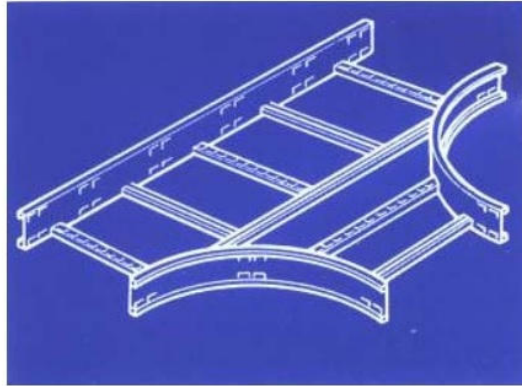

| Part No.      | Description        | Dimensions |     |     |      |      |      |       | Weight ((H) Kg) |       |       |     |  |
|---------------|--------------------|------------|-----|-----|------|------|------|-------|-----------------|-------|-------|-----|--|
|               |                    | W1         | W2  | R   | X1   | Y    | X2   | U50   | U75             | U10   | U12   | U15 |  |
| U**UT30/15/30 | U/TEE 300-150 300R | 300        | 150 | 300 | 455  | 530  | 910  | 5.83  | 6.52            | 9.33  | 10.26 |     |  |
| U**UT30/15/45 | U/TEE 300-150 450R | 300        | 150 | 450 | 605  | 680  | 1210 | 7.87  | 8.81            | 12.61 | 13.87 |     |  |
| U**UT30/15/60 | U/TEE 300-150 600R | 300        | 150 | 600 | 755  | 830  | 1510 | 10.31 | 11.49           | 16.40 | 17.98 |     |  |
| U**UT30/15/75 | U/TEE 300-150 750R | 300        | 150 | 750 | 905  | 980  | 1810 | 12.39 | 13.83           | 19.74 | 21.65 |     |  |
| U**UT30/15/90 | U/TEE 300-150 900R | 300        | 150 | 900 | 1055 | 1130 | 2110 | 14.48 | 16.16           | 23.08 | 25.32 |     |  |
| U**UT30/45/30 | U/TEE 300-450 300R | 300        | 450 | 300 | 605  | 530  | 1210 | 7.34  | 8.13            | 11.52 | 12.57 |     |  |
| U**UT30/45/45 | U/TEE 300-450 450R | 300        | 450 | 450 | 755  | 680  | 1510 | 9.38  | 10.42           | 14.80 | 16.18 |     |  |
| U**UT30/45/60 | U/TEE 300-450 600R | 300        | 450 | 600 | 905  | 830  | 1810 | 12.16 | 13.44           | 19.01 | 20.72 |     |  |
| U**UT30/45/75 | U/TEE 300-450 750R | 300        | 450 | 750 | 1055 | 980  | 2110 | 14.25 | 15.78           | 22.35 | 24.39 |     |  |
| U**UT30/45/90 | U/TEE 300-450 900R | 300        | 450 | 900 | 1205 | 1130 | 2410 | 16.04 | 17.82           | 25.53 | 27.70 |     |  |
| U**UT30/60/30 | U/TEE 300-600 300R | 300        | 600 | 300 | 680  | 530  | 1360 | 7.96  | 8.79            | 12.43 | 13.55 |     |  |
| U**UT30/60/45 | U/TEE 300-600 450R | 300        | 600 | 450 | 830  | 680  | 1660 | 9.99  | 11.08           | 15.71 | 17.16 |     |  |
| U**UT30/60/60 | U/TEE 300-600 600R | 300        | 600 | 600 | 980  | 830  | 1960 | 12.94 | 14.27           | 20.13 | 21.91 |     |  |
| U**UT30/60/75 | U/TEE 300-600 750R | 300        | 600 | 750 | 1130 | 980  | 2260 | 15.03 | 16.61           | 23.48 | 25.58 |     |  |
| U**UT30/60/90 | U/TEE 300-600 900R | 300        | 600 | 900 | 1280 | 1130 | 2560 | 17.11 | 18.94           | 26.82 | 29.25 |     |  |
| U**UT30/75/30 | U/TEE 300-750 300R | 300        | 750 | 300 | 755  | 530  | 1510 | 8.86  | 9.74            | 13.71 | 14.89 |     |  |
| U**UT30/75/45 | U/TEE 300-750 450R | 300        | 750 | 450 | 905  | 680  | 1810 | 10.90 | 12.03           | 16.99 | 18.50 |     |  |
| U**UT30/75/60 | U/TEE 300-750 600R | 300        | 750 | 600 | 1055 | 830  | 2110 | 14.01 | 15.39           | 21.62 | 23.46 |     |  |
| U**UT30/75/75 | U/TEE 300-750 750R | 300        | 750 | 750 | 1205 | 980  | 2410 | 15.81 | 17.44           | 24.60 | 26.77 |     |  |
| U**UT30/75/90 | U/TEE 300-750 900R | 300        | 750 | 900 | 1355 | 1130 | 2710 | 17.67 | 19.54           | 27.65 | 30.15 |     |  |
| U**UT30/90/30 | U/TEE 300-900 300R | 300        | 900 | 300 | 830  | 530  | 1660 | 9.47  | 10.40           | 14.62 | 15.86 |     |  |
| U**UT30/90/45 | U/TEE 300-900 450R | 300        | 900 | 450 | 980  | 680  | 1960 | 11.51 | 12.69           | 17.90 | 19.47 |     |  |
| U**UT30/90/60 | U/TEE 300-900 600R | 300        | 900 | 600 | 1130 | 830  | 2260 | 14.79 | 16.22           | 22.75 | 24.65 |     |  |
| U**UT30/90/75 | U/TEE 300-900 750R | 300        | 900 | 750 | 1280 | 980  | 2560 | 16.88 | 18.56           | 26.09 | 28.32 |     |  |
| U**UT30/90/90 | U/TEE 300-900 900R | 300        | 900 | 900 | 1430 | 1130 | 2860 | 18.97 | 20.89           | 29.43 | 31.99 |     |  |

\*\* Specify Ladder Type +Weights Shown are based on Hot Dip Galvanized - Reduced Weights for Stainless Steel on Request

## Unequal Tee 450

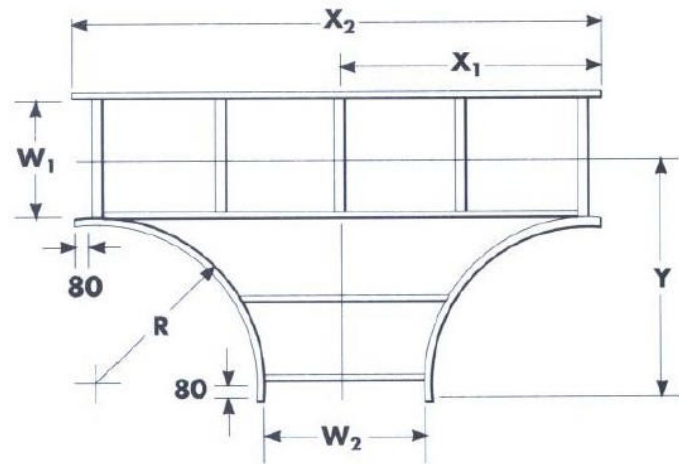
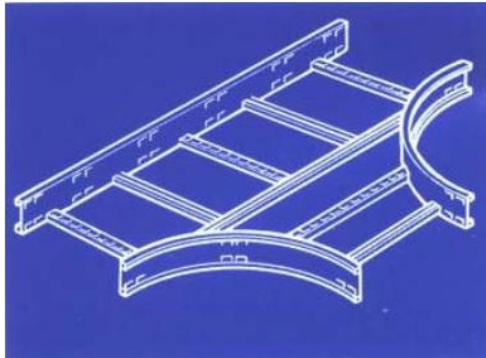

| Part No.      | Description        | Dimensions |     |     |      |      |      | Weight ((H) Kg) |       |       |       |     |
|---------------|--------------------|------------|-----|-----|------|------|------|-----------------|-------|-------|-------|-----|
|               |                    | W1         | W2  | R   | X1   | Y    | X2   | U50             | U75   | U10   | U12   | U15 |
| U**UT45/15/30 | U/TEE 450-150 300R | 450        | 150 | 300 | 455  | 605  | 910  | 6.33            | 7.03  | 9.97  | 10.90 |     |
| U**UT45/15/45 | U/TEE 450-150 450R | 450        | 150 | 450 | 605  | 755  | 1210 | 8.54            | 9.48  | 13.47 | 14.72 |     |
| U**UT45/15/60 | U/TEE 450-150 600R | 450        | 150 | 600 | 755  | 905  | 1510 | 11.15           | 12.34 | 17.46 | 19.05 |     |
| U**UT45/15/75 | U/TEE 450-150 750R | 450        | 150 | 750 | 905  | 1055 | 1810 | 13.41           | 14.84 | 21.02 | 22.93 |     |
| U**UT45/15/90 | U/TEE 450-150 900R | 450        | 150 | 900 | 1055 | 1205 | 2110 | 15.66           | 17.34 | 24.57 | 26.81 |     |
| U**UT45/30/30 | U/TEE 450-300 300R | 450        | 300 | 300 | 530  | 605  | 1210 | 7.41            | 8.15  | 11.46 | 12.45 |     |
| U**UT45/30/45 | U/TEE 450-300 450R | 450        | 300 | 450 | 680  | 755  | 1510 | 9.15            | 10.14 | 14.38 | 15.69 |     |
| U**UT45/30/60 | U/TEE 450-300 600R | 450        | 300 | 600 | 830  | 905  | 1810 | 11.93           | 13.17 | 18.59 | 20.23 |     |
| U**UT45/30/75 | U/TEE 450-300 750R | 450        | 300 | 750 | 980  | 1055 | 2110 | 14.19           | 15.67 | 22.14 | 24.12 |     |
| U**UT45/30/90 | U/TEE 450-300 900R | 450        | 300 | 900 | 1130 | 1205 | 2410 | 16.44           | 18.17 | 25.69 | 28.00 |     |
| U**UT45/60/30 | U/TEE 450-600 300R | 450        | 600 | 300 | 680  | 605  | 1360 | 8.63            | 9.47  | 13.28 | 14.40 |     |
| U**UT45/60/45 | U/TEE 450-600 450R | 450        | 600 | 450 | 830  | 755  | 1660 | 10.84           | 11.92 | 16.78 | 18.22 |     |
| U**UT45/60/60 | U/TEE 450-600 600R | 450        | 600 | 600 | 980  | 905  | 1960 | 13.95           | 15.29 | 21.41 | 23.19 |     |
| U**UT45/60/75 | U/TEE 450-600 750R | 450        | 600 | 750 | 1130 | 1055 | 2260 | 16.21           | 17.79 | 24.97 | 27.07 |     |
| U**UT45/60/90 | U/TEE 450-600 900R | 450        | 600 | 900 | 1280 | 1205 | 2560 | 18.46           | 20.29 | 28.52 | 30.95 |     |
| U**UT45/75/30 | U/TEE 450-750 300R | 450        | 750 | 300 | 755  | 605  | 1510 | 9.70            | 10.59 | 14.77 | 15.95 |     |
| U**UT45/75/45 | U/TEE 450-750 450R | 450        | 750 | 450 | 905  | 755  | 1810 | 11.91           | 13.04 | 18.27 | 19.78 |     |
| U**UT45/75/60 | U/TEE 450-750 600R | 450        | 750 | 600 | 1055 | 905  | 2110 | 15.19           | 16.57 | 23.12 | 24.95 |     |
| U**UT45/75/75 | U/TEE 450-750 750R | 450        | 750 | 750 | 1205 | 1055 | 2410 | 16.99           | 18.62 | 26.09 | 28.26 |     |
| U**UT45/75/90 | U/TEE 450-750 900R | 450        | 750 | 900 | 1355 | 1205 | 2710 | 19.25           | 21.12 | 29.64 | 32.14 |     |
| U**UT45/90/30 | U/TEE 450-900 300R | 450        | 900 | 300 | 830  | 605  | 1660 | 10.31           | 11.25 | 15.68 | 16.93 |     |
| U**UT45/90/45 | U/TEE 450-900 450R | 450        | 900 | 450 | 980  | 755  | 1960 | 12.52           | 13.70 | 19.18 | 20.75 |     |
| U**UT45/90/60 | U/TEE 450-900 600R | 450        | 900 | 600 | 1130 | 905  | 2260 | 15.98           | 17.40 | 24.24 | 27.84 |     |
| U**UT45/90/75 | U/TEE 450-900 750R | 450        | 900 | 750 | 1280 | 1055 | 2560 | 18.23           | 19.91 | 27.79 | 30.03 |     |
| U**UT45/90/90 | U/TEE 450-900 900R | 450        | 900 | 900 | 1430 | 1205 | 2860 | 20.49           | 22.41 | 31.35 | 33.91 |     |

\*\* Specify Ladder Type +Weights Shown are based on Hot Dip Galvanized - Reduced Weights for Stainless Steel on Request

## Unequal Tee 600

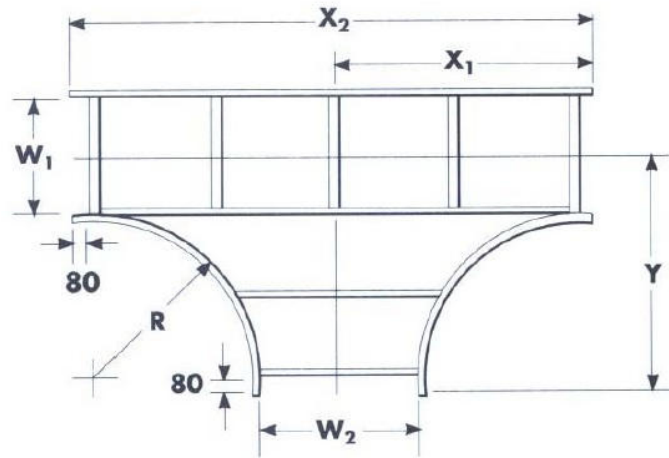
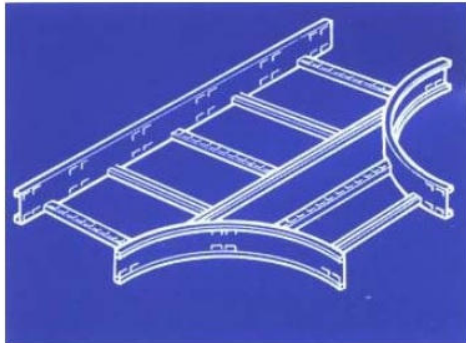

| Part No.      | Description        | Dimensions |     |     |      |      |      |       | Weight (H) Kg |       |       |     |  |
|---------------|--------------------|------------|-----|-----|------|------|------|-------|---------------|-------|-------|-----|--|
|               |                    | W1         | W2  | R   | X1   | Y    | X2   | U50   | U75           | U10   | U12   | U15 |  |
| U**UT60/15/30 | U/TEE 600-150 300R | 600        | 150 | 300 | 455  | 680  | 910  | 6.84  | 7.53          | 10.61 | 11.54 |     |  |
| U**UT60/15/45 | U/TEE 600-150 450R | 600        | 150 | 450 | 605  | 830  | 1210 | 9.22  | 10.16         | 14.32 | 15.57 |     |  |
| U**UT60/15/60 | U/TEE 600-150 600R | 600        | 150 | 600 | 755  | 980  | 1510 | 11.99 | 13.18         | 18.53 | 20.11 |     |  |
| U**UT60/15/75 | U/TEE 600-150 750R | 600        | 150 | 750 | 905  | 1130 | 1810 | 14.42 | 15.85         | 22.30 | 24.21 |     |  |
| U**UT60/15/90 | U/TEE 600-150 900R | 600        | 150 | 900 | 1055 | 1280 | 2110 | 16.84 | 18.53         | 26.06 | 28.30 |     |  |
| U**UT60/30/30 | U/TEE 600-300 300R | 600        | 300 | 300 | 530  | 680  | 1060 | 8.08  | 8.82          | 12.32 | 13.30 |     |  |
| U**UT60/30/45 | U/TEE 600-300 450R | 600        | 300 | 450 | 680  | 830  | 1360 | 9.83  | 10.82         | 15.23 | 16.55 |     |  |
| U**UT60/30/60 | U/TEE 600-300 600R | 600        | 300 | 600 | 830  | 980  | 1660 | 12.78 | 14.01         | 19.65 | 21.30 |     |  |
| U**UT60/30/75 | U/TEE 600-300 750R | 600        | 300 | 750 | 980  | 1130 | 1960 | 15.20 | 16.68         | 23.42 | 25.40 |     |  |
| U**UT60/30/90 | U/TEE 600-300 900R | 600        | 300 | 900 | 1130 | 1280 | 2260 | 17.62 | 19.35         | 27.18 | 29.49 |     |  |
| U**UT60/45/30 | U/TEE 600-450 300R | 600        | 450 | 300 | 605  | 680  | 1210 | 8.69  | 9.48          | 13.23 | 14.28 |     |  |
| U**UT60/45/45 | U/TEE 600-450 450R | 600        | 450 | 450 | 755  | 830  | 1510 | 11.07 | 12.11         | 16.93 | 18.31 |     |  |
| U**UT60/45/60 | U/TEE 600-450 600R | 600        | 450 | 600 | 905  | 980  | 1810 | 14.19 | 15.47         | 21.57 | 23.28 |     |  |
| U**UT60/45/75 | U/TEE 600-450 750R | 600        | 450 | 750 | 1055 | 1130 | 2110 | 16.61 | 18.14         | 25.34 | 27.38 |     |  |
| U**UT60/45/90 | U/TEE 600-450 900R | 600        | 450 | 900 | 1205 | 1280 | 2410 | 18.41 | 20.18         | 28.31 | 30.68 |     |  |
| U**UT60/75/30 | U/TEE 600-750 300R | 600        | 750 | 300 | 755  | 680  | 1510 | 10.55 | 11.43         | 15.84 | 17.02 |     |  |
| U**UT60/75/45 | U/TEE 600-750 450R | 600        | 750 | 450 | 905  | 830  | 1810 | 12.92 | 14.06         | 19.54 | 21.05 |     |  |
| U**UT60/75/60 | U/TEE 600-750 600R | 600        | 750 | 600 | 1055 | 980  | 2110 | 16.38 | 17.76         | 24.61 | 26.45 |     |  |
| U**UT60/75/75 | U/TEE 600-750 750R | 600        | 750 | 750 | 1205 | 1130 | 2410 | 18.17 | 19.80         | 27.58 | 29.75 |     |  |
| U**UT60/75/90 | U/TEE 600-750 900R | 600        | 750 | 900 | 1355 | 1280 | 2710 | 20.60 | 22.47         | 31.35 | 33.85 |     |  |
| U**UT60/90/30 | U/TEE 600-900 300R | 600        | 900 | 300 | 830  | 680  | 1660 | 11.16 | 12.09         | 16.75 | 17.99 |     |  |
| U**UT60/90/45 | U/TEE 600-900 450R | 600        | 900 | 450 | 980  | 830  | 1960 | 13.54 | 14.72         | 20.45 | 22.03 |     |  |
| U**UT60/90/60 | U/TEE 600-900 600R | 600        | 900 | 600 | 1130 | 980  | 2260 | 17.16 | 18.59         | 25.73 | 27.83 |     |  |
| U**UT60/90/75 | U/TEE 600-900 750R | 600        | 900 | 750 | 1280 | 1130 | 2560 | 19.58 | 21.26         | 29.50 | 31.73 |     |  |
| U**UT60/90/90 | U/TEE 600-900 900R | 600        | 900 | 900 | 1430 | 1280 | 2860 | 22.01 | 23.93         | 33.26 | 36.40 |     |  |

\*\* Specify Ladder Type +Weights Shown are based on Hot Dip Galvanized - Reduced Weights for Stainless Steel on Request

## Unequal Tee 750

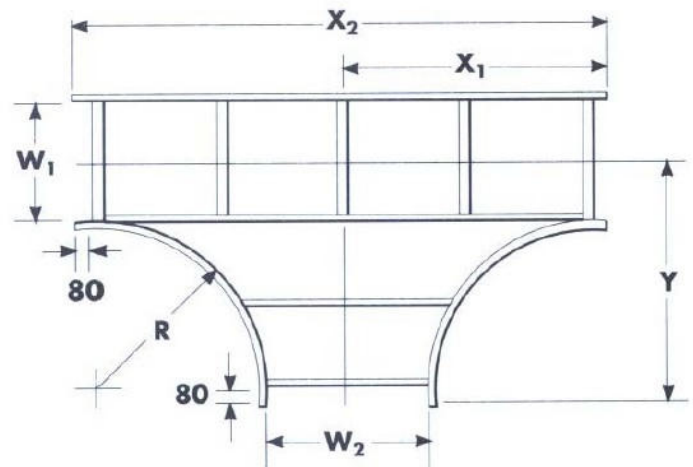
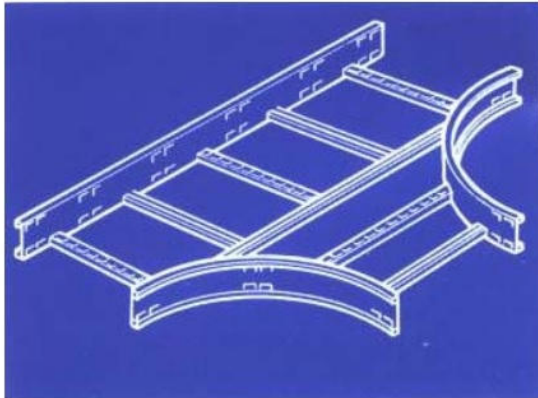

| Part No.      | Description        | Dimensions |     |     |      |      |      | Weight (H) Kg |       |       |       |       |
|---------------|--------------------|------------|-----|-----|------|------|------|---------------|-------|-------|-------|-------|
|               |                    | W1         | W2  | R   | X1   | Y    | X2   | U50           | U75   | U10   | U12   | U15   |
| U**UT75/15/30 | U/TEE 750-150 300R | 750        | 150 | 300 | 455  | 755  | 910  |               | 7.35  | 8.04  | 11.25 | 12.18 |
| U**UT75/15/45 | U/TEE 750-150 450R | 750        | 150 | 450 | 605  | 905  | 1210 |               | 9.89  | 10.83 | 15.17 | 16.42 |
| U**UT75/15/60 | U/TEE 750-150 600R | 750        | 150 | 600 | 755  | 1055 | 1510 |               | 12.84 | 14.03 | 19.59 | 21.18 |
| U**UT75/15/75 | U/TEE 750-150 750R | 750        | 150 | 750 | 905  | 1205 | 1810 |               | 15.43 | 16.87 | 23.57 | 25.49 |
| U**UT75/15/90 | U/TEE 750-150 900R | 750        | 150 | 900 | 1055 | 1355 | 2110 |               | 18.03 | 19.71 | 27.55 | 29.80 |
| U**UT75/30/30 | U/TEE 750-300 300R | 750        | 300 | 300 | 530  | 755  | 1060 |               | 8.76  | 9.50  | 13.17 | 14.16 |
| U**UT75/30/45 | U/TEE 750-300 450R | 750        | 300 | 450 | 680  | 905  | 1360 |               | 10.50 | 11.49 | 16.08 | 17.40 |
| U**UT75/30/60 | U/TEE 750-300 600R | 750        | 300 | 600 | 830  | 1055 | 1660 |               | 13.62 | 14.86 | 20.72 | 22.36 |
| U**UT75/30/75 | U/TEE 750-300 750R | 750        | 300 | 750 | 980  | 1205 | 1960 |               | 16.21 | 17.70 | 24.70 | 26.67 |
| U**UT75/30/90 | U/TEE 750-300 900R | 750        | 300 | 900 | 1130 | 1355 | 2260 |               | 18.81 | 20.54 | 28.68 | 30.98 |
| U**UT75/45/30 | U/TEE 750-450 300R | 750        | 450 | 300 | 605  | 755  | 1210 |               | 9.37  | 10.16 | 14.08 | 15.13 |
| U**UT75/45/45 | U/TEE 750-450 450R | 750        | 450 | 450 | 755  | 905  | 1510 |               | 11.91 | 12.95 | 18.00 | 19.38 |
| U**UT75/45/60 | U/TEE 750-450 600R | 750        | 450 | 600 | 905  | 1055 | 1810 |               | 15.20 | 16.48 | 22.85 | 24.56 |
| U**UT75/45/75 | U/TEE 750-450 750R | 750        | 450 | 750 | 1055 | 1205 | 2110 |               | 17.79 | 19.32 | 26.83 | 28.87 |
| U**UT75/45/90 | U/TEE 750-450 900R | 750        | 450 | 900 | 1205 | 1355 | 2410 |               | 19.59 | 21.37 | 29.80 | 32.17 |
| U**UT75/60/30 | U/TEE 750-600 300R | 750        | 600 | 300 | 680  | 755  | 1360 |               | 9.98  | 10.82 | 14.99 | 16.10 |
| U**UT75/60/45 | U/TEE 750-600 450R | 750        | 600 | 450 | 830  | 905  | 1660 |               | 12.53 | 13.61 | 18.91 | 20.35 |
| U**UT75/60/60 | U/TEE 750-600 600R | 750        | 600 | 600 | 980  | 1055 | 1960 |               | 15.98 | 17.31 | 23.97 | 25.74 |
| U**UT75/60/75 | U/TEE 750-600 750R | 750        | 600 | 750 | 1130 | 1205 | 2260 |               | 18.57 | 20.15 | 27.95 | 30.05 |
| U**UT75/60/90 | U/TEE 750-600 900R | 750        | 600 | 900 | 1280 | 1355 | 2560 |               | 21.17 | 22.09 | 31.93 | 34.36 |
| U**UT75/90/30 | U/TEE 750-900 300R | 750        | 900 | 300 | 830  | 755  | 1660 |               | 12.00 | 12.94 | 17.81 | 19.06 |
| U**UT75/90/45 | U/TEE 750-900 450R | 750        | 900 | 450 | 980  | 905  | 1960 |               | 14.55 | 15.73 | 21.73 | 23.31 |
| U**UT75/90/60 | U/TEE 750-900 600R | 750        | 900 | 600 | 1130 | 1055 | 2260 |               | 18.34 | 19.77 | 27.22 | 29.12 |
| U**UT75/90/75 | U/TEE 750-900 750R | 750        | 900 | 750 | 1280 | 1205 | 2560 |               | 20.93 | 22.61 | 31.20 | 33.43 |
| U**UT75/90/90 | U/TEE 750-900 900R | 750        | 900 | 900 | 1430 | 1355 | 2860 |               | 23.53 | 25.45 | 35.18 | 37.74 |

\*\* Specify Ladder Type +Weights Shown are based on Hot Dip Galvanized - Reduced Weights for Stainless Steel on Request

## Unequal Tee 900

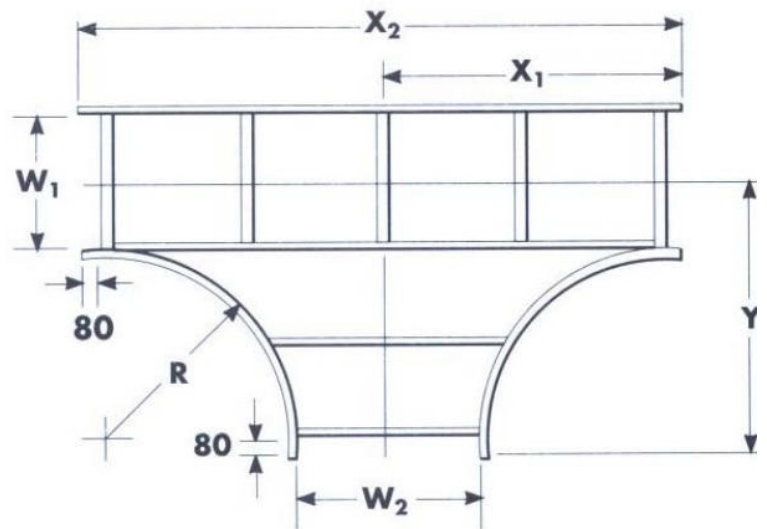
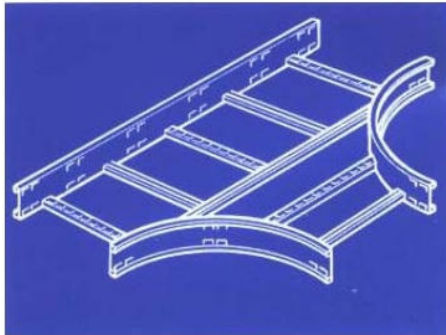

| Part No.      | Description        | Dimensions |     |     |      |      |      | Weight ((H) Kg) |       |       |       |       |
|---------------|--------------------|------------|-----|-----|------|------|------|-----------------|-------|-------|-------|-------|
|               |                    | W1         | W2  | R   | X1   | Y    | X2   | U50             | U75   | U10   | U12   | U15   |
| U**UT90/15/30 | U/TEE 900-150 300R | 900        | 150 | 300 | 455  | 830  | 910  |                 | 7.85  | 8.55  | 11.89 | 12.81 |
| U**UT90/15/45 | U/TEE 900-150 450R | 900        | 150 | 450 | 605  | 980  | 1210 |                 | 10.57 | 11.51 | 16.02 | 17.28 |
| U**UT90/15/60 | U/TEE 900-150 600R | 900        | 150 | 600 | 755  | 1130 | 1510 |                 | 13.68 | 14.87 | 20.66 | 22.24 |
| U**UT90/15/75 | U/TEE 900-150 750R | 900        | 150 | 750 | 905  | 1280 | 1810 |                 | 16.45 | 17.88 | 24.85 | 26.77 |
| U**UT90/15/90 | U/TEE 900-150 900R | 900        | 150 | 900 | 1055 | 1430 | 2110 |                 | 19.21 | 20.89 | 29.04 | 31.29 |
| U**UT90/30/30 | U/TEE 900-300 300R | 900        | 300 | 300 | 530  | 830  | 1060 |                 | 9.43  | 10.17 | 14.02 | 15.01 |
| U**UT90/30/45 | U/TEE 900-300 450R | 900        | 300 | 450 | 680  | 980  | 1360 |                 | 11.18 | 12.17 | 16.93 | 18.25 |
| U**UT90/30/60 | U/TEE 900-300 600R | 900        | 300 | 600 | 830  | 1130 | 1660 |                 | 14.47 | 15.70 | 21.78 | 23.43 |
| U**UT90/30/75 | U/TEE 900-300 750R | 900        | 300 | 750 | 980  | 1280 | 1960 |                 | 17.23 | 18.71 | 25.98 | 27.95 |
| U**UT90/30/90 | U/TEE 900-300 900R | 900        | 300 | 900 | 1130 | 1430 | 2260 |                 | 19.99 | 21.72 | 30.17 | 32.47 |
| U**UT90/45/30 | U/TEE 900-450 300R | 900        | 450 | 300 | 605  | 830  | 1210 |                 | 10.04 | 10.83 | 14.93 | 15.98 |
| U**UT90/45/45 | U/TEE 900-450 450R | 900        | 450 | 450 | 755  | 980  | 1510 |                 | 12.76 | 13.80 | 19.06 | 20.44 |
| U**UT90/45/60 | U/TEE 900-450 600R | 900        | 450 | 600 | 905  | 1130 | 1810 |                 | 16.21 | 17.50 | 24.12 | 25.84 |
| U**UT90/45/75 | U/TEE 900-450 750R | 900        | 450 | 750 | 1055 | 1280 | 2110 |                 | 18.98 | 20.51 | 28.32 | 30.36 |
| U**UT90/45/90 | U/TEE 900-450 900R | 900        | 450 | 900 | 1205 | 1430 | 2410 |                 | 20.77 | 22.55 | 31.29 | 33.66 |
| U**UT90/60/30 | U/TEE 900-600 300R | 900        | 600 | 300 | 680  | 830  | 1360 |                 | 10.66 | 11.49 | 15.84 | 16.96 |
| U**UT90/60/45 | U/TEE 900-600 450R | 900        | 600 | 450 | 830  | 980  | 1660 |                 | 13.37 | 14.46 | 19.97 | 21.42 |
| U**UT90/60/60 | U/TEE 900-600 600R | 900        | 600 | 600 | 980  | 1130 | 1960 |                 | 16.99 | 18.33 | 25.25 | 27.02 |
| U**UT90/60/75 | U/TEE 900-600 750R | 900        | 600 | 750 | 1130 | 1280 | 2260 |                 | 19.76 | 21.34 | 29.44 | 31.55 |
| U**UT90/60/90 | U/TEE 900-600 900R | 900        | 600 | 900 | 1280 | 1430 | 2560 |                 | 22.52 | 24.34 | 33.63 | 36.07 |
| U**UT90/75/30 | U/TEE 900-750 300R | 900        | 750 | 300 | 750  | 830  | 1500 |                 | 12.24 | 13.12 | 17.97 | 19.15 |
| U**UT90/75/45 | U/TEE 900-750 450R | 900        | 750 | 450 | 905  | 980  | 1810 |                 | 14.95 | 16.08 | 22.20 | 23.61 |
| U**UT90/75/60 | U/TEE 900-750 600R | 900        | 750 | 600 | 1055 | 1130 | 2110 |                 | 18.74 | 20.12 | 27.59 | 29.43 |
| U**UT90/75/75 | U/TEE 900-750 750R | 900        | 750 | 750 | 1205 | 1280 | 2410 |                 | 20.54 | 22.16 | 30.56 | 32.73 |
| U**UT90/75/90 | U/TEE 900-750 900R | 900        | 750 | 900 | 1355 | 1430 | 2710 |                 | 23.30 | 24.33 | 34.76 | 37.25 |

\*\* Specify Ladder Type +Weights Shown are based on Hot Dip Galvanized - Reduced Weights for Stainless Steel on Request

## Inside Riser

**Depths :** 50, 75, 100, 125, 150 mm  
**Width :** 150, 300, 450, 600, 750, 900mm  
**Degree :** 30°, 45°, 60°, 90°  
**Radii :** 300, 450, 600, 750, 900 mm



### 30° Inside Riser

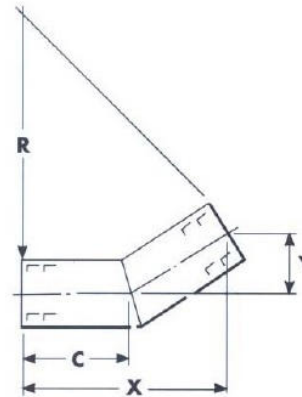
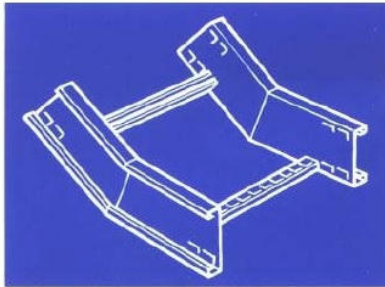

| Part No.     | Description       | Dimensions |     |     |     | Weight ((H) Kg) |      |      |      |      |      |
|--------------|-------------------|------------|-----|-----|-----|-----------------|------|------|------|------|------|
|              |                   | R          | C   | X   | Y   | 150             | 300  | 450  | 600  | 750  | 900  |
| U50I**/30/30 | I/R ** W 30° 300R | 300        | 87  | 163 | 44  | 0.78            | 1.00 | 1.21 | 1.42 |      |      |
| U50I**/30/45 | I/R ** W 30° 450R | 450        | 127 | 238 | 64  |                 |      |      |      |      |      |
| U50I**/30/60 | I/R ** W 30° 600R | 600        | 167 | 313 | 84  |                 |      |      |      |      |      |
| U50I**/30/75 | I/R ** W 30° 750R | 750        | 208 | 388 | 104 |                 |      |      |      |      |      |
| U50I**/30/90 | I/R ** W 30° 900R | 900        | 248 | 463 | 124 |                 |      |      |      |      |      |
| U75I**/30/30 | I/R ** W 30° 300R | 300        | 90  | 169 | 45  | 1.07            | 1.41 | 1.75 | 2.09 | 2.43 | 2.76 |
| U75I**/30/45 | I/R ** W 30° 450R | 450        | 131 | 244 | 65  | 1.37            | 1.70 | 2.04 | 2.38 | 2.72 | 3.06 |
| U75I**/30/60 | I/R ** W 30° 600R | 600        | 171 | 319 | 85  | 1.66            | 2.00 | 2.34 | 2.68 | 3.01 | 3.35 |
| U75I**/30/75 | I/R ** W 30° 750R | 750        | 211 | 394 | 106 | 1.96            | 2.29 | 2.63 | 2.97 | 3.31 | 3.65 |
| U75I**/30/90 | I/R ** W 30° 900R | 900        | 251 | 469 | 126 | 2.25            | 2.59 | 2.93 | 3.27 | 3.60 | 3.94 |
| U10I**/30/30 | I/R ** W 30° 300R | 300        | 94  | 175 | 47  | 1.26            | 1.60 | 1.93 | 2.27 | 2.61 | 2.95 |
| U10I**/30/45 | I/R ** W 30° 450R | 450        | 134 | 250 | 67  | 1.61            | 1.95 | 2.28 | 2.62 | 2.96 | 3.30 |
| U10I**/30/60 | I/R ** W 30° 600R | 600        | 174 | 325 | 87  | 1.95            | 2.29 | 2.63 | 2.96 | 3.30 | 3.64 |
| U10I**/30/75 | I/R ** W 30° 750R | 750        | 214 | 400 | 107 | 2.30            | 2.64 | 2.98 | 3.31 | 3.65 | 3.99 |
| U10I**/30/90 | I/R ** W 30° 900R | 900        | 255 | 475 | 127 | 2.64            | 2.98 | 3.32 | 3.66 | 4.00 | 4.33 |
| U12I**/30/30 | I/R ** W 30° 300R | 300        | 97  | 181 | 49  | 1.90            | 2.32 | 2.75 | 3.18 | 3.60 | 4.03 |
| U12I**/30/45 | I/R ** W 30° 450R | 450        | 137 | 256 | 69  | 2.41            | 2.84 | 3.27 | 3.69 | 4.12 | 4.54 |
| U12I**/30/60 | I/R ** W 30° 600R | 600        | 178 | 331 | 89  | 2.94            | 3.36 | 3.79 | 4.22 | 4.64 | 5.07 |
| U12I**/30/75 | I/R ** W 30° 750R | 750        | 218 | 406 | 109 | 3.45            | 3.88 | 4.31 | 4.73 | 5.16 | 5.58 |
| U12I**/30/90 | I/R ** W 30° 900R | 900        | 258 | 481 | 129 | 3.97            | 4.40 | 4.82 | 5.25 | 5.67 | 6.10 |
| U15I**/30/30 | I/R ** W 30° 300R | 300        | 100 | 188 | 50  | 2.19            | 2.61 | 3.04 | 3.47 | 3.89 | 4.32 |
| U15I**/30/45 | I/R ** W 30° 450R | 450        | 141 | 263 | 70  | 2.78            | 3.21 | 3.63 | 4.06 | 4.48 | 4.91 |
| U15I**/30/60 | I/R ** W 30° 600R | 600        | 181 | 338 | 90  | 3.36            | 3.79 | 4.22 | 4.64 | 5.07 | 5.49 |
| U15I**/30/75 | I/R ** W 30° 750R | 750        | 221 | 413 | 111 | 3.95            | 4.38 | 4.80 | 5.23 | 5.65 | 6.08 |
| U15I**/30/90 | I/R ** W 30° 900R | 900        | 261 | 488 | 131 | 4.54            | 4.97 | 5.39 | 5.82 | 6.25 | 6.67 |

\*\* Specify Ladder Type +Weights Shown are based on Hot Dip Galvanized - Reduced Weights for Stainless Steel on Request

## 45° Inside Riser

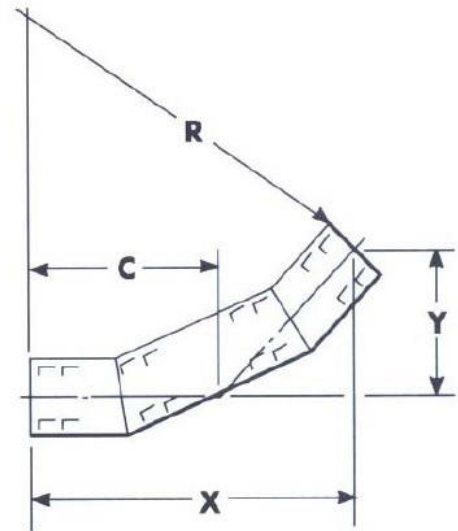
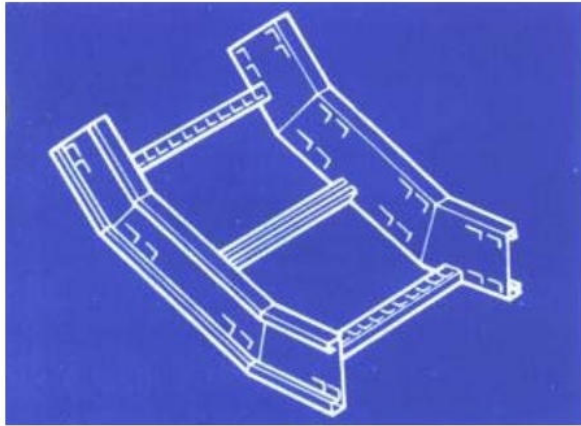

| Part No.      | Description       | Dimensions |     |     |     | Weight ((H) Kg) |      |      |      |      |      |
|---------------|-------------------|------------|-----|-----|-----|-----------------|------|------|------|------|------|
|               |                   | R          | C   | X   | Y   | 150             | 300  | 450  | 600  | 750  | 900  |
| U50IR**/45/30 | I/R ** W 45° 300R | 300        | 155 | 265 | 110 | 1.29            | 1.61 | 1.93 | 2.25 |      |      |
| U50IR**/45/45 | I/R ** W 45° 450R | 450        | 197 | 336 | 139 |                 |      |      |      |      |      |
| U50IR**/45/60 | I/R ** W 45° 600R | 600        | 259 | 442 | 183 |                 |      |      |      |      |      |
| U50IR**/45/75 | I/R ** W 45° 750R | 750        | 321 | 548 | 227 |                 |      |      |      |      |      |
| U50IR**/45/90 | I/R ** W 45° 900R | 900        | 383 | 654 | 271 |                 |      |      |      |      |      |
| U75IR**/45/30 | I/R ** W 45° 300R | 300        | 160 | 273 | 113 |                 |      | 2.76 | 3.27 | 3.78 | 4.28 |
| U75IR**/45/45 | I/R ** W 45° 450R | 450        | 202 | 345 | 143 | 2.04            | 2.54 | 3.05 | 3.56 | 4.06 | 4.57 |
| U75IR**/45/60 | I/R ** W 45° 600R | 600        | 264 | 451 | 187 | 2.47            | 2.98 | 3.49 | 3.99 | 4.50 | 5.01 |
| U75IR**/45/75 | I/R ** W 45° 750R | 750        | 326 | 557 | 231 | 2.91            | 3.42 | 3.92 | 4.43 | 4.94 | 5.44 |
| U75IR**/45/90 | I/R ** W 45° 900R | 900        | 388 | 663 | 275 | 3.35            | 3.86 | 4.36 | 4.87 | 5.38 | 5.88 |
| U10IR**/45/30 | I/R ** W 45° 300R | 300        | 165 | 282 | 117 | 2.05            | 2.56 | 3.07 | 3.57 | 4.08 | 4.59 |
| U10IR**/45/45 | I/R ** W 45° 450R | 450        | 207 | 354 | 146 | 2.39            | 2.90 | 3.40 | 3.91 | 4.42 | 4.93 |
| U10IR**/45/60 | I/R ** W 45° 600R | 600        | 269 | 460 | 190 | 2.90            | 3.41 | 3.92 | 4.42 | 4.93 | 5.44 |
| U10IR**/45/75 | I/R ** W 45° 750R | 750        | 331 | 566 | 234 | 3.42            | 3.92 | 4.43 | 4.94 | 5.44 | 5.95 |
| U10IR**/45/90 | I/R ** W 45° 900R | 900        | 394 | 672 | 278 | 3.93            | 4.44 | 4.95 | 5.45 | 5.96 | 6.47 |
| U12IR**/45/30 | I/R ** W 45° 300R | 300        | 170 | 291 | 121 | 3.09            | 3.72 | 4.36 | 5.00 | 5.64 | 6.28 |
| U12IR**/45/45 | I/R ** W 45° 450R | 450        | 212 | 362 | 150 | 3.59            | 4.23 | 4.87 | 5.51 | 6.15 | 6.78 |
| U12IR**/45/60 | I/R ** W 45° 600R | 600        | 274 | 468 | 194 | 4.36            | 5.00 | 5.64 | 6.28 | 6.92 | 7.56 |
| U12IR**/45/75 | I/R ** W 45° 750R | 750        | 337 | 575 | 238 | 5.13            | 5.77 | 6.41 | 7.05 | 7.69 | 8.33 |
| U12IR**/45/90 | I/R ** W 45° 900R | 900        | 399 | 681 | 282 | 5.91            | 6.55 | 7.18 | 7.82 | 8.48 | 9.10 |
| U15IR**/45/30 | I/R ** W 45° 300R | 300        | 176 | 300 | 124 | 3.56            | 4.19 | 4.83 | 5.47 | 6.11 | 6.75 |
| U15IR**/45/45 | I/R ** W 45° 450R | 450        | 217 | 371 | 154 | 4.13            | 4.76 | 5.40 | 6.04 | 6.68 | 7.32 |
| U15IR**/45/60 | I/R ** W 45° 600R | 600        | 280 | 477 | 198 | 5.00            | 5.64 | 6.28 | 6.92 | 7.56 | 8.20 |
| U15IR**/45/75 | I/R ** W 45° 750R | 750        | 342 | 583 | 242 | 5.87            | 6.51 | 7.15 | 7.79 | 8.43 | 9.07 |
| U15IR**/45/90 | I/R ** W 45° 900R | 900        | 404 | 689 | 286 | 6.74            | 7.38 | 8.02 | 8.66 | 9.30 | 9.94 |

\*\* Specify Ladder Type +Weights Shown are based on Hot Dip Galvanized - Reduced Weights for Stainless Steel on Request

## 60° Insider Riser

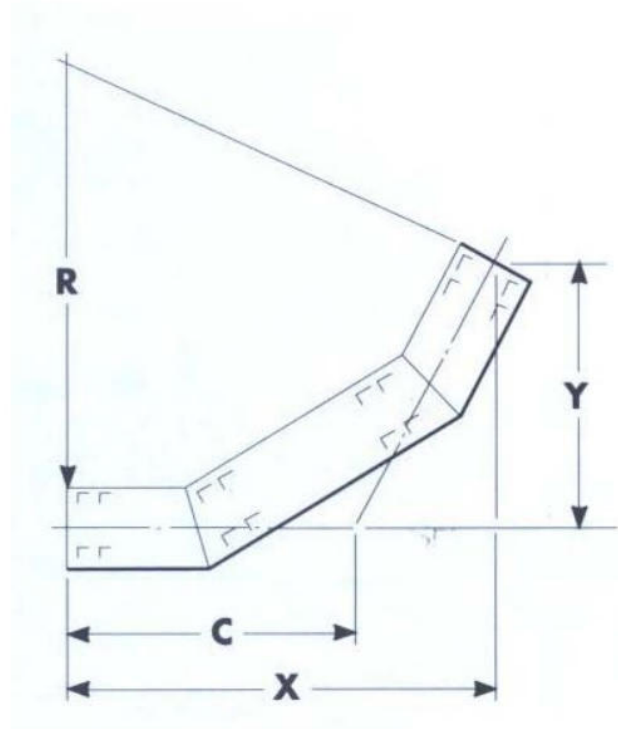

| Part No.      | Description       | Dimensions |     |     |     | Weight ((H) Kg) |      |       |       |       |       |
|---------------|-------------------|------------|-----|-----|-----|-----------------|------|-------|-------|-------|-------|
|               |                   | R          | C   | X   | Y   | 150             | 300  | 450   | 600   | 750   | 900   |
| U501R**/60/30 | I/R ** W 60° 300R | 300        | 188 | 281 | 163 | 1.45            | 1.78 | 2.10  | 2.42  |       |       |
| U501R**/60/45 | I/R ** W 60° 450R | 450        | 274 | 411 | 238 |                 |      |       |       |       |       |
| U501R**/60/60 | I/R ** W 60° 600R | 600        | 361 | 541 | 313 |                 |      |       |       |       |       |
| U501R**/60/75 | I/R ** W 60° 750R | 750        | 447 | 671 | 388 |                 |      |       |       |       |       |
| U501R**/60/90 | I/R ** W 60° 900R | 900        | 534 | 801 | 463 |                 |      |       |       |       |       |
| U751R**/60/30 | I/R ** W 60° 300R | 300        | 195 | 292 | 169 |                 |      | 2.99  | 3.50  | 4.01  | 4.51  |
| U751R**/60/45 | I/R ** W 60° 450R | 450        | 281 | 422 | 244 | 2.57            | 3.08 | 3.58  | 4.09  | 4.60  | 5.10  |
| U751R**/60/60 | I/R ** W 60° 600R | 600        | 368 | 552 | 319 | 3.15            | 3.66 | 4.17  | 4.67  | 5.18  | 5.69  |
| U751R**/60/75 | I/R ** W 60° 750R | 750        | 455 | 682 | 394 | 3.74            | 4.25 | 4.76  | 5.26  | 5.77  | 6.28  |
| U751R**/60/90 | I/R ** W 60° 900R | 900        | 541 | 812 | 469 | 4.33            | 4.84 | 5.35  | 5.85  | 6.36  | 6.87  |
| U101R**/60/30 | I/R ** W 60° 300R | 300        | 202 | 303 | 175 | 2.35            | 2.86 | 3.37  | 3.87  | 4.38  | 4.89  |
| U101R**/60/45 | I/R ** W 60° 450R | 450        | 289 | 433 | 250 | 3.04            | 3.55 | 4.05  | 4.56  | 5.07  | 5.57  |
| U101R**/60/60 | I/R ** W 60° 600R | 600        | 375 | 563 | 325 | 3.73            | 4.24 | 4.75  | 5.25  | 5.76  | 6.27  |
| U101R**/60/75 | I/R ** W 60° 750R | 750        | 462 | 693 | 400 | 4.43            | 4.93 | 5.44  | 5.95  | 6.45  | 6.96  |
| U101R**/60/90 | I/R ** W 60° 900R | 900        | 548 | 832 | 475 | 5.12            | 5.63 | 6.13  | 6.64  | 7.15  | 7.65  |
| U121R**/60/30 | I/R ** W 60° 300R | 300        | 209 | 314 | 181 | 3.58            | 4.22 | 4.86  | 5.50  | 6.14  | 6.78  |
| U121R**/60/45 | I/R ** W 60° 450R | 450        | 296 | 444 | 256 | 4.62            | 5.25 | 5.89  | 6.53  | 7.17  | 7.81  |
| U121R**/60/60 | I/R ** W 60° 600R | 600        | 382 | 574 | 331 | 5.65            | 6.29 | 6.93  | 7.57  | 8.21  | 8.85  |
| U121R**/60/75 | I/R ** W 60° 750R | 750        | 469 | 704 | 406 | 6.69            | 7.33 | 7.97  | 8.61  | 9.25  | 9.89  |
| U121R**/60/90 | I/R ** W 60° 900R | 900        | 556 | 834 | 481 | 7.73            | 8.37 | 9.01  | 9.65  | 10.29 | 10.93 |
| U151R**/60/30 | I/R ** W 60° 300R | 300        | 217 | 325 | 188 | 4.16            | 4.80 | 5.44  | 6.08  | 6.72  | 7.36  |
| U151R**/60/45 | I/R ** W 60° 450R | 450        | 303 | 455 | 263 | 5.34            | 5.98 | 6.62  | 7.26  | 7.90  | 8.53  |
| U151R**/60/60 | I/R ** W 60° 600R | 600        | 390 | 585 | 338 | 6.52            | 7.16 | 7.79  | 8.43  | 9.07  | 9.71  |
| U151R**/60/75 | I/R ** W 60° 750R | 750        | 476 | 714 | 413 | 7.69            | 8.33 | 8.97  | 9.61  | 10.25 | 10.89 |
| U151R**/60/90 | I/R ** W 60° 900R | 900        | 563 | 844 | 488 | 8.86            | 9.50 | 10.14 | 10.78 | 11.42 | 12.06 |

\*\* Specify Ladder Type +Weights Shown are based on Hot Dip Galvanized - Reduced Weights for Stainless Steel on Request

## 90° Inside Riser

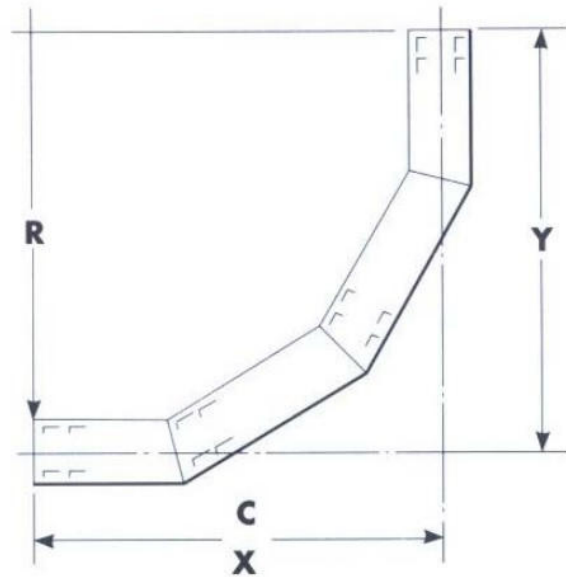
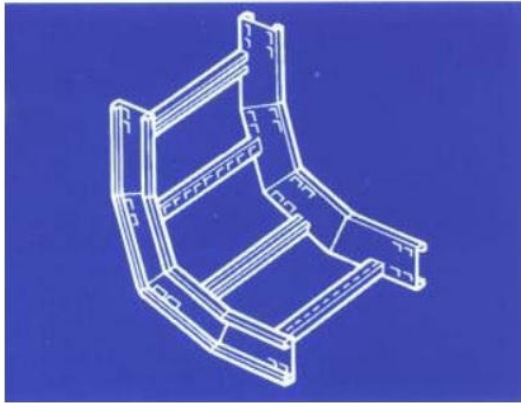

| Part No.      | Description       | Dimensions |     |     |     | Weight ((H) Kg |       |       |       |       |       |
|---------------|-------------------|------------|-----|-----|-----|----------------|-------|-------|-------|-------|-------|
|               |                   | R          | C   | X   | Y   | 150            | 300   | 450   | 600   | 750   | 900   |
| U50IR**/90/30 | I/R ** W 90° 300R | 300        | 325 | 325 | 325 | 2.13           | 2.56  | 2.99  | 3.41  |       |       |
| U50IR**/90/45 | I/R ** W 90° 450R | 450        | 475 | 475 | 475 |                |       |       |       |       |       |
| U50IR**/90/60 | I/R ** W 90° 600R | 600        | 625 | 625 | 625 |                |       |       |       |       |       |
| U50IR**/90/75 | I/R ** W 90° 750R | 750        | 775 | 775 | 775 |                |       |       |       |       |       |
| U50IR**/90/90 | I/R ** W 90° 900R | 900        | 925 | 925 | 925 |                |       |       |       |       |       |
| U75IR**/90/30 | I/R ** W 90° 300R | 300        | 338 | 338 | 338 |                |       | 4.24  | 4.91  | 5.59  | 6.26  |
| U75IR**/90/45 | I/R ** W 90° 450R | 450        | 488 | 488 | 488 | 3.77           | 4.44  | 5.12  | 5.79  | 6.47  | 7.14  |
| U75IR**/90/60 | I/R ** W 90° 600R | 600        | 638 | 638 | 638 | 4.65           | 5.32  | 6.00  | 6.68  | 7.35  | 8.03  |
| U75IR**/90/75 | I/R ** W 90° 750R | 750        | 788 | 788 | 788 | 5.53           | 6.21  | 6.88  | 7.56  | 8.23  | 8.91  |
| U75IR**/90/90 | I/R ** W 90° 900R | 900        | 938 | 938 | 938 | 6.42           | 7.09  | 7.77  | 8.45  | 9.12  | 9.80  |
| U10IR**/90/30 | I/R ** W 90° 300R | 300        | 350 | 350 | 350 | 3.44           | 4.12  | 4.79  | 5.47  | 6.14  | 6.82  |
| U10IR**/90/45 | I/R ** W 90° 450R | 450        | 500 | 500 | 500 | 4.48           | 5.16  | 5.83  | 6.51  | 7.18  | 7.86  |
| U10IR**/90/60 | I/R ** W 90° 600R | 600        | 650 | 650 | 650 | 5.52           | 6.19  | 6.87  | 7.54  | 8.22  | 8.89  |
| U10IR**/90/75 | I/R ** W 90° 750R | 750        | 800 | 800 | 800 | 6.56           | 7.23  | 7.91  | 8.59  | 9.26  | 9.94  |
| U10IR**/90/90 | I/R ** W 90° 900R | 900        | 950 | 950 | 950 | 7.60           | 8.27  | 8.95  | 9.62  | 10.30 | 10.97 |
| U12IR**/90/30 | I/R ** W 90° 300R | 300        | 363 | 363 | 363 | 5.26           | 6.11  | 6.97  | 7.82  | 8.67  | 9.52  |
| U12IR**/90/45 | I/R ** W 90° 450R | 450        | 513 | 513 | 513 | 6.82           | 7.67  | 8.52  | 9.37  | 10.23 | 11.08 |
| U12IR**/90/60 | I/R ** W 90° 600R | 600        | 663 | 663 | 663 | 8.38           | 9.23  | 10.08 | 10.94 | 11.79 | 12.64 |
| U12IR**/90/75 | I/R ** W 90° 750R | 750        | 813 | 813 | 813 | 9.93           | 10.79 | 11.64 | 12.49 | 13.34 | 14.20 |
| U12IR**/90/90 | I/R ** W 90° 900R | 900        | 963 | 963 | 963 | 11.49          | 12.34 | 13.19 | 14.05 | 14.90 | 15.75 |
| U15IR**/90/30 | I/R ** W 90° 300R | 300        | 375 | 375 | 375 | 6.14           | 6.99  | 7.84  | 8.69  | 9.55  | 10.40 |
| U15IR**/90/45 | I/R ** W 90° 450R | 450        | 525 | 525 | 525 | 7.91           | 8.76  | 9.61  | 10.46 | 11.31 | 12.17 |
| U15IR**/90/60 | I/R ** W 90° 600R | 600        | 675 | 675 | 675 | 9.67           | 10.52 | 11.37 | 12.22 | 13.08 | 13.93 |
| U15IR**/90/75 | I/R ** W 90° 750R | 750        | 825 | 825 | 825 | 11.43          | 12.28 | 13.13 | 13.99 | 14.84 | 15.69 |
| U15IR**/90/90 | I/R ** W 90° 900R | 900        | 975 | 975 | 975 | 13.19          | 14.04 | 14.90 | 15.75 | 16.60 | 17.45 |

\*\* Specify Ladder Type +Weights Shown are based on Hot Dip Galvanized - Reduced Weights for Stainless Steel on Request

## Out Side Riser

**Depths :** 50, 75, 100, 125, 150 mm  
**Width :** 150, 300, 450, 600, 750, 900mm  
**Degree :** 30°, 45°, 60°, 90°  
**Radii :** 300, 450, 600, 750, 900 mm

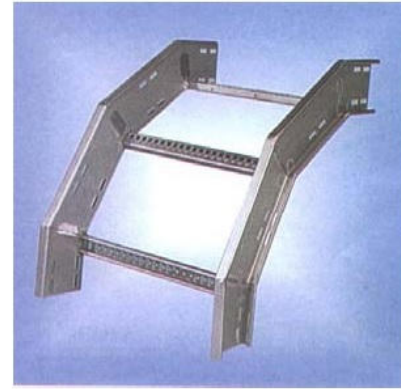

### 30° Outside Riser

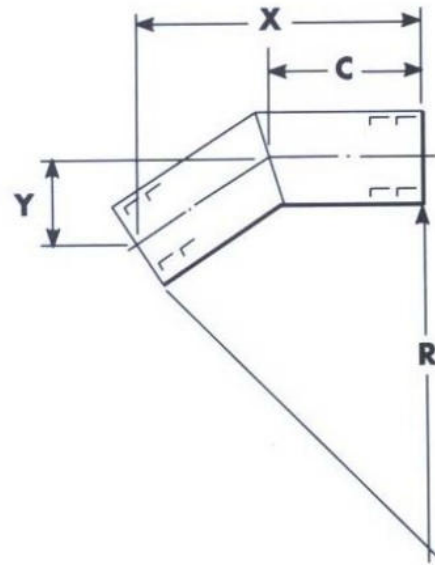
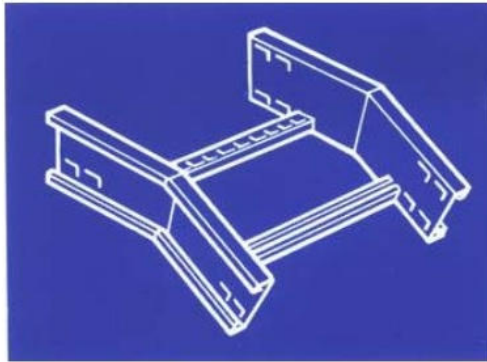

| Part No.      | Description       | Dimensions |     |     |     | Weight ((H) Kg) |      |      |      |      |      |
|---------------|-------------------|------------|-----|-----|-----|-----------------|------|------|------|------|------|
|               |                   | R          | C   | X   | Y   | 150             | 300  | 450  | 600  | 750  | 900  |
| U50R**/30/30  | O/R ** W 30° 300R | 300        | 87  | 163 | 44  | 0.78            | 1.00 | 1.21 | 1.42 |      |      |
| U50R**/30/45  | O/R ** W 30° 450R | 450        | 127 | 238 | 64  |                 |      |      |      |      |      |
| U50R**/30/60  | O/R ** W 30° 600R | 600        | 167 | 313 | 84  |                 |      |      |      |      |      |
| U50R**/30/75  | O/R ** W 30° 750R | 750        | 208 | 388 | 104 |                 |      |      |      |      |      |
| U50R**/30/90  | O/R ** W 30° 900R | 900        | 248 | 463 | 124 |                 |      |      |      |      |      |
| U75R**/30/30  | O/R ** W 30° 300R | 300        | 90  | 169 | 45  |                 |      | 1.75 | 2.09 | 2.43 | 2.76 |
| U75R**/30/45  | O/R ** W 30° 450R | 450        | 131 | 244 | 65  | 1.37            | 1.70 | 2.04 | 2.38 | 2.72 | 3.06 |
| U75R**/30/60  | O/R ** W 30° 600R | 600        | 171 | 319 | 85  | 1.66            | 2.00 | 2.34 | 2.68 | 3.01 | 3.35 |
| U75R**/30/75  | O/R ** W 30° 750R | 750        | 211 | 394 | 106 | 1.96            | 2.29 | 2.63 | 2.97 | 3.31 | 3.65 |
| U75R**/30/90  | O/R ** W 30° 900R | 900        | 251 | 469 | 126 | 2.25            | 2.59 | 2.93 | 3.27 | 3.60 | 3.94 |
| U100R**/30/30 | O/R ** W 30° 300R | 300        | 94  | 175 | 47  | 1.26            | 1.60 | 1.93 | 2.27 | 2.61 | 2.95 |
| U100R**/30/45 | O/R ** W 30° 450R | 450        | 134 | 250 | 67  | 1.61            | 1.95 | 2.28 | 2.62 | 2.96 | 3.30 |
| U100R**/30/60 | O/R ** W 30° 600R | 600        | 174 | 325 | 87  | 1.95            | 2.29 | 2.63 | 2.96 | 3.30 | 3.64 |
| U100R**/30/75 | O/R ** W 30° 750R | 750        | 214 | 400 | 107 | 2.30            | 2.64 | 2.98 | 3.31 | 3.65 | 3.99 |
| U100R**/30/90 | O/R ** W 30° 900R | 900        | 255 | 475 | 127 | 2.64            | 2.98 | 3.32 | 3.66 | 4.00 | 4.33 |
| U120R**/30/30 | O/R ** W 30° 300R | 300        | 97  | 181 | 49  | 1.90            | 2.32 | 2.75 | 3.18 | 3.60 | 4.03 |
| U120R**/30/45 | O/R ** W 30° 450R | 450        | 137 | 256 | 69  | 2.14            | 2.84 | 3.27 | 3.69 | 4.12 | 4.54 |
| U120R**/30/60 | O/R ** W 30° 600R | 600        | 178 | 331 | 89  | 2.94            | 3.36 | 3.79 | 4.22 | 4.64 | 5.07 |
| U120R**/30/75 | O/R ** W 30° 750R | 750        | 218 | 406 | 109 | 3.45            | 3.88 | 4.31 | 4.73 | 5.16 | 5.58 |
| U120R**/30/90 | O/R ** W 30° 900R | 900        | 258 | 481 | 129 | 3.97            | 4.40 | 4.82 | 5.25 | 5.67 | 6.10 |
| U150R**/30/30 | O/R ** W 30° 300R | 300        | 100 | 188 | 50  | 2.19            | 2.61 | 3.04 | 3.47 | 3.89 | 4.32 |
| U150R**/30/45 | O/R ** W 30° 450R | 450        | 141 | 263 | 70  | 2.78            | 3.21 | 3.63 | 4.06 | 4.48 | 4.91 |
| U150R**/30/60 | O/R ** W 30° 600R | 600        | 181 | 338 | 90  | 3.36            | 3.79 | 4.22 | 4.64 | 5.07 | 5.49 |
| U150R**/30/75 | O/R ** W 30° 750R | 750        | 221 | 413 | 111 | 3.95            | 4.38 | 4.80 | 5.23 | 5.65 | 6.08 |
| U150R**/30/90 | O/R ** W 30° 900R | 900        | 261 | 488 | 131 | 4.54            | 4.97 | 5.39 | 5.82 | 6.25 | 6.67 |

\*\* Specify Ladder Type +Weights Shown are based on Hot Dip Galvanized - Reduced Weights for Stainless Steel on Request

## 45° Outside Riser

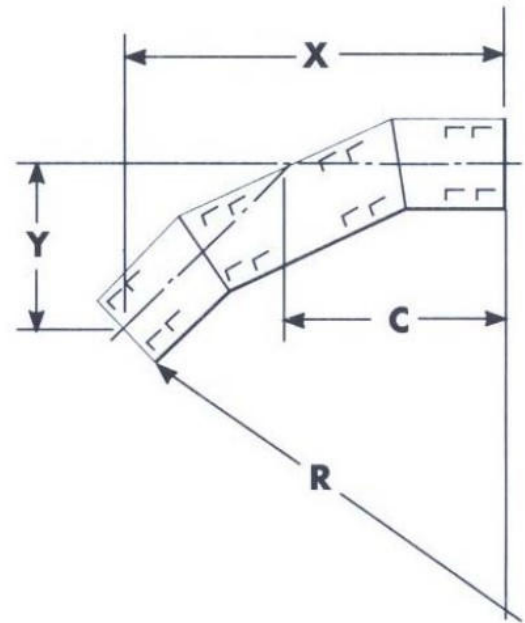
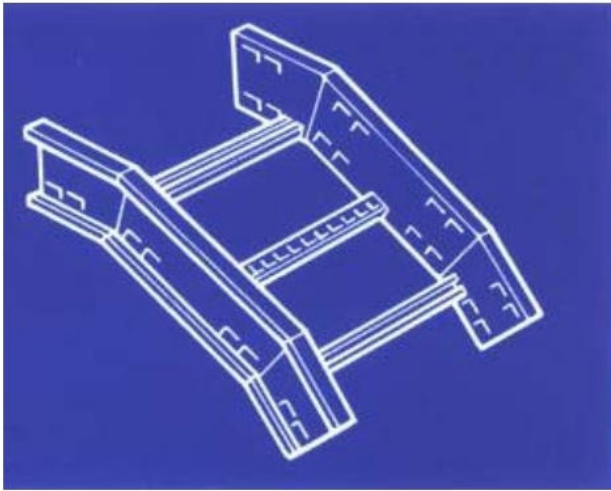

| Part No.      | Description       | Dimensions |     |     |     | Weight ((H <sup>3</sup> ) Kg) |      |      |      |      |      |
|---------------|-------------------|------------|-----|-----|-----|-------------------------------|------|------|------|------|------|
|               |                   | R          | C   | X   | Y   | 150                           | 300  | 450  | 600  | 750  | 900  |
| U500R**/45/30 | O/R ** W 45° 300R | 300        | 155 | 265 | 110 | 1.29                          | 1.61 | 1.93 | 2.25 |      |      |
| U500R**/45/45 | O/R ** W 45° 450R | 450        | 197 | 336 | 139 |                               |      |      |      |      |      |
| U500R**/45/60 | O/R ** W 45° 600R | 600        | 259 | 442 | 183 |                               |      |      |      |      |      |
| U500R**/45/75 | O/R ** W 45° 750R | 750        | 321 | 548 | 227 |                               |      |      |      |      |      |
| U500R**/45/90 | O/R ** W 45° 900R | 900        | 383 | 654 | 271 |                               |      |      |      |      |      |
| U750R**/45/30 | O/R ** W 45° 300R | 300        | 160 | 273 | 113 |                               |      | 2.76 | 3.27 | 3.78 | 4.28 |
| U750R**/45/45 | O/R ** W 45° 450R | 450        | 202 | 345 | 143 | 2.04                          | 2.54 | 3.05 | 3.56 | 4.06 | 4.57 |
| U750R**/45/60 | O/R ** W 45° 600R | 600        | 264 | 451 | 187 | 2.47                          | 2.98 | 3.49 | 3.99 | 4.50 | 5.01 |
| U750R**/45/75 | O/R ** W 45° 750R | 750        | 326 | 557 | 231 | 2.91                          | 3.42 | 3.92 | 4.43 | 4.94 | 5.44 |
| U750R**/45/90 | O/R ** W 45° 900R | 900        | 388 | 663 | 275 | 3.35                          | 3.86 | 4.36 | 4.87 | 5.38 | 5.88 |
| U100R**/45/30 | O/R ** W 45° 300R | 300        | 165 | 282 | 117 | 2.05                          | 2.56 | 3.07 | 3.57 | 4.08 | 4.59 |
| U100R**/45/45 | O/R ** W 45° 450R | 450        | 207 | 354 | 146 | 2.39                          | 2.90 | 3.40 | 3.91 | 4.42 | 4.93 |
| U100R**/45/60 | O/R ** W 45° 600R | 600        | 269 | 460 | 190 | 2.90                          | 3.41 | 3.92 | 4.42 | 4.93 | 5.44 |
| U100R**/45/75 | O/R ** W 45° 750R | 750        | 331 | 566 | 234 | 3.42                          | 3.92 | 4.43 | 4.94 | 5.44 | 5.95 |
| U100R**/45/90 | O/R ** W 45° 900R | 900        | 394 | 672 | 278 | 3.93                          | 4.44 | 4.95 | 5.45 | 5.96 | 6.47 |
| U120R**/45/30 | O/R ** W 45° 300R | 300        | 170 | 291 | 121 | 3.09                          | 3.72 | 4.36 | 5.00 | 5.64 | 6.28 |
| U120R**/45/45 | O/R ** W 45° 450R | 450        | 212 | 362 | 150 | 3.59                          | 4.23 | 4.87 | 5.51 | 6.15 | 6.78 |
| U120R**/45/60 | O/R ** W 45° 600R | 600        | 274 | 468 | 194 | 4.36                          | 5.00 | 5.64 | 6.28 | 6.92 | 7.56 |
| U120R**/45/75 | O/R ** W 45° 750R | 750        | 337 | 575 | 238 | 5.13                          | 5.77 | 6.41 | 7.05 | 7.69 | 8.33 |
| U120R**/45/90 | O/R ** W 45° 900R | 900        | 399 | 681 | 282 | 5.91                          | 6.55 | 7.18 | 7.82 | 8.46 | 9.10 |
| U150R**/45/30 | O/R ** W 45° 300R | 300        | 176 | 300 | 124 | 3.56                          | 4.19 | 4.83 | 5.47 | 6.11 | 6.75 |
| U150R**/45/45 | O/R ** W 45° 450R | 450        | 217 | 371 | 154 | 4.13                          | 4.76 | 5.40 | 6.04 | 6.69 | 7.32 |
| U150R**/45/60 | O/R ** W 45° 600R | 600        | 280 | 477 | 198 | 5.00                          | 5.64 | 6.28 | 6.92 | 7.56 | 8.20 |
| U150R**/45/75 | O/R ** W 45° 750R | 750        | 342 | 583 | 242 | 5.87                          | 6.51 | 7.15 | 7.79 | 8.43 | 9.07 |
| U150R**/45/90 | O/R ** W 45° 900R | 900        | 404 | 689 | 286 | 6.74                          | 7.38 | 8.02 | 8.66 | 9.30 | 9.94 |

\*\* Specify Ladder Type +Weights Shown are based on Hot Dip Galvanized - Reduced Weights for Stainless Steel on Request

## 60° Outside Riser

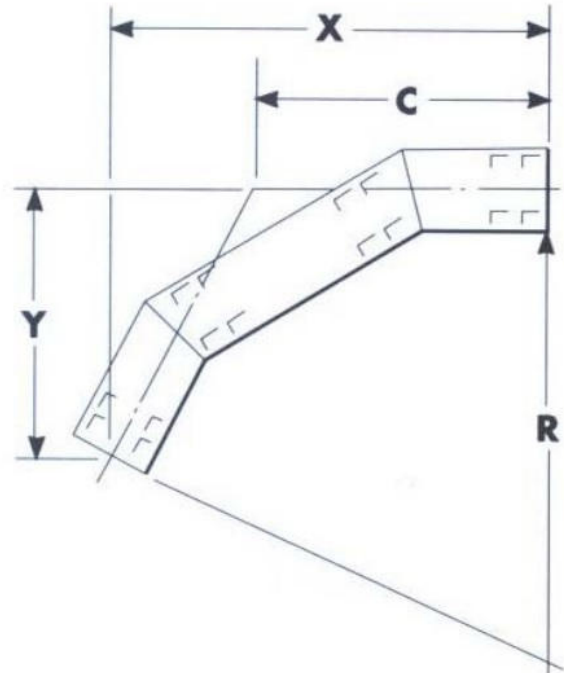
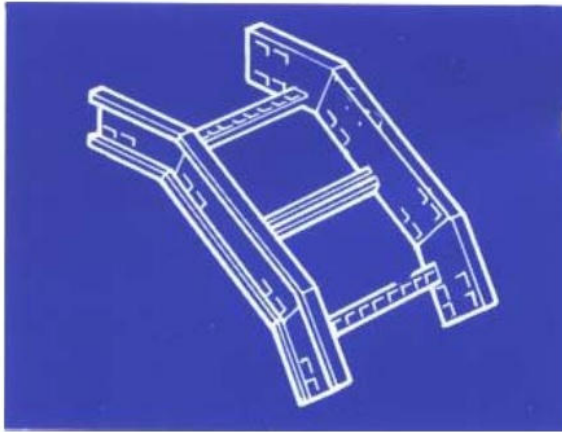

| Part No.      | Description       | Dimensions |     |     |     | Weight ((Ht) Kg) |      |       |       |       |       |
|---------------|-------------------|------------|-----|-----|-----|------------------|------|-------|-------|-------|-------|
|               |                   | R          | C   | X   | Y   | 150              | 300  | 450   | 600   | 750   | 900   |
| U50OR**/60/30 | O/R ** W 60° 300R | 300        | 188 | 281 | 163 | 1.45             | 1.78 | 2.10  | 2.42  |       |       |
| U50OR**/60/45 | O/R ** W 60° 450R | 450        | 274 | 411 | 238 |                  |      |       |       |       |       |
| U50OR**/60/60 | O/R ** W 60° 600R | 600        | 361 | 541 | 313 |                  |      |       |       |       |       |
| U50OR**/60/75 | O/R ** W 60° 750R | 750        | 447 | 671 | 388 |                  |      |       |       |       |       |
| U50OR**/60/90 | O/R ** W 60° 900R | 900        | 534 | 801 | 463 |                  |      |       |       |       |       |
| U75OR**/60/30 | O/R ** W 60° 300R | 300        | 195 | 292 | 169 |                  |      | 2.99  | 3.50  | 4.01  | 4.51  |
| U75OR**/60/45 | O/R ** W 60° 450R | 450        | 281 | 422 | 244 | 2.57             | 3.08 | 3.58  | 4.09  | 4.60  | 5.10  |
| U75OR**/60/60 | O/R ** W 60° 600R | 600        | 368 | 522 | 319 | 3.15             | 3.66 | 4.17  | 4.67  | 5.18  | 5.69  |
| U75OR**/60/75 | O/R ** W 60° 750R | 750        | 455 | 682 | 394 | 3.74             | 4.25 | 4.76  | 5.26  | 5.77  | 6.28  |
| U75OR**/60/90 | O/R ** W 60° 900R | 900        | 541 | 812 | 469 | 4.33             | 4.84 | 5.35  | 5.85  | 6.36  | 6.87  |
| U100R**/60/30 | O/R ** W 60° 300R | 300        | 202 | 303 | 175 | 2.35             | 2.86 | 3.37  | 3.87  | 4.38  | 4.89  |
| U100R**/60/45 | O/R ** W 60° 450R | 450        | 289 | 433 | 250 | 3.04             | 3.55 | 4.05  | 4.56  | 5.07  | 5.57  |
| U100R**/60/60 | O/R ** W 60° 600R | 600        | 375 | 563 | 325 | 3.73             | 4.24 | 4.75  | 5.25  | 5.76  | 6.27  |
| U100R**/60/75 | O/R ** W 60° 750R | 750        | 462 | 693 | 400 | 4.43             | 4.93 | 5.44  | 5.95  | 6.45  | 6.96  |
| U100R**/60/90 | O/R ** W 60° 900R | 900        | 548 | 832 | 475 | 5.12             | 5.63 | 6.13  | 6.64  | 7.15  | 7.65  |
| U120R**/60/30 | O/R ** W 60° 300R | 300        | 209 | 314 | 181 | 3.58             | 4.22 | 4.86  | 5.50  | 6.14  | 6.78  |
| U120R**/60/45 | O/R ** W 60° 450R | 450        | 296 | 444 | 256 | 4.62             | 5.25 | 5.89  | 6.53  | 7.17  | 7.81  |
| U120R**/60/60 | O/R ** W 60° 600R | 600        | 382 | 574 | 331 | 5.65             | 6.29 | 6.93  | 7.57  | 8.21  | 8.85  |
| U120R**/60/75 | O/R ** W 60° 750R | 750        | 469 | 704 | 406 | 6.69             | 7.33 | 7.97  | 8.61  | 9.25  | 9.89  |
| U120R**/60/90 | O/R ** W 60° 900R | 900        | 556 | 834 | 481 | 7.73             | 8.37 | 9.01  | 9.65  | 10.29 | 10.93 |
| U150R**/60/30 | O/R ** W 60° 300R | 300        | 217 | 325 | 188 | 4.16             | 4.80 | 5.44  | 6.08  | 6.72  | 7.36  |
| U150R**/60/45 | O/R ** W 60° 450R | 450        | 303 | 455 | 263 | 5.34             | 5.98 | 6.62  | 7.26  | 7.90  | 8.53  |
| U150R**/60/60 | O/R ** W 60° 600R | 600        | 390 | 585 | 338 | 6.52             | 7.16 | 7.79  | 8.43  | 9.07  | 9.71  |
| U150R**/60/75 | O/R ** W 60° 750R | 750        | 476 | 714 | 413 | 7.69             | 8.33 | 8.97  | 9.61  | 10.25 | 10.89 |
| U150R**/60/90 | O/R ** W 60° 900R | 900        | 563 | 844 | 488 | 8.86             | 9.50 | 10.14 | 10.78 | 11.42 | 12.06 |

\*\* Specify Ladder Type +Weights Shown are based on Hot Dip Galvanized - Reduced Weights for Stainless Steel on Request

## 90° Outside Riser

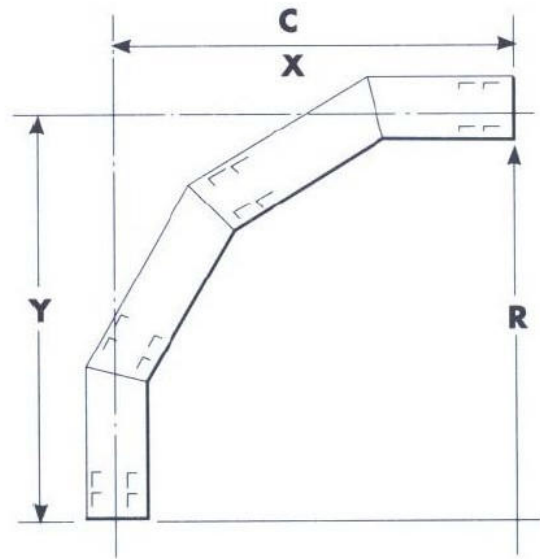
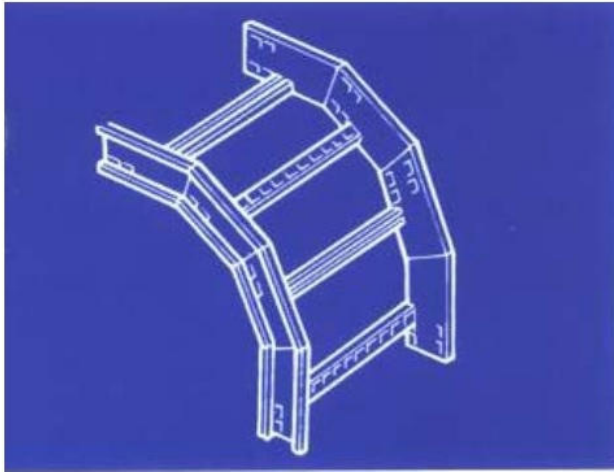

| Part No.      | Description       | Dimensions |     |     |     |       | Weight (Ht.) Kg |       |       |       |       |  |
|---------------|-------------------|------------|-----|-----|-----|-------|-----------------|-------|-------|-------|-------|--|
|               |                   | R          | C   | X   | Y   | 150   | 300             | 450   | 600   | 750   | 900   |  |
| U500R**/90/30 | O/R ** W 90° 300R | 300        | 325 | 325 | 325 | 2.13  | 2.56            | 2.99  | 3.41  |       |       |  |
| U500R**/90/45 | O/R ** W 90° 450R | 450        | 475 | 475 | 475 |       |                 |       |       |       |       |  |
| U500R**/90/60 | O/R ** W 90° 600R | 600        | 625 | 625 | 625 |       |                 |       |       |       |       |  |
| U500R**/90/75 | O/R ** W 90° 750R | 750        | 775 | 775 | 775 |       |                 |       |       |       |       |  |
| U500R**/90/90 | O/R ** W 90° 900R | 900        | 925 | 925 | 925 |       |                 |       |       |       |       |  |
| U750R**/90/30 | O/R ** W 90° 300R | 300        | 338 | 338 | 338 |       |                 | 4.24  | 4.91  | 5.59  | 6.26  |  |
| U750R**/90/45 | O/R ** W 90° 450R | 450        | 488 | 488 | 488 | 3.77  | 4.44            | 5.12  | 5.79  | 6.47  | 7.14  |  |
| U750R**/90/60 | O/R ** W 90° 600R | 600        | 638 | 638 | 638 | 4.65  | 5.32            | 6.00  | 6.68  | 7.35  | 8.03  |  |
| U750R**/90/75 | O/R ** W 90° 750R | 750        | 788 | 788 | 788 | 5.53  | 6.21            | 6.88  | 7.56  | 8.23  | 8.91  |  |
| U750R**/90/90 | O/R ** W 90° 900R | 900        | 938 | 938 | 938 | 6.42  | 7.09            | 7.77  | 8.45  | 9.12  | 9.80  |  |
| U100R**/90/30 | O/R ** W 90° 300R | 300        | 350 | 350 | 350 | 3.44  | 4.12            | 4.79  | 5.47  | 6.14  | 6.82  |  |
| U100R**/90/45 | O/R ** W 90° 450R | 450        | 500 | 500 | 500 | 4.48  | 5.16            | 5.83  | 6.51  | 7.18  | 7.86  |  |
| U100R**/90/60 | O/R ** W 90° 600R | 600        | 650 | 650 | 650 | 5.52  | 6.19            | 6.87  | 7.54  | 8.22  | 8.89  |  |
| U100R**/90/75 | O/R ** W 90° 750R | 750        | 800 | 800 | 800 | 6.56  | 7.23            | 7.91  | 8.59  | 9.26  | 9.94  |  |
| U100R**/90/90 | O/R ** W 90° 900R | 900        | 950 | 950 | 950 | 7.60  | 8.27            | 8.95  | 9.62  | 10.30 | 10.97 |  |
| U120R**/90/30 | O/R ** W 90° 300R | 300        | 363 | 363 | 363 | 5.26  | 6.11            | 6.97  | 7.82  | 8.67  | 9.52  |  |
| U120R**/90/45 | O/R ** W 90° 450R | 450        | 513 | 513 | 513 | 6.82  | 7.67            | 8.52  | 9.37  | 10.23 | 11.08 |  |
| U120R**/90/60 | O/R ** W 90° 600R | 600        | 663 | 663 | 663 | 8.38  | 9.23            | 10.08 | 10.94 | 11.79 | 12.64 |  |
| U120R**/90/75 | O/R ** W 90° 750R | 750        | 813 | 813 | 813 | 9.93  | 10.79           | 11.64 | 12.49 | 13.34 | 14.20 |  |
| U120R**/90/90 | O/R ** W 90° 900R | 900        | 963 | 963 | 963 | 11.49 | 12.34           | 13.19 | 14.05 | 14.90 | 15.75 |  |
| U150R**/90/30 | O/R ** W 90° 300R | 300        | 375 | 375 | 375 | 6.14  | 6.99            | 7.84  | 8.69  | 9.55  | 10.40 |  |
| U150R**/90/45 | O/R ** W 90° 450R | 450        | 525 | 525 | 525 | 7.91  | 8.76            | 9.61  | 10.46 | 11.31 | 12.17 |  |
| U150R**/90/60 | O/R ** W 90° 600R | 600        | 675 | 675 | 675 | 9.67  | 10.52           | 11.37 | 12.22 | 13.08 | 13.93 |  |
| U150R**/90/75 | O/R ** W 90° 750R | 750        | 825 | 825 | 825 | 11.43 | 12.28           | 13.13 | 13.99 | 14.84 | 15.69 |  |
| U150R**/90/90 | O/R ** W 90° 900R | 900        | 975 | 975 | 975 | 13.19 | 14.04           | 14.90 | 15.75 | 16.60 | 17.45 |  |

\*\* Specify Ladder Type +Weights Shown are based on Hot Dip Galvanized - Reduced Weights for Stainless Steel on Request

## Left / Right Reducer

**Depths :** 50, 75, 100, 125, 150 mm  
**Width (1) :** 300, 450, 600, 750, 900 mm  
**Width (2) :** 150, 300, 450, 600, 750mm

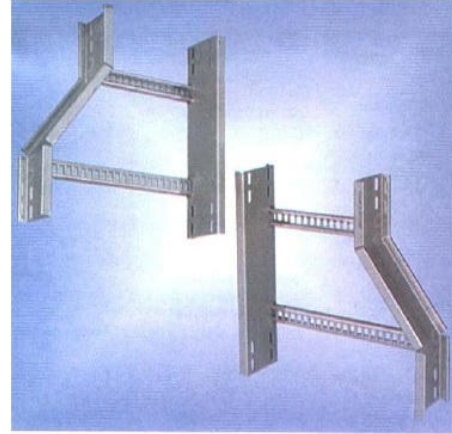

### Left Hand Reducer

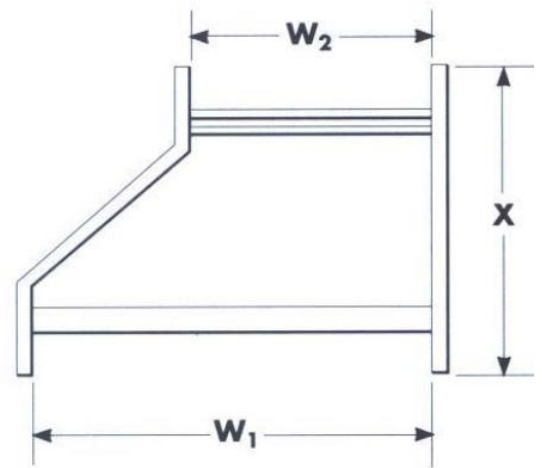
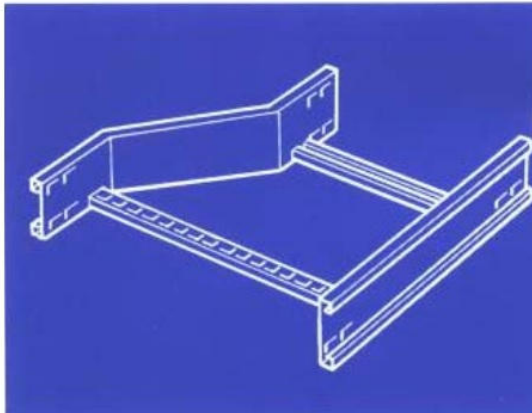

| Part No.   | Description     | Dimensions |     |     | Weight (H <sub>1</sub> ) Kg |      |      |      |     |
|------------|-----------------|------------|-----|-----|-----------------------------|------|------|------|-----|
|            |                 | W1         | W2  | X   | U50                         | U75  | U10  | U12  | U15 |
| U**LR30/15 | L/H/RED 300-150 | 300        | 150 | 500 | 2.43                        | 2.77 | 4.03 | 4.48 |     |
| U**LR45/15 | L/H/RED 450-150 | 450        | 150 | 500 | 2.80                        | 3.17 | 4.60 | 5.10 |     |
| U**LR45/30 | L/H/RED 450-300 | 450        | 300 | 500 | 2.77                        | 3.10 | 4.45 | 4.90 |     |
| U**LR60/15 | L/H/RED 600-150 | 600        | 150 | 500 | 3.21                        | 3.62 | 5.24 | 5.79 |     |
| U**LR60/30 | L/H/RED 600-300 | 600        | 300 | 500 | 3.14                        | 3.51 | 5.03 | 5.52 |     |
| U**LR60/45 | L/H/RED 600-450 | 600        | 450 | 500 | 3.11                        | 3.44 | 4.88 | 5.33 |     |
| U**LR75/15 | L/H/RED 750-150 | 750        | 150 | 500 | 3.64                        | 4.09 | 5.90 | 6.51 |     |
| U**LR75/30 | L/H/RED 750-300 | 750        | 300 | 500 | 3.55                        | 3.96 | 5.66 | 6.21 |     |
| U**LR75/45 | L/H/RED 750-450 | 750        | 450 | 500 | 3.48                        | 3.85 | 5.45 | 5.95 |     |
| U**LR75/60 | L/H/RED 750-600 | 750        | 600 | 500 | 3.44                        | 3.78 | 5.31 | 5.75 |     |
| U**LR90/15 | L/H/RED 900-150 | 900        | 150 | 500 | 4.07                        | 4.57 | 6.58 | 7.25 |     |
| U**LR90/30 | L/H/RED 900-300 | 900        | 300 | 500 | 3.97                        | 4.43 | 6.33 | 6.94 |     |
| U**LR90/45 | L/H/RED 900-450 | 900        | 450 | 500 | 3.89                        | 4.30 | 6.09 | 6.64 |     |
| U**LR90/60 | L/H/RED 900-600 | 900        | 600 | 500 | 3.82                        | 4.19 | 5.88 | 6.37 |     |
| U**LR90/75 | L/H/RED 900-750 | 900        | 750 | 500 | 3.78                        | 4.12 | 5.73 | 6.18 |     |

\*\* Specify Ladder Type +Weights Shown are based on Hot Dip Galvanized - Reduced Weights for Stainless Steel on Request

## Right Hand Reducer

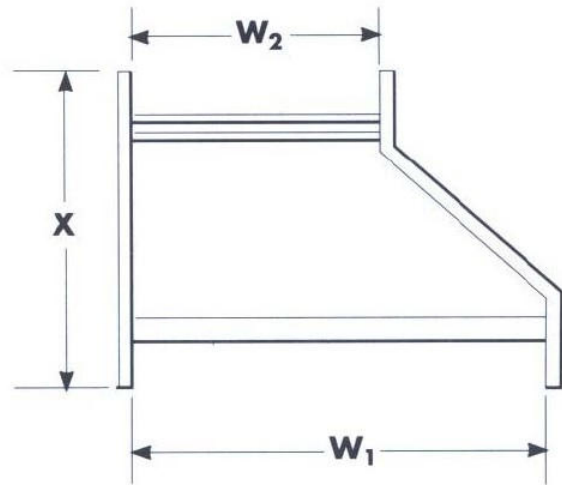
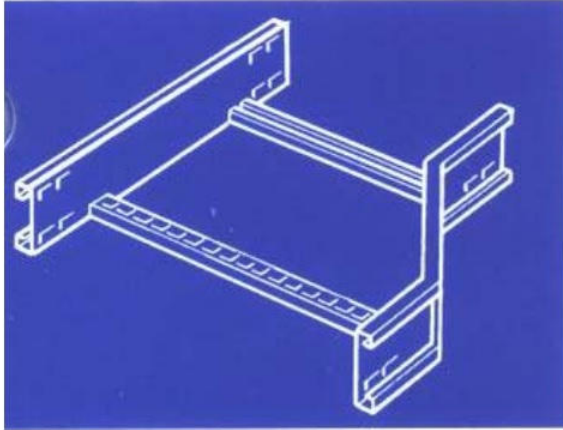

| Part No.   | Description     | Dimensions |     |     | Weight ((H <sup>1</sup> ) Kg) |      |      |      |      |
|------------|-----------------|------------|-----|-----|-------------------------------|------|------|------|------|
|            |                 | W1         | W2  | X   | U50                           | U75  | U10  | U12  | U15  |
| U**RR30/15 | R/H/RED 300-150 | 300        | 150 | 500 |                               | 2.43 | 2.77 | 4.03 | 4.48 |
| U**RR45/15 | R/H/RED 450-150 | 450        | 150 | 500 |                               | 2.80 | 3.17 | 4.60 | 5.10 |
| U**RR45/30 | R/H/RED 450-300 | 450        | 300 | 500 |                               | 2.77 | 3.10 | 4.45 | 4.90 |
| U**RR60/15 | R/H/RED 600-150 | 600        | 150 | 500 |                               | 3.21 | 3.62 | 5.24 | 5.79 |
| U**RR60/30 | R/H/RED 600-300 | 600        | 300 | 500 |                               | 3.14 | 3.51 | 5.03 | 5.52 |
| U**RR60/45 | R/H/RED 600-450 | 600        | 450 | 500 |                               | 3.11 | 3.44 | 4.88 | 5.33 |
| U**RR75/15 | R/H/RED 750-150 | 750        | 150 | 500 |                               | 3.64 | 4.09 | 5.90 | 6.51 |
| U**RR75/30 | R/H/RED 750-300 | 750        | 300 | 500 |                               | 3.55 | 3.96 | 5.66 | 6.21 |
| U**RR75/45 | R/H/RED 750-450 | 750        | 450 | 500 |                               | 3.48 | 3.85 | 5.45 | 5.95 |
| U**RR75/60 | R/H/RED 750-600 | 750        | 600 | 500 |                               | 3.44 | 3.78 | 5.31 | 5.75 |
| U**RR90/15 | R/H/RED 900-150 | 900        | 150 | 500 |                               | 4.07 | 4.57 | 6.58 | 7.25 |
| U**RR90/30 | R/H/RED 900-300 | 900        | 300 | 500 |                               | 3.97 | 4.43 | 6.33 | 6.94 |
| U**RR90/45 | R/H/RED 900-450 | 900        | 450 | 500 |                               | 3.89 | 4.30 | 6.09 | 6.64 |
| U**RR90/60 | R/H/RED 900-600 | 900        | 600 | 500 |                               | 3.82 | 4.19 | 5.88 | 6.37 |
| U**RR90/75 | R/H/RED 900-750 | 900        | 750 | 500 |                               | 3.78 | 4.12 | 5.73 | 6.18 |

\*\* Specify Ladder Type +Weights Shown are based on Hot Dip Galvanized - Reduced Weights for Stainless Steel on Request

## Straight Reducer

**Depths :** 50, 75, 100, 125, 150 mm  
**Width (1) :** 300, 450, 600, 750, 900 mm  
**Width (2) :** 150, 300, 450, 600, 750mm

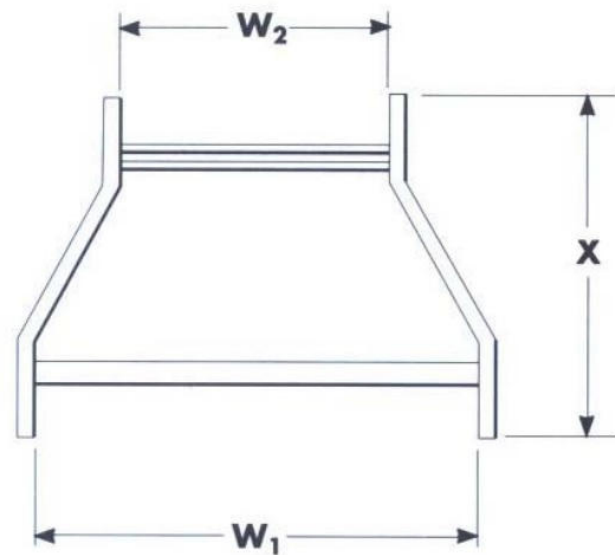
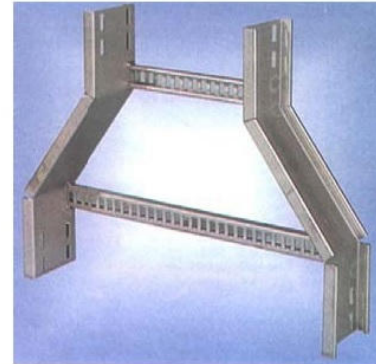
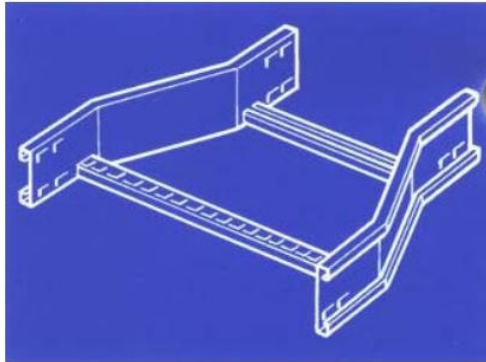

| Part No.   | Description    | Dimensions |     |     | Weight ((Ht) Kg) |      |      |      |      |
|------------|----------------|------------|-----|-----|------------------|------|------|------|------|
|            |                | W1         | W2  | X   | U50              | U75  | U10  | U12  | U15  |
| U**SR30/15 | ST/RED 300-150 | 300        | 150 | 500 |                  | 2.39 | 2.72 | 3.96 | 4.40 |
| U**SR45/15 | ST/RED 450-150 | 450        | 150 | 500 |                  | 2.69 | 3.04 | 4.40 | 4.87 |
| U**SR45/30 | ST/RED 450-300 | 450        | 300 | 500 |                  | 2.73 | 3.06 | 4.38 | 4.82 |
| U**SR60/15 | ST/RED 600-150 | 600        | 150 | 500 |                  | 3.05 | 3.43 | 4.94 | 5.46 |
| U**SR60/30 | ST/RED 600-300 | 600        | 300 | 500 |                  | 3.03 | 3.38 | 4.83 | 5.30 |
| U**SR60/45 | ST/RED 600-450 | 600        | 450 | 500 |                  | 3.06 | 3.39 | 4.81 | 5.25 |
| U**SR75/15 | ST/RED 750-150 | 750        | 150 | 500 |                  | 3.43 | 3.86 | 5.55 | 6.11 |
| U**SR75/30 | ST/RED 750-300 | 750        | 300 | 500 |                  | 3.38 | 3.77 | 5.37 | 5.88 |
| U**SR75/45 | ST/RED 750-450 | 750        | 450 | 500 |                  | 3.37 | 3.72 | 5.25 | 5.72 |
| U**SR75/60 | ST/RED 750-600 | 750        | 600 | 500 |                  | 3.40 | 3.73 | 5.24 | 5.67 |
| U**SR90/15 | ST/RED 900-150 | 900        | 150 | 500 |                  | 3.84 | 4.30 | 6.17 | 6.79 |
| U**SR90/30 | ST/RED 900-300 | 900        | 300 | 500 |                  | 3.77 | 4.20 | 5.97 | 6.54 |
| U**SR90/45 | ST/RED 900-450 | 900        | 450 | 500 |                  | 3.72 | 4.11 | 5.80 | 6.31 |
| U**SR90/60 | ST/RED 900-600 | 900        | 600 | 500 |                  | 3.70 | 4.06 | 5.68 | 6.15 |
| U**SR90/75 | ST/RED 900-750 | 900        | 750 | 500 |                  | 3.74 | 4.07 | 5.66 | 6.10 |

\*\* Specify Ladder Type +Weights Shown are based on Hot Dip Galvanized - Reduced Weights for Stainless Steel on Request

**Accessories**

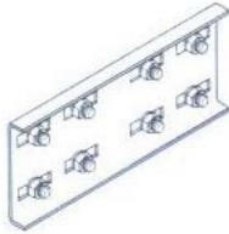

**Side Rail Splice**

U50/SP/(H or S)  
U75/SP/(H or S)  
U10/SP/(H or S)  
U12/SP/(H or S)  
U15/SP/(H or S)  
Supplied in pairs complete with nuts, bolts & washers

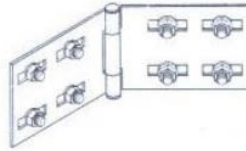

**Horizontal Splice Plate**

U50/HSP/(H or S)  
U75/HSP/(H or S)  
U10/HSP/(H or S)  
U12/HSP/(H or S)  
U15/HSP/(H or S)  
Supplied in pairs complete with nuts, bolts & washers

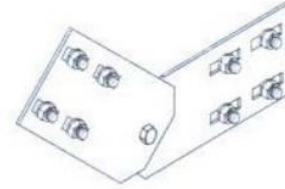

**Vertical Splice Plate**

U50/VSP/(H or S)  
U75/VSP/(H or S)  
U10/VSP/(H or S)  
U12/VSP/(H or S)  
U15/VSP/(H or S)  
Supplied in pairs complete with nuts, bolts & washers



**Universal Clip**

U/CLIP/(H or S)



**Universal Clamp**

U/Clamp/ (H or S)  
Complete with clamp to Ladder fixing



**Side Rail Clamp**

U/HDC/(H or S)



**Hold Down Bracket**

U50/HDB/(H or S)  
U75/HDB/(H or S)  
U10/HDB/(H or S)  
U12/HDB/(H or S)  
U15/HDB/(H or S)



**Suspension Clip**

U50/SC/(H or S)  
U75/SC/(H or S)  
U10/SC/(H or S)  
U12/SC/(H or S)  
U15/SC/(H or S)

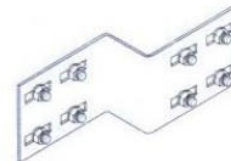

**Reducer Splice**

U\*\*/RSP75/(H or Ladder Type)  
U\*\*/RSP150/(H or S)  
U\*\*/RSP225/(H or S)  
U\*\*/RSP300/(H or S)  
U\*\*/RSP375/(H or S)  
U\*\*/RSP450/(H or S)  
U\*\*/RSP600/(H or S)  
Supplied in pairs complete with nuts, bolts & washers  
\*\* Specify Ladder Type

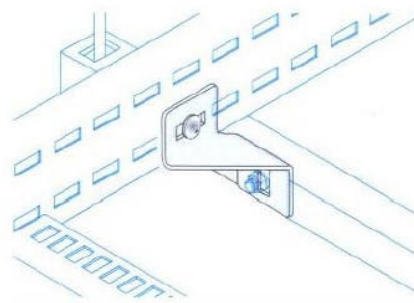

### Angle Clamp

U/Angle/ (H or S)

Complete with nuts, bolts & Washers

\* M10 support fixings to be ordered separately.

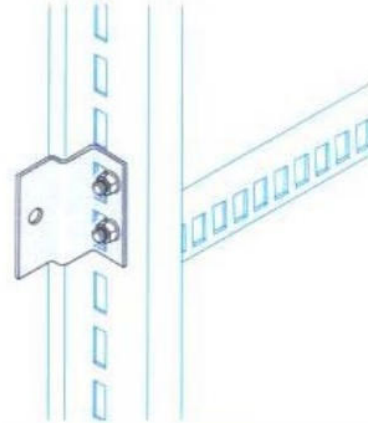

### Wall / Suspension Brackets

U/WCH/(H or S)

Complete with nuts, bolts and washers

\* M12 support fixings to be ordered separately.

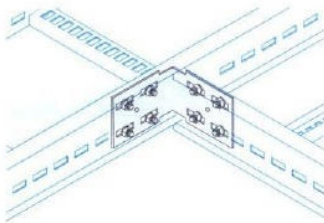

### Tee Bracket

U \*\*/ TB90/(H or S)

Supplied in pairs complete with nuts, bolts and washers

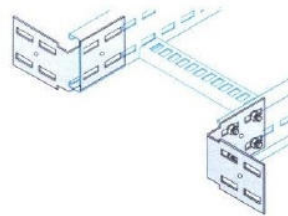

### 90° End Connector

U\*\*/ TB90/ (H or S)

Supplied in pairs complete with nuts, bolts and washers.

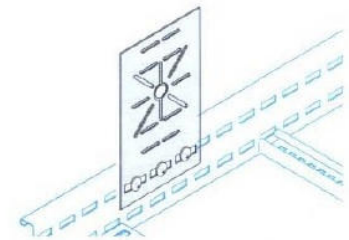

### Mounting Plate

U/MP/(H or S)

Complete with nuts, bolts and washers

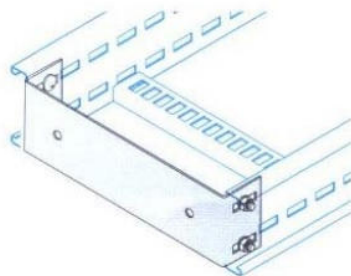

### Stop End

|            |                    |
|------------|--------------------|
| 150mm Wide | U**/SE150/(H or S) |
| 300mm Wide | U**/SE300/(H or S) |
| 450mm Wide | U**/SE450/(H or S) |
| 600mm Wide | U**/SE600/(H or S) |
| 750mm Wide | U**/SE750/(H or S) |
| 900mm Wide | U**/SE900/(H or S) |

Complete with nuts, bolts & Washers

\*\* Specify Ladder Type

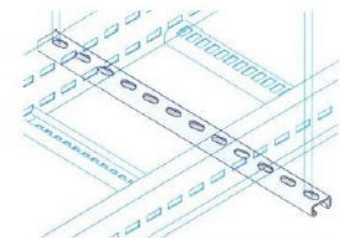

### Stop End

|            |                  |
|------------|------------------|
| 150mm Wide | U/TH150/(H or S) |
| 300mm Wide | U/TH300/(H or S) |
| 450mm Wide | U/TH450/(H or S) |
| 600mm Wide | U/TH600/(H or S) |
| 750mm Wide | U/TH750/(H or S) |
| 900mm Wide | U/TH900/(H or S) |

\*\* M10 support fixings to be ordered separately

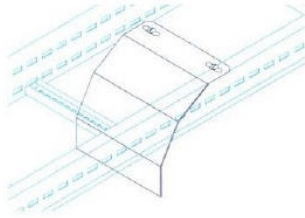

### Universal Dropout

145mm wide U/DO/200 / (H or S)  
 195mm wide U/DO/200 / (H or S)  
 295mm wide U/DO/300 / (H or S)  
 Complete with nuts, bolts & washers

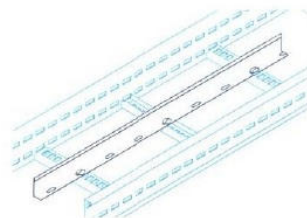

### Straight Divider

30mm high U/DIV30/ (H or S)  
 70mm high U/DIV70/ (H or S)  
 Supplied in 1500 mm lengths.  
 Complete with nuts, bolts & washers.

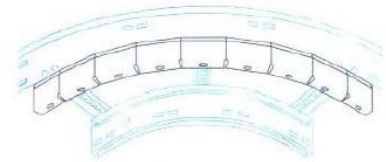

### Curved Divider

30mm high U/CUR30/ (H or S)  
 70mm high U/CUR70/ (H or S)  
 Supplied in 1500 mm lengths.  
 Complete with nuts, bolts and washers.



### Bonding Jumper

CHI-C AWG 1/0 copper wire 15 1/2“(394 mm) long overall  
 CHI-4C AWG 4/0 copper wire 15 1/2“(394 mm) long overall  
 Note : 15 1/2“(394mm) long – no hardware supplied.

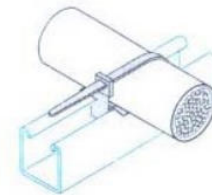

### Cable Tie

NCT 75TB  
 Material : Black Nylon

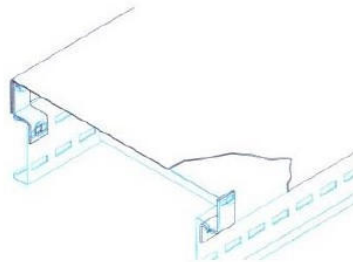

### Cover

150mm wide U/COV 150 (H or S)  
 300mm wide U/COV 300 (H or S)  
 450mm wide U/COV 450 (H or S)  
 600mm wide U/COV 600 (H or S)  
 750mm wide U/COV 750 (H or S)  
 900mm wide U/COV 900 (H or S)

Supplied in 150mm lengths.  
 Complete with clips && fixings  
 Other widths up to 150 mm wide are available in order

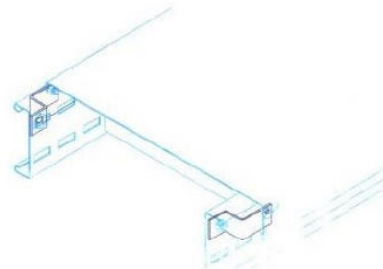

### Cover Clip

U/COV/CLIP (H or S)  
 Cover clips can be used to provide Ventilated or Closed Cover positions as illustrated.

**Load Test Data**

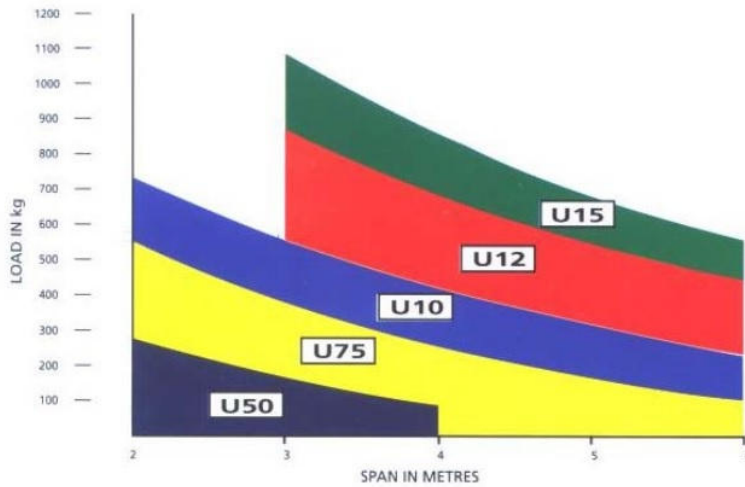

**Multi-Span Testing**

Use the selector chart to determine the appropriate Ladder Duty.

**U50 Ladder**

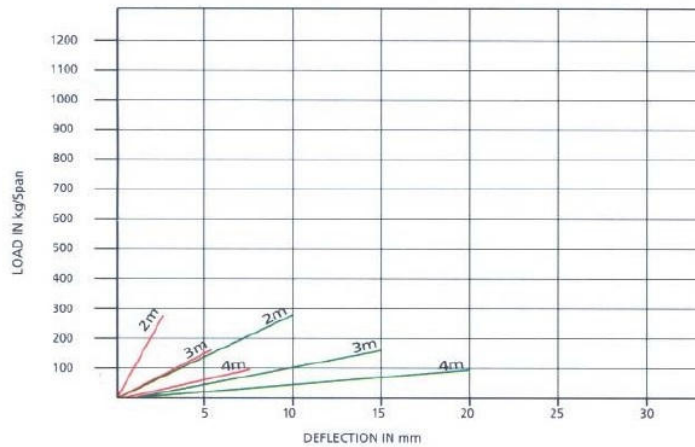

**U75 Ladder**

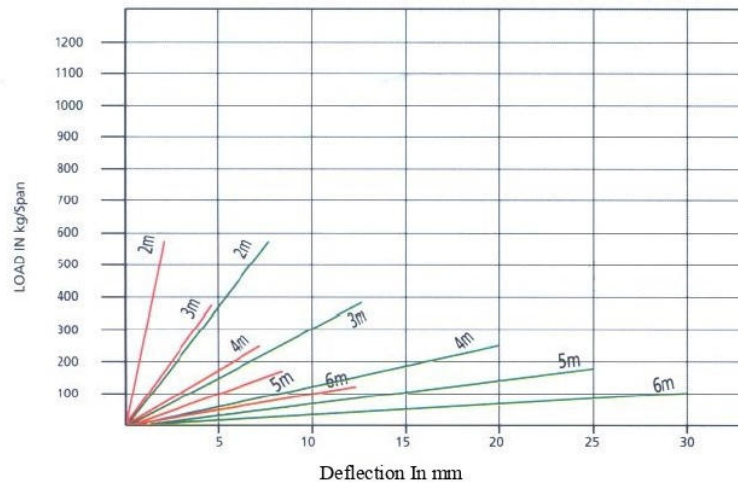

## U10 Ladder

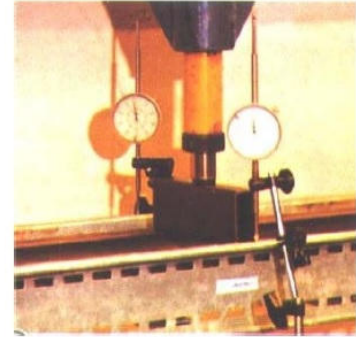
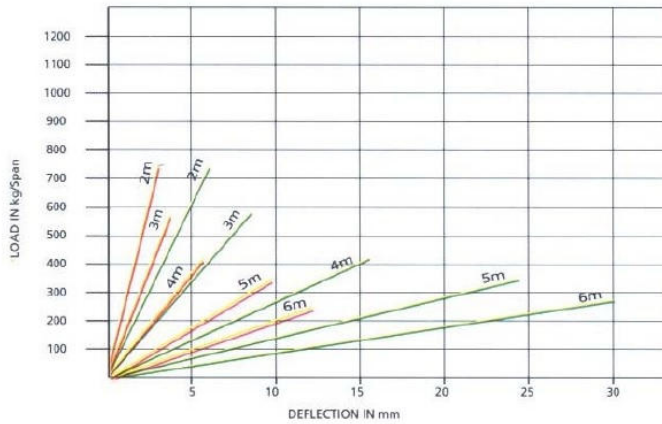

**Deflection Testing**

## U12 Ladder

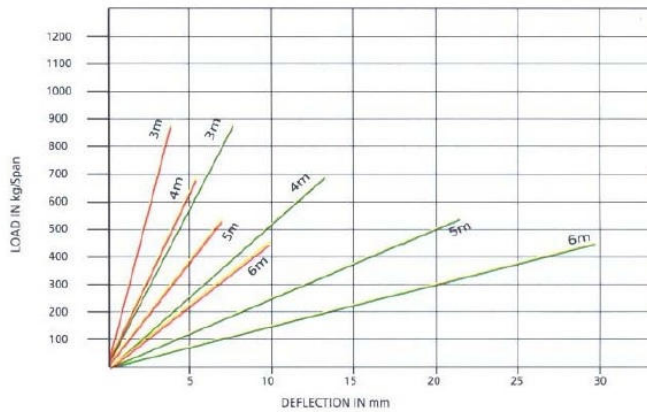

## U15 Ladder

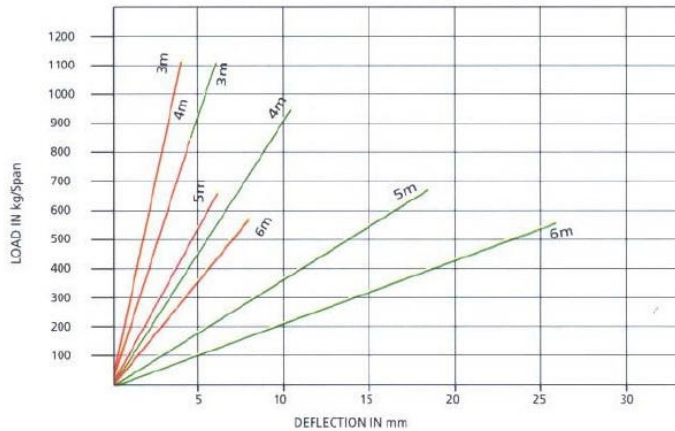

Loading Data Values are from tests using Mild Steel Cable Ladder. Varying results will be shown from other materials, e.g. Stainless Steel. The upper limits give a safety factor in excess of two.

Every care is taken in the testing of materials and products & data given is done so in good faith, but it does not constitute any guarantee or place any liability on us.

— Centre span of a multi-span installation.

— End span of a multi-span installation.



# AB-COPE RUNWAY

# 13

## Cable Runway System

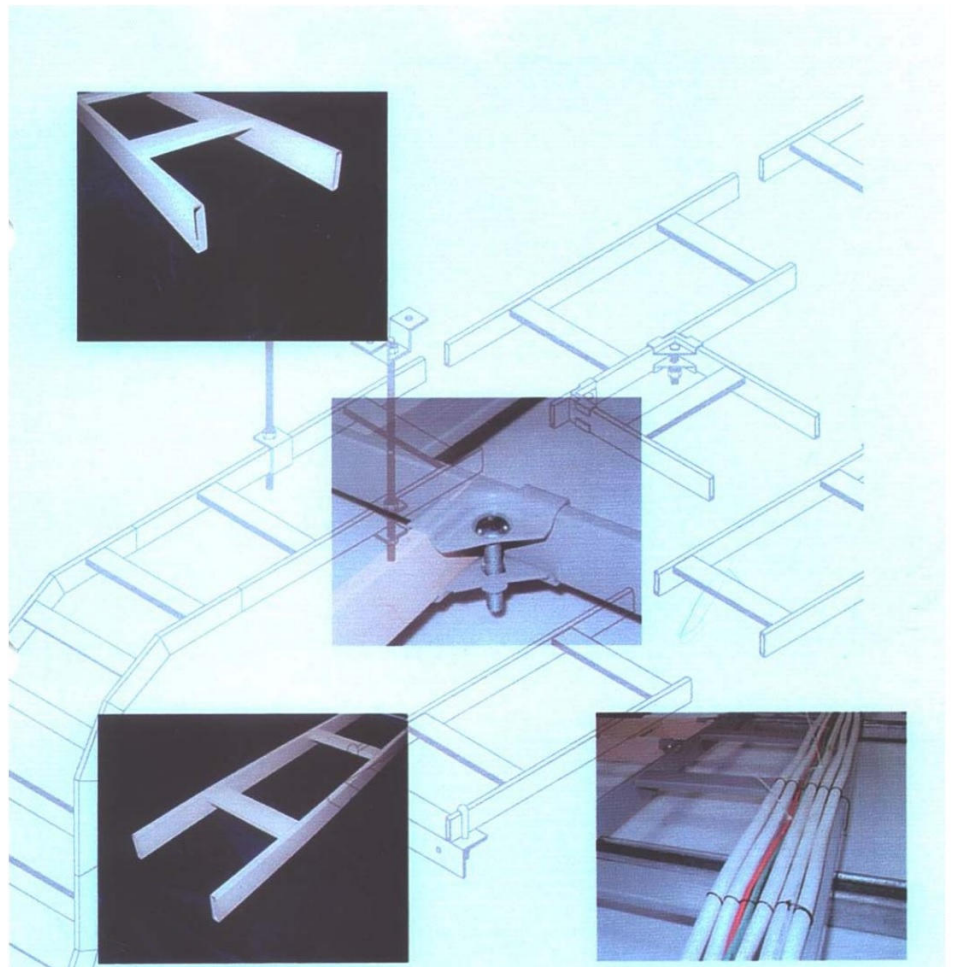

**Cable Runway System for Power, Control,  
Instrumentation Cable & Pneumatic Tubing**

## CONTENTS

### General & Technical Information

|                       |     |
|-----------------------|-----|
| Content.....          | 338 |
| Straight Length ..... | 339 |

### AB-Cope Cable Runway Fittings

|   |     |
|---|-----|
| Vertical Riser Inside and Out Side..... | 341 |
|---|-----|

### Connectors & Hardware

|   |     |
|---|-----|
| Butt Splice Kit and Junction Splice Kit ..... | 340 |
| Triangular Support and Wall Support Kit.....  | 342 |
| Channel Support Kit.....                      | 343 |
| Foot Kit.....                                 | 344 |
| End Kit, End Cap, and L Bracket.....          | 345 |

## Contents

**Straight Length**

**Butt-Splice Kit**

**Junction Splice**

**Radius Bend (Inside Riser, Outside Riser)**

**Triangular Welded Bracket**

**Wall Angle Support Kit**

**Channel Support Kit**

**Foot Kit**

**Heavy Duty Junction Splice Kit**

**Auxiliary Framing Bar Splice Kit**

**End Closing Kit**

**Protective End Caps**

**"L" Bracket**

## Straight Length

- Tubular steel Cable Runway is still setting standards when it comes to providing quality value. Tubular construction design weights half as much as equivalent solid bar types. Significantly reducing shipping and handling cost, and also minimizing expensive installation time. We strive to offer the widest selection of sizes and finishes available.
- Our Cable Runway is made of 10mm x 40mm x 1.5mm rectangular steel tubing with rung members welded at 12” intervals.
- Upon ordering : Available finish is gray or white powder coating. Special width size and finish are available on request.



### Ordering Information

| <i>Catalogue No.</i> | <i>Width (W)</i> | <i>Length (L)</i> | <i>Rung Spacing</i> | <i>Color Specs.</i> |
|----------------------|------------------|-------------------|---------------------|---------------------|
| CRLG-06SL-3M-12      | 6" (152mm)       | 3000mm            | 12: (305mm)         | Gray P.C.           |
| CRLG-12SL-3M-12      | 12" (305mm)      | 3000mm            | 12: (305mm)         | Gray P.C.           |
| CRLG-018L-3M-12      | 18" (457mm)      | 3000mm            | 12: (305mm)         | Gray P.C.           |
| CRLG-24SL-3M-12      | 24" (610mm)      | 3000mm            | 12: (305mm)         | Gray P.C.           |
| CRLG-30SL-3M-12      | 30" (762mm)      | 3000mm            | 12: (305mm)         | Gray P.C.           |

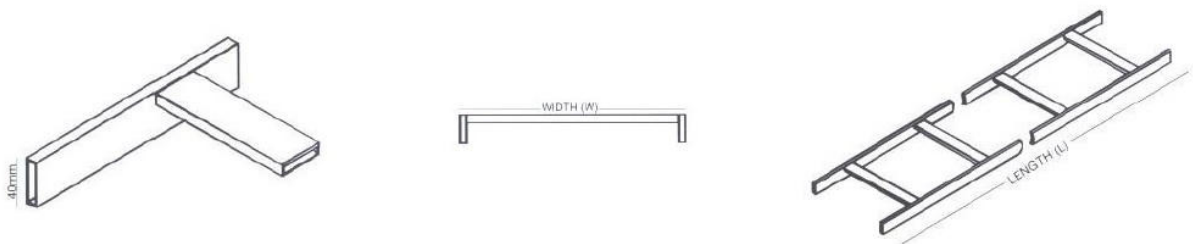

## Butt –Splice Kit

- Kit contains material to butt-splice 1 1/2 “ cable runway. The plates, bolts and nuts will fit existing solid steel as well as tubular cable runway.

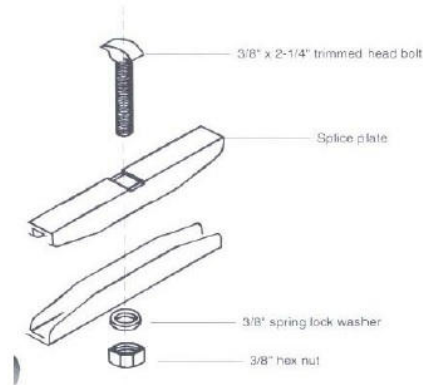

| <i>Catalogue No.</i> | <i>Parts Included</i>   |
|----------------------|---|
| CRL-BSK              | <ul style="list-style-type: none"> <li>• 4 each splice plates</li> <li>• 2 each 3/8" x 2" round head bolts</li> <li>• 2 each 3/8" hex nuts</li> <li>• 2 each 3/8" lock washers</li> </ul> |

## Junction Splice

- To complete a right angle cable runway T-Junction.

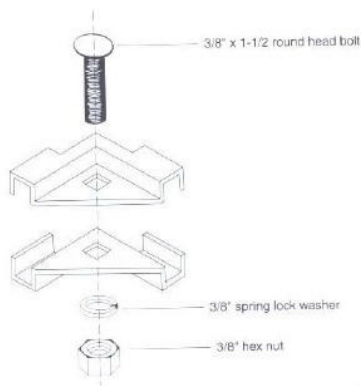

| <i>Catalogue No.</i> | <i>Parts Included</i>   |
|----------------------|---|
| CRL-JS               | <ul style="list-style-type: none"> <li>• 4 each corner clamp plates</li> <li>• 2 each 3/8" x 2" round head bolts</li> <li>• 2 each 3/8" hex nuts</li> <li>• 2 each 3/8" lock washers</li> </ul> |

## Cable Runway Radius Bend : Outside Riser

- Creates a smooth, gradual bend when cascading cable runs.

### Ordering Information

| <i>Catalogue No.</i> | <i>Runway Width</i> | <i>Radius (R)</i> |
|----------------------|---------------------|-------------------|
| CRLG-0690-R          | 06"                 | 292mm             |
| CRLG-1290-R          | 12"                 | 292mm             |
| CRLG-1890-R          | 18"                 | 292mm             |
| CRLG-2490-R          | 24"                 | 292mm             |
| CRLG-3090-R          | 30"                 | 292mm             |

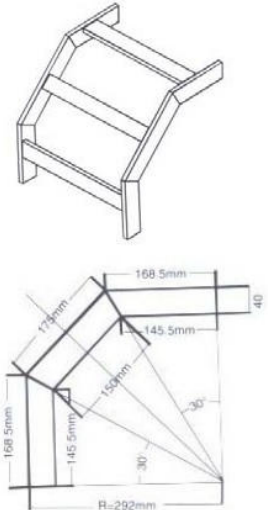
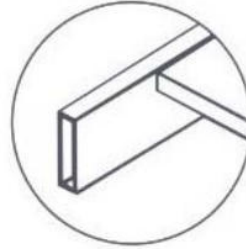

## Cable Runway Radius Bend: Inside Riser

- Creates a smooth, gradual bend when cascading cable runs.

### Ordering Information

| <i>Catalogue No.</i> | <i>Runway Width</i> | <i>Radius (R)</i> |
|----------------------|---------------------|-------------------|
| CRLG-0691-R          | 06"                 | 292mm             |
| CRLG-1291-R          | 12"                 | 292mm             |
| CRLG-1891-R          | 18"                 | 292mm             |
| CRLG-2491-R          | 24"                 | 292mm             |
| CRLG-3091-R          | 30"                 | 292mm             |

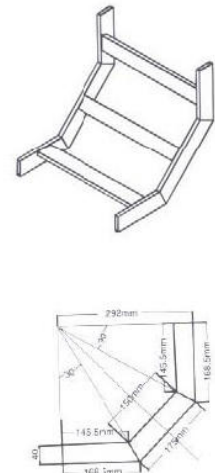
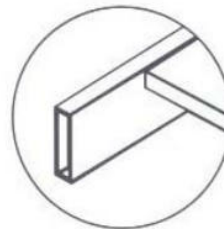

## Triangular Support Kit

- Triangular welded brackets provides wall support for cable runway.
- Material is 6mm x 50mm flat bar.
- Upon Ordering : Finish is available on request (gray or white coating)

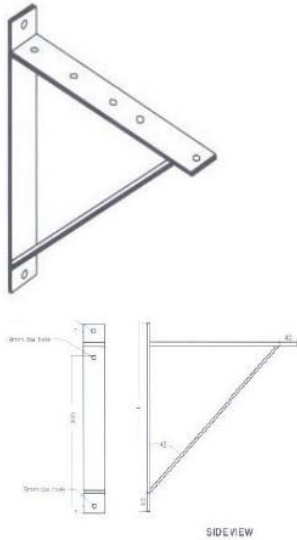
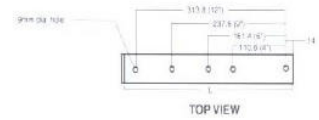

| <i>Catalogue No.</i> | <i>Cable Runway Width</i> | <i>Length (L)</i> | <i>Hole Distance</i> | <i>Color Specs.</i> |
|----------------------|---------------------------|-------------------|----------------------|---------------------|
| CRL-200TSB-G         | 4" – 6"                   | 200mm             | W+9 mm               | Gray P.C.           |
| CRL-350TSB-G         | 6" – 12"                  | 350mm             | W+9 mm               | Gray P.C.           |
| CRL-502TSB-G         | 18"                       | 502mm             | 466mm                | Gray P.C.           |
| CRL-655TSB-G         | 24"                       | 655mm             | 619mm                | Gray P.C.           |
| CRL-805TSB-G         | 30"                       | 807mm             | 771mm                | Gray P.C.           |

Kits consists of

- 1 each triangular bracket
- 2 each 5/16" x 2 1/2 " J-bolt EG
- 2 each 5/16" hex nuts, EG
- 2 each 5/16" lock washers, EG

## Wall Angle support kit

- 2" x 2" x 3/16" thick, Steel support angle is cut and drilled for wall mounting specific widths for cable runway.

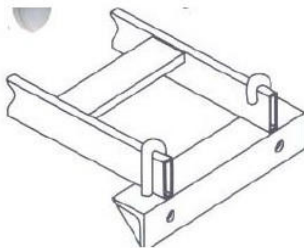

| <i>Catalogue No.</i> | <i>Cable Runway Width</i> | <i>Dimension "A"</i> | <i>Dimension "B"</i> | <i>Dimension "C"</i> |
|----------------------|---------------------------|----------------------|----------------------|----------------------|
| CRLG-06WASH          | 06"                       | 201mm                | 161.4mm              | 99mm                 |
| CRLG-12WASH          | 12"                       | 354mm                | 314mm                | 252mm                |
| CRLG-18WASH          | 18"                       | 506mm                | 466mm                | 404mm                |
| CRLG-24WASH          | 24"                       | 658m                 | 618.6mm              | 556mm                |
| CRLG-30WASH          | 30"                       | 811mm                | 771mm                | 709mm                |

Kits consists of

- 1 each wall angle (size ordered)
- 2 each 5/16" x 2 1/2 " J-bolt
- 2 each 5/16" hex nuts
- 2 each 5/16" lock washers

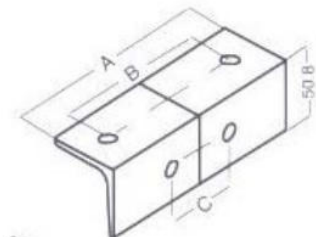
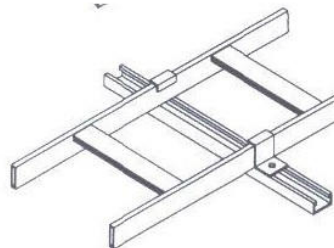

## Channel Support Kit

| <i>Catalogue No.</i> | <i>Cable Runway Width</i> | <i>Channel Width</i> |
|----------------------|---------------------------|----------------------|
| CRLG-06CSK           | 06"                       | 10"                  |
| CRLG-12CSK           | 12"                       | 16"                  |
| CRLG-18CSK           | 18"                       | 22"                  |
| CRLG-24CSK           | 24"                       | 28"                  |
| CRLG-30CSK           | 30"                       | 34"                  |

Kits consists of

- 1 each channel (41mm x 21 mm)
- 2 each 3/8" short spring nut
- 2 each 3/8" x 3/4" hex head bolt
- 2 each 3/8" lock washers
- 2 each hold down clamp

## Foot kit

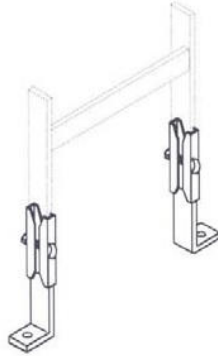

| <i>Catalogue No.</i> | <i>Parts Included</i>  |
|----------------------|--|
| CRLG-FK              | <ul style="list-style-type: none"> <li>• 2 each cable rack feet</li> <li>• 4 each splice plates</li> <li>• 2 each 3/8-16 x 2 1/4" trimmed head bolts</li> <li>• 2 each 3/8-16 hex nuts</li> <li>• 2 each 3/8" lock washers.</li> </ul> |

- Foot made of 3/8" x 1 1/2" x 6" (H) steel.
- To attach and secure cable runway to a wall or floor.

## Heavy Duty Junction Splice Kit

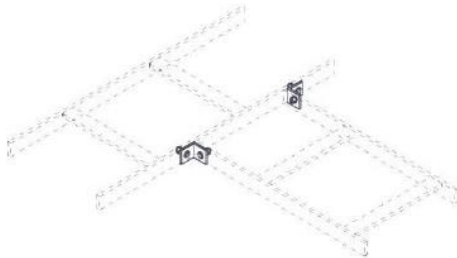

| <i>Catalogue No.</i> | <i>Parts Included</i>  |
|----------------------|--|
| CRLG-HD-JS           | <ul style="list-style-type: none"> <li>• 2 each Splice angles</li> <li>• 2 each 3/8-16 hex nuts</li> <li>• 2 each 3/8 split lock washers</li> <li>• 4 each 3/8-16 x 1 1/4" hex cap screws</li> </ul> |

- Cable runway drilling is required.
- Bolt-through junction splice kit for vertical runs or to meet seismic requirements.
- Materials is 50 x 50 x 5 mm steel angles.

## Auxiliary Framing Bar Splice Kit.

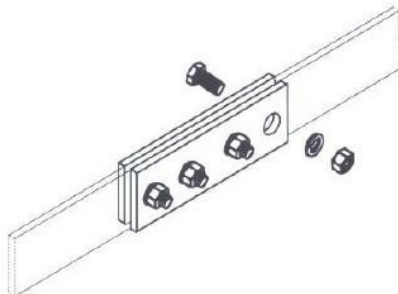

| <i>Catalogue No.</i> | <i>Parts Included</i>   |
|----------------------|---|
| CRLG-AFBS            | <ul style="list-style-type: none"> <li>• 2 each Splice bars</li> <li>• 4 each 1/2 - 13 hex cap screws.</li> <li>• 4 each 1/2 -13 hex nuts and split lock</li> </ul> |

- Butt - Splices 3/8" x 2" Auxiliary Framing Bar.
- Drilling the framing bar 6 x 50 x 152 mm long.

## End Closing Kit

To close an un-spliced end of cable runway. Made of 10mm x 40mm x 1.5 mm thick rectangular steel tubing.

Kit consists of

- 1 each end closing bar.
- 4 each corner clamp plates
- 2 each 3/8" x 2" round bead bolts.
- 2 each 3/8" hex nuts

Part No.

CRLG-(W)ECK

W= width (6", 12", 18", 24" and 30")

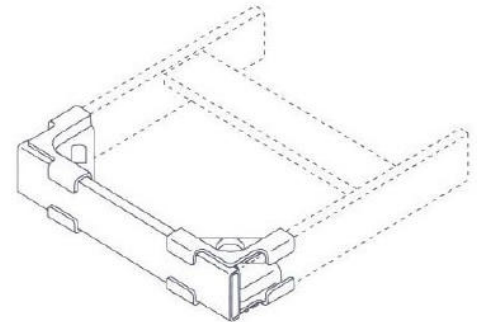

## Protective End Caps

Covers and protects exposed ends of cable runway and Auxiliary Framing Bar and Channel. Reduces chances of personally inquiry and equipment damage.

- Made of colored rubberized material.
- Sold in Pairs.

| <i>Part Number</i> | <i>Description</i>  |
|--------------------|---------------------|
| CRLG-PEC           | Protective End Caps |

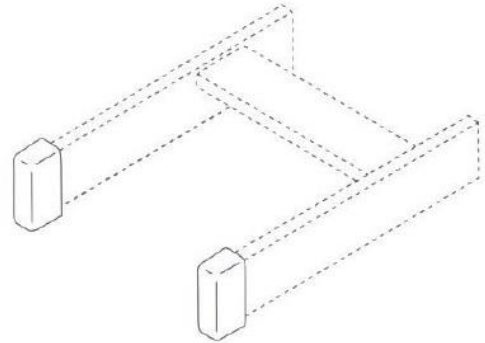

## "L" Bracket

Brackets provides a separate facility for running power conductors or other cables that should be physically separated from main cables.

Kit consists of 1 each

- bracket for 10mm x 40mm stringer
- 1/4" x 3/4" hex bolt with nut and washer

| <i>Part Number</i> | <i>Description</i> |
|--------------------|--------------------|
| CRLG-LB            | "L" Bracket        |

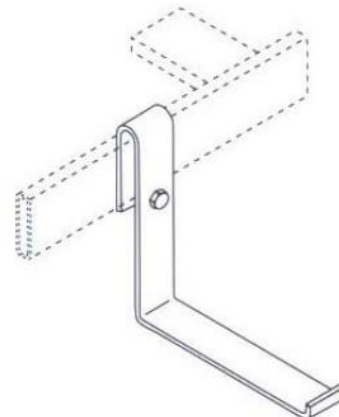



# AB-COPE CABLE BUS

# 14

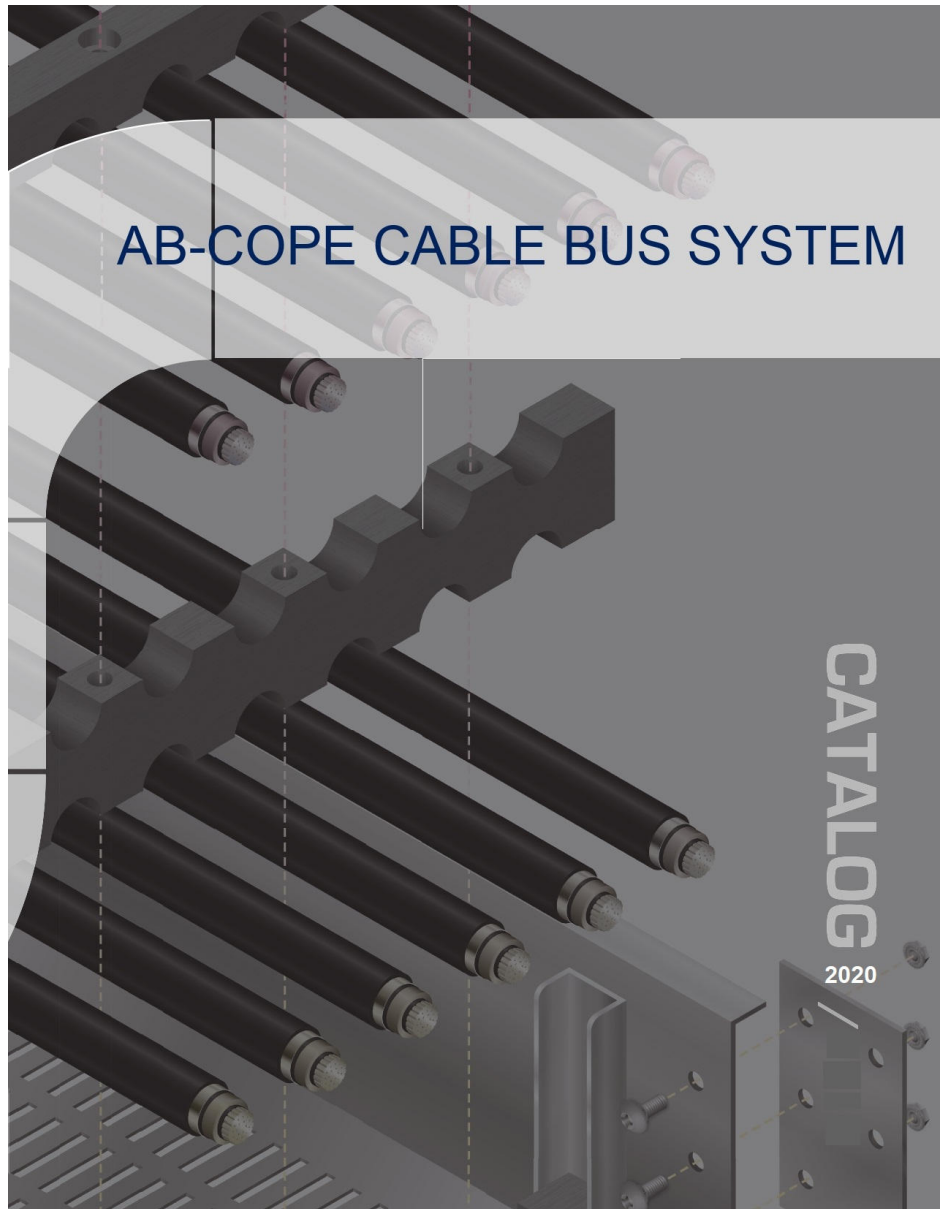

Cable BUS System for Power, Transmission

## CONTENTS

### General & Technical Information

|                                      |         |
|--------------------------------------|---------|
| Introduction.....                    | 350     |
| Advantages .....                     | 351     |
| Application .....                    | 352     |
| Design .....                         | 352-355 |
| Accessories .....                    | 356-360 |
| Testing and Qualification .....      | 361     |
| Selection Guide and Grounding, ..... | 362     |
| Comparison .....                     | 363     |
| Cross-section View .....             | 364-367 |

### AB-Cope Cable Bus Fittings

|             |         |
|-------------|---------|
| Elbows..... | 368-370 |
|-------------|---------|

### Specification Information

|                                   |         |
|-----------------------------------|---------|
| Qualifications and Standards..... | 371-372 |
|-----------------------------------|---------|

## AB-COPE CABLE BUS SYSTEM

RELIABLE, ALL-WEATHER, MAINTENANCE-FREE POWER DISTRIBUTION SYSTEMS  
MANUFACTURED IN SAUDI ARABIA

### ABOUT US

AB-COPE Cable Bus, Inc was founded in 2013 by an experienced, technically-savvy and team-oriented group of electrical engineers with over 50 years of combined experience in the power distribution industry. We design and manufacture safe, reliable, maintenance-free Cable Bus systems for a variety of applications. We are dedicated to promoting the best interests of our clients and their businesses by providing customized solutions that maximize efficiency and minimize cost. Expert technical support and personalized customer service guide each project to completion, ensuring satisfactory results. We look forward to working with you.



### CONTACT US

**PHONE** ..... +966 13 8086569

**SALES**.....+966 59 6455741

**EMAIL** ..... [abcope@abahsain.net](mailto:abcope@abahsain.net)

**ADDRESS** ..... 2nd Industrial city  
Dammam,  
Saudi Arabia



# contents

## CABLE BUS OVERVIEW & ADVANTAGES

Cable Bus is a reliable, versatile, all-weather electric power feeder system comprised of insulated power cables inside a ventilated, protective metal enclosure. Compact, sturdy, and easy to install, no spare parts or maintenance are required. System ratings range from 480V to 69kV and 800 to 6000 Amps.

## APPLICATIONS & INDUSTRIES SERVED

Cable Bus is used to connect a variety of electrical apparatuses: main power feeders, power generators and transformers, switchgear, motion and control equipment, UPS systems and more. Industries currently using Cable Bus systems include oil & gas, utilities, pulp & paper, mining and petrochemical processing. For past project profiles, see page 25.

## SYSTEM DESIGN & CONSTRUCTION

Our ventilated, structural-grade aluminum enclosures include short-circuit braces and cable support blocks to ensure safety in cases of fault or fire.

## ACCESSORIES & CUSTOMIZATION

Each system is customized to suit your project's unique spatial, environmental, and equipment requirements. We design custom termination boxes, tap boxes, top hats, firestops, wall and floor penetrations (with or without environmental seals), flexible joints, and more.

## ENGINEERING CALCULATIONS & TESTS

All standard heat rise, ampacity and inductive reactance calculations are available. We also provide impedance, and capacitance calculations upon request.

## CABLE BUS VS. ALTERNATIVES

For over five decades Cable Bus has demonstrated its superior reliability. Easy to install compared to other systems, no heavy lifting equipment or special tools are required. Unlike traditional, non-segregated phase bus duct systems, there are no splices or connections to re-torque, and no space heaters or thermostats to install or replace.

## SYSTEM CROSS-SECTIONS & DIMENSIONS

Cable Bus systems are designed per system ratings. Enclosures and accessories can be designed to fit unique spatial requirements.

## ELBOW/OFFSET DIAGRAMS & DIMENSIONS

All elbows are curved to follow the power cables' bending radius perfectly. Standard horizontal and vertical elbows come in 15°, 30°, 45°, 60° and 90° bends. Custom elbows are also available to meet your specific job requirements.

## STANDARD SYSTEM SPECIFICATIONS

Ventilation openings for top and bottom enclosure covers are 1/4" by 2" and comprise 50% of the covers' total area. This allows the system to operate at a free air rating. Bottom covers are factory welded to the enclosure side rails and short-circuit braces. Top covers are fastened to the housing with self-drilling screws and are easily removable for system inspection.

## QUALIFICATIONS, STANDARDS & PROTOCOLS

Cable Bus is defined by the National Electric Code Article 370 for use in the US. The design and testing of Abcope Cable Bus systems are based on IEEE C37.23

## QUALITY CONTROL & QUALITY ASSURANCE

Abcope Cable Bus, Inc. employs an in-house Quality Assurance program based on ISO-9001 guidelines. All Cable Bus enclosures and components are vigorously scrutinized before shipment to ensure the highest quality is maintained. All inspection data and ITP are available upon request.

## PROJECT PROFILES & CLIENTS

Abcope Cable Bus systems function beautifully in conditions ranging from heavy pollution to extremes of temperature to high humidity to intense UV light. Systems are installed in a range of industrial, commercial, and civil settings.

## QUOTE REQUEST FORM

Fill-out this form or visit us online at [advcablebus.com](http://advcablebus.com) to request a customized Cable Bus proposal.

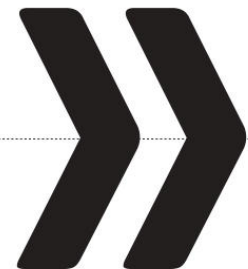

## WHAT IS CABLE BUS?



“An assembly of insulated conductors with fittings and conductor terminations in a completely enclosed, ventilated protective metal housing. Cablebus is ordinarily assembled at the point of installation from the components furnished or specified by the manufacturer in accordance with instructions for the specific job. The assembly is designed to carry fault current and to withstand the magnetic forces of such current.”

– NATIONAL ELECTRIC CODE (NEC 2011)  
Section 370. Cablebus

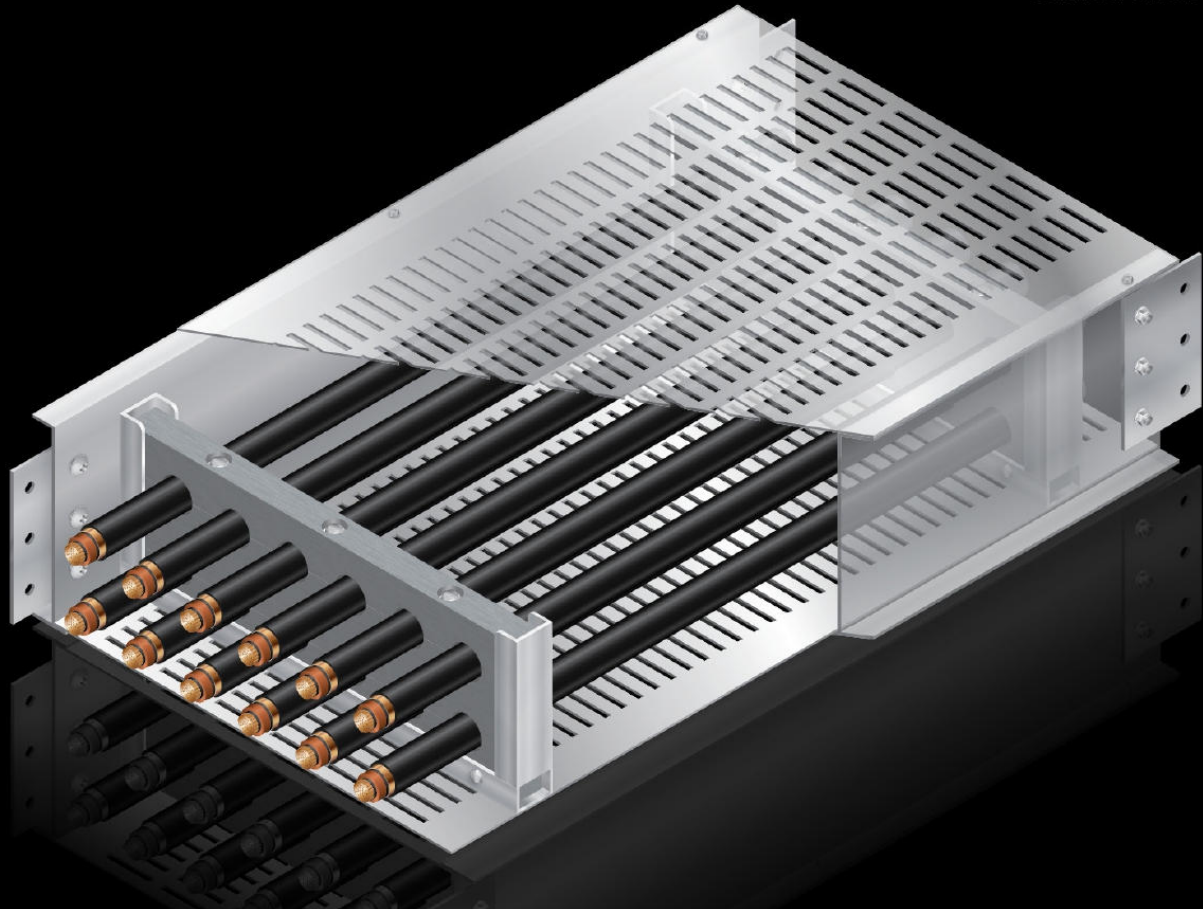

**CABLE BUS** is a system for distributing power from one electrical apparatus to another using insulated power cables inside of a protective metal housing. Cable Bus is designed to carry large amounts of electrical power for use within power generation and industrial plants for service entrances, main feeders, distribution applications, and retrofits for existing power systems. Each AB-COPE Cable Bus system is custom designed and manufactured to meet your specific job requirements. Uniform conductor spacing is maintained by our custom-manufactured cable support blocks, which are themselves held in place by the U-form short-circuit braces welded into each enclosure section. The combination of the cable support blocks and the short-circuit braces allows our systems to withstand short-circuit forces of up to 100kA RMS symmetrical, keeping personnel and equipment safe if a fault occurs.

AB-COPE Cable Bus manufactures enclosure covers that are 50% ventilated. The ventilation and conductor spacing allow our systems to operate at free air rating. Each cable can conduct more power without a corresponding rise in temperature. Accordingly, Cable Bus systems employ fewer cables than cables in tray or cables in conduit, which impacts project costs significantly.

AB-COPE Cable Bus systems have an ampacity range from 800A to 6000A, and voltage ratings of 480V, 600V, 5kV, 15kV, 25kV, 35kV, and occasionally up to 69kV. Typical applications include connections between transformers and switchgear, tie connections between two pieces of switchgear, between motor control centers and large motors, or between generators and generator breakers or generator step-up transformers. We commonly work on industrial facilities and other types of applications where a large amount of current is needed.



# THE CABLE BUS ADVANTAGE

## ■ RELIABLE, FAIL-SAFE POWER

For over five decades, Cable Bus has demonstrated its superior reliability in the power generation, mining, petrochemical and paper industries, as well as countless others. Cable Bus systems function beautifully in conditions ranging from heavy pollution to extremes of temperature, humidity and UV light. From humid tropics to arid deserts and frozen tundras, AB-COPE Cable Bus systems are custom engineered to operate reliably in any climate, anywhere in the world.

## ■ COST-EFFECTIVE & ENERGY EFFICIENT

With material and installation costs up to 40% less than conventional, non-segregated phase bar bus, cable tray with armored cables, or conduit and wire systems, Cable Bus is often the most cost-effective way of distributing electricity.

## ■ FLEXIBLE & VERSATILE

We take pride in providing the most accurately designed and manufactured systems on the market. However, during the course of a project, unexpected circumstances can occur. In order to keep the project on track and avoid delays, all our systems are furnished with an extra housing section that can be cut to fit if the need arises. The power cables we supply also include a complimentary 5% in additional length to accommodate any discrepancies encountered in the field.

## ■ EASY TO INSTALL

AB-COPE Cable Bus systems are easy to install compared to other systems. No heavy lifting equipment or special tools are required. Two men can easily lift housing sections into place. Every job is engineered and designed to fit the specific application with all Cable Bus sections, elbows and accessories factory pre-cut to fit your project needs. Long vertical sections are easily installed using our short-circuit braces, which allow the cable support blocks to be installed without any fasteners until all the power cables have been pulled into place. Interleaving or crossing of conductors within the Cable Bus enclosure is not required with our systems.

## ■ MAINTENANCE-FREE

AB-COPE Cable Bus systems are completely maintenance-free. Unlike traditional, non-segregated phase bus duct systems, there are no splices, no connections to re-torque, and no space heaters or thermostats to install or replace. ■

*Custom Engineered for Maximum Performance*

RELIABLE, ALL-WEATHER, MAINTENANCE-FREE POWER DISTRIBUTION SYSTEMS

CUSTOM DESIGNED & MANUFACTURED IN THE KINGDOM OF SAUDI ARABIA

# TYPICAL APPLICATIONS



## MAIN INCOMING & DISTRIBUTION FEEDERS

These include main feeders to facilities, whether they are medium or low voltage systems. These include feeders at industrial plants, mining and metal facilities, oil & gas and oil sands facilities, data center facilities, and UPS feeds.



## POWER GENERATION PLANTS

Cable Bus can be used as main generation feeds, station service feeds, auxiliary feeds, and excitation feeds.



## POWER DISTRIBUTION SUBSTATIONS

For many utilities, Cable Bus is the preferred choice for feeders connecting the power transformers' LV terminals to the switchgear lineups before the power gets distributed to the distribution circuits.



## RENEWABLE ENERGY SOLUTIONS

Solar Plant collector substation links between collector transformers and switchgears.

# SOLUTIONS BY INDUSTRY

## OIL, OIL SANDS & GAS

Historically, Cable Bus has been used at extraction plants, refineries, processing plants, and distribution plants everywhere from the Middle East to Texas; South America to the Arctic.



## MINING & METALS

Because of its flexibility and reliability, Cable Bus is a great fit for projects where there may be uncertainty in job site final dimensions. The low losses and balanced line parameters result in better voltage drops and power quality.



## ELECTRICAL UTILITIES

Applications for electric utilities include generator main power feeds, station service feeds, FGD feeds, auxiliary feeds, and excitation system feeds.



## INDUSTRIAL LOADS

Cable Bus provides economical options for a wide range of voltage and current ratings, especially for main distribution or industrial load feeders.



## PUBLIC BUILDINGS

Cable Bus's flexibility allows for feeder designs to fit into a wide range of building design aesthetics and follow odd routes at smaller cross-sections than other types of feeders.

## Typical CABLE BUS Assembly

- STURDY, ALL-WEATHER, EASY TO INSTALL & MAINTENANCE-FREE
- ACCESSORIES INCLUDE JUNCTION BOXES, FIRESTOPS & FLASH PROTECTION, WALL, FLOOR AND EQUIPMENT SEALS AND MORE

○ VENTILATED ENCLOSURE COVERS

○ CABLE SUPPORT BLOCKS

○ INSULATED POWER CABLES

○ SPLICE PLATES

○ SHORT-CIRCUIT BRACES

○ NO.-1 FORM SIDE RAILS ○

## » SYSTEM DESIGN & CONSTRUCTION

### 6063-T6 ALUMINUM ENCLOSURES

Each AB-COPE Cable Bus system begins with a compact enclosure design. Once the initial goal of maintaining equal and constant spacing of the system's conductors is reached, the height and width of the enclosure can be customized to suit our clients' spatial requirements. Spacing the conductors appropriately allows the power cables in our systems to operate with a free air rating at maximum ampacity. This reduces the total number of conductors per system, which in turn allows us to minimize the dimensions of the enclosure that houses them.

Every AB-COPE Cable Bus system is custom designed and manufactured per client specifications. Our standard, all-welded enclosures are made of structural grade 6063-T6 aluminum alloy, which is extremely sturdy and weather-resistant. All our welds are made inside the enclosure, lending a cleaner, more aesthetically pleasing look to the entire system.

Anodized aluminum and steel (hot-dip galvanized after fabrication) enclosures are also available. Please contact our office for more information.

Top and bottom covers of the Cable Bus enclosure are 50% ventilated to maximize the free air rating of the power cables inside.

### VENTILATED ENCLOSURE COVERS

The top and bottom covers of our enclosures are flat, slotted aluminum sheets with 1/2" by 2" openings and 50% open area for maximum ventilation. The bottom covers are factory welded in place to the enclosure side rails, while the top covers are fastened to the housing with self-drilling screws and are easily removable for system inspection. Our short-circuit braces are factory welded to the side rails as well for additional mechanical strength and a more compact housing.

### INSULATED POWER CABLES

Single conductor, insulated power cables form the core of every AB-COPE Cable Bus system. Our systems are designed to employ cable types that are approved for both indoor and outdoor use, ensuring a safe, reliable power supply, regardless of environmental conditions.

Great care is taken to select the proper cables for your project, and AB-COPE Cable Bus only furnishes cable from manufacturers with outstanding reputations for quality and service. Conductors are selected in reference to each client's specified system voltage class, insulation and jacketing materials, and desired flame test rating. The number of cables used in each system is determined based on the amperage, voltage drop and maximum operating temperature requirements.



Power cables are shipped on large, wooden reels for easy transport, handling and installation.



### NO.1-FORM ENCLOSURE SIDE RAILS

AB-COPE Cable Bus system enclosures are manufactured using extruded, structural grade 6063-T6 aluminum side rails. Our uniquely-shaped side rails create a stronger enclosure, which allows for longer spans (up to 20 feet). These longer spans can drastically reduce the amount of support material required for your project.

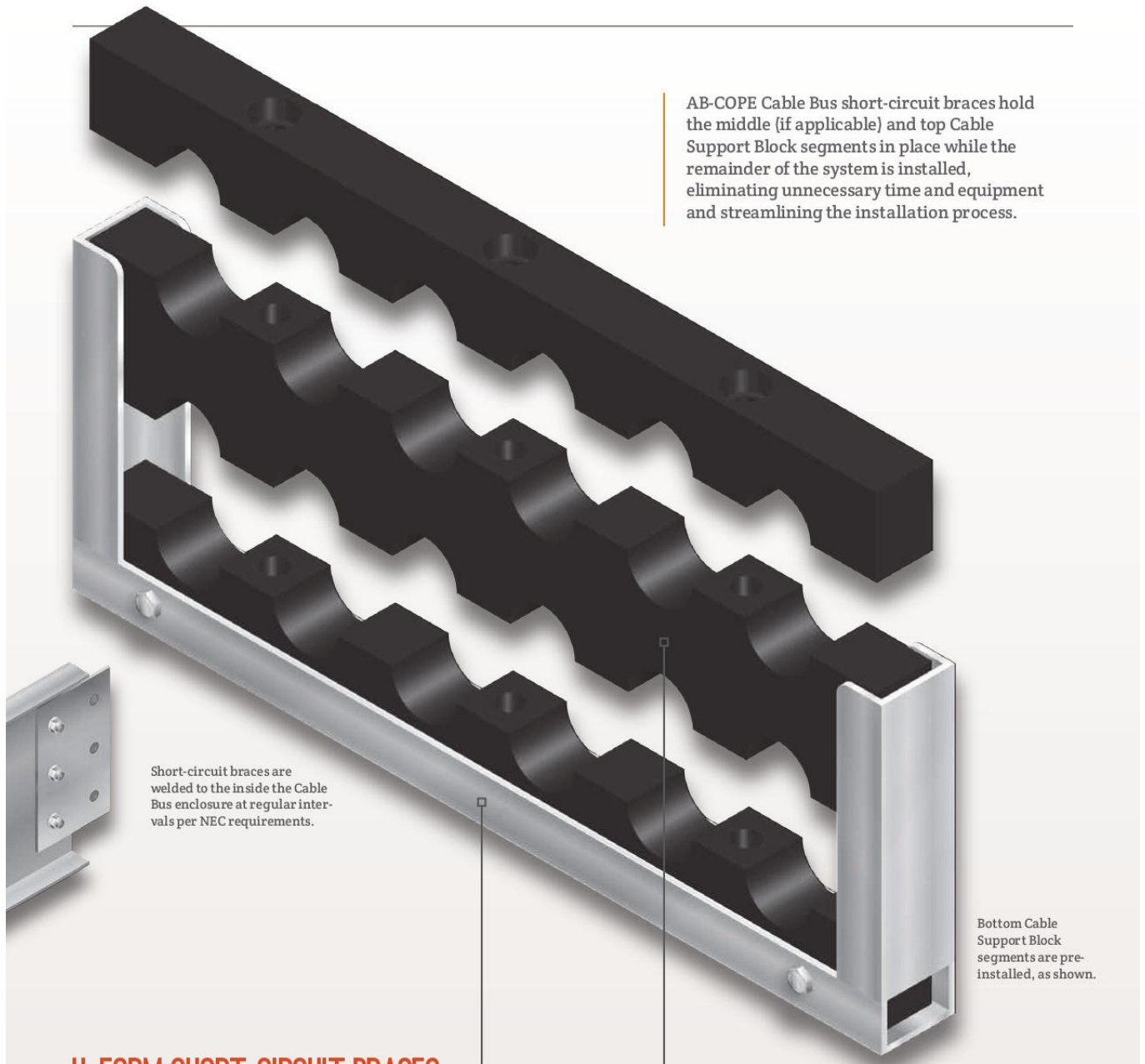

AB-COPE Cable Bus short-circuit braces hold the middle (if applicable) and top Cable Support Block segments in place while the remainder of the system is installed, eliminating unnecessary time and equipment and streamlining the installation process.

Short-circuit braces are welded to the inside the Cable Bus enclosure at regular intervals per NEC requirements.

Bottom Cable Support Block segments are pre-installed, as shown.

## U-FORM SHORT-CIRCUIT BRACES

Our industry exclusive, U-shaped short-circuit braces lend additional strength and rigidity to the Cable Bus enclosure. Constructed from 6063-T6 aluminum and factory welded to the enclosure side rails, the short-circuit braces serve a dual purpose. Though their primary functions are support and protection, they serve to streamline the Cable Bus installation process as well.

Short-circuit braces hold the cable support blocks in place, helping to maintain conductor spacing. Together with the cable support blocks, they allow our systems to withstand short-circuit mechanical forces of up to 100kA RMS.

Short-circuit braces are also helpful during installation: they allow the power cables and cable support blocks to be installed without the hassle of temporarily installing block clamping bolts until after all of the cables are in place. This is true for both horizontal and vertical bus runs.

## CABLE SUPPORT BLOCKS

Each system's power cables are firmly supported within the Cable Bus enclosure by our cable support blocks. Our standard cable support blocks are made from treated hard-rock maple wood, which is primed and coated with fire retardant paint. High-density polyethylene (HDPE) cable support blocks are also available.

Our cable support blocks are high-strength, non-conductive, non-tracking, non-hygroscopic, and will not degrade at high temperatures or in the presence of pollution or ultraviolet light. Our systems are designed to withstand a wide range of environmental conditions and are extremely reliable, boasting an average service life of over 40 years.

## ACCESSORIES & CUSTOMIZATION

**Every project is unique.** We provide the necessary equipment to ensure your project is accomplished in a cost-effective, timely manner, and your Cable Bus system runs reliably as soon as it's powered-up. In addition to all of the accessories listed below, we can provide flash barriers (for Arc Resistant Switchgear), flexible joints (when vibration is an issue) and copper bus bars. We are here to provide the

engineering, expertise and equipment to see that your project is a success. Our default enclosure material is high-strength, 6063-T6, structural grade aluminum alloy. The No. 1 Form Side Rails are extruded, and the Top and Bottom Covers are flat, ventilated sheets. Aluminum enclosures can be powder-coated or anodized. Stainless steel, and hot-dipped, galvanized (after fabrication) steel are also available.

## STANDARD ACCESSORIES



### Termination Boxes

We can design and build junction boxes to meet your unique system requirements. Tap Boxes, transformer Termination Boxes and switchgear/MCC top hats can all be customized to provide the necessary space to complete the installation. The boxes are constructed from aluminum angle frames—seam welded for outdoor applications, stitch welded for indoor applications—and have removable panels for easy access.

AB-COPE Cable Bus Termination Boxes ensure sufficient space is available to terminate conductors to electrical equipment. Outdoor boxes use gasketed, removable panels, fully seam welded fixed panels, and an HDPE equipment seal block to ensure a watertight enclosure.

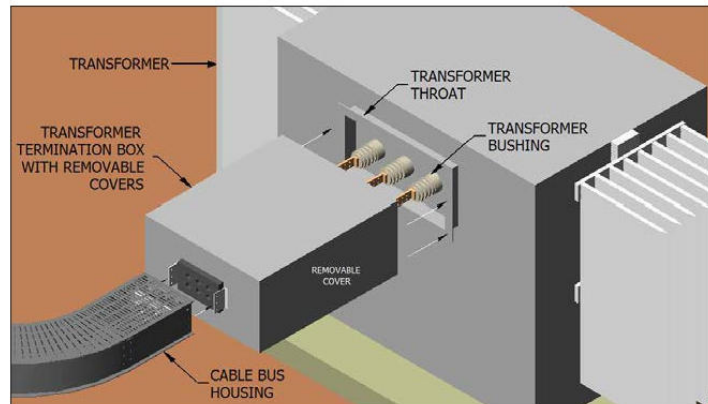

### MCT Firestops

We use MCT (Multi Transit) type Fire Stops to provide a 2-hour rated, UL listed fire barrier. MCT seals are used when an absolutely watertight fitting is required. All installation hardware included.



IMMEDIATE RIGHT—Installed AB-COPE Cable Bus system featuring a firestop/wall seal.

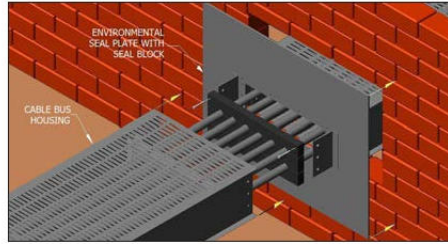

## Environmental Seals

Our Environmental Seals form a watertight seal with walls when a fire barrier is not required. They can also be used for floor penetrations that must be watertight. We have the standard square opening type seals with seal blocks, as well as cable gland type seals available. For the square opening type, conductors are sealed with Silicone sealant. Entrance fittings are furnished with all necessary hardware. Neoprene or high-density polyethylene (HDPE) blocks are inserted after the cables are installed for ease of pulling. Environmental seals with cable glands will consist of the seal plates with openings made for each cable, and cable glands provided for each cable's passage through the seal. Selection of seal type will depend on application type and the Cable Bus configuration, as different types of seals will have different drawbacks and strengths.



IMMEDIATE LEFT—Installed AB-COPE Cable Bus system featuring two sequential **wall penetrations/seals** with **firestops**.  
LOWER LEFT—Installed Advanced Cable Bus system (in a trench) featuring a **wall penetration/seal**.



## Connection/Bus End Flanges

Connection Flanges are used to connect the Cable Bus housing to the indoor electrical equipment (switchgear, motor control center, etc.) These flanges are open flanges and do not provide any environmental protection.

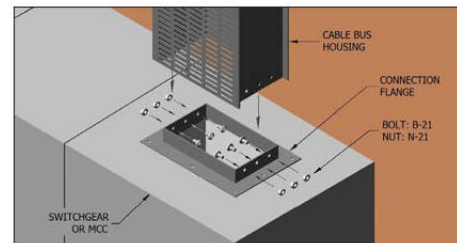

# CABLE ACCESSORIES



## Termination Lugs

NEMA standard Two- and Four-Hole Long Barrel compression lugs are used to terminate the power cables to the bus bars inside of electrical equipment. Each termination comes complete with Silicon Bronze termination hardware to attach the lugs to the termination points and ensure a reliable connection.

## Termination Kits

Termination Kits are available in both heat shrink and cold shrink types and can be used either indoors or outdoors. Termination Kits are provided for projects that use medium voltage cables rated 5kV and over. The type of termination kits can be specified by the client or stated in the project technical specifications.

RELIABLE, ALL-WEATHER, MAINTENANCE-FREE POWER DISTRIBUTION SYSTEMS

CUSTOM DESIGNED & MANUFACTURED IN THE KINGDOM OF SAUDI ARABIA

## SPECIAL ACCESSORIES

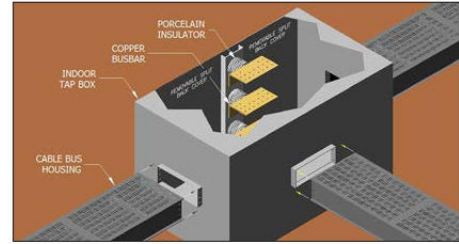

### Tap Boxes

Tap Boxes allow for intermediate load tapping. The design provides system voltage rated air separation between live parts and adjacent surfaces to eliminate the necessity of tapping all energized components. Typical Tap Boxes consist of an aluminum-framed enclosure, removable covers (gasketed for outdoor applications), porcelain or epoxy post stand-off insulators, and bus bars.



RIGHT—Installed Cable Bus system featuring a custom *tap box*.

### Flexible Connectors

Flexible connectors are provided for Cable Bus enclosure bends or connections where there are small and uncertain angles, or if there are expected vibrations at the connection point. The flexible connectors are manufactured as two connection flanges placed back-to-back with a rubber bellows between them that will act as the flexible element.

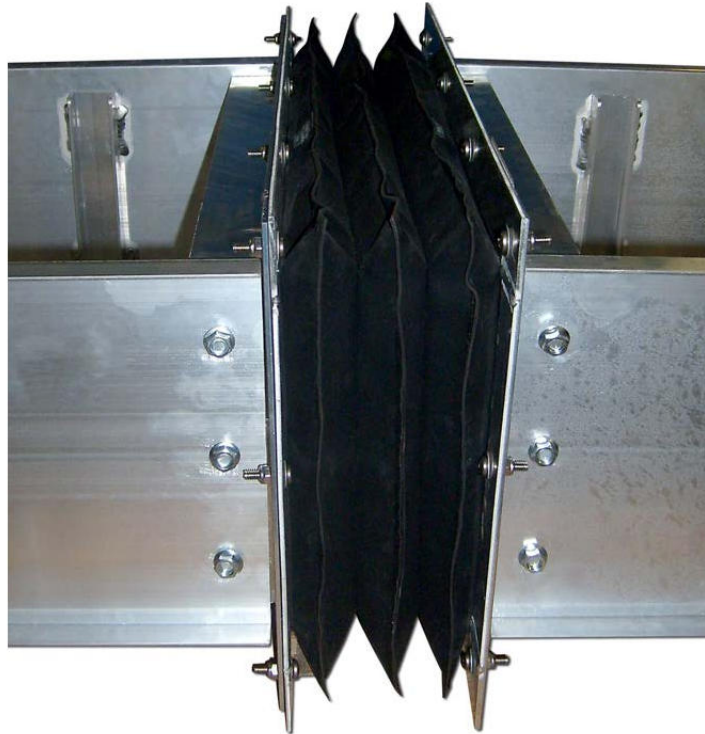

ABOVE—Factory standard *flexible connector* for seismically active job sites or vibration concerns.  
LEFT—Interior of a typical *tap box* showing conductors and terminations.

### Adapter Bus Bars

Adapter bus bars are items that may be required when the available terminal points of an equipment do not fit with the cable terminals. This situation sometimes occur when the project involves retrofitting older equipment or connecting Cable Bus to an equipment that was previously connected to rigid bus ducts. Adapter bus bars are designed and fabricated in order to accommodate the equipment's terminal hole pattern on one side, and the hole pattern of the cable termination lugs on the other end.

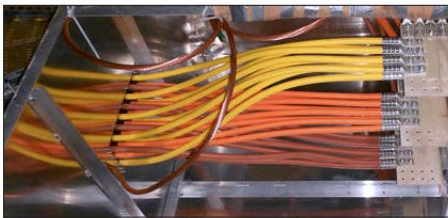

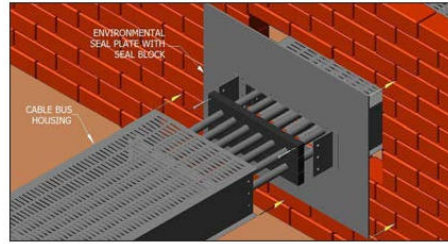

## Environmental Seals

Our Environmental Seals form a watertight seal with walls when a fire barrier is not required. They can also be used for floor penetrations that must be watertight. We have the standard square opening type seals with seal blocks, as well as cable gland type seals available. For the square opening type, conductors are sealed with Silicone sealant. Entrance fittings are furnished with all necessary hardware. Neoprene or high-density polyethylene (HDPE) blocks are inserted after the cables are installed for ease of pulling. Environmental seals with cable glands will consist of the seal plates with openings made for each cable, and cable glands provided for each cable's passage through the seal. Selection of seal type will depend on application type and the Cable Bus configuration, as different types of seals will have different drawbacks and strengths.



IMMEDIATE LEFT—Installed AB-COPE Cable Bus system featuring two sequential *wall penetrations/seals* with *firestops*.

LOWER LEFT—Installed Advanced Cable Bus system (in a trench) featuring a *wall penetration/seal*.



## Connection/Bus End Flanges

Connection Flanges are used to connect the Cable Bus housing to the indoor electrical equipment (switchgear, motor control center, etc.) These flanges are open flanges and do not provide any environmental protection.

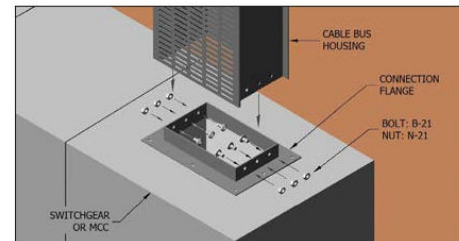

# CABLE ACCESSORIES



## Termination Lugs

NEMA standard Two- and Four-Hole Long Barrel compression lugs are used to terminate the power cables to the bus bars inside of electrical equipment. Each termination comes complete with Silicon Bronze termination hardware to attach the lugs to the termination points and ensure a reliable connection.

## Termination Kits

Termination Kits are available in both heat shrink and cold shrink types and can be used either indoors or outdoors. Termination Kits are provided for projects that use medium voltage cables rated 5kV and over. The type of termination kits can be specified by the client or stated in the project technical specifications.

RELIABLE, ALL-WEATHER, MAINTENANCE-FREE POWER DISTRIBUTION SYSTEMS

CUSTOM DESIGNED & MANUFACTURED IN THE KINGDOM OF SAUDI ARABIA

## SPECIAL ACCESSORIES

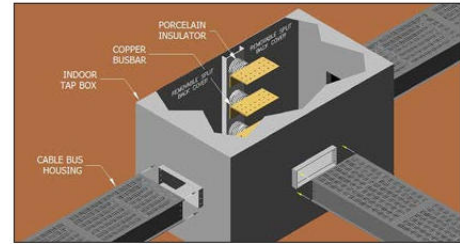

### Tap Boxes

Tap Boxes allow for intermediate load tapping. The design provides system voltage rated air separation between live parts and adjacent surfaces to eliminate the necessity of tapping all energized components. Typical Tap Boxes consist of an aluminum-framed enclosure, removable covers (gasketed for outdoor applications), porcelain or epoxy post stand-off insulators, and bus bars.



RIGHT—Installed Cable Bus system featuring a custom *tap box*.

### Flexible Connectors

Flexible connectors are provided for Cable Bus enclosure bends or connections where there are small and uncertain angles, or if there are expected vibrations at the connection point. The flexible connectors are manufactured as two connection flanges placed back-to-back with a rubber bellows between them that will act as the flexible element.

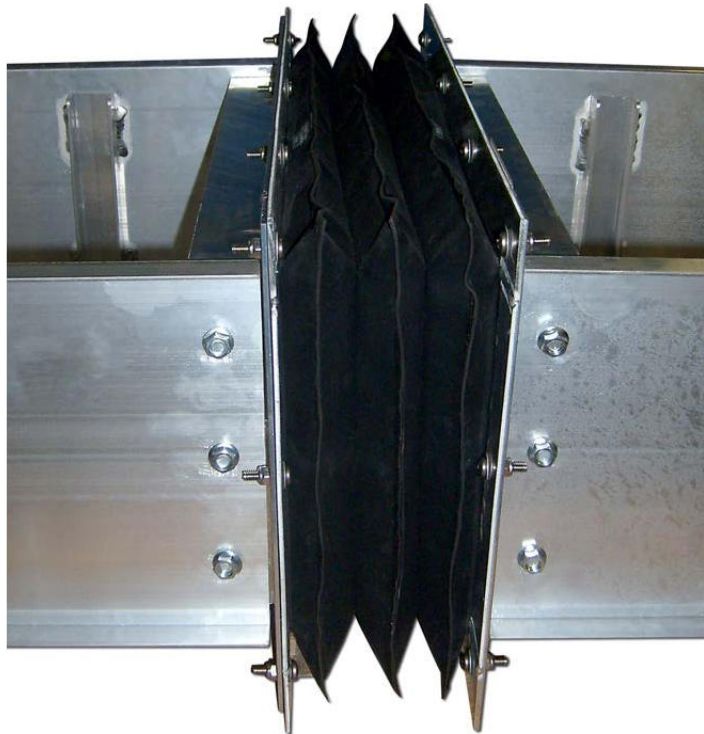

ABOVE—Factory standard *flexible connector* for seismically active job sites or vibration concerns.  
LEFT—Interior of a typical *tap box* showing conductors and terminations.

### Adapter Bus Bars

Adapter bus bars are items that may be required when the available terminal points of an equipment do not fit with the cable terminals. This situation sometimes occur when the project involves retrofitting older equipment or connecting Cable Bus to an equipment that was previously connected to rigid bus ducts. Adapter bus bars are designed and fabricated in order to accommodate the equipment's terminal hole pattern on one side, and the hole pattern of the cable termination lugs on the other end.

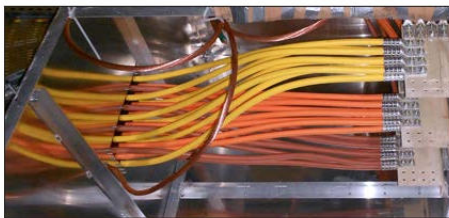

## ENGINEERING CALCULATIONS & TESTS

THE ENCLOSURE OF A CABLE BUS SYSTEM IS DESIGNED TO WITHSTAND UP TO 100 KA SYMMETRICAL SHORT-CIRCUIT CURRENT.

The cable configuration is designed to balance the current in each individual conductor and allow the cables to operate at their highest efficiency, where losses and imbalances between individual conductors are minimized. To ensure an efficient, dependable, high-quality installation, every Advanced Cable Bus system is fully engineered with particular emphasis placed on power cables, phasing arrangement and system balance, short-circuit capacity, and grounding requirements. Each one of these key design considerations must be analyzed separately to determine how it affects the design of the overall electrical system.

### SHORT-CIRCUIT CAPACITY

A Cable Bus system must be able to withstand the mechanical forces created by short-circuit currents. These forces are transferred from the conductors to the cable supports. The support elements in an Advanced Cable Bus system include the cable support blocks, Short-circuit braces and enclosure.

Short-circuit currents are made up of two parts: a symmetrical AC component and a rapidly decreasing DC component. Cable Bus systems are designed to have the mechanical strength to withstand the maximum instantaneous current and the symmetrical current which may last several cycles. The symmetrical current is the actual value that the circuit breaker will interrupt.

Since Cable Bus systems are often used for main feeder connections (e.g. substation or generator to switchgear, load centers and high voltage machines), the available short-circuit current will be that of the utility or generator supply through the transformers. In some cases, the Cable Bus system feeds large motors, and the motor contribution to potential short-circuit forces must also be considered. Numerous tables are available listing motor contributions for various operating conditions.

### SHORT-CIRCUIT TESTS & DATA

The tests performed on a prototype 15kV 4000A Cable Bus were conducted similar to the tests outlined in IEEE C37.23. The tests were conducted on a 3 phase, 60 Hz circuit. One end of the Cable Bus was connected to the source terminals, and the other was short-circuited to create a three phase bolted fault.

AB-COPE Cable Bus systems have been subjected to currents of 100,000 RMS symmetrical amperes with instantaneous peaks greater than 200,000 amperes. The Cable Bus system withstood the mechanical forces of the test without any damage to the cables, support blocks or enclosure. We are also able to supply type test reports, which demonstrate the short-circuit withstand capabilities and temperature rise data of a prototypical Cable Bus system.



ABOVE—A short-circuit test being run on an Abcope Cable Bus system.



ABOVE—A temperature rise test being run on an Abcope Cable Bus system.

### TEMPERATURE RISE TESTS & DATA

Temperature rise testing based on the IEEE C37.23 standard is performed on Cable Bus prototypes in order to demonstrate the Cable Bus system's ability to operate without exceeding temperature rise limits. These tests also act as proof that the ampacity calculations and temperature rise calculations are a valid approximation of the physical system. The testing is done at a third-party lab and is witnessed. For system ratings that were not tested, Advanced Cable Bus can provide heat-rise calculations, based on the client's installation configuration, showing the temperature rise of the conductors. Test reports of physically tested systems are available upon request. Please contact the factory for more information.

## CABLE BUS SYSTEM CALCULATIONS

Inductive Reactance calculations are available for every project. Based on the Carson's Line method of calculation and written using MATLAB codes and actual cable data, the Inductive Reactance Program outputs include the amount of current distributed through each cable, voltage drops, power losses, three-phase impedance and symmetrical component impedances. Please contact the factory for more information.

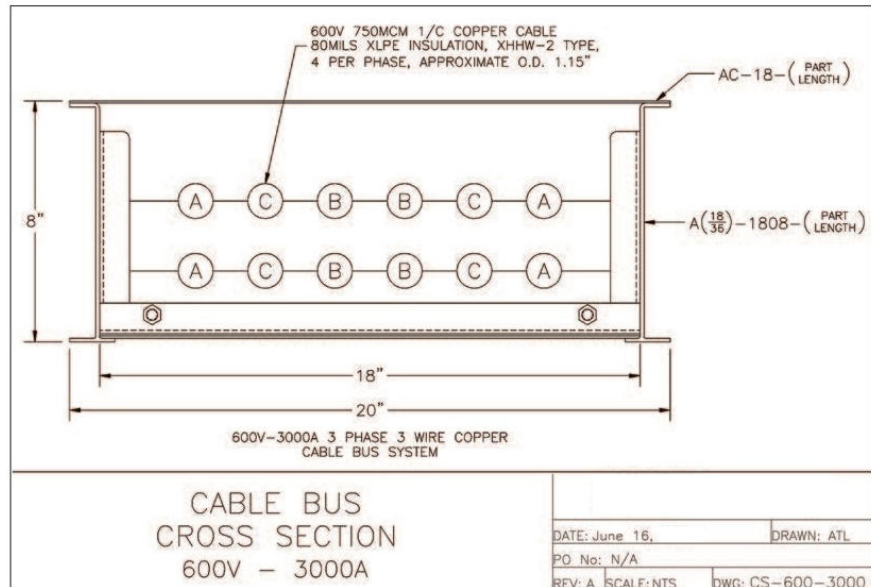

## SYSTEM BALANCE & PARALLEL CONDUCTORS

The spacing of the conductors in a Cable Bus system is one cable diameter (i.e. one to three inches). The objective of the Cable Bus design is to obtain the optimum balance for an electrical circuit using parallel conductors with no transposition and minimal imbalance.

AB-COPE Cable Bus is designed for balance of conductors within a phase (intra-phase) and balance between the phases (interphase). Many phasing arrangements will provide inter-phase balance of currents due to the load impedance, but the majority of these phasing arrangements do not provide intra-phase current imbalance. The Advanced Cable Bus design provides a phasing arrangement that achieves inter-phase current balance, as well as intra-phase current balance, therefore reducing the amount of parallel conductor imbalance to a minimum. This helps prevent hot spots in the electrical circuits that can be caused by cables in the same phase being unbalanced.

Parallel conductors (more than one per phase) can be used to an advantage in Cable Bus systems where large conductor sizes are encountered. The ampacity per circular mil of conductor decreases as the circular mil of conductor increases. Smaller conductors running parallel are more flexible during installation and have greater current carrying capability than fewer, larger conductors.

## GROUNDING CONSIDERATIONS

An AB-COPE Cable Bus system must protect both life and property against faults caused by electrical disturbances. Lightning, electrical system failures and failures in the system's corrective equipment all constitute possible fault hazard locations. For this reason, all metal enclosures of the system, as well as non-current carrying or neutral conductors, should be tied together and reduced to a common potential. This includes the structural steel of the building, water, steam and gas piping.

All AB-COPE Cable Bus systems should be grounded to the substation or building ground grid through the Cable Bus support materials. Cable Bus should also be grounded to the equipment or switchgear enclosure by means of the connection accessory.

It is an accepted fact that ground currents tend to concentrate near power conductors and that cable enclosures take a large portion of the ground currents; therefore, it is important to consider Cable Bus as a major carrier of ground currents. The Cable Bus enclosure is designed to be able to carry large ground currents and is grounded in accordance with NEC 250.



ABOVE—Cable Bus system with external grounding cable and firestop/wall seal.

## CABLE BUS VS. ALTERNATIVES

■ **CABLE BUS IS A COMPETITIVE** alternative to conventional, non-segregated phase bar bus, cable tray with armored cable, and conduit and wire systems. This is because of its lower cost, higher reliability, greater flexibility, easier installation and longer life expectancy.

■ **THE TABLE TO THE RIGHT** quantifies the difference in ampacity accommodated by Cable Bus systems, as compared to cables in tray and cables in conduit. Cable Bus accommodates significantly higher ampacities than both alternatives for every system rating and conductor size listed.

### AMPACITY COMPARISON: Advanced Cable Bus vs. the Field

| SYSTEM RATING | CONDUCTOR SIZE | ADVANCED CABLE BUS SYSTEMS | INTERLOCKED, ARMORED CABLE IN TRAY | 3 SINGLE-CONDUCTOR CABLES IN CONDUIT/AIR |
|---------------|----------------|----------------------------|------------------------------------|--|
| 600V          | 500 MCM        | 637 AMPS                   | 405 AMPS                           | 477 AMPS                                 |
|               | 750 MCM        | 805 AMPS                   | 500 AMPS                           | 598 AMPS                                 |
|               | 1000 MCM       | 960 AMPS                   | 585 AMPS                           | 689 AMPS                                 |
| 5kV           | 500 MCM        | 688 AMPS                   | 425 AMPS                           | 473 AMPS                                 |
|               | 750 MCM        | 889 AMPS                   | 525 AMPS                           | 579 AMPS                                 |
|               | 1000 MCM       | 1061 AMPS                  | 590 AMPS                           | 659 AMPS                                 |
| 15kV          | 500 MCM        | 678 AMPS                   | 470 AMPS                           | 481 AMPS                                 |
|               | 750 MCM        | 872 AMPS                   | 570 AMPS                           | 588 AMPS                                 |
|               | 1000 MCM       | 1040 AMPS                  | 650 AMPS                           | 677 AMPS                                 |

#### When compared with conduit-and-wire

systems and cables-in-tray systems, Cable Bus systems will require fewer cables or smaller cables in order to carry the same current rating. This is because Cable Bus systems are designed with maintained spacing and ventilation that allows the cables to operate with the free-air rating ampacity, higher than the allowable ampacities for other systems. Cable Bus systems also use less conductor mass than the bus duct systems of the same rating.

#### The cost of installing a Cable Bus

system is comparable to installing similarly sized cables in tray. The main difference is that Cable Bus systems include cable support blocks and top covers on the enclosures. Cables in tray, on the other hand, often require fasteners to hold cables in place. Cables in tray also require greater quantities of cable to transmit the same amount of power. The main labor savings for Cable Bus systems compared to cables-in-tray and conduit-and-wire systems is the reduction in number of cables being installed.

The cost of enclosures for Cable Bus systems is often higher than for cables in tray or cables in conduit. Whereas the latter systems are produced as bulk commodities, Cable Bus systems are uniquely engineered per project. These higher enclosure costs, however, are more than offset by the smaller sizes and lesser quantities of conductors that Cable Bus systems require.

Cable Bus is the only type of installation for which the manufacturer's design guarantees the conductor currents will have the best possible balance of individual conductor loading.

Additionally, Cable Bus has

marked flexibility in routing and design. Odd lengths, uncertain connection points, and non-standard elbow angles are not an issue. Cable Bus systems can also feature hinged splice plate, to accommodate movement if necessary. Additional cable and extra enclosure parts are supplied standard with every project to accommodate for any last minute variations encountered in the field.

Similarly to other power distribution feeder systems, Cable Bus can be used for medium- as well as low-voltage applications. Cable Bus systems can be designed to carry 5,000 Amps and higher, similar to bus ducts and cables in conduits.

Enclosure size is the area in which Cable Bus systems really begin to pull away from the pack. The largest Cable Bus system thus far measured 26" (66.04 cm) wide × 12" (30.48 cm) tall. A bus duct system with comparable ratings typically measures 36" (91.44 cm) wide × 18" (45.72 cm) tall. Cables in tray with ratings up to 5,000 Amps often require multiple tray runs. At higher current ratings, cables in conduit require additional space due to the additional conduit runs needed.

Fault current withstand testing for Cable Bus systems follows the same standard as bus duct systems; the two systems therefore have

comparable fault current withstand capabilities. By contrast, cables in tray and cables in conduit require special cable cleats or special installation techniques in order to meet higher short-circuit withstand parameters.

Cable Bus systems are similar to bus duct systems in that all engineering drawings and electrical calculations corresponding to the finished Cable Bus run(s) are provided standard to the customer.

In sum, the strength, durability, and reliability of Cable Bus systems are similar to those of rigid bus ducts, but Cable Bus systems are more compact and flexible. ■

## TYPICAL SYSTEM CROSS-SECTIONS & DIMENSIONS

### 600V ENCLOSURE DIMENSIONS BY AMPACITY

| FIGURE   | TYPICAL AMPACITY | ENCLOSURE HEIGHT | NOMINAL (BOTTOM COVER) WIDTH | TOP COVER WIDTH | NUMBER OF POWER CABLES | CONDUCTOR SIZE |
|----------|------------------|------------------|------------------------------|-----------------|------------------------|----------------|
| <b>A</b> | 800 Amps         | 6"               | 10"                          | 12"             | 3                      | 300 MCM        |
| <b>B</b> | 1200 Amps        | 6"               | 10"                          | 12"             | 6                      | 500 MCM        |
| <b>B</b> | 1600 Amps        | 6"               | 10"                          | 12"             | 6                      | 750 MCM        |
| <b>C</b> | 2000 Amps        | 6"               | 16"                          | 18"             | 12                     | 500 MCM        |
| <b>C</b> | 2500 Amps        | 6"               | 16"                          | 18"             | 12                     | 500 MCM        |
| <b>D</b> | 3000 Amps        | 6"               | 18"                          | 20"             | 12                     | 750 MCM        |
| <b>E</b> | 3500 Amps        | 10"              | 16"                          | 18"             | 15                     | 750 MCM        |
| <b>F</b> | 4000 Amps        | 10"              | 18"                          | 20"             | 18                     | 750 MCM        |
| <b>G</b> | 4500 Amps        | 10"              | 20"                          | 22"             | 21                     | 750 MCM        |
| <b>H</b> | 5000 Amps        | 10"              | 24"                          | 26"             | 24                     | 750 MCM        |
| <b>I</b> | 6000 Amps        | 10"              | 24"                          | 26"             | 27                     | 750 MCM        |

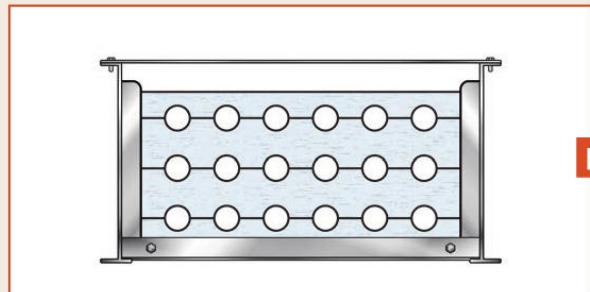
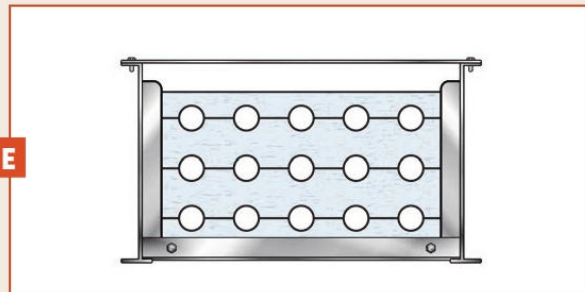
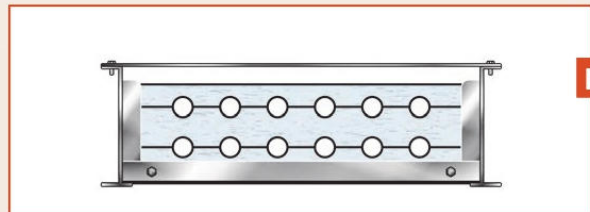
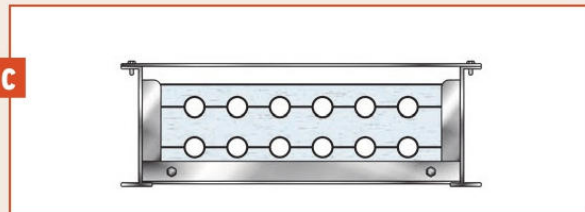
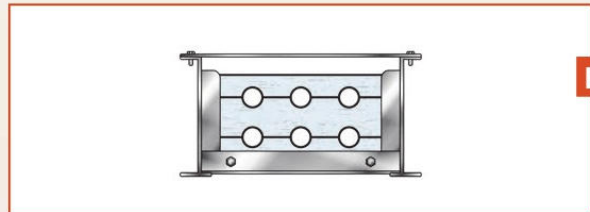
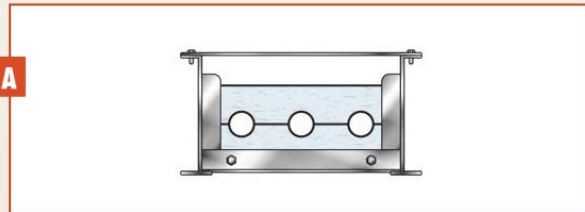

## 5KV ENCLOSURE DIMENSIONS BY AMPACITY

| FIGURE   | TYPICAL AMPACITY | ENCLOSURE HEIGHT | NOMINAL (BOTTOM COVER) WIDTH | TOP COVER WIDTH | NUMBER OF POWER CABLES | CONDUCTOR SIZE |
|----------|------------------|------------------|------------------------------|-----------------|------------------------|----------------|
| <b>A</b> | 800 Amps         | 6"               | 10"                          | 12"             | 3                      | 300 MCM        |
| <b>B</b> | 1200 Amps        | 6"               | 10"                          | 12"             | 6                      | 500 MCM        |
| <b>J</b> | 1600 Amps        | 8"               | 10"                          | 12"             | 6                      | 750 MCM        |
| <b>K</b> | 2000 Amps        | 8"               | 18"                          | 20"             | 12                     | 500 MCM        |
| <b>K</b> | 2500 Amps        | 8"               | 18"                          | 20"             | 12                     | 500 MCM        |
| <b>L</b> | 3000 Amps        | 8"               | 20"                          | 22"             | 12                     | 750 MCM        |
| <b>M</b> | 3500 Amps        | 10"              | 18"                          | 20"             | 15                     | 750 MCM        |
| <b>N</b> | 4000 Amps        | 10"              | 24"                          | 26"             | 18                     | 750 MCM        |
| <b>O</b> | 4500 Amps        | 10"              | 24"                          | 26"             | 21                     | 750 MCM        |
| <b>P</b> | 5000 Amps        | 10"              | 26"                          | 28"             | 24                     | 750 MCM        |

**NOTE:** All cross-sections and dimensions are based on **3 Phase/3 Wire systems**, without system ground, with a standard operating temperature of 90°C (194°F) in a 40°C (104°F) ambient environment. For information on other system ratings and non-standard site conditions, please contact our factory.

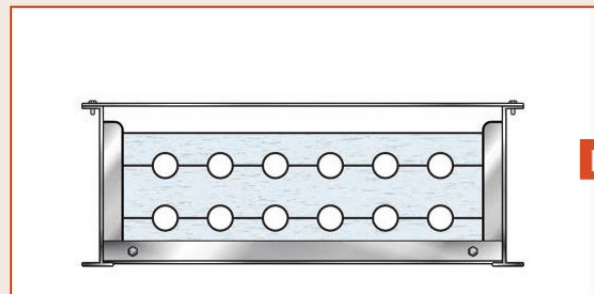
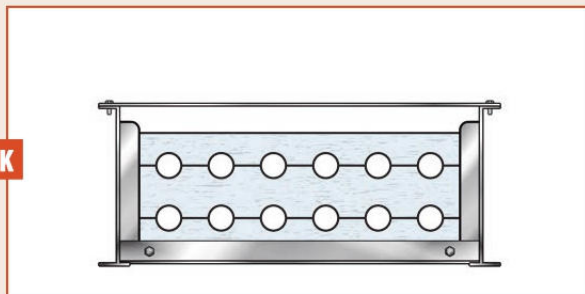
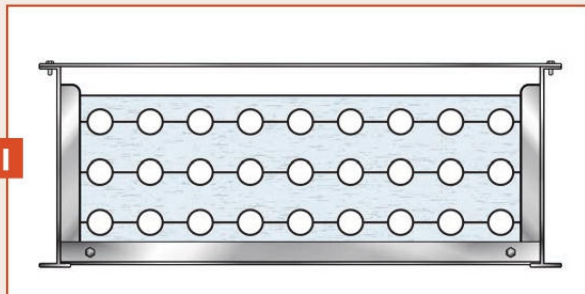
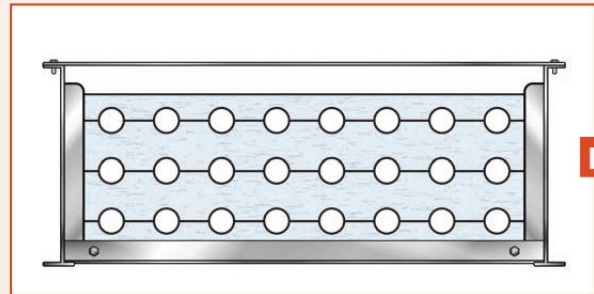
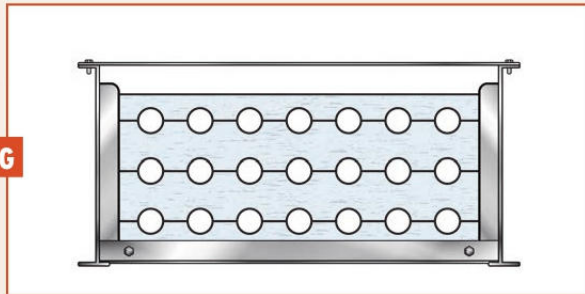

## 15KV ENCLOSURE DIMENSIONS BY AMPACITY

| FIGURE   | TYPICAL AMPACITY | ENCLOSURE HEIGHT | NOMINAL (BOTTOM COVER) WIDTH | TOP COVER WIDTH | NUMBER OF POWER CABLES | CONDUCTOR SIZE |
|----------|------------------|------------------|------------------------------|-----------------|------------------------|----------------|
| <b>A</b> | 800 Amps         | 6"               | 10"                          | 12"             | 3                      | 300 MCM        |
| <b>J</b> | 1200 Amps        | 8"               | 10"                          | 12"             | 6                      | 500 MCM        |
| <b>Q</b> | 1600 Amps        | 8"               | 12"                          | 14"             | 6                      | 750 MCM        |
| <b>R</b> | 2000 Amps        | 8"               | 24"                          | 26"             | 12                     | 500 MCM        |
| <b>R</b> | 2500 Amps        | 8"               | 24"                          | 26"             | 12                     | 500 MCM        |
| <b>R</b> | 3000 Amps        | 8"               | 24"                          | 26"             | 12                     | 750 MCM        |
| <b>S</b> | 3500 Amps        | 12"              | 18"                          | 20"             | 15                     | 750 MCM        |
| <b>T</b> | 4000 Amps        | 12"              | 24"                          | 26"             | 18                     | 750 MCM        |
| <b>U</b> | 4500 Amps        | 12"              | 24"                          | 26"             | 21                     | 750 MCM        |
| <b>V</b> | 5000 Amps        | 12"              | 28"                          | 30"             | 24                     | 750 MCM        |

**NOTE:** All cross-sections and dimensions are based on **3 Phase/3 Wire systems**, without system ground, with a standard operating temperature of 90°C (194°F) in a 40°C (104°F) ambient environment. For information on other system ratings and non-standard site conditions, please contact our factory.

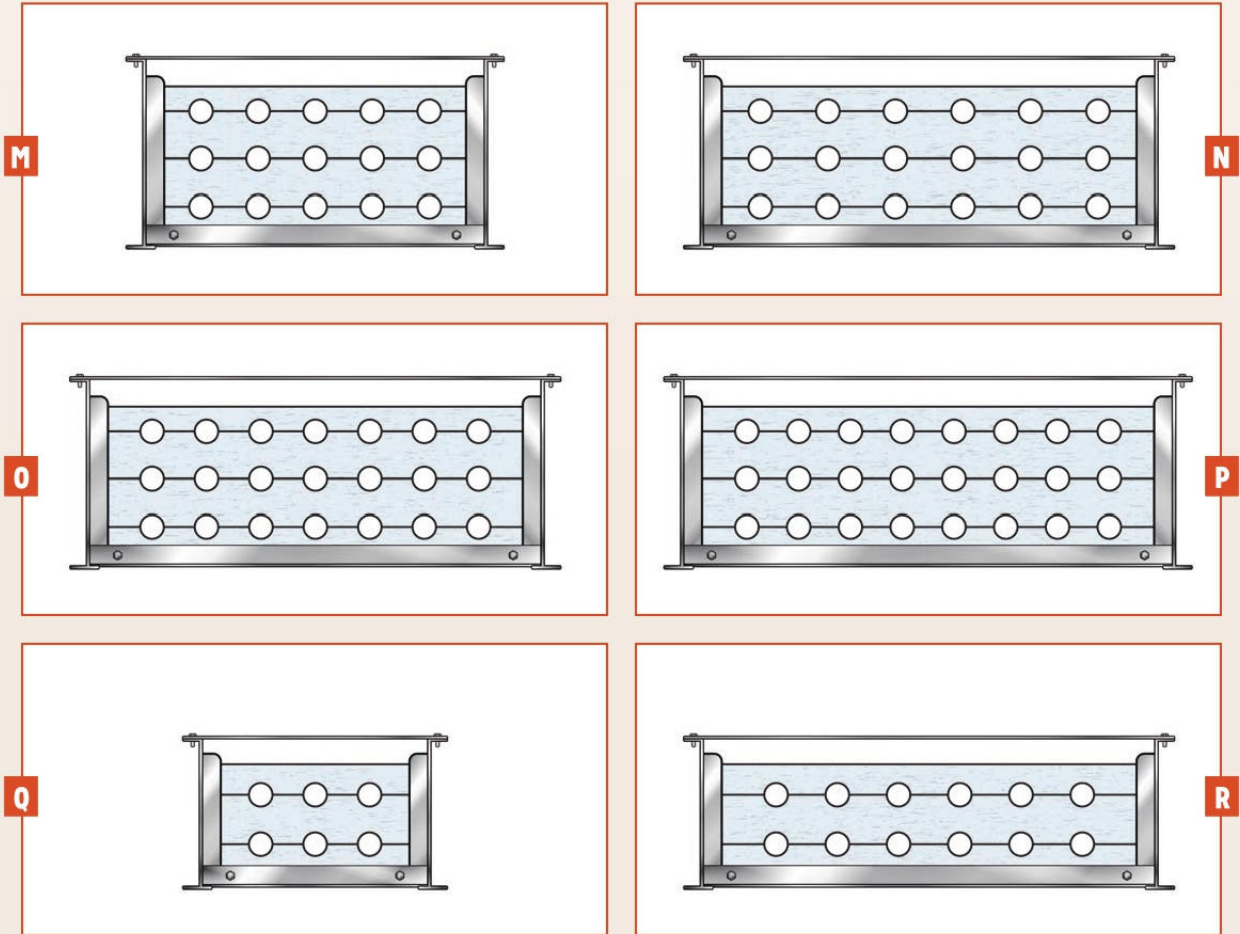

IDENTICAL DESIGNS AS MANUFACTURED IN THE UNITED STATES OF AMERICA

## 35KV ENCLOSURE DIMENSIONS BY AMPACITY

| FIGURE   | TYPICAL AMPACITY | ENCLOSURE HEIGHT | NOMINAL (BOTTOM COVER) WIDTH | TOP COVER WIDTH | NUMBER OF POWER CABLES | CONDUCTOR SIZE |
|----------|------------------|------------------|------------------------------|-----------------|------------------------|----------------|
| <b>W</b> | 800 Amps         | 6"               | 12"                          | 14"             | 3                      | 500 MCM        |
| <b>Q</b> | 1200 Amps        | 8"               | 12"                          | 14"             | 6                      | 500 MCM        |
| <b>X</b> | 1600 Amps        | 8"               | 18"                          | 20"             | 9                      | 500 MCM        |
| <b>R</b> | 2000 Amps        | 8"               | 18"                          | 20"             | 12                     | 500 MCM        |
| <b>R</b> | 2500 Amps        | 8"               | 24"                          | 26"             | 12                     | 500 MCM        |
| <b>S</b> | 3000 Amps        | 12"              | 18"                          | 20"             | 15                     | 500 MCM        |
| <b>T</b> | 3500 Amps        | 12"              | 24"                          | 26"             | 18                     | 500 MCM        |

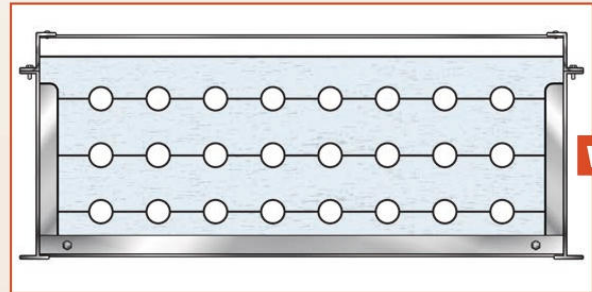
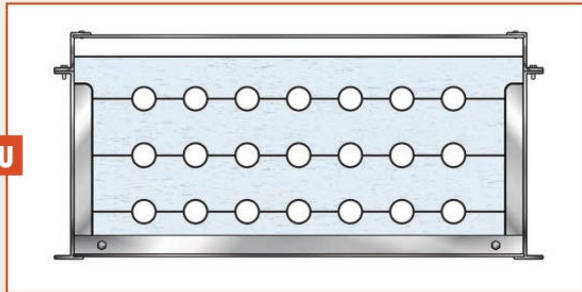
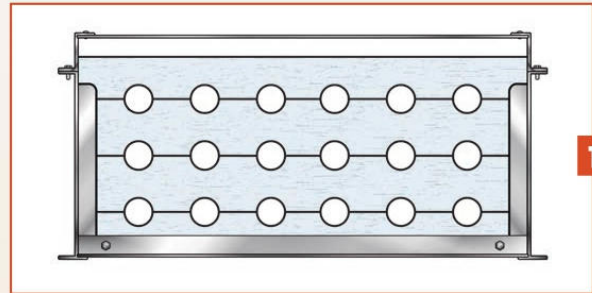
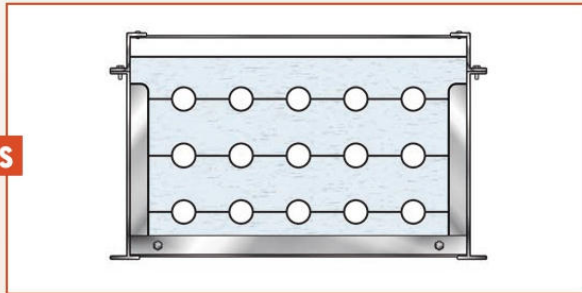

**FIGURES S, T, U, and V:** The side members of our 12" tall Cable Bus enclosures are assembled in two parts. "Z" members are used to increase the height of our standard No. 1 Form Side Rails without compromising structural integrity or electrical continuity.

**FIGURE X:** There are 9 power cables in our 35kV-1600A and 35kV-2000A systems. The 10th bore in the cable support blocks is left empty.

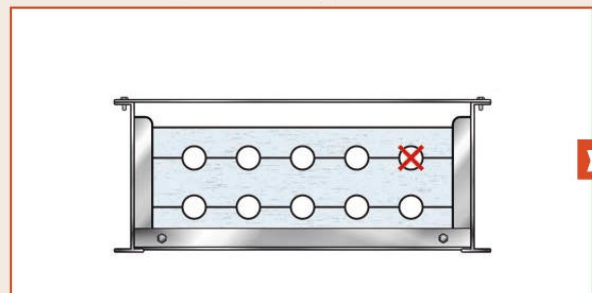
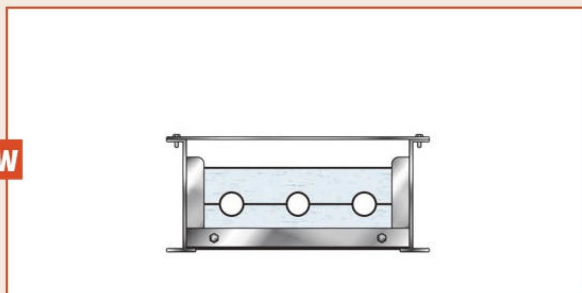

## TYPICAL ELBOW/OFFSET DIAGRAMS & DIMENSIONS

● **HORIZONTAL & VERTICAL ELBOWS ARE CURVED** to follow the bending radius of the power cables perfectly. The inside radius of the elbows is determined according to the minimum bending radius of the selected power cables and design space requirements. Standard horizontal and vertical elbows come in 15°, 30°, 45°, 60° and 90° bends. Custom elbows are also available to meet your specific job requirements.

● **THE INSIDE RADIUS OF AN ELBOW** shall not be less than the minimum bending radius of the power cables it will house. This is true for both horizontal and vertical elbows. Corresponding inside and outside radii listed in the tables above are typical for elbows of all degree measures.

### TYPICAL HORIZONTAL ELBOW DIMENSIONS

| NOMINAL WIDTH | TOP COVER WIDTH | INSIDE RADIUS | OUTSIDE RADIUS |
|---------------|-----------------|---------------|----------------|
| 10"           | 12"             | 12"           | 22"            |
| 10"           | 12"             | 18"           | 28"            |
| 10"           | 12"             | 24"           | 34"            |
| 10"           | 12"             | 36"           | 46"            |
| 12"           | 14"             | 12"           | 24"            |
| 12"           | 14"             | 18"           | 30"            |
| 12"           | 14"             | 24"           | 36"            |
| 12"           | 14"             | 36"           | 48"            |
| 16"           | 18"             | 12"           | 28"            |
| 16"           | 18"             | 18"           | 34"            |
| 16"           | 18"             | 24"           | 40"            |
| 16"           | 18"             | 36"           | 52"            |
| 18"           | 20"             | 12"           | 30"            |
| 18"           | 20"             | 18"           | 36"            |
| 18"           | 20"             | 24"           | 42"            |
| 18"           | 20"             | 36"           | 54"            |
| 20"           | 22"             | 12"           | 32"            |
| 20"           | 22"             | 18"           | 38"            |
| 20"           | 22"             | 24"           | 44"            |
| 20"           | 22"             | 36"           | 56"            |
| 24"           | 26"             | 12"           | 36"            |
| 24"           | 26"             | 18"           | 42"            |
| 24"           | 26"             | 24"           | 48"            |
| 24"           | 26"             | 36"           | 60"            |

**NOTE:** The *nominal width* of a *horizontal elbow* refers to the width of the *bottom cover* of the Cable Bus enclosure. Corresponding top covers are 2" wider, enabling them to span the 1" flange at the top of each No. 1-Form Side Rail. The positions of these flanges are indicated on the *Typical 90° Horizontal Elbow* diagram (opposite page) by dashed lines. Top and bottom cover widths are listed in the table above for your convenience.

### TYPICAL VERTICAL ELBOW DIMENSIONS

| ENCLOSURE HEIGHT | INSIDE RADIUS | OUTSIDE RADIUS |
|------------------|---------------|----------------|
| 6"               | 12"           | 18"            |
| 6"               | 18"           | 24"            |
| 6"               | 24"           | 30"            |
| 6"               | 36"           | 42"            |
| 8"               | 12"           | 20"            |
| 8"               | 18"           | 26"            |
| 8"               | 24"           | 32"            |
| 8"               | 36"           | 44"            |
| 10"              | 12"           | 22"            |
| 10"              | 18"           | 28"            |
| 10"              | 24"           | 34"            |
| 10"              | 36"           | 46"            |
| 12"              | 12"           | 24"            |
| 12"              | 18"           | 30"            |
| 12"              | 24"           | 36"            |
| 12"              | 36"           | 48"            |



#### VERTICAL OUTSIDE ELBOW:

The top cover of the Cable Bus enclosure is positioned along the *outside radius* of the elbow, as shown on the *Typical 90° Vertical Outside Elbow* diagram (opposite page, left).



#### VERTICAL INSIDE ELBOW:

The top cover of the Cable Bus enclosure is positioned along the *inside radius* of the elbow, as shown on the *Typical 90° Vertical Inside Elbow* diagram (opposite page, right).

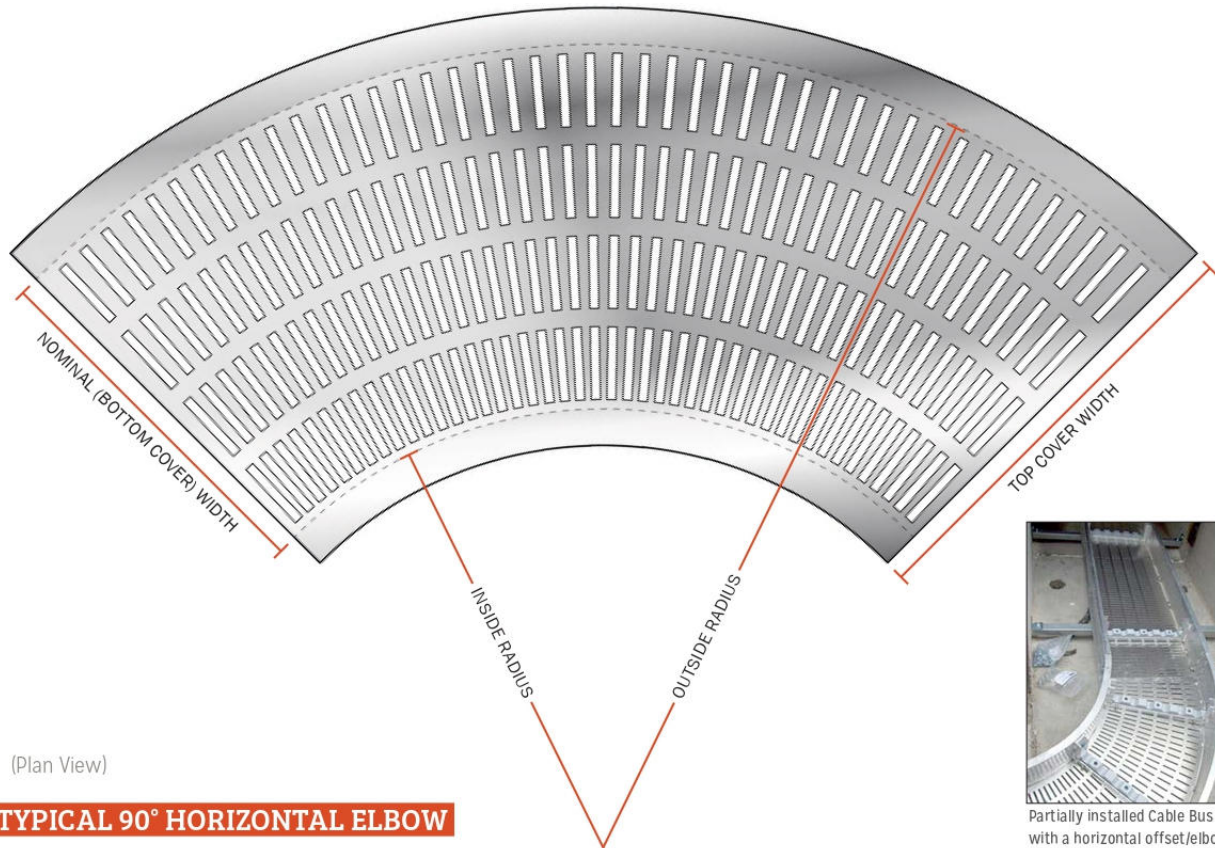

**TYPICAL 90° VERTICAL OUTSIDE ELBOW**

(Elevation View)

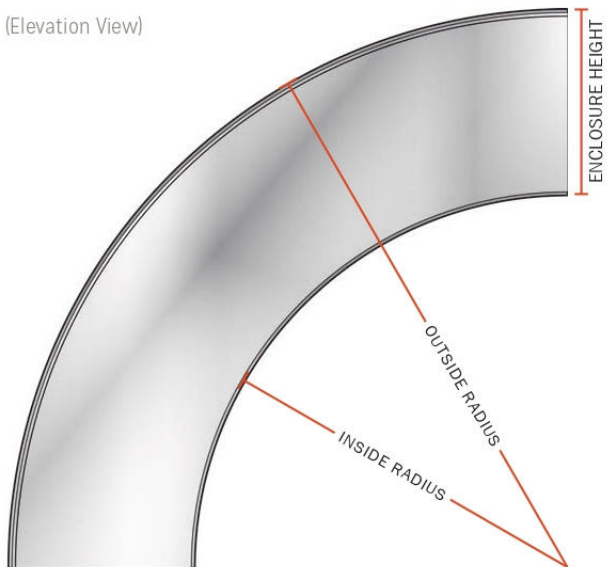

**TYPICAL 90° VERTICAL INSIDE ELBOW**

(Elevation View)

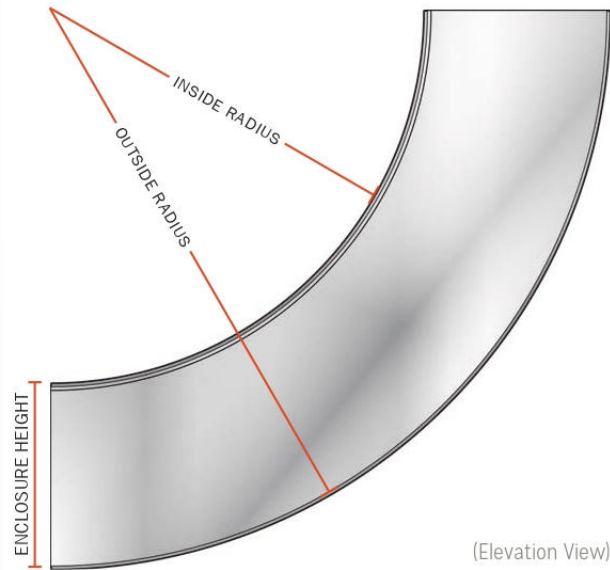

## STANDARD CABLE BUS SYSTEM SPECIFICATIONS

### GENERAL CABLE BUS SPECIFICATIONS

**1.** A complete, metal-enclosed Cable Bus system will be provided, including enclosure sections, insulated conductors, and all necessary accessories. Accessories may include, but are not limited to: fittings, equipment seals, wall/floor seals, fire stops, termination boxes, tap boxes, connection (bus end) flanges, termination lugs, termination kits, grounding accessories, and installation hardware.

The Cable Bus system and all of its components will be suitable for indoor and outdoor use. Adequate ventilation, and a minimum distance of one (1) cable diameter between conductors, will be maintained throughout the system.

**2.** All elements of the Cable Bus enclosure will be fabricated so as to eliminate any sharp edges that might damage conductor insulation or injure personnel.

**3.** The Cable Bus system will be designed and manufactured in the Kingdom of Saudi Arabia by Abcope Cable Bus, Inc.

### CONSTRUCTION SPECIFICATIONS

**1.** The Cable Bus enclosure will be aluminum\*, of welded construction and ventilated design, with No. 1 Form Side Rails manufactured from extruded, 6063-T6 aluminum alloy. The maximum allowed stress to be used in design is 10,000 PSI.

**2.** Top and bottom covers of the Cable Bus enclosure will be slotted for ventilation. Ventilation openings will comprise 50% of the covers' surface area, and openings will be sized to prevent a quarter-inch (1/4") rod from penetrating the Cable Bus enclosure. Top covers will be fastened to the Cable Bus enclosure with No. 10 self-drilling screws, spaced 24 inches (on centers), allowing the covers to be easily removed for system inspection. Bottom covers will be factory installed and welded to the adjacent Side Rails to form an integral part of the Cable Bus enclosure.

**3.** Each system's elbows (offsets) will be designed to accommodate the cable type selected for that system. In no instance will the inside radius of an elbow be less than the minimum bending radius of the cable it will house.

**4.** The splice joints that span adjoining sections of the Cable Bus enclosure will be reinforced with high-pressure bolts to ensure that structural integrity is maintained.

**5.** Cable support blocks will be designed in segments, and will maintain a minimum distance of one (1) cable diameter between conductors in both vertical and horizontal planes. This spacing will allow the Cable Bus system to obtain a Free Air rating.

The Cable Bus enclosure will be designed with cable support blocks throughout, spaced 36 inches (on centers) in horizontal straight sections, and 18 inches (on centers) in vertical straight sections and elbows. The cable support blocks will prevent the power cables from moving and/or incurring damage during short-circuit conditions. Cable Bus systems will be rated to withstand short-circuit forces of 100kA (100,000 amperes) RMS symmetrical.

### ELECTRICAL SPECIFICATIONS

**1.** The Side Rails of the Cable Bus enclosure will be capable of carrying a continuous current rating of 1kA (1,000 amperes) without exceeding a 40°C temperature rise above ambient. Resistance across Cable Bus enclosure splice joints will not exceed 50 microhms. The Cable Bus enclosure will be grounded at sufficient intervals to prevent potential above ground from occurring in the event of a fault.

**2.** Current conductors will be single conductor cables, insulated for an operating temperature of 90°C (in wet or dry locations) in accordance with ICEA P-46-426 interim STD #1 & 2 of ICEA publication #S-66-524, based on the specified system voltage and amperage.

**3.** Conductors within the Cable Bus enclosure will have a specific phasing arrangement designed to minimize current imbalance between conductors, maintain a low-impedance power system, and minimize inter-phase and intra-phase imbalance.

**4.** Interleaving of conductors within the Cable Bus enclosure will not be permitted. All current-carrying conductors are to be continuous (without any intermediate splices), and are to be pulled into place after the Cable Bus enclosure has been installed. Electrical connections will be made at equipment and/or tap points only. All cable termination materials will be furnished by Advanced Cable Bus, Inc.

**5.** Current balance and temperature rise calculations will be made available upon request, in support of Advanced Cable Bus, Inc. Electrical Specifications # 2 & 3 (above).

\* Anodized aluminum and steel (hot-dip galvanized after fabrication) enclosures are also available. Please contact our office for more information.

## QUALIFICATIONS, STANDARDS & PROTOCOLS

● **CABLE BUS IS DEFINED** by the National Electric Code (Article 370) for use in the US, and the design and testing of Cable Bus systems by Advanced Cable Bus, Inc. is based on the IEEE C37.23 standard which covers the testing for busways, switchgear, and controlgear for short-circuit and temperature rise. Cable Bus subcomponents are also designed and manufactured in accordance with their respective standards.

● **ABCOPE CABLE BUS, INC.** can make design modifications within the listed parameters in order to meet client specifications and accommodate special requirements. Please note that Cable Bus systems can be sold and installed in locations that require compliance with IEC standards as well. Although there are no IEC standards that explicitly cover Cable Bus systems, Abcope Cable Bus can select components based on their adherence to relevant IEC standards and design a suitable system. Please contact the factory for additional information.

### DESIGN STANDARDS FOR CABLE BUS SYSTEMS & COMPONENTS

| SYSTEM OR COMPONENT  | QUALIFICATIONS & STANDARDS   |
|--|--|
| <b>Cable Bus System—DESIGN &amp; AMPACITY</b>  | NEC 370<br>NEC Table 310.15(B)(17)<br>CSA CEC Tables 1 and 5A<br>IPCEA P-46-426, IEEE 835<br>NEMA VE-1, NEMA VE-2  |
| <b>Cable Bus System—SHORT-CIRCUIT &amp; TEMPERATURE RISE</b>   | IEEE C37.23<br>CSA CEC Part 1, C22.2 No. 27-10 (see below)   |
| <b>POWER CABLES</b><br><br><i>Actual specifications vary on a project-by-project basis. List to the right is partial and includes medium voltage and low voltage cables.</i> | ASTM B-3, ASTM B-496<br>ICEA S-95-658, ICEA S-93-639,<br>ICEA S-97-682<br>AIEC CS8<br>NEMA WC-70, NEMA WC-74<br>UL 44, UL 854, UL 1581, UL 1072<br>IEEE 383, IEEE 1202<br>CSA FT1 and FT4, CSA C68.3 |
| <b>FIRE-RATED WALL PENETRATIONS</b>  | <i>Qualifications and test reports available from:</i><br>UL<br>CSA<br>American Bureau of Shipping (ABS)<br>Det Norske Veritas (DNV)<br>Lloyd's Register of Shipping<br>US Navy                      |
| <b>CABLE TERMINATION LUGS</b>  | UL 468A-468B<br>CSA Listed & Approved  |
| <b>SYSTEM GROUNDING</b>  | NEC 250  |
| <b>MEDIUM VOLTAGE CABLE TERMINATION</b>  | IEEE 48  |

RELIABLE, ALL-WEATHER, MAINTENANCE-FREE POWER DISTRIBUTION SYSTEMS

CUSTOM DESIGNED & MANUFACTURED IN THE KINGDOM OF SAUDI ARABIA



## UNDERWRITERS LABORATORIES

The components of each Cable Bus system are individually classified by Underwriters Laboratories (UL), Inc., including the system's power cables, cable terminations, firestops, and enclosure. UL does not have a separate classification for Cable Bus systems in their entirety, however, enclosure side rails are tested and classified by UL as a grounding path in accordance with NEC 250.



## CANADIAN STANDARDS ASSOCIATION

At the current time, there is no unified rule or passage in the CSA/Canadian Electrical Code that specifically controls the construction, approval, and certification of Cable Bus systems as a discrete product type. A CSA committee was formed in 2010 to add a rule for Cable Bus. This committee's membership includes Advanced Cable Bus, Inc., as well as other Cable Bus manufacturers. Cable Bus as a product utilizes many of the features of cable tray and busways, therefore its design features can be referenced to existing rules. Since there is no certification for Cable Bus as a field-assembled product at this time, CSA approval requires installed Cable Bus systems to be specially inspected. Please contact us for further details.



- AB-COPE Cable Bus employs an in-house Quality Assurance (QA) program based on ISO-9001 guidelines.
- QA program includes checkpoints and checklists for all projects and business activities, from proposal stages through delivery and system installation.
- System components not manufactured by Advanced Cable Bus are purchased from suppliers with proven Quality Assurance programs and ISO-9001 certification (if available).
- QA documents are available upon request.
- On-site inspection of projects is available if specified in contract terms.

**Rigorous inspections coupled with expert support ensure customer satisfaction.**

## REQUEST FOR QUOTE

■ Xerox this form and fill it out as completely as possible

### ■ CONTACT INFORMATION

FULL NAME: .....

ENGINEERING FIRM: .....

TELEPHONE: .....

FACSIMILE: .....

E-MAIL: .....

ADDRESS: .....

TODAY'S DATE: .....

### ■ PROJECT INFORMATION

PROJECT NAME: .....

PROJECT LOCATION: .....

BID DUE DATE: .....

DATE MATERIAL NEEDED: .....

### ■ SYSTEM INFORMATION

SYSTEM VOLTAGE: .....

SYSTEM AMPERAGE: .....

SYSTEM TYPE(S):  3 Phase / 3 Wire  
 3 Phase / 4 Wire, Full Neutral  
 3 Phase / 4 Wire, ..... % Neutral  
 Single Phase AC  
 2 Pole DC  
 Other (please specify): .....

CONDUCTOR MATERIAL:  Copper  Aluminum

CABLE SPECS (shielding, jacketing, etc): .....

GROUNDING REQUIREMENTS: .....

CABLE BUS FOOTAGE: ..... Total Feet  
..... Vertical Feet  
..... Horizontal Feet

### ■ PARTS & ACCESSORIES

*For each item listed below, please indicate the quantity required.*

Horizontal Elbow(s):  
..... 90° ..... 60° ..... 45° ..... 30° ..... 15°

Vertical Elbow(s):  
..... 90° ..... 60° ..... 45° ..... 30° ..... 15°

Wall Penetration Seal(s): .....

Wall Penetration Seal(s), Fire Rated: .....

Floor Penetration Seal(s): .....

Floor Penetration Seal(s), Fire Rated: .....

Equipment Seal(s): .....

Equipment Seal(s), Fire Rated: .....

Tap Box(es), Indoor: .....

Tap Box(es), Outdoor: .....

Termination Box(es), Indoor: .....

Termination Box(es), Outdoor: .....

### ■ ADDITIONAL INFORMATION

*If you have any additional information or specifications to include, please do so below.*

.....

.....

.....

.....

PHONE:  
+966 13 8086568

TOLL-FREE:  
+966 596455741

EMAIL:  
akma@abahsain.net

ADDRESS:  
2nd Industrial city,  
Dammam,  
Saudi Arabia

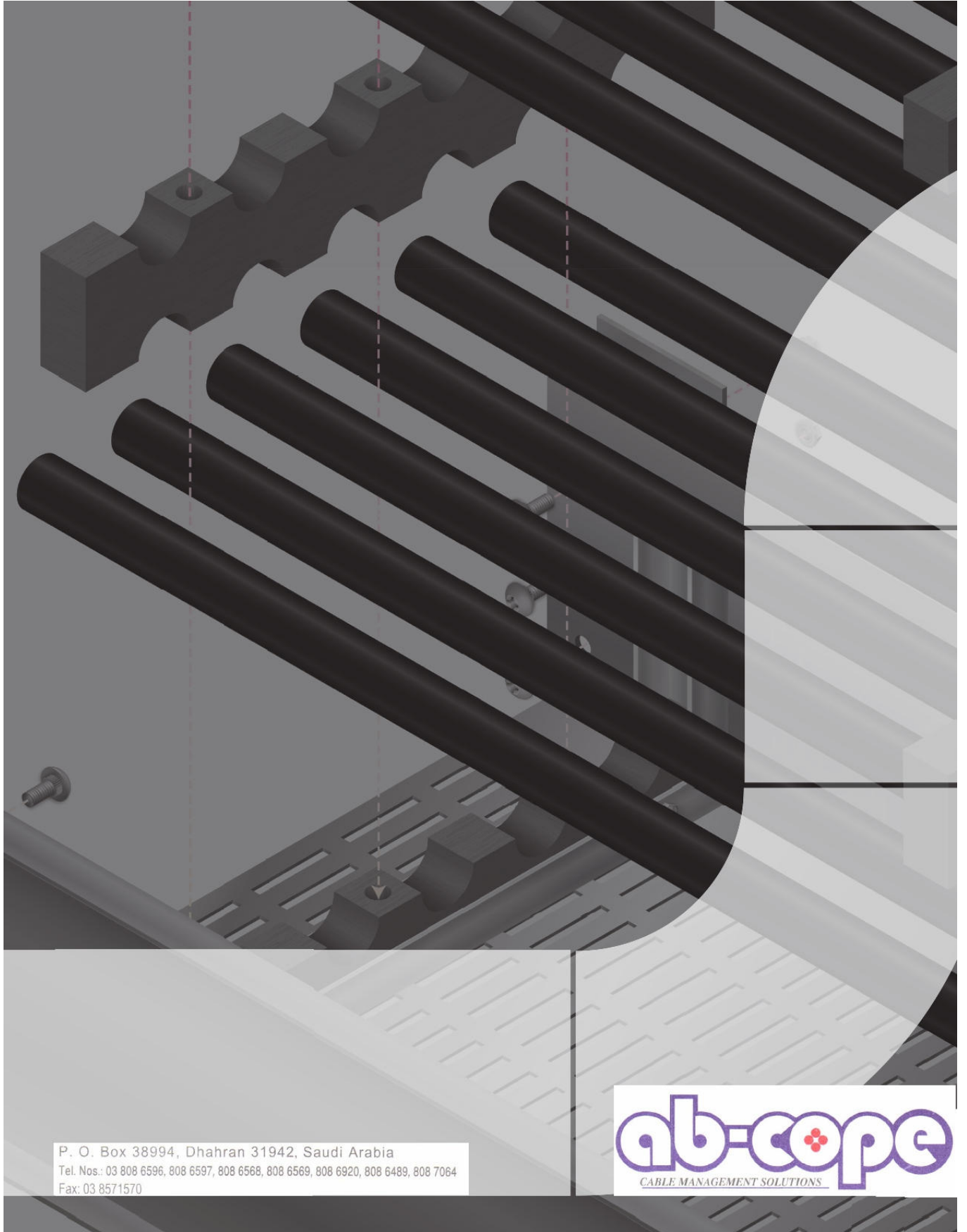

P. O. Box 38994, Dhahran 31942, Saudi Arabia  
Tel. Nos.: 03 808 6596, 808 6597, 808 6568, 808 6569, 808 6920, 808 6489, 808 7064  
Fax: 03 8571570





**ABAHSAIN-COPE S.A. LTD**  
**CABLE SUPPORT SOLUTIONS MANUFACTURER**

Makkah Street, Near SEC Grid Station, 2nd Dammam Industrial City W,  
 Dammam, Kingdom of Saudi Arabia

## Abahsain Cope - Direction Map

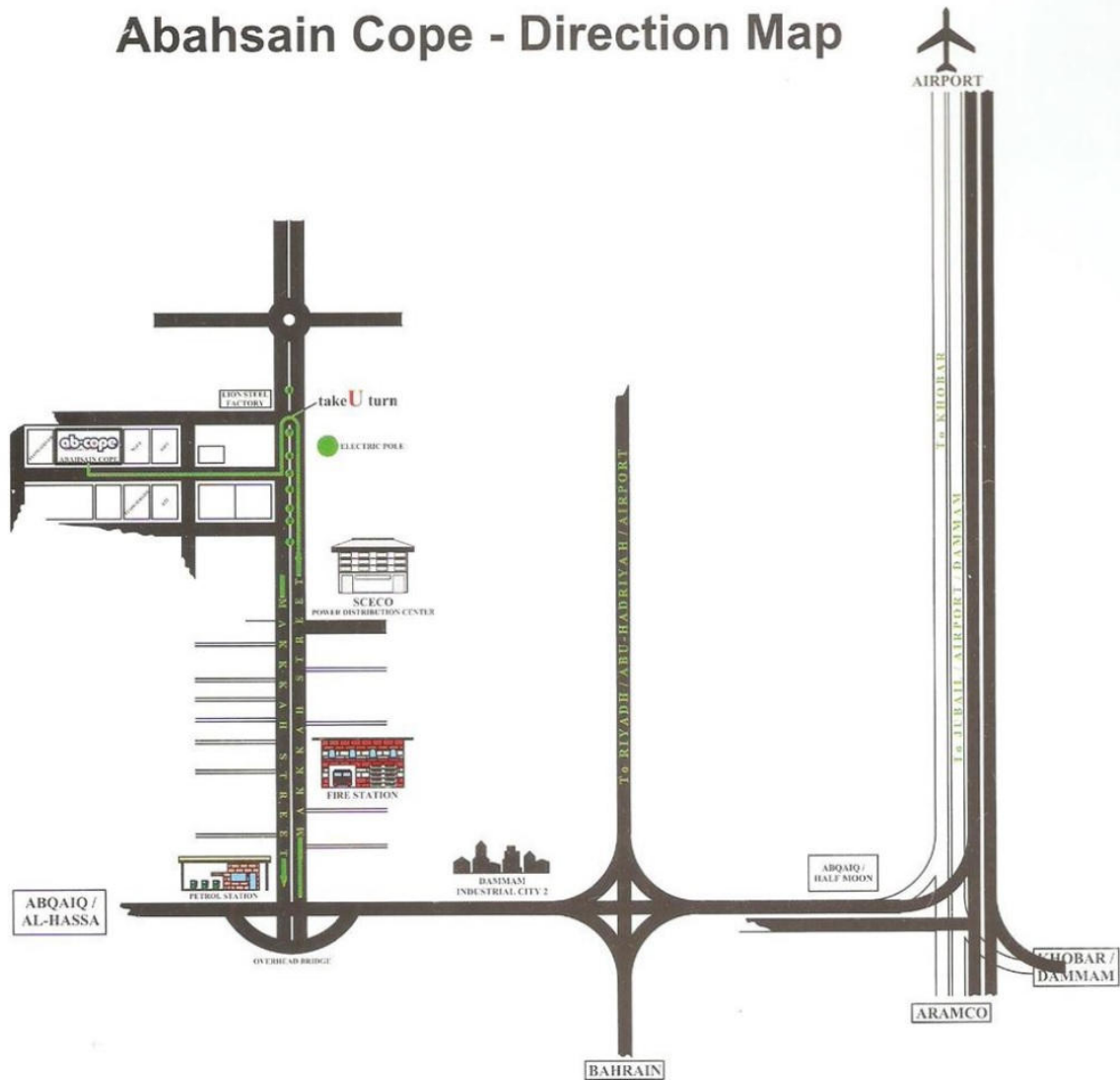

P.O. Box 38994 Dammam Industrial City II Kingdom of Saudi Arabia  
 Tel.: 013 808 6596, 808 6597, 808 6568, 808 6569,  
 808 6920, 808 6489, 808 7064  
 Fax: +966 13 857 1570  
 Email : [abcope@abahsain.net](mailto:abcope@abahsain.net)