



Abahsain- Cope Saudi Arabia Ltd.

P.O. 38994, Dhahran-Doha 31942, Saudi Arabia

Tel : +966-3-859 5912

Fax : +966-3-857 1570

Email: abcope@zajil.net

UNISTRUT

Support Solution

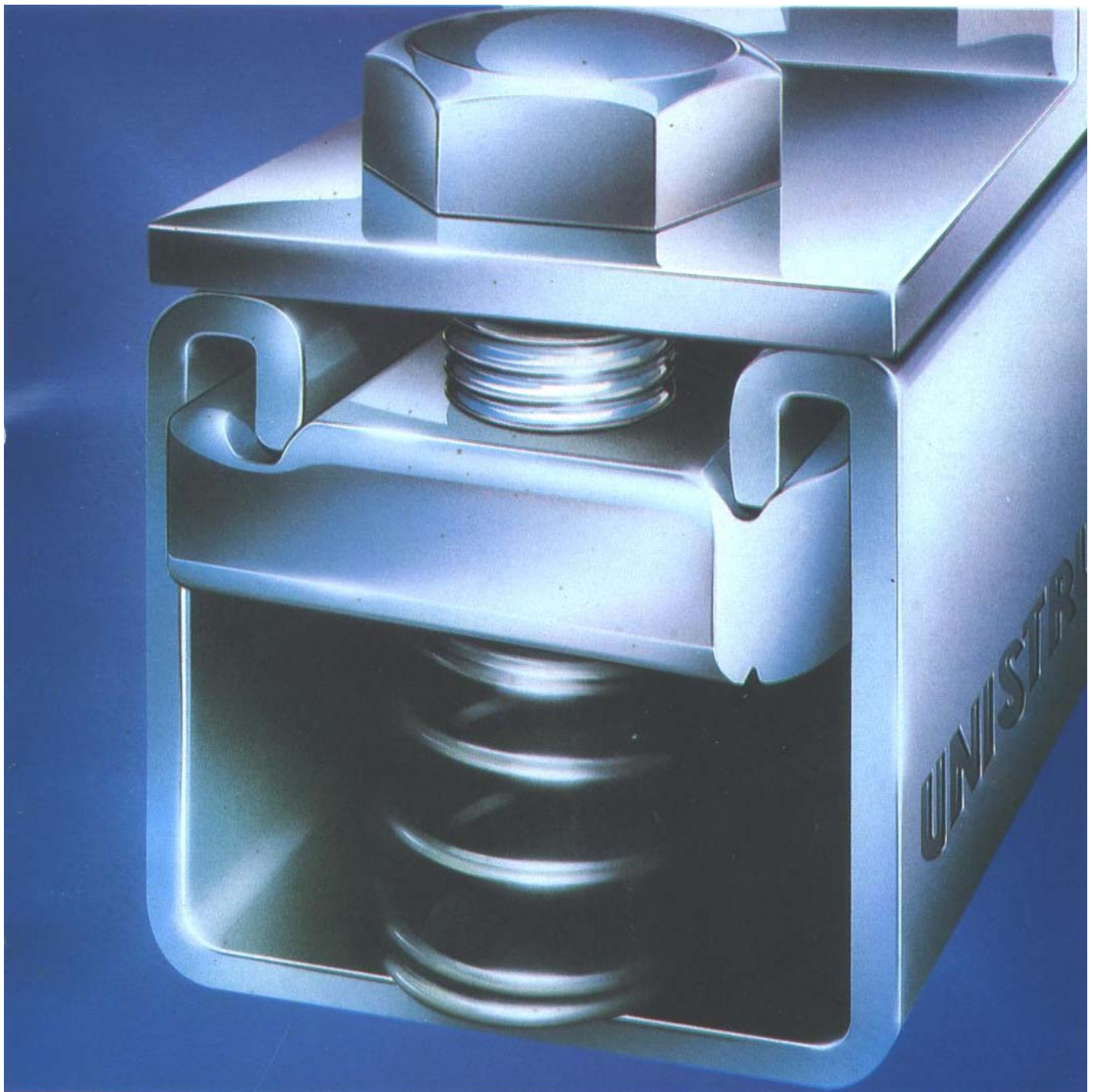



Contents

Introduction to Unistrut

- Unistrut Metal Framing System
- Materials & Finishes
- Conversion Factors
- Reference Tables & Guide Specification

Channels & Combinations

- P1000 – 12 Gauge
- P1100 – 14 Gauge
- P2000 – 16 Gauge
- P3000 – 12 Gauge
- P3300 – 12 Gauge
- P4000 – 16 Gauge
- P4100 – 14 Gauge
- P5000 – 12 Gauge
- P5500 – 12 Gauge
- Closure Strips
- Pierced Sections
- P9000 Series – 12 Gauge

Nuts, Bolts & Hardware

- Channel Nut Selection Chart
- Channel Nuts with Spring
- Channel Nuts Without Spring
- Hardware

Fittings & Channel Accessories

- Flat Plate Fittings
- 90 Degree Fittings
- Angled Fittings
- U & Z shaped Fittings
- Base Plate & Wing Fittings
- M5 / M6 Fittings
- Special Order Fittings
- Beam Clamps
- Cantilever Arms
- Tray Arms
- Fluorescent Lighting Supports & Fittings
- Channel Accessories

Pipe Supports & Fittings

- Copper Pipes
- Steel Pipes
- Beam Clamps, Pipe Clamps & Pipe Hangers
- Hydraulic Pipes
- Accessories

Structural Connections

- Concrete Inserts
- Short Concrete Inserts
- Universal Steel Connections
- Beam Clamps, Pipe Clamps & Pipe Hangers

Featuring The Unique Weldless Connection

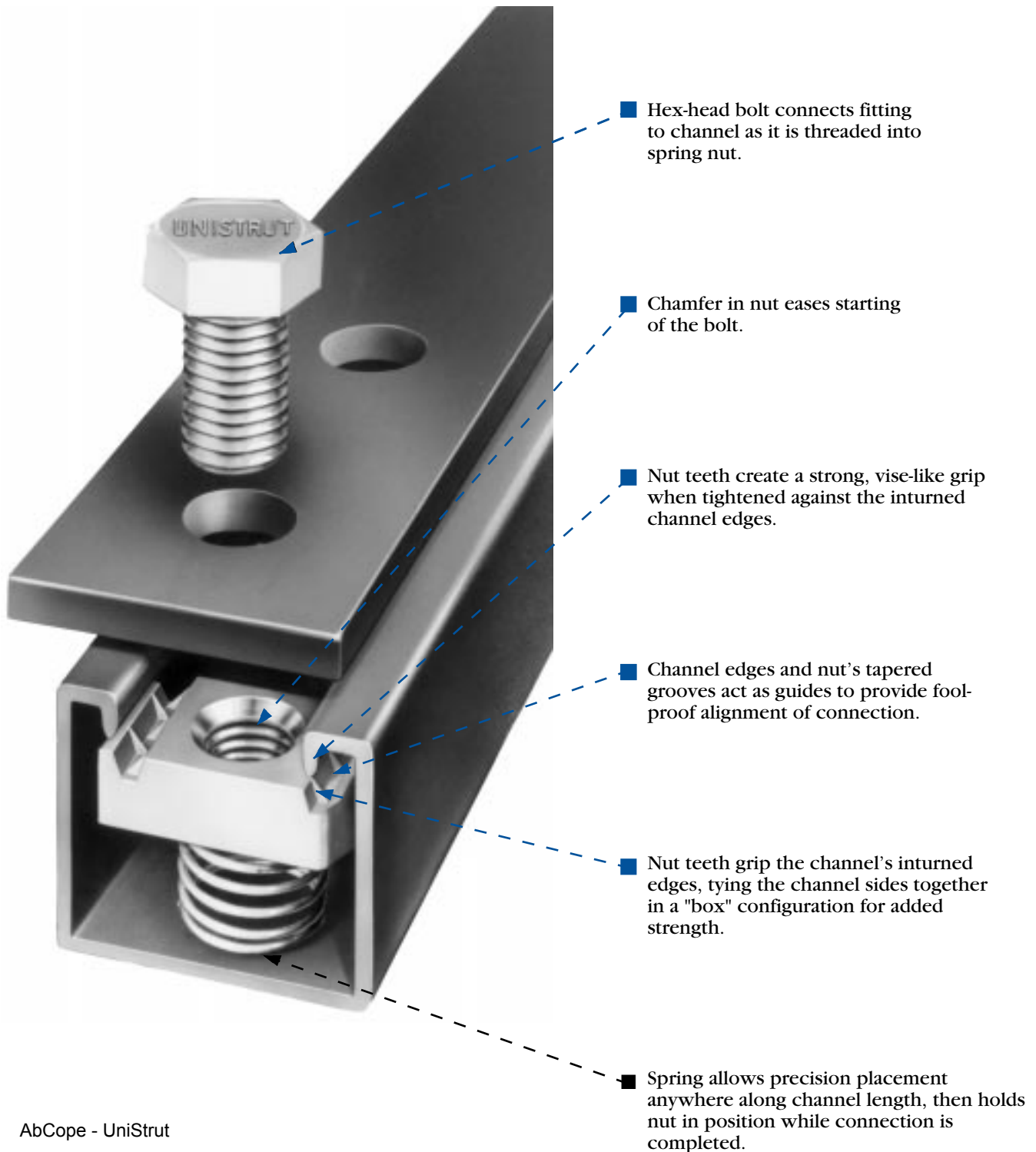

Strong, Fast, Economical and Adjustable

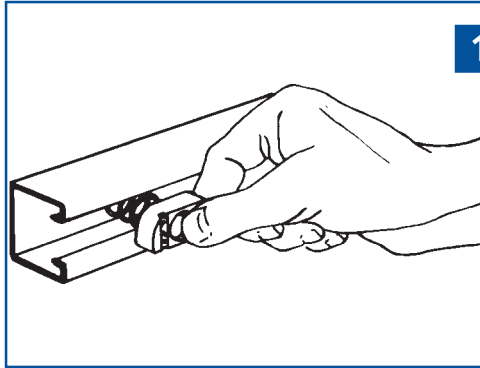

1 Insert the spring nut anywhere along the continuous slotted channel. The rounded nut ends permit easy insertion.

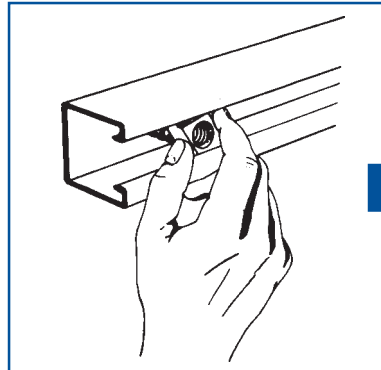

A 90° clockwise turn aligns the grooves in the nut with the inturned edges of the channel.

2 Fittings can be placed anywhere along the channel opening, permitting complete freedom of adjustment. The need for drilling holes is eliminated.

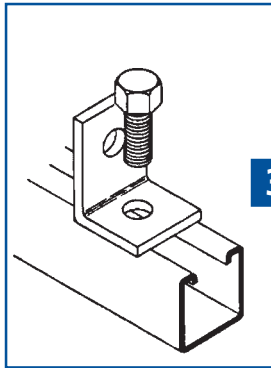

3 Insert bolt through fitting and into the spring nut. (See illustration 5 for end view showing nut in place)

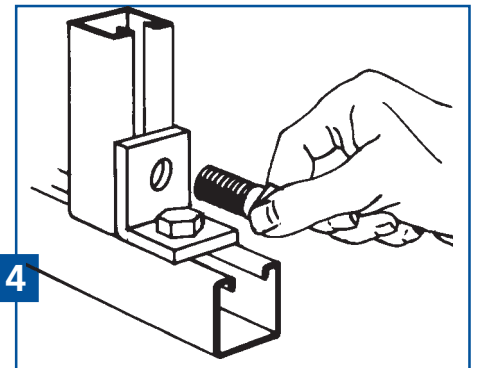

4

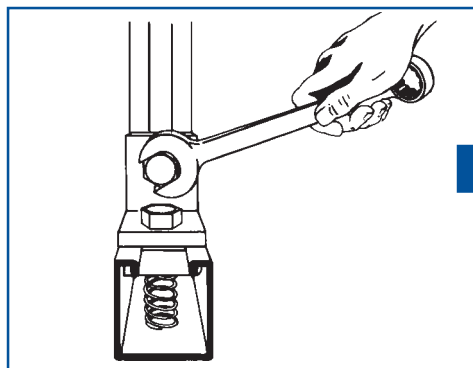

5 Tightening with a wrench locks the serrated teeth of the nut into the inturned edges of the channel, to complete a strong, vise-like connection.



Serving Design Professionals for Over 60 Years

Unistrut products have been helping to build a better world since 1924. Used extensively in nuclear, industrial and commercial construction markets for over 60 years, Unistrut Metal Framing has set the standard for product design, quality and performance. The initial Unistrut concept — a simple spring nut and bolt connecting a fitting to a continuous slotted channel — has evolved into a comprehensive engineered building and support system.

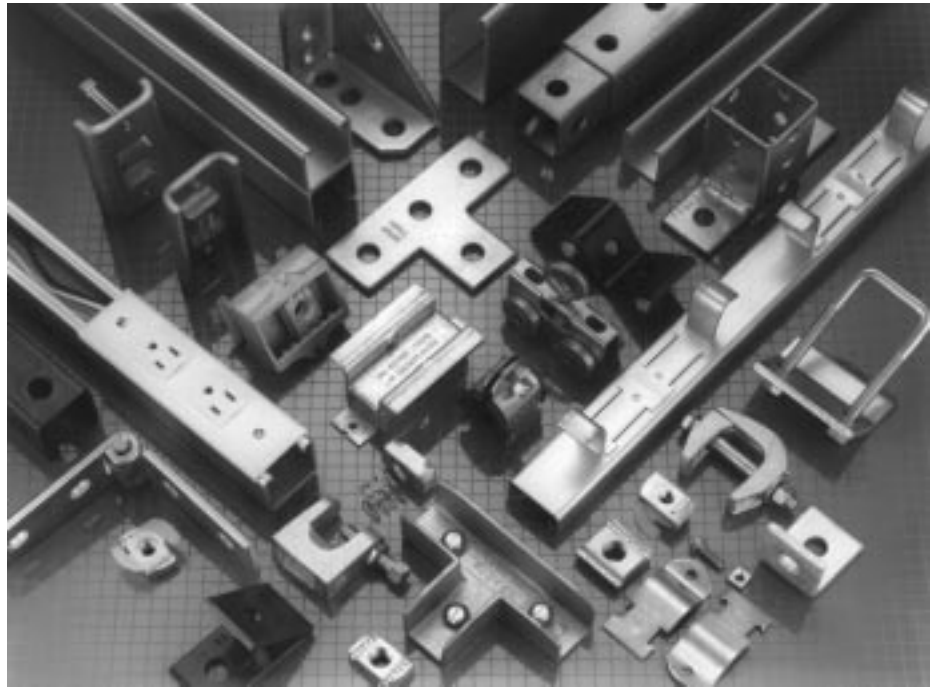

Unistrut — The Original Metal Framing System

There is only one Unistrut Metal Framing System. It incorporates the innovative product improvements that our research and

development group has created to give you the most complete and flexible support system available. Backed by our worldwide network of engineering and distribution centers, Unistrut provides customers with total-resource capability.

principal cities in North America to serve you quickly and directly. Many Service Centers are equipped to design and supply drawings for any type of metal framing application and also offer fabrication and installation services.

Over 50 Unistrut Service Centers — stocking standard Unistrut components — are located in

This catalog is a comprehensive presentation of Unistrut Metal Framing components plus technical data required by design, specification and construction professionals.

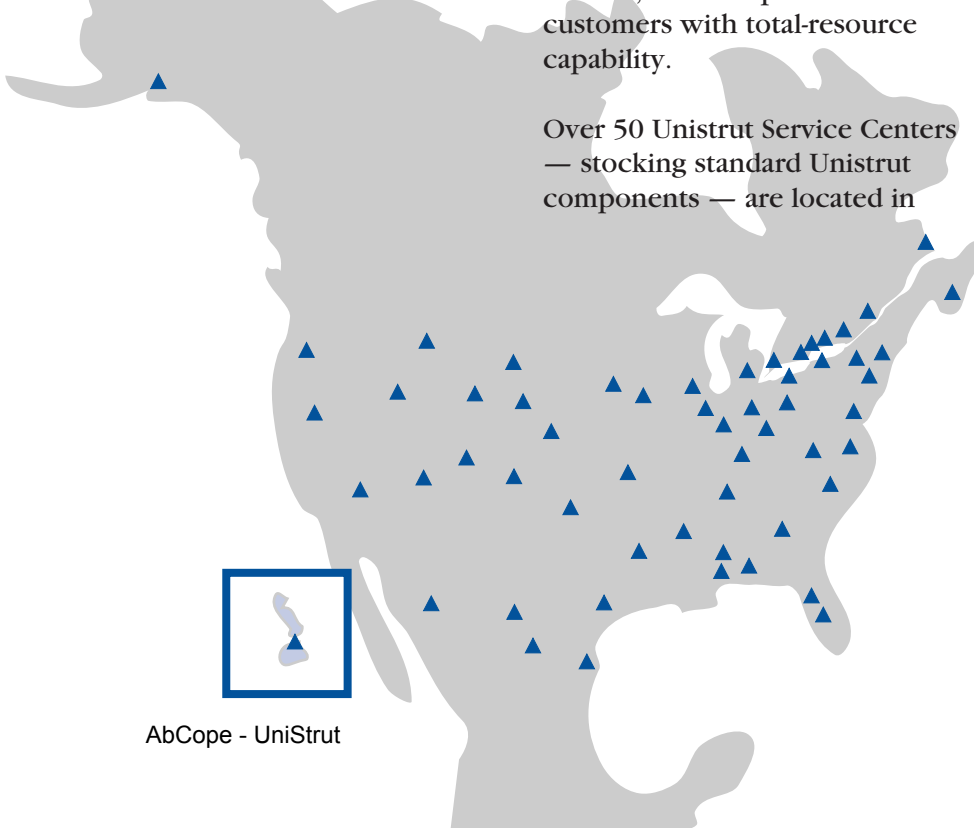



The Most Complete Metal Framing System — Offering Three Channel-Width Options

Adjustability, demountability and reusability are engineered into each of the three UniStrut channel series. Each series offers channels of varying depth and gage plus a complete line of fittings and accessories.

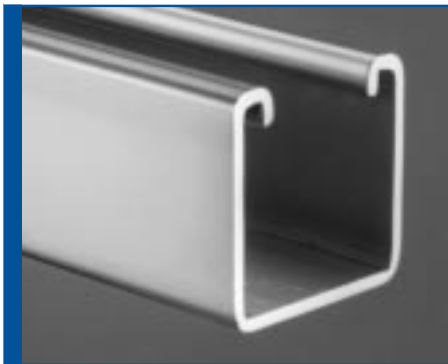

1 5/8" width Series Channel begins on page 20.

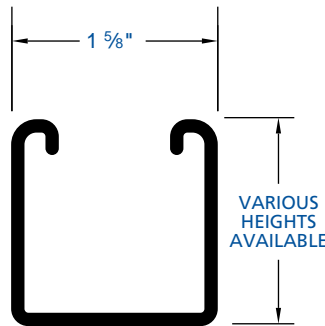

1 5/8" (41mm) width

Designed to carry the heaviest loads and provide the widest variety of applications, the 1 5/8" series has become the accepted standard for use in mechanical, electrical and general construction applications where supports and attachments must meet the highest strength requirements.

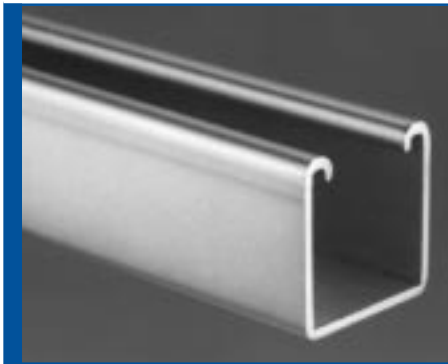

1 1/4" width Series Channel begins on page 180.

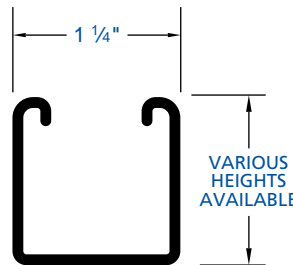

1 1/4" (32mm) width

A framing system designed for medium loads, the 1 1/4" series is especially suitable for use in the OEM, commercial and display markets. It maintains a lightness in scale and a clean line that makes it aesthetically pleasing as well as functional.

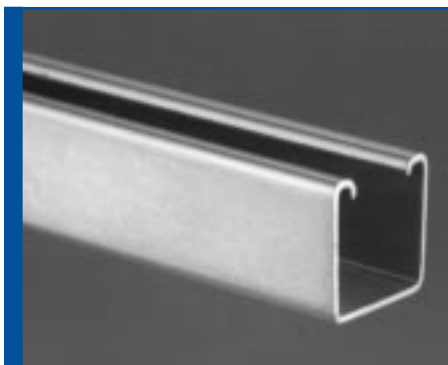

1 3/16" width Series Channel begins on page 198.

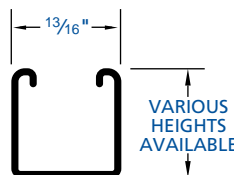

1 3/16" (21mm) width

A unique half-size reduction of the 1 5/8" channel-width series, this smaller channel size can be used to carry light loads economically in applications such as instrumentation, retail displays and light-duty laboratory supports. It also provides the flexibility found in all UniStrut framing systems.



Framing Members

Unistrut channels and continuous inserts are accurately and carefully cold-formed to size from low carbon strip steel. One side of the channel has a continuous slot with inturned edges. Secure attachments may be made to the framing member with the use of hardened, toothed, slotted nuts which engage the inturned edges.

Raw steel shall conform to the following ASTM specifications.

GAGE	FINISH	ASTM NO.
12	GR & HG PG	A570 GR 33 A653 GR 33
14	GR & HG PG	A570 GR 33 A653 GR 33
16	GR & HG PG	A366 A653 GR 33
19	GR	A366

Fittings

Unistrut fittings, unless noted otherwise, are punch-press made from hot rolled, pickled and oiled steel plates, strip or coil, and conform to ASTM specifications A575, A576, A635 or A36. The fitting steel also meets the physical requirement of ASTM A570 GR 33. The pickling of the steel produces a smooth surface free from scale.

Nuts and Bolts

Unistrut nuts are made from steel bars. After all machining operations are complete, they are thoroughly case hardened. Nuts are rectangular with ends shaped to permit a quarter turn clockwise in the framing member

after insertion through the slotted opening in the channel. Two toothed grooves in the top of the nut engage the inturned edges of the channel and, after bolting operations are completed, will prevent any movement of the bolt and nut within the framing member. All bolts and nuts have Unified coarse screw threads. The standard framing nut is 1/2" and conforms to ASTM Specification A576 GR 1015 (material only). Screws conform to SAE J429 GR 2 (also meets and exceeds ASTM A307).

Finishes

PERMA-GREEN® II (GR)

Channel and parts are carefully cleaned and phosphated. Immediately after phosphating, a uniform coat of a highly effective rust-inhibiting acrylic enamel paint is applied by electro-deposition and thoroughly baked. Color is Perma-Green per Federal Standard 595a color number 14109 (dark limit V-). The resulting finish will withstand 400 hours of salt spray when tested in accordance with ASTM designation B-117.

ELECTRO-GALVANIZED (EG)

Parts, screws and nuts are coated with zinc electrolytically to commercial standards (ASTM - B633 Type III SC1).

PLAIN (PL)

Plain finish designation means that the channel retains the oiled surface applied to the raw steel during the rolling process. The fittings have the original oiled surface of the bar-stock material.

PRE-GALVANIZED (PG)

Material (steel strip) is coated with zinc by hot-dip process prior to roll-forming or press operations. The zinc coating weight is G90 conforming to ASTM Specification A653 GR 33.

HOT-DIPPED GALVANIZED (HG)

Material is coated with zinc after being roll-formed or after all manufacturing operations are completed, conforming to ASTM specification No. A123 or A153.

SPECIAL COATING

When specific applications require other than standard available finishes, special finishes can be supplied per customer requirements.

WEIGHTS AND DIMENSIONS

Weights given for all materials are approximate shipping weights. All dimensions subject to commercial tolerance within published specifications.

WE RESERVE THE RIGHT TO MAKE SPECIFICATION CHANGES WITHOUT NOTICE .

WHILE EVERY EFFORT HAS BEEN MADE TO ASSURE THE ACCURACY OF INFORMATION CONTAINED IN THIS CATALOG AT THE TIME OF PUBLICATION, WE CANNOT ACCEPT RESPONSIBILITY FOR INACCURACIES RESULTING FROM UNDETECTED ERRORS OR OMISSIONS.

THE BLUE COLOR USED ON UNISTRUT COMPONENTS ILLUSTRATED IN THIS CATALOG IS FOR GRAPHIC ENHANCEMENT ONLY, AND DOES NOT REPRESENT ACTUAL PRODUCT COLOR.



Perma-Green® II

The performance of Unistrut's Perma-Green II far exceeds that of conventional finishes. And compared to competitive "high-performance" coatings, Perma-Green II provides superior resistance to chalking, checking and fading and is far less vulnerable to common acidic atmospheres, solvents and alkalis. Just as important, Perma-Green II is the result of an environmentally neutral process that virtually eliminates the toxic metals commonly found in competitive paint-based finishes.

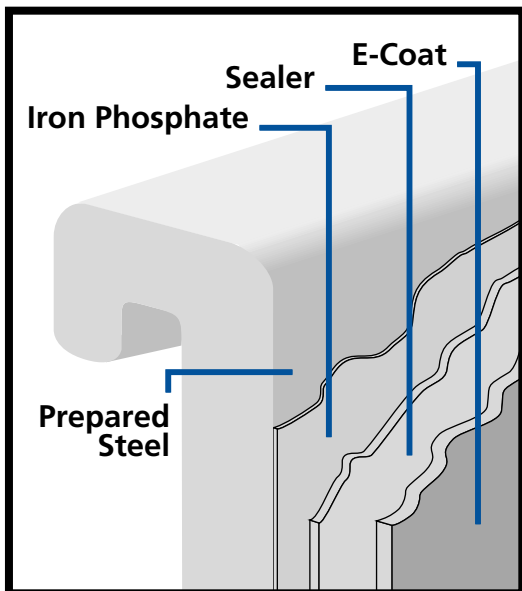
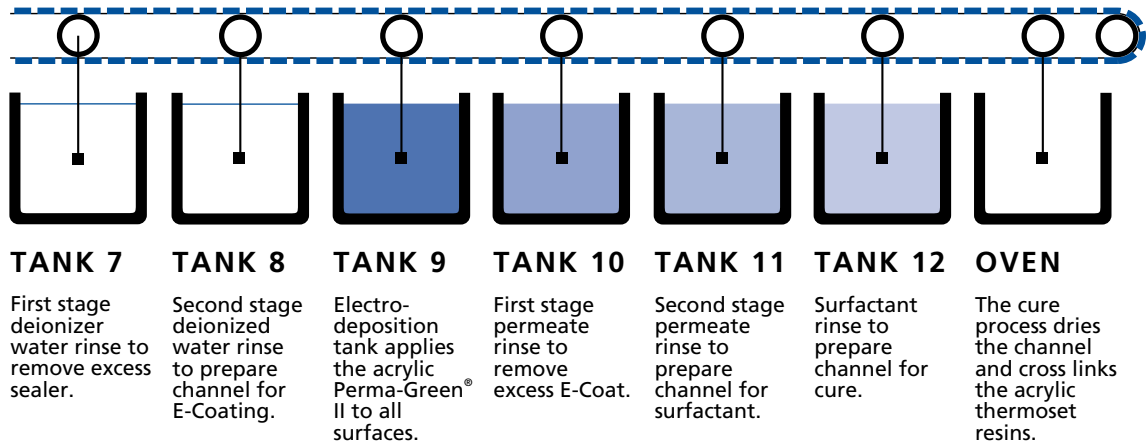
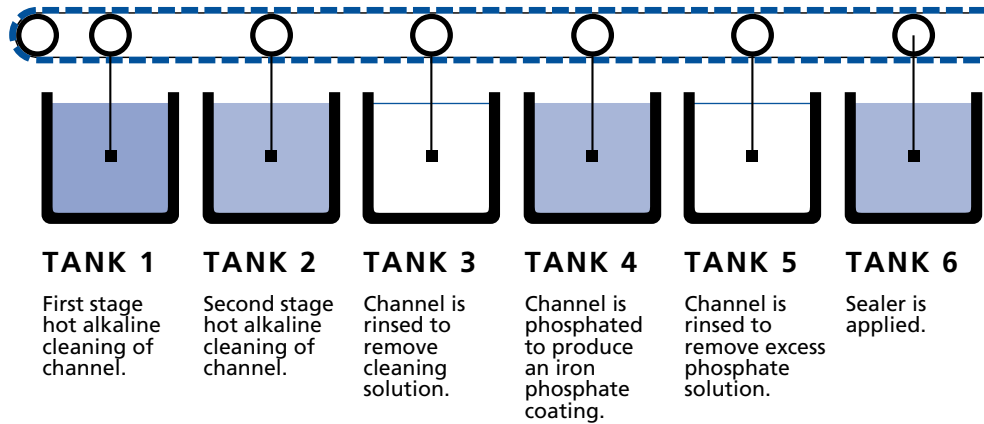

Unistrut Perma-Green II is a factory applied, electro-deposition acrylic coating with superior rust protection and fade-resistance. The acrylic coating is a proprietary formulation and is essentially "heavy-metal" free. The electrodeposition coating process provides a smooth, hard, durable surface which is completely cured. This inhibits introduction of airborne contaminants which can adversely affect sensitive manufacturing environments.

Before the electrodeposition acrylic coating is applied, Unistrut channel and fittings are

thoroughly cleaned and coated with an iron phosphate conversion coating. Unistrut's unique, custom-designed "prep" process consists of eight separate steps, the most thorough in the industry. The cleaning, phosphating and electrodeposition coating processes are continuous and, unlike "batch" processing, result in a uniform quality coating.

Production samples are tested on a continuous basis for corrosion resistance. Unistrut Perma-Green II exceeds 400 hours salt spray (1/8" creep from scribe) when tested to ASTM B117. Unscrubbed samples exceed 600 hours salt spray.



PERMA-GREEN® II TECHNICAL DATA

STEEL SUBSTRATE PREPARATION

Eight stage continuous cleaning, phosphate process.

Substrate after “prep”: sealed iron phosphate conversion coating.

COATING

Thermoset acrylic

Color: Green Federal STD. 595A, Color No. 14109, Dark Limit V-

Hardness: 2H.

Coating Process: Anodic Electrodeposition.

PERFORMANCE

Salt Spray:

Scribed: exceeds 400 hours per ASTM B117.

Unscribed: exceeds 600 hours per ASTM B117.

Chalk: nominal at 1,000 hours per weatherometer G-23 test.

Checking: None at 1,000 hours per weatherometer G-23 test.

Fade: Less than 50% compared to standard epoxy E.C. coatings.

ENVIRONMENTAL ISSUES

Formulated as a “heavy metal”-free coating (trace elements only).

Outgassing in service: essentially none at 350°F for 24 hours.

Zinc Coating

Unistrut products are available in three types of zinc coatings: electroplated, pregalvanized and hot dip galvanized.

Zinc coatings offer two types of protection:

1. Barrier: The zinc coating protects the steel substrate from direct contact with the environment,
2. Sacrificial: The zinc coating will protect scratches, cut edges, etc. through an anodic sacrificial process.

The service life of zinc coating is directly related to the zinc coating thickness. As shown in graph, when the zinc coating is double, the service life is double under most conditions.

Electroplated Zinc– ASTM B633 Type III SC1

In the electroplating process, the part to be zinc coated is immersed in a solution of zinc ions. An electric current causes the zinc to be deposited on the part.

Zinc plated parts typically have a zinc coating of .2 to .5 MIL and are recommended for dry indoor use.

Pregalvanized Zinc- ASTM A525

Pregalvanized steel is zinc coated by a hot dip process. Steel strip from a coil is fed through a continuous zinc coater which cleans, fluxes and coats the steel with molten zinc. After cooling, the steel is recoiled.

The pregalvanized zinc coating conforms to a G-90 thickness designation per ASTM A653. The zinc thickness is .75 MIL or .45 oz./sq. ft. of surface area.

This coating is offered on Unistrut channel and tubing and is a well-proven, time-tested performer for indoor and outdoor applications. For severe corrosion applications, hot dip galvanizing, as described below, is a good alternative.

LIFE OF PROTECTION VS. THICKNESS OF ZINC AND TYPE OF ATMOSPHERE

* Service Life is defined as the time to 5% rusting of the steel surface

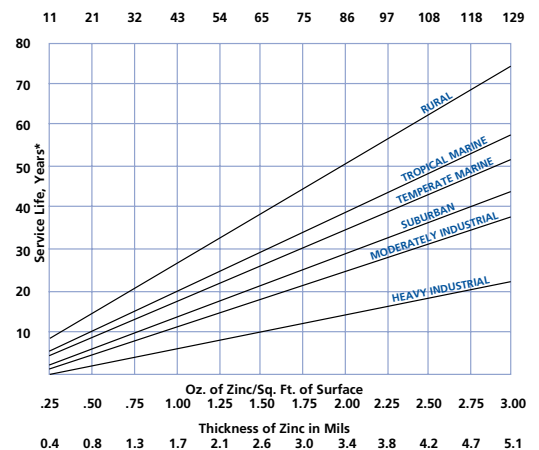

Hot Dip Galvanized– ASTM A123 OR A153

In hot dip galvanizing, the finished part is immersed in a bath of molten zinc. This method results in complete zinc coverage and a thicker coating than pregalvanized or plated zinc.

The zinc coating is typically 2.6 MIL or 1.5 oz./sq. ft. of surface area.

This is the coating of choice for applications where severe corrosion is a design factor.



To Convert From	To	Multiply By	To Convert From	Multiply To	By
Length					
Inch [in]	Millimeter [mm]	25.400 000	Millimeter [mm]	Inch [in]	0.039 370
Foot [ft]	Meter [m]	0.304 800	Meter [m]	Foot [ft]	3.280 840
Yard [yd]	Meter [m]	0.914 400	Meter [m]	Yard [yd]	1.093 613
Mile (U.S. Statute) [mi]	Kilometer [km]	1.609 347	Kilometer [km]	Mile (U.S. Statute) [mi]	0.621 370
Area					
Square Inch [in ²]	Square Millimeter [mm ²]	645.16	Square Millimeter [mm ²]	Square Inch [in ²]	0.001550
Square Foot [ft ²]	Square Meter [m ²]	0.092 903	Square Meter [m ²]	Square Foot [ft ²]	10.763 915
Square Yard [yd ²]	Square Meter [m ²]	0.836 127	Square Meter [m ²]	Square Yard [yd ²]	1.195 991
Square Mile [mi ²] (U.S. Statute)	Square Kilometer [km ²]	2.589 998	Square Kilometer [km ²]	Square Mile [mi ²] (U.S. Statute)	0.386 101
Acre	Square Meter [m ²]	4046.873	Square Meter [m ²]	Acre	0.000 247
Acre	Hectare	0.404 687	Hectare	Acre	2.471 046
Volume					
Cubic Inch [in ³]	Cubic Millimeter [mm ³]	16387.06	Cubic Millimeter [mm ³]	Cubic Inch [in ³]	0.000061
Cubic Foot [ft ³]	Cubic Meter [m ³]	0.028 317	Cubic Meter [m ³]	Cubic Foot [ft ³]	35.314 662
Cubic Yard [yd ³]	Cubic Meter [m ³]	0.764 555	Cubic Meter [m ³]	Cubic Yard [yd ³]	1.307 950
Gallon (U.S. Liquid) [gal]	Litre [l]	3.785 412	Litre [l]	Gallon (U.S. Liquid) [gal]	0.264 172
Quart (U.S. Liquid) [qt]	Litre [l]	0.946 353	Litre [l]	Quart (U.S. Liquid) [qt]	1.056 688
Mass					
Ounce (Avoirdupois) [oz]	Gram [g]	28.349 520	Gram [g]	Ounce (Avoirdupois) [oz]	0.035 274
Pound (Avoirdupois) [lb]	Kilogram [kg]	0.453 592	Kilogram [kg]	Pound (Avoirdupois) [lb]	2.204 624
Short Ton	Kilogram [kg]	907.185	Kilogram [kg]	Short Ton	0.00110
Force					
Ounce-Force	Newton [N]	0.278 014	Newton [N]	Ounce-Force	3.596 941
Pound-Force [lbf]	Newton [N]	4.448 222	Newton [N]	Pound-Force [lbf]	0.224 809
Bending Moment					
Pound-Force-Inch [lbf-in]	Newton-Meter [N-m]	0.112 985	Newton-Meter [N-m]	Pound-Force-Inch [lbf-in]	8.850 732
Pound-Force-Foot [lbf-ft]	Newton-Meter [N-m]	1.355 818	Newton-Meter [N-m]	Pound-Force-Foot [lbf-ft]	0.737 562
Pressure, Stress					
Pound-Force per Square Inch [lbf/in ²]	Kilopascal [kPa]	6.894 757	Kilopascal [kPa]	Pound-Force per Square Inch [lbf/in ²]	0.145 038
Foot of Water (39.2 F)	Kilopascal [kPa]	2.988 980	Kilopascal [kPa]	Foot of Water (39.2 F)	0.334 562
Inch of Mercury (32 F)	Kilopascal [kPa]	3.386 380	Kilopascal [kPa]	Inch of Mercury (32 F)	0.295 301
Energy, Work, Heat					
Foot-Pound-Force [ft-lbf]	Joule [J]	1.355 818	Joule [J]	Foot-Pound-Force [ft-lbf]	0.737 562
British Thermal Unit [Btu]	Joule [J]	1055.056	Joule [J]	British Thermal Unit [Btu]	0.000948
Calorie [cal]	Joule [J]	4.186 800	Joule [J]	Calorie [cal]	0.238 846
Kilowatt Hour [kW-h]	Joule [J]	3600000	Joule [J]	Kilowatt Hour [kW-h]	2.78 ⁻⁷
Power					
Foot-Pound-Force /Second [ft-lbs/s]	Watt [W]	1.355 818	Watt [W]	Foot-Pound-Force /Second [ft-lbs/s]	0.737 562
British Thermal Unit /Hour [Btu/h]	Watt [W]	0.293 071	Watt [W]	British Thermal Unit /Hour [Btu/h]	3.412 142
Horsepower (550 Ft. Lbf/s) [hp]	Kilowatt [kW]	0.745 700	Kilowatt [kW]	Horsepower (550 Ft. Lbf/s) [hp]	1.341 022
Angle					
Degree	Radian [rad]	0.017 453	Radian [rad]	Degree	57.295 788
Temperature					
Degree Fahrenheit [F]	Degree Celsius [C]	(F° -32)/1.8	Degree Celsius [C]	Degree Fahrenheit [F]	1.8xC°+32

CANTILEVER BEAMS

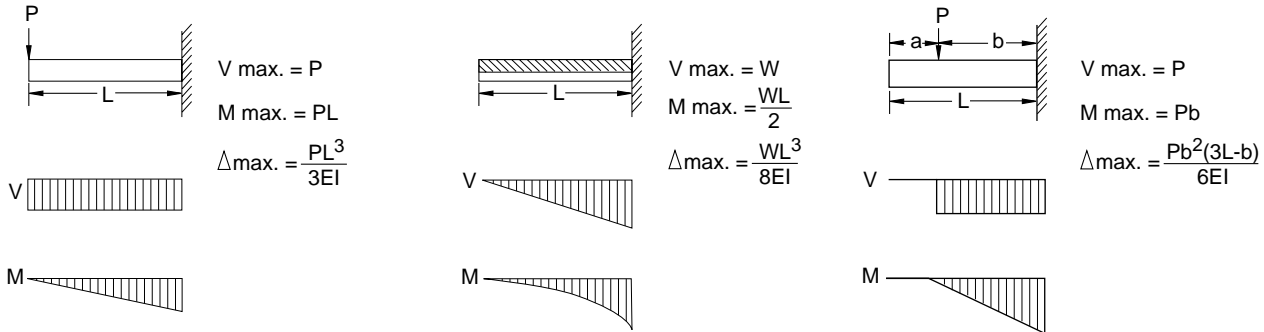

SIMPLE BEAMS

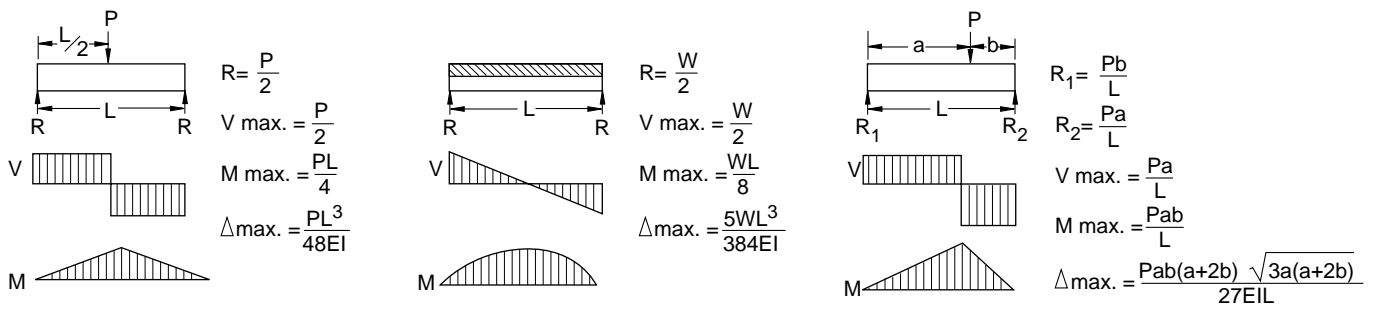

BEAMS FIXED AT ONE END, SUPPORTED AT OTHER

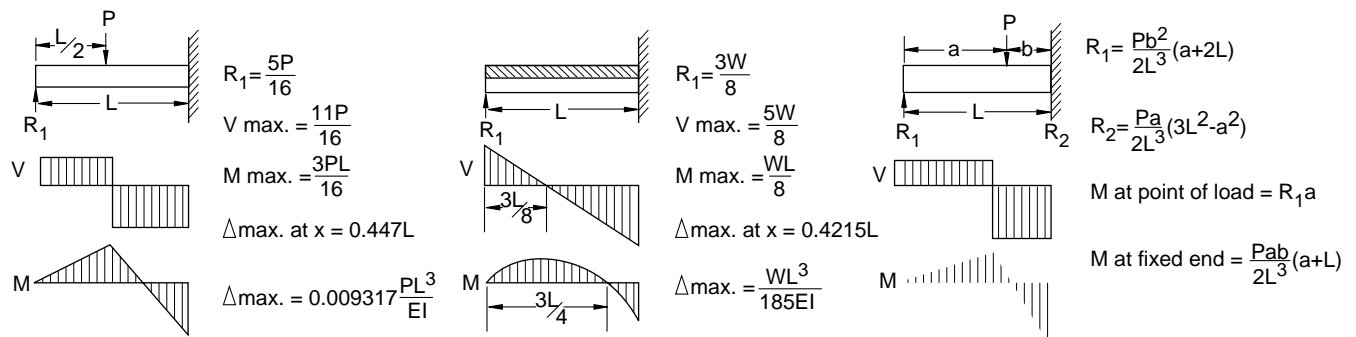

BEAMS FIXED AT BOTH ENDS

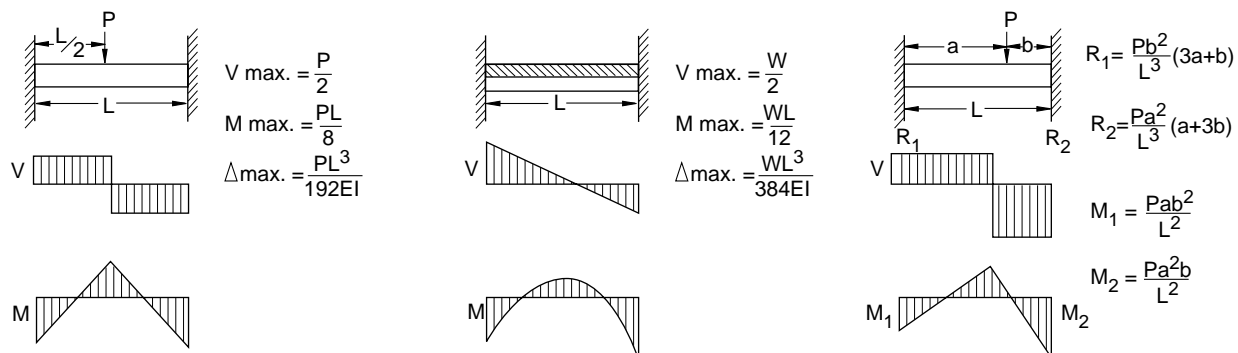

R – Reaction
M – Moment
P – Concentrated Load



W – Total Uniform Load
V – Shear
L – Length

Δ – Deflection
E – Modulus of Elasticity
I – Moment of Inertia

CONVERSION FACTORS FOR BEAMS WITH VARIOUS STATIC LOADING CONDITIONS

All Beam Load tables are for single-span (simple) beams supported at the ends. These can be used in the majority of the cases.

There are times when it is necessary to know what happens with other loading and support conditions. Some common arrangements are shown below. Simply multiply the values from the Beam Load tables by factors given below

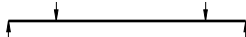
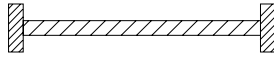
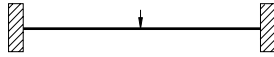
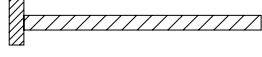
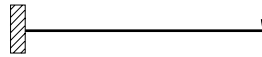
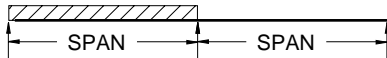
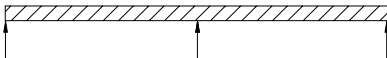
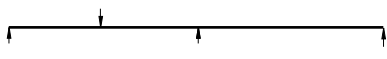
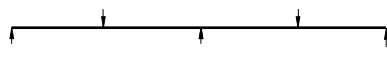
LOAD AND SUPPORT CONDITION	LOAD FACTOR	DEFLECTION FACTOR
1. Simple Beam, Uniform Load 	1.00	1.00
2. Simple Beam, Concentrated Load at Center 	.50	.80
3. Simple Beam, Two Equal Concentrated Loads at 1/4 pts 	1.00	1.10
4. Beam Fixed at Both Ends, Uniform Load 	1.50	.30
5. Beam Fixed at Both Ends, Concentrated Load at Center 	1.00	.40
6. Cantilever Beam, Uniform Load 	.25	2.40
7. Cantilever Beam, Concentrated Load at End 	.12	3.20
8. Continuous Beam, Two Equal Spans, Uniform Load on One Span 	1.30	.92
9. Continuous Beam, Two Equal Spans, Uniform Load on Both Ends 	1.00	.42
10. Continuous Beam, Two Equal Spans, Concentrated Load at Center of One Span 	.62	.71
11. Continuous Beam, Two Equal Spans, Concentrated Load at Center of Each Span 	.67	.48

**EXAMPLE I
PROBLEM:**

Determine load and deflection of a P 1000 beam continuous over one support and loaded uniformly on one span.

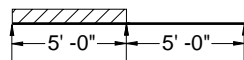

SOLUTION:

- A. From load table for P1000 on page 24 load for a 5'-0" span is 680# and deflection is .35".
- B. Multiply by factors from Table above.
Load = 680# x 1.30 = 884#
Deflection = .35" x .92 = .32"

**EXAMPLE II
PROBLEM:**

Determine load and deflection of a P 5500 cantilever beam with a concentrated load on the end.



SOLUTION:

- A. From load table P5500 on page 57 load for a 3'-0" span is 2190# and deflection is .09".
- B. Multiply by factors from Table above.
Load = 2190# x .12 = 263#
Deflection = .09" x 3.20 = .29"

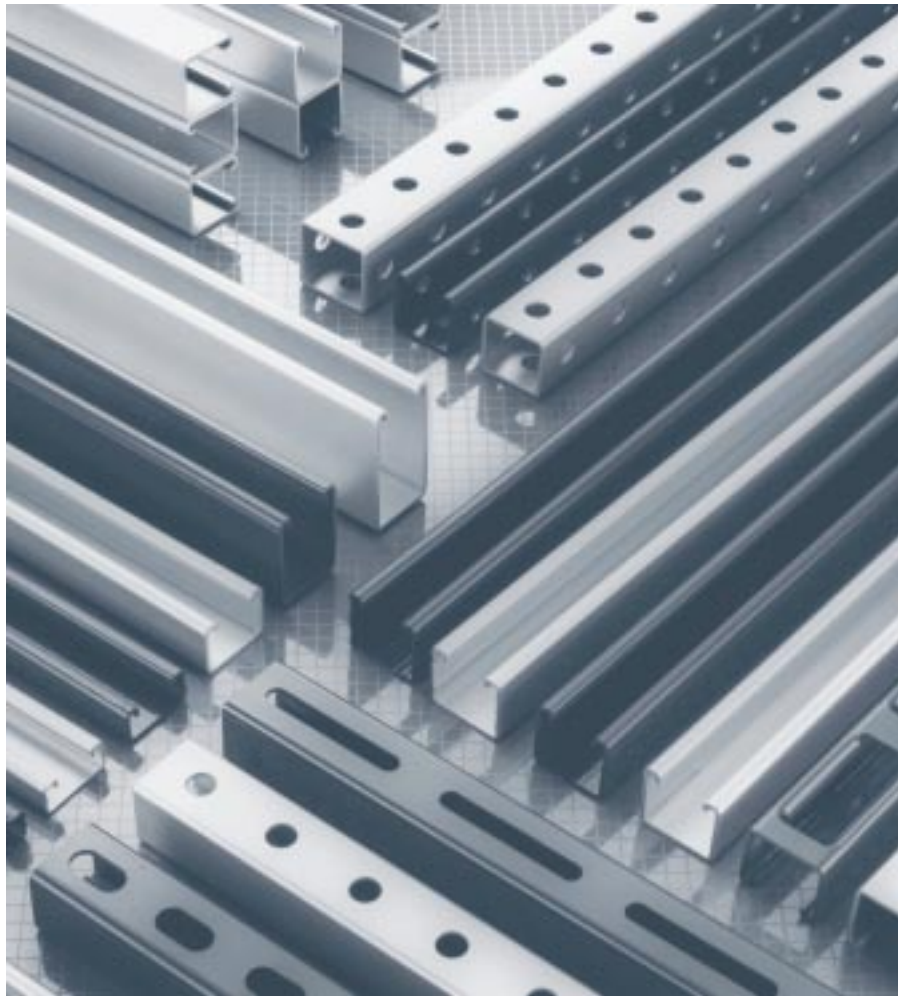

MATERIAL

Unistrut channels are accurately and carefully cold formed to size from low-carbon strip steel.

Spot-welded combination members are welded 3" (maximum) on center.

STEEL: PLAIN

12 Ga. (2.5 mm), 14 Ga.(1.9 mm)
ASTM A570 GR 33
16 Ga. (1.5 mm) ASTM A366

STEEL: PRE-GALVANIZED

12 Ga. (2.7 mm), 14 Ga. (1.9 mm)
and 16 Ga. (1.5mm) ASTM A653
GR 33

For other materials, see Special Metals and Fiberglass section.

FINISHES

All channels are available in: Perma Green II (GR), pre-galvanized (PG), conforming to ASTM A653; Hot-dipped galvanized (HG), conforming to ASTM A123 or A153; and plain (PL).

STANDARD LENGTHS

Standard lengths are 10 feet (3.05m) and 20 feet (6.10m). Tolerances are + $\frac{1}{8}$ " (3.2 mm) to + $\frac{1}{2}$ " (12.7 mm) to allow for cutting. Special lengths are available for a small cutting charge with a tolerance of $\pm\frac{1}{8}$ " (3.2mm).

CURVED CHANNEL

Many Unistrut $1\frac{5}{8}$ " (41mm) channel sections are available as curved pieces in both single and combination styles. Contact your local Unistrut Service Center or Unistrut Corporation for ordering information.

DIMENSIONS

Imperial dimensions are illustrated in inches. Metric dimensions are shown in millimeters and rounded to one decimal place.

LOAD DATA

All beam and column load data pertains to carbon steel and stainless steel channels. Load tables and charts are constructed to be in accordance with the SPECIFICATION FOR THE DESIGN OF COLD-FORMED STEEL STRUCTURAL MEMBERS AUGUST 19, 1986 EDITION with DECEMBER 11, 1989 ADDENDUM published by the AMERICAN IRON AND STEEL INSTITUTE.



P1000 SERIES

12 GA.
page 23



P1000

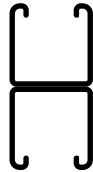

P1001

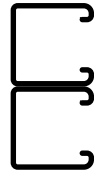

P1001A

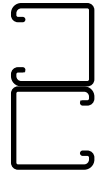

P1001B

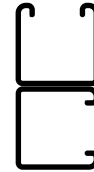

P1001C

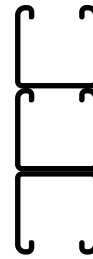

P1001 3



P1001 A3



P1001 B3

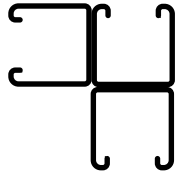

P1001 C3

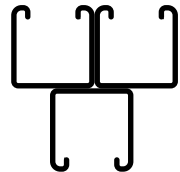

P1001 D3

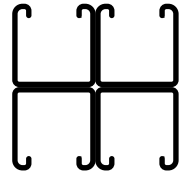

P1001 C41

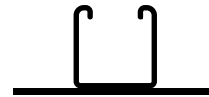

P1003



P1004A

P1100 SERIES

14 GA.
page 32



P1100

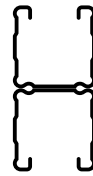

P1101

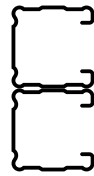

P1101A

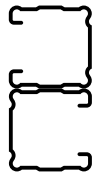

P1101B



P1101C

P3000 SERIES

12 GA.
page 40



P3000



P3001

P2000 SERIES

16 GA.
page 36



P2000



P2001

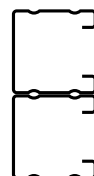

P2001A

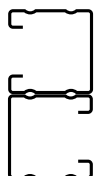

P2001B



P2001C

P3300 SERIES

12 GA.
page 43



P3300



P3301

P4000 SERIES

16 GA.
page 46



P4000



P4001



P4003



P4004

P4100 SERIES

14 GA.
page 50



P4100

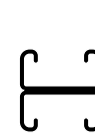

P4101

P5000 SERIES

12 GA.
page 53



P5000



P5001

P5500 SERIES

12 GA.
page 56



P5500

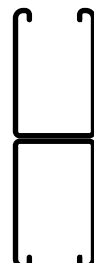

P5501

P9000 SERIES

12 GA.
page 62



P9000





P9200

See page 180 for 1-1/4" width channels and combinations and page 198 for 13/16" channels and combinations.

Combinations not shown in catalog are available on special order. Consult factory for details.

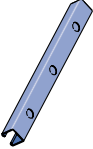
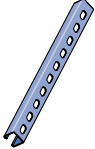
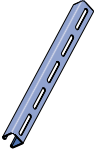
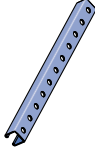

CHANNEL SELECTION CHART

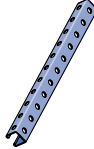
Channel	Channel Dimensions				Material & Thickness			Hole Pattern Styles					
	Width		Height		Steel	Stain-less Steel	Alum.	KO	T	SL	HS	DS	H3
	In	mm	In	mm									
P1000	1 $\frac{1}{8}$	41	1 $\frac{5}{8}$	41	12 ga	12 ga	.109	■	■	■	■	■*	■*
P1100	1 $\frac{1}{8}$	41	1 $\frac{5}{8}$	41	14 ga	14 ga	—	■	■	■	■		
P2000	1 $\frac{1}{8}$	41	1 $\frac{5}{8}$	41	16 ga	—	—	■	■	■	■		
P3000	1 $\frac{1}{8}$	41	1 $\frac{3}{8}$	35	12 ga	—	—	■	■	■	■		
P3300	1 $\frac{1}{8}$	41	$\frac{7}{8}$	22	12 ga	12 ga	—		■	■	■		
P4000	1 $\frac{1}{8}$	41	1 $\frac{3}{16}$	21	16 ga	16 ga	.078		■	■	■		
P4100	1 $\frac{1}{8}$	41	1 $\frac{3}{16}$	21	14 ga	—	—		■	■	■		
P5000	1 $\frac{1}{8}$	41	3 $\frac{1}{4}$	83	12 ga	—	—	■	■	■	■		
P5500	1 $\frac{1}{8}$	41	2 $\frac{7}{16}$	62	12 ga	—	.109	■	■	■	■		

* This reference chart reflects the available channels and hole patterns manufactured by Unistrut Corporation.

* Stainless steel sections are also available on special order in "T," "SL" and "HS" hole pattern.

* Metric equivalent for material thickness: 12 ga. (2.5 mm); 14 ga. (1.9 mm); and 16 ga. (1.5 mm).

* Not available in aluminum.

CHANNELS & COMBINATIONS IN DESCENDING ORDER OF STRENGTH

Channel	S in ³	I in ⁴	Area in ²	Weight Lbs/Ft
P5001	1.716*	5.578*	1.794	6.10
P1004 A	1.673	4.079	1.978	6.70
P5501	1.153	2.811	1.453	4.94
P1001 C41	1.145	1.860	2.223	7.60
P5000	.628	1.099	.897	3.05
P1001	.572	.930	1.112	3.80
P1101	.456	.741	.834	2.84
P3001	.431	.593	1.007	3.40
P5500	.391	.523	.726	2.47
P2001	.379	.616	.681	2.32
P9200	.297	.278	.489	2.23

Channel	S in ³	I in ⁴	Area in ²	Weight Lbs/Ft
P9000	.203	.164	.384	2.05
P3301	.202	.177	.797	2.70
P1000	.202	.185	.556	1.90
P1100	.166	.149	.417	1.42
P3000	.154	.121	.503	1.70
P4101	.141	.114	.574	1.94
P2000	.140	.124	.340	1.16
P4001	.125	.101	.478	1.64
P3300	.072	.037	.398	1.35
P4100	.053	.025	.287	.97
P4000	.048	.023	.239	.82

* Effective section properties.

P1000

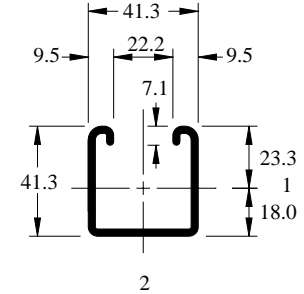
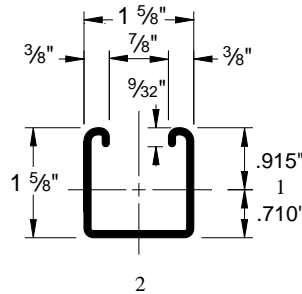
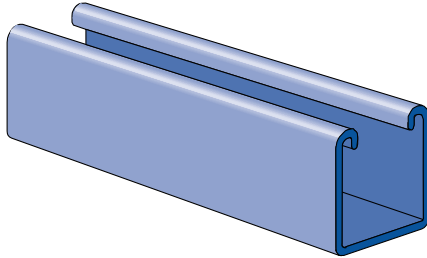

Pierced channels are found on pages 60 and 61.

Weight: 190 Lbs/C Ft (283 kg/100 m)

P1001

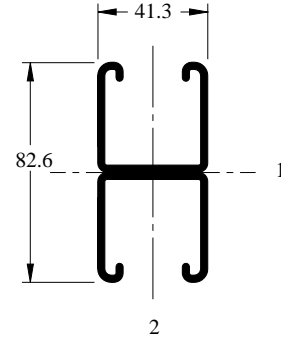
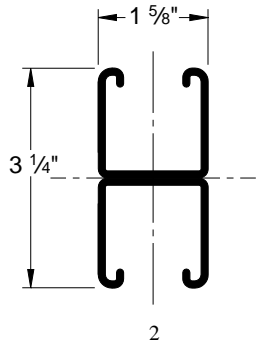
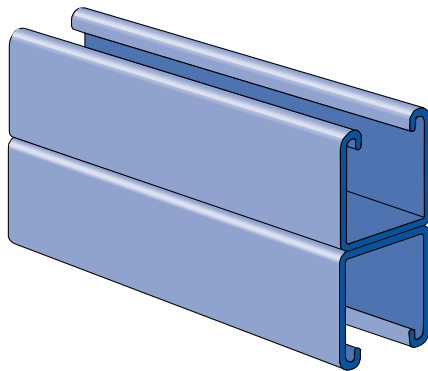

Weight: 380 Lbs/C Ft (566 kg/100 m)

BEAM LOAD*

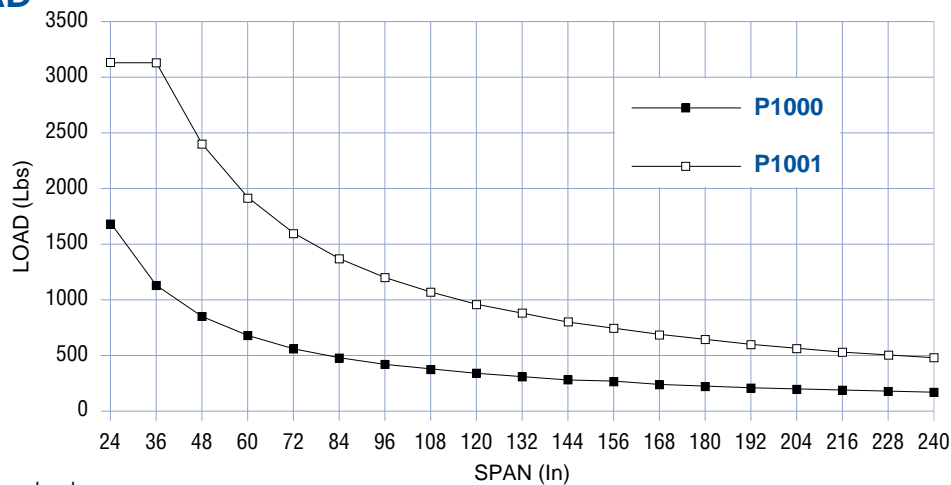

*Maximum allowable uniform load.

Channel	Weight		Allowable Moment		Material Thickness		Standard Lengths		Finishes				Other Materials	
	Lbs/Ft	kg/m	In-Lb	N•m	In	mm	10'	20'	PL	GR	HG	PG	SS	EA
P1000	1.90	2.8	5,080	570	.105	2.5	■	■	■	■	■	■	■	■
P1001	3.80	5.7	14,390	1630	.105	2.5	■	■	■	■	■	■	■	■

Nominal thickness of 12 gage strip steel is .105 inches.



BEAM LOADING DATA

Span		Channel	Max. Allowable Uniform Load		Deflection at Uniform Load		Uniform Loading at Deflections					
							Span/180		Span/240		Span/360	
In	mm		Lbs	kN	In	mm	Lbs	kN	Lbs	kN	Lbs	kN
24	610	P1000	1690	7.5	0.06	1	1690	7.5	1690	7.5	1690	7.5
		P1001	3130*	13.9	0.02	1	3130*	13.9	3130*	13.9	3130*	13.9
36	914	P1000	1130	5.0	0.13	3	1130	5.0	1130	5.0	900	4.0
		P1001	3130*	13.9	0.07	2	3130*	13.9	3130*	13.9	3130*	13.9
48	1219	P1000	850	3.8	0.22	6	850	3.8	760	3.4	510	2.3
		P1001	2400	10.7	0.13	3	2400	10.7	2400	10.7	2400	10.7
60	1524	P1000	680	3.0	0.35	9	650	2.9	490	2.2	320	1.4
		P1001	1920	8.5	0.20	5	1920	8.5	1920	8.5	1630	7.3
72	1829	P1000	560	2.5	0.50	13	450	2.0	340	1.5	220	1.0
		P1001	1600	7.1	0.28	7	1600	7.1	1600	7.1	1130	5.0
84	2134	P1000	480	2.1	0.68	17	330	1.5	250	1.1	170	0.8
		P1001	1370	6.1	0.39	10	1370	6.1	1240	5.5	830	3.7
96	2438	P1000	420	1.9	0.89	23	250	1.1	190	0.8	130	0.6
		P1001	1200	5.3	0.50	13	1200	5.3	950	4.2	640	2.8
108	2743	P1000	380	1.7	1.14	29	200	0.9	150	0.7	100	0.4
		P1001	1070	4.8	0.64	16	1000	4.4	750	3.3	500	2.2
120	3048	P1000	340	1.5	1.40	36	160	0.7	120	0.5	80	0.4
		P1001	960	4.3	0.79	20	810	3.6	610	2.7	410	1.8
144	3658	P1000	280	1.2	1.99	51	110	0.5	80	0.4	60	0.3
		P1001	800	3.6	1.13	29	560	2.5	420	1.9	280	1.2
168	4267	P1000	240	1.1	2.72	69	80	0.4	60	0.3	40	0.2
		P1001	690	3.1	1.55	39	410	1.8	310	1.4	210	0.9
192	4877	P1000	210	0.9	3.55	90	60	0.3	50	0.2	NR	NR
		P1001	600	2.7	2.02	51	320	1.4	240	1.1	160	0.7
216	5486	P1000	190	0.8	4.57	116	50	0.2	40	0.2	NR	NR
		P1001	530	2.4	2.53	64	250	1.1	190	0.8	130	0.6
240	6096	P1000	170	0.8	5.61	142	40	0.2	NR	NR	NR	NR
		P1001	480	2.1	3.15	80	200	0.9	150	0.7	100	0.4

*Load limited by spot weld shear.

NR = Not Recommended

Notes:

1. Above loads include the weight of the member. This weight must be deducted to arrive at the net allowable load the beam will support.
2. Long span beams should be supported in such a manner as to prevent rotation and twist.
3. Allowable uniformly distributed loads are listed for various simple spans, that is, a beam on two supports. If load is concentrated at the center of the span, multiply load from the table by 0.5 and corresponding deflection by 0.8.
4. Other lengths are also available



COLUMN LOADING DATA

Unbraced Height		Channel	Max. Allowable Load at Slot Face		Maximum Column Load Applied at C.G.							
					K = .65		K = .80		K = 1.0		K = 1.2	
In	mm		Lbs	kN	Lbs	kN	Lbs	kN	Lbs	kN	Lbs	kN
24	610	P1000	3400	15.1	9600	42.7	9500	42.3	9320	41.5	9100	40.5
		P1001	6360	28.3	23820	106.0	23560	104.8	23130	102.9	22610	100.6
36	914	P1000	3000	13.3	7640	34.0	7400	32.9	7000	31.1	6490	28.9
		P1001	6190	27.5	23190	103.2	22610	100.6	21640	96.3	20460	91.0
48	1219	P1000	2570	11.4	5910	26.3	5530	24.6	4980	22.2	4430	19.7
		P1001	5970	26.6	22310	99.2	21270	94.6	19560	87.0	17460	77.7
60	1524	P1000	2230	9.9	4780	21.3	4390	19.5	3850	17.1	3330	14.8
		P1001	5690	25.3	21180	94.2	19560	87.0	16870	75.0	13590	60.5
72	1829	P1000	1970	8.8	4090	18.2	3680	16.4	3140	14.0	2650	11.8
		P1001	5360	23.8	19790	88.0	17460	77.7	13590	60.5	9570	42.6
84	2134	P1000	1760	7.8	3600	16.0	3170	14.1	2630	11.7	2160	9.6
		P1001	4970	22.1	18150	80.7	14980	66.6	10130	45.1	7030	31.3
96	2438	P1000	1580	7.0	3220	14.3	2770	12.3	2240	10.0	1800	8.0
		P1001	4510	20.1	16270	72.4	12120	53.9	7750	34.5	5380	23.9
108	2743	P1000	1430	6.4	2910	12.9	2450	10.9	1930	8.6	**	**
		P1001	4030	17.9	14120	62.8	9570	42.6	6130	27.3	4250	18.9
120	3048	P1000	1290	5.7	2640	11.7	2180	9.7	**	**	**	**
		P1001	3610	16.1	11750	52.3	7750	34.5	4960	22.1	**	**

** $\frac{KL}{r} > 200$

ELEMENTS OF SECTION

Channel	Areas of Section		Axis 1 - 1						Axis 2 - 2					
			I		S		r		I		S		r	
	In ²	cm ²	In ⁴	cm ⁴	In ³	cm ³	In	cm	In ⁴	cm ⁴	In ³	cm ³	In	cm
P1000	.556	3.6	.185	7.7	.202	3.3	.577	1.5	.236	9.8	.290	4.7	.651	1.7
P1001	1.112	7.2	.930	38.7	.572	9.4	.915	2.3	.472	19.6	.580	9.5	.651	1.7

I - Moment of Inertia

S - Section Modulus

r - Radius of Gyration

P1001 A

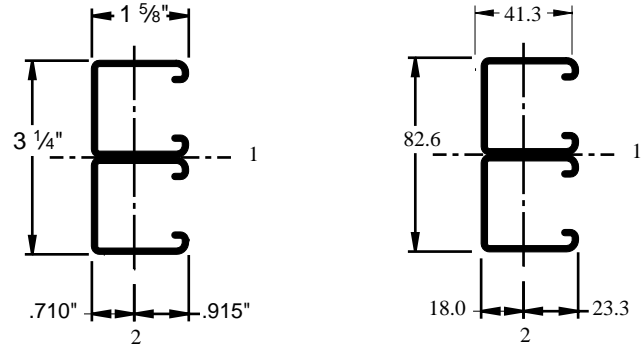
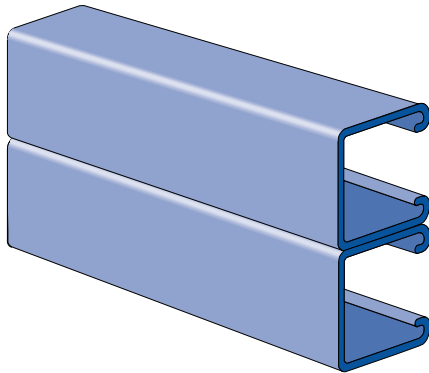

Weight: 380 Lbs/C Ft (566 kg/100 m)

P1001 B

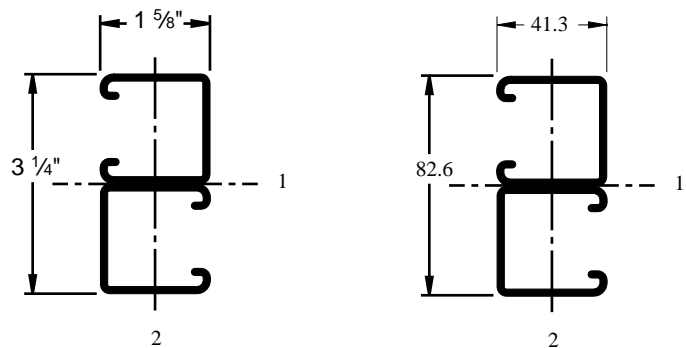
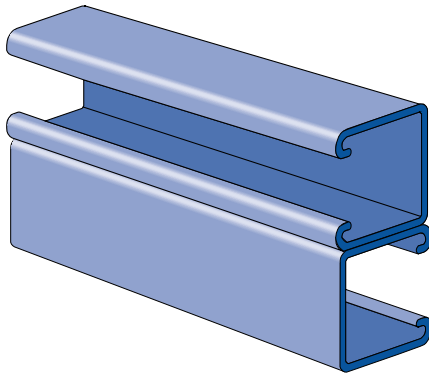

Weight: 380 Lbs/C Ft (566 kg/100 m)

P1001 C

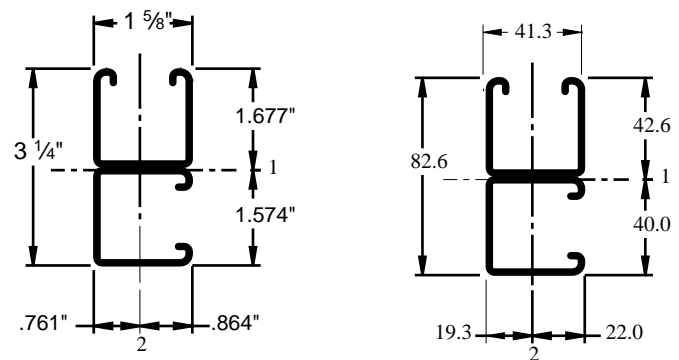
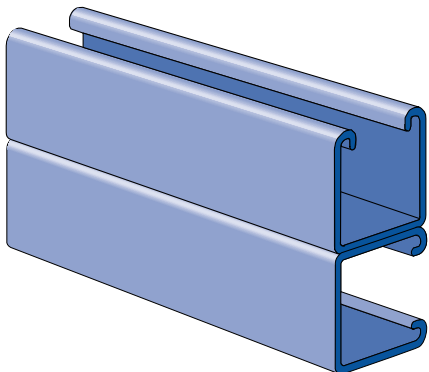

Weight: 380 Lbs/C Ft (566 kg/100 m)

Channel	Weight		Allowable Moment		Material Thickness		Standard Lengths		Finishes				Other Materials	
	Lbs/Ft	kg/m	In-Lb	Nm	In	mm	10'	20'	PL	GR	HG	PG	SS	EA
P1001 A	3.80	5.7	18,660	2110	.105	2.5	■	■	■	■	■	■		
P1001 B	3.80	5.7	18,660	2110	.105	2.5	■	■	■	■	■	■		
P1001 C	3.80	5.7	15,970	1800	.105	2.5	■	■	■	■	■	■		

P1001 3

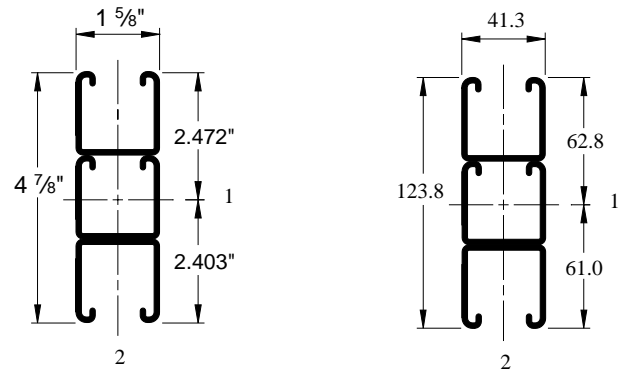
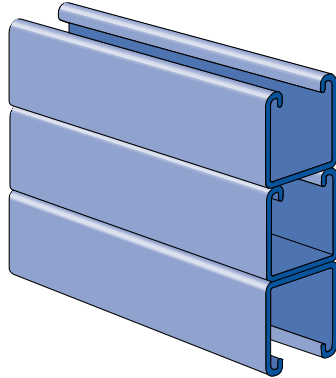

Weight: 570 Lbs/C Ft (848 kg/100 m)

P1001 A3

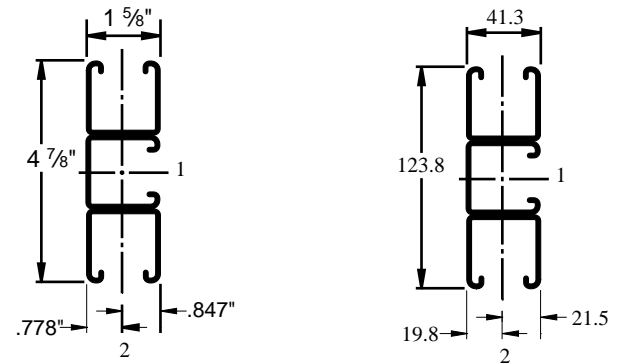
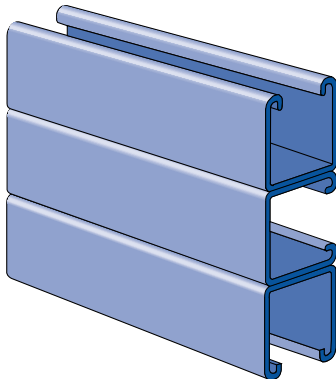

Weight: 570 Lbs/C Ft (848 kg/100 m)

P1001 B3

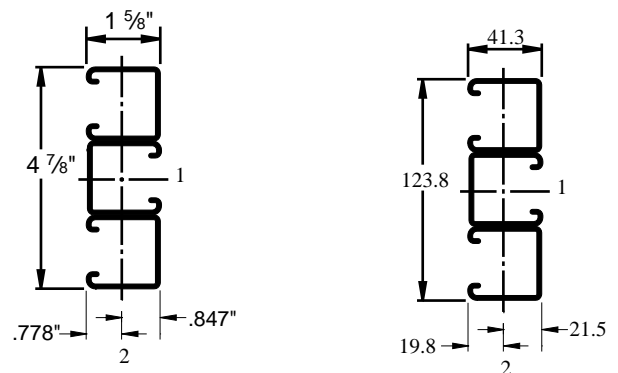
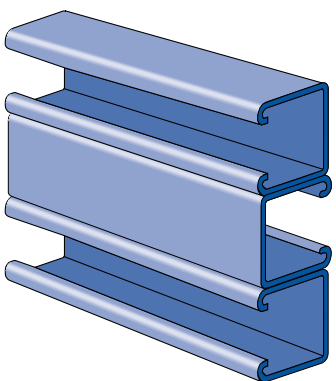

Weight: 570 Lbs/C Ft (848 kg/100 m)

Channel	Weight		Allowable Moment		Material Thickness		Standard Lengths		Finishes				Other Materials	
	Lbs/Ft	kg/m	In-Lb	N•m	In	mm	10'	20'	PL	GR	HG	PG	SS	EA
P1001 3	5.70	8.5	31,890	3600	.105	25	■	■	■	■	■	■		
P1001 A3	5.70	8.5	32,820	3710	.105	2.5	■	■	■	■	■	■		
P1001 B3	5.70	8.5	37,570	4240	.105	2.5	■	■	■	■	■	■		

P1001 C3

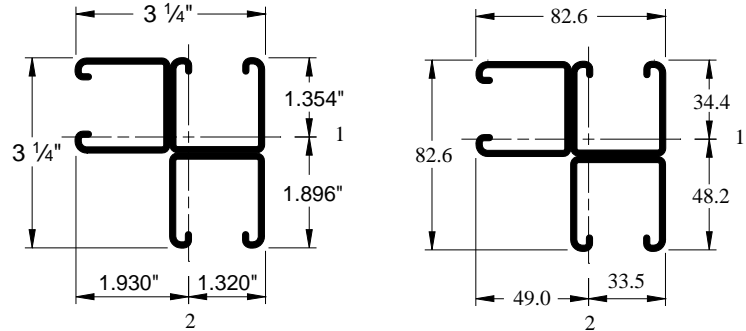
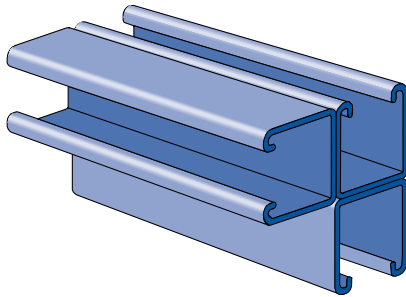

Weight: 570 Lbs/C Ft (848 kg/100 m)

P1001 D3

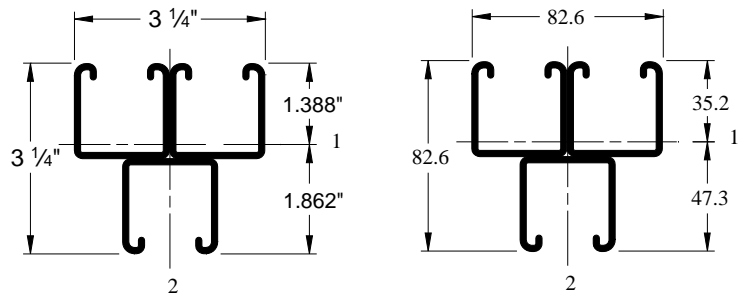
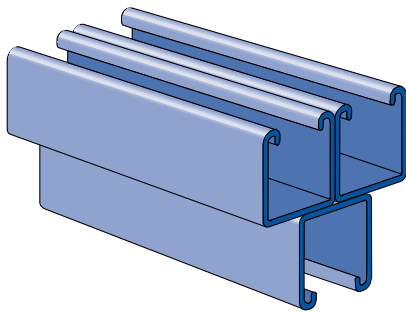

Weight: 570 Lbs/C Ft (848 kg/100 m)

P1001 C41

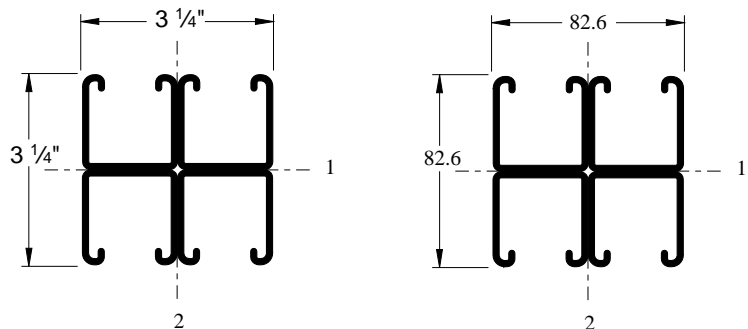
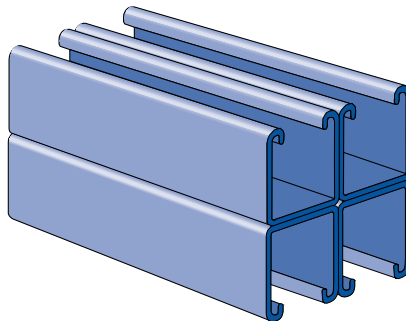

Weight: 760 Lbs/C Ft (1131 kg/100 m)

Channel	Weight		Allowable Moment		Material Thickness		Standard Lengths		Finishes				Other Materials	
	Lbs/Ft	kg/m	In-Lb	N*m	In	mm	10'	20'	PL	GR	HG	PG	SS	EA
P1001 C3	5.70	8.5	18,710	2110	.105	2.5	■	■	■	■	■	■		
P1001 D3	5.70	8.5	17,580	1990	.105	2.5	■	■	■	■	■	■		
P1001 C41	7.60	11.3	28,800	3250	.105	2.5	■	■	■	■	■	■		

P1003

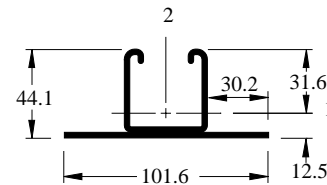
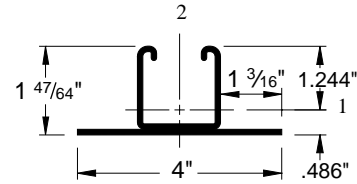
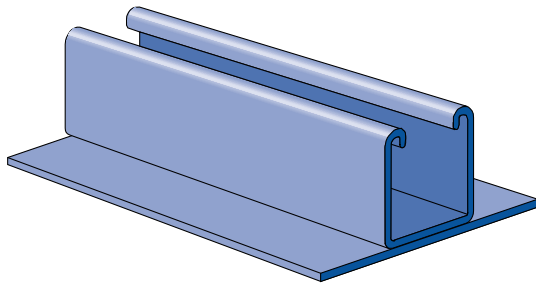

Weight: 332 Lbs/C Ft (494 kg/100 m)

P1004 A

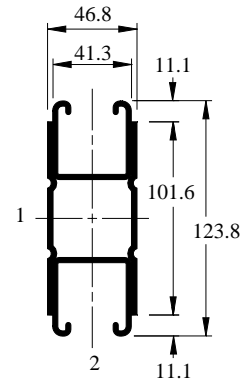
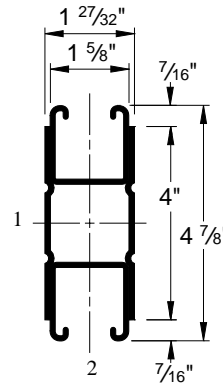
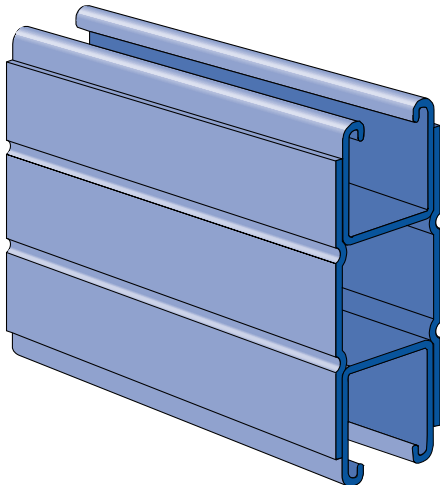

Weight: 670 Lbs/C Ft (997 kg/100 m)

Channel	Weight		Allowable Moment		Material Thickness		Standard Lengths		Finishes				Other Materials	
	Lbs/Ft	kg/m	In-Lb	N*m	In	mm	10'	20'	PL	GR	HG	PG	SS	EA
P1003	3.32	5.0	6,560	740	.105	2.5	■	■	■	■		■		
P1004 A	6.70	10.0	42,080	4750	.105	2.5	■	■	■	■	■	■		



BEAM LOADING DATA

Span		Channel	Max. Allowable Uniform Load		Deflection at Uniform Load		Uniform Loading at Deflections					
							Span/180		Span/240		Span/360	
In	mm		Lbs	kN	In	mm	Lbs	kN	Lbs	kN	Lbs	kN
24	610	P1004 A P1001C41	9350*†	41.6	0.01	0	9350*†	41.6	9350*†	41.6	9350*†	41.6
			6270*	27.9	0.02	1	6270*	27.9	6270*	27.9	6270*	27.9
36	914	P1004 A P1001C41	9350*†	41.6	0.05	1	9350*†	41.6	9350*†	41.6	9350*†	41.6
			6270*	27.9	0.07	2	6270*	27.9	6270*	27.9	6270*	27.9
48	1219	P1004 A P1001C41	7010	31.2	0.08	2	7010	31.2	7010	31.2	7010	31.2
			4800	21.4	0.13	3	4800	21.4	4800	21.4	4800	21.4
60	1524	P1004 A P1001C41	5610	25.0	0.13	3	5610	25.0	5610	25.0	5610	25.0
			3840	17.1	0.20	5	3840	17.1	3840	17.1	3250	14.5
72	1829	P1004 A P1001C41	4680	20.8	0.19	5	4680	20.8	4680	20.8	4680	20.8
			3200	14.2	0.28	7	3200	14.2	3200	14.2	2260	10.1
84	2134	P1004 A P1001C41	4010	17.8	0.26	7	4010	17.8	4010	17.8	3640	16.2
			2740	12.2	0.39	10	2740	12.2	2490	11.1	1660	7.4
96	2438	P1004 A P1001C41	3510	15.6	0.34	9	3510	15.6	3510	15.6	2790	12.4
			2400	10.7	0.50	13	2400	10.7	1910	8.5	1270	5.6
108	2743	P1004 A P1001C41	3120	13.9	0.43	11	3120	13.9	3120	13.9	2200	9.8
			2130	9.5	0.64	16	2010	8.9	1510	6.7	1000	4.4
120	3048	P1004 A P1001C41	2810	12.5	0.53	13	2810	12.5	2670	11.9	1780	7.9
			1920	8.5	0.79	20	1630	7.3	1220	5.4	810	3.6
144	3658	P1004 A P1001C41	2340	10.4	0.76	19	2340	10.4	1860	8.3	1240	5.5
			1600	7.1	1.13	29	1130	5.0	850	3.8	560	2.5
168	4267	P1004 A P1001C41	2000	8.9	1.03	26	1820	8.1	1360	6.0	910	4.0
			1370	6.1	1.54	39	830	3.7	620	2.8	410	1.8
192	4877	P1004 A P1001C41	1750	7.8	1.34	34	1390	6.2	1040	4.6	700	3.1
			1200	5.3	2.02	51	640	2.8	480	2.1	320	1.4
216	5486	P1004 A P1001C41	1560	6.9	1.70	43	1100	4.9	830	3.7	550	2.4
			1070	4.8	2.56	65	500	2.2	380	1.7	250	1.1
240	6096	P1004 A P1001C41	1400	6.2	2.09	53	890	4.0	670	3.0	450	2.0
			960	4.3	3.15	80	410	1.8	300	1.3	200	0.9

*Load limited by spot weld shear. †Bearing load may govern capacity. See page 67.

Notes:

1. Above loads include the weight of the member. This weight must be deducted to arrive at the net allowable load the beam will support.
2. Long span beams should be supported in such a manner as to prevent rotation and twist.
3. Allowable uniformly distributed loads are listed for various simple spans, that is, a beam on two supports. If load is concentrated at the center of the span, multiply load from the table by 0.5 and corresponding deflection by 0.8.
4. Other lengths are also available on request.



COLUMN LOADING DATA

Unbraced Height		Channel	Max. Allowable Load at Slot Face		Maximum Column Load Applied at C.G.							
In	mm		Lbs	kN	K = .65		K = .80		K = 1.0		K = 1.2	
						Lbs	kN	Lbs	kN	Lbs	kN	Lbs
24	610	P1004 A P1001C41	12190 12770	54.2 56.8	42600 48120	189.5 214.0	42250 47860	187.9 212.9	41680 47420	185.4 210.9	40990 46890	182.3 208.6
36	914	P1004 A P1001C41	12010 12510	53.4 55.6	41760 47480	185.8 211.2	40990 46890	182.3 208.6	39700 45910	176.6 204.2	38130 44720	169.6 198.9
48	1219	P1004 A P1001C41	11750 12160	52.3 54.1	40590 46590	180.6 207.2	39210 45540	174.4 202.6	36930 43800	164.3 194.8	34140 41680	151.9 185.4
60	1524	P1004 A P1001C41	11420 11730	50.8 52.2	39080 45440	173.8 202.1	36930 43800	164.3 194.8	33360 41090	148.4 182.8	29000 37770	129.0 168.0
72	1829	P1004 A P1001C41	11010 11230	49.0 50.0	37240 44040	165.7 195.9	34140 41680	151.9 185.4	29000 37770	129.0 168.0	22730 32990	101.1 146.7
84	2134	P1004 A P1001C41	10510 10680	46.8 47.5	35060 42380	156.0 188.5	30840 39170	137.2 174.2	23850 33850	106.1 150.6	16740 27350	74.5 121.7
96	2438	P1004 A P1001C41	9910 10090	44.1 44.9	32550 40470	144.8 180.0	27040 36270	120.3 161.3	18450 29320	82.1 130.4	12820 21270	57.0 94.6
108	2743	P1004 A P1001C41	9160 9470	40.7 42.1	29710 38310	132.2 170.4	22730 32990	101.1 146.8	14580 24200	64.9 107.6	10130 16800	45.1 74.7
120	3048	P1004 A P1001C41	8310 8820	37.0 39.2	26530 35880	118.0 159.6	18450 29320	82.1 130.4	11810 19600	52.5 87.2	8200 13610	36.5 60.5

ELEMENTS OF SECTION

Channel	Areas of Section		Axis 1 - 1						Axis 2 - 2					
			I		S		r		I		S		r	
	In ²	cm ²	In ⁴	cm ⁴	In ³	cm ³	In	cm	In ⁴	cm ⁴	In ³	cm ³	In	cm
P1004 A	1.978	12.8	4.079	169.8	1.673	27.4	1.436	3.6	1.121	46.7	1.204	19.7	.753	1.9
P1001 C41	2.223	14.3	1.860	77.4	1.145	18.8	.915	2.3	2.411	100.4	1.484	24.3	1.041	2.6

I - Moment of Inertia

S - Section Modulus

r - Radius of Gyration



P1100

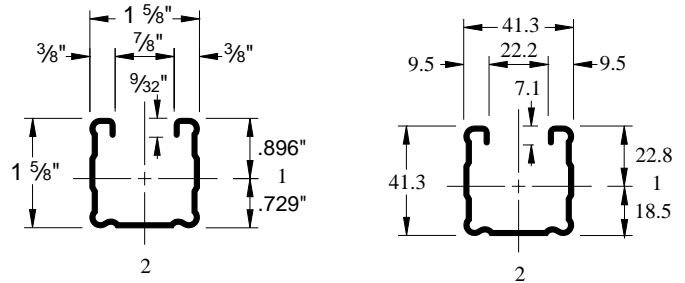
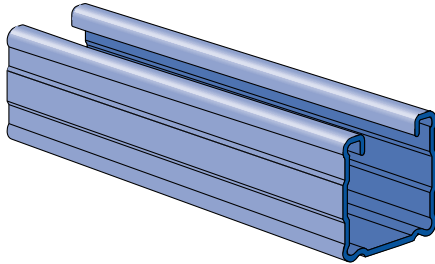

Pierced channels are found on pages 60 and 61.

Weight: 142 Lbs/C Ft (211 kg/100 m)

P1101

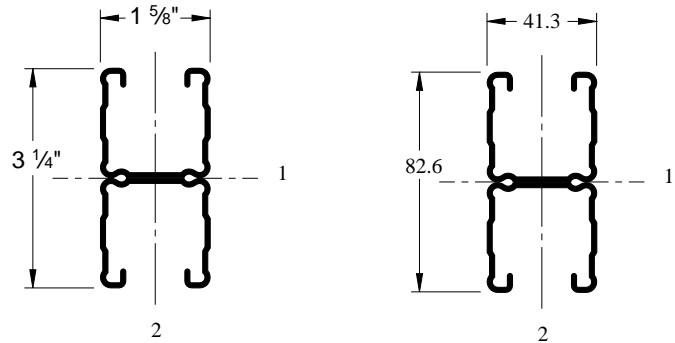
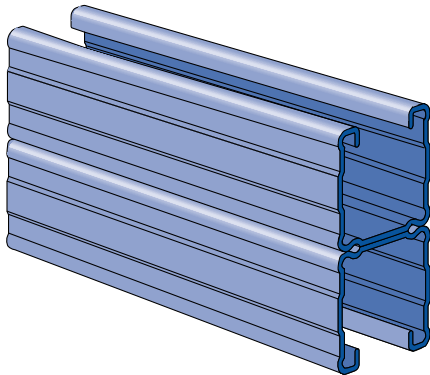

Weight: 284 Lbs/C Ft (423 kg/100 m)

BEAM LOAD*

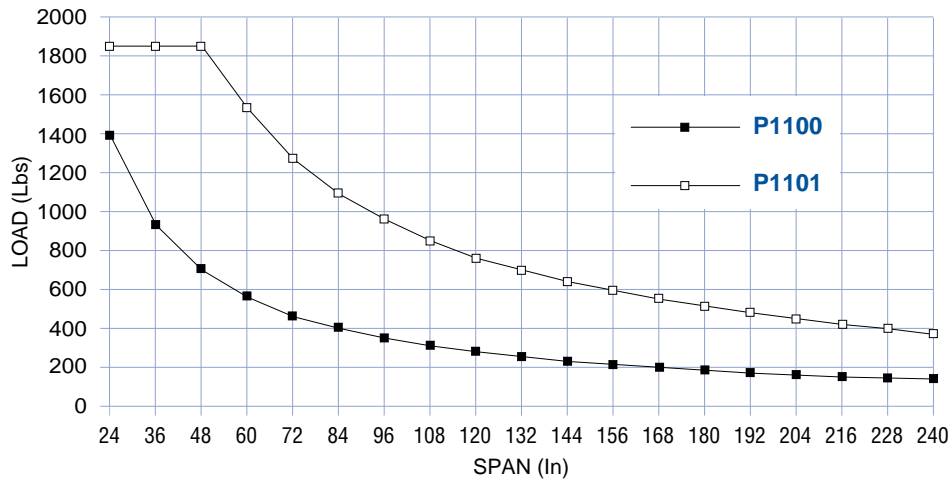

*Maximum allowable uniform load.

Channel	Weight		Allowable Moment		Material Thickness		Standard Lengths		Finishes				Other Materials	
	Lbs/Ft	kg/m	In-Lb	N*m	In	mm	10'	20'	PL	GR	HG	PG	SS	EA
P1100	1.42	2.1	4,170	470	.075	1.9	■	■	■	■	■	■	■	
P1101	2.84	4.2	11,470	1300	.075	1.9	■	■	■	■	■	■	■	

Nominal thickness of 14 gage strip steel is .075 inches.

P1101 A

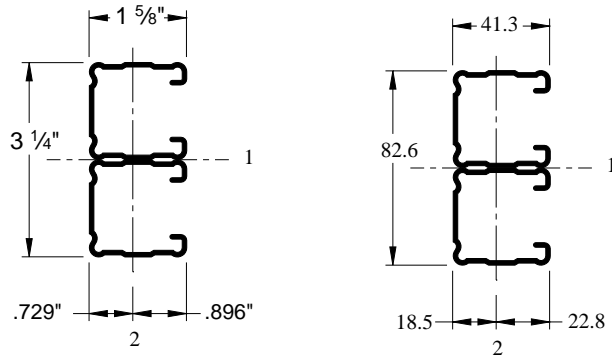
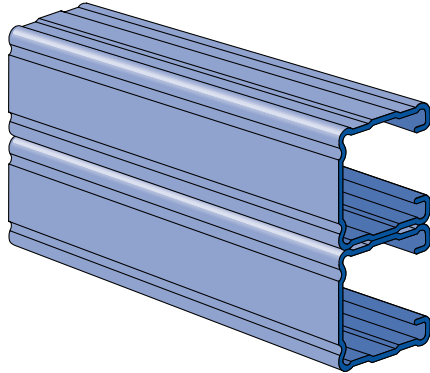

Weight: 284 Lbs/C Ft (423 kg/100 m)

P1101 B

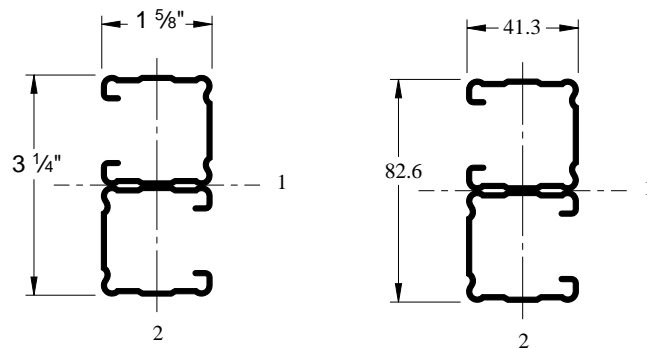
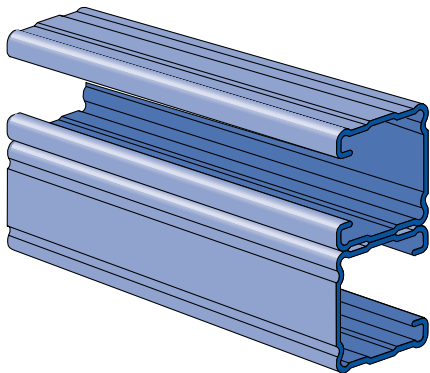

Weight: 284 Lbs/C Ft (423 kg/100 m)

P1101 C

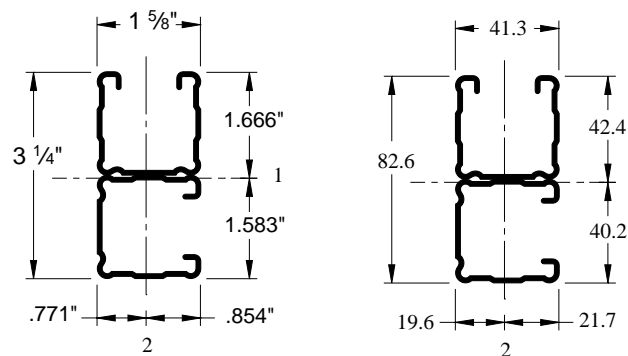
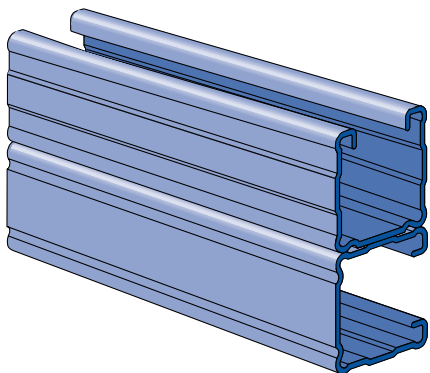

Weight: 284 Lbs/C Ft (423 kg/100 m)

Channel	Weight		Allowable Moment		Material Thickness		Standard Lengths		Finishes				Other Materials	
	Lbs/Ft	kg/m	In-Lb	N*m	In	mm	10'	20'	PL	GR	HG	PG	SS	EA
P1101 A	2.84	4.2	14,180	1600	.075	1.9	■	■	■	■	■	■		
P1101 B	2.84	4.2	14,180	1600	.075	1.9	■	■	■	■	■	■		
P1101 C	2.84	4.2	12,500	1410	.075	1.9	■	■	■	■	■	■		



BEAM LOADING DATA

Span		Channel	Max. Allowable Uniform Load		Deflection at Uniform Load		Uniform Loading at Deflections					
							Span/180		Span/240		Span/360	
In	mm		Lbs	kN	In	mm	Lbs	kN	Lbs	kN	Lbs	kN
24	610	P1100	1390	6.2	0.06	1	1390	6.2	1390	6.2	1390	6.2
		P1101	1850*	8.2	0.02	1	1850*	8.2	1850*	8.2	1850*	8.2
36	914	P1100	930	4.1	0.13	3	930	4.1	930	4.1	720	3.2
		P1101	1850*	8.2	0.05	1	1850*	8.2	1850*	8.2	1850*	8.2
48	1219	P1100	700	3.1	0.23	6	700	3.1	610	2.7	410	1.8
		P1101	1850*	8.2	0.12	3	1850*	8.2	1850*	8.2	1850*	8.2
60	1524	P1100	560	2.5	0.36	9	520	2.3	390	1.7	260	1.2
		P1101	1530	6.8	0.20	5	1530	6.8	1530	6.8	1300	5.8
72	1829	P1100	460	2.0	0.51	13	360	1.6	270	1.2	180	0.8
		P1101	1270	5.6	0.28	7	1270	5.6	1270	5.6	900	4.0
84	2134	P1100	400	1.8	0.70	18	270	1.2	200	0.9	130	0.6
		P1101	1090	4.8	0.38	10	1090	4.8	990	4.4	660	2.9
96	2438	P1100	350	1.6	0.92	23	200	0.9	150	0.7	100	0.4
		P1101	960	4.3	0.51	13	960	4.3	760	3.4	510	2.3
108	2743	P1100	310	1.4	1.16	29	160	0.7	120	0.5	80	0.4
		P1101	850	3.8	0.64	16	800	3.6	600	2.7	400	1.8
120	3048	P1100	280	1.2	1.43	36	130	0.6	100	0.4	70	0.3
		P1101	760	3.4	0.78	20	650	2.9	490	2.2	320	1.4
144	3658	P1100	230	1.0	2.03	52	90	0.4	70	0.3	50	0.2
		P1101	640	2.8	1.14	29	450	2.0	340	1.5	220	1.0
168	4267	P1100	200	0.9	2.81	71	70	0.3	50	0.2	30	0.1
		P1101	550	2.4	1.55	39	330	1.5	250	1.1	170	0.8
192	4877	P1100	170	0.8	3.56	91	50	0.2	40	0.2	30	0.1
		P1101	480	2.1	2.02	51	250	1.1	190	0.8	130	0.6
216	5486	P1100	150	0.7	4.48	114	40	0.2	30	0.1	NR	NR
		P1101	420	1.9	2.52	64	200	0.9	150	0.7	100	0.4
240	6096	P1100	140	0.6	5.73	146	30	0.1	NR	NR	NR	NR
		P1101	380	1.7	3.13	79	160	0.7	120	0.5	80	0.4

*Load limited by spot weld shear.

NR = Not Recommended

Notes:

1. Above loads include the weight of the member. This weight must be deducted to arrive at the net allowable load the beam will support.
2. Long span beams should be supported in such a manner as to prevent rotation and twist.
3. Allowable uniformly distributed loads are listed for various simple spans, that is, a beam on two supports. If load is concentrated at the center of the span, multiply load from the table by 0.5 and corresponding deflection by 0.8.
4. Other Lengths are also available on request.



COLUMN LOADING DATA

Unbraced Height		Channel	Max. Allowable Load at Slot Face		Maximum Column Load Applied at C.G.							
					K = .65		K = .80		K = 1.0		K = 1.2	
In	mm		Lbs	kN	Lbs	kN	Lbs	kN	Lbs	kN	Lbs	kN
24	610	P1100	2720	12.1	7160	31.8	7090	31.5	6960	31.0	6800	30.2
		P1101	4990	22.2	17880	79.5	17690	78.7	17380	77.3	17000	75.6
36	914	P1100	2330	10.4	5360	23.8	5190	23.1	4900	21.8	4530	20.2
		P1101	4860	21.6	17420	77.5	17000	75.6	16300	72.5	15440	68.7
48	1219	P1100	1890	8.4	3730	16.6	3540	15.7	3250	14.5	2940	13.1
		P1101	4690	20.9	16780	74.6	16030	71.3	14780	65.7	13260	59.0
60	1524	P1100	1590	7.1	2880	12.8	2690	12.0	2430	10.8	2160	9.6
		P1101	4470	19.9	15960	71.0	14780	65.7	12840	57.1	10460	46.5
72	1829	P1100	1390	6.2	2390	10.6	2210	9.8	1950	8.7	1710	7.6
		P1101	4210	18.7	14960	66.5	13260	59.0	10460	46.5	7420	33.0
84	2134	P1100	1230	5.5	2070	9.2	1890	8.4	1640	7.3	1400	6.2
		P1101	3920	17.4	13770	61.3	11460	51.0	7850	34.9	5450	24.2
96	2438	P1100	1100	4.9	1850	8.2	1650	7.3	1400	6.2	1180	5.2
		P1101	3560	15.8	12400	55.2	9390	41.8	6010	26.7	4180	18.6
108	2743	P1100	1000	4.4	1670	7.4	1470	6.5	1220	5.4	**	**
		P1101	3180	14.1	10850	48.3	7420	33.0	4750	21.1	3300	14.7
120	3048	P1100	910	4.0	1530	6.8	1330	5.9	**	**	**	**
		P1101	2850	12.7	9110	40.5	6010	26.7	3850	17.1	**	**

** $\frac{KL}{r} > 200$

ELEMENTS OF SECTION

Channel	Areas of Section		Axis 1 - 1						Axis 2 - 2					
			I		S		r		I		S		r	
	In ²	cm ²	In ⁴	cm ⁴	In ³	cm ³	In	cm	In ⁴	cm ⁴	In ³	cm ³	In	cm
P1100	.417	2.7	.149	6.2	.166	2.7	.597	1.5	.183	7.6	.225	3.7	.662	1.7
P1101	.834	5.4	.741	30.8	.456	7.5	.942	2.4	.366	15.2	.451	7.4	.662	1.7

I - Moment of Inertia

S - Section Modulus

r - Radius of Gyration

P2000

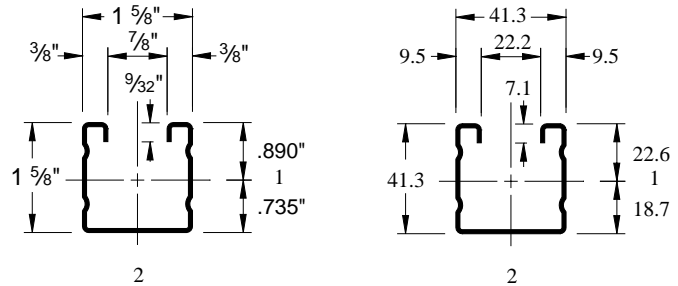
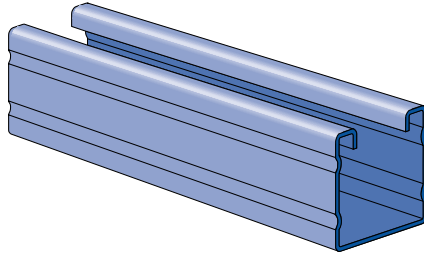

Pierced channels are found on pages 60 and 61.

Weight: 116 Lbs/C Ft (173 kg/100 m)

P2001

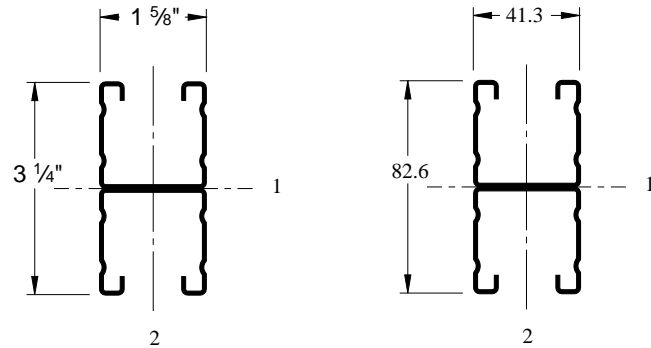
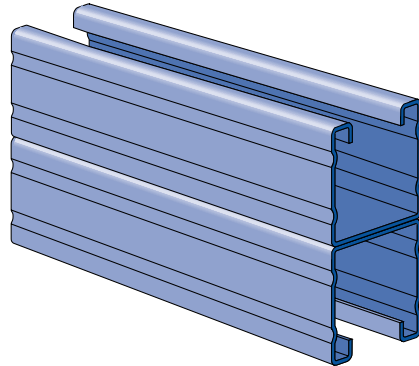

Weight: 232 Lbs/C Ft (345 kg/100 m)

BEAM LOAD*

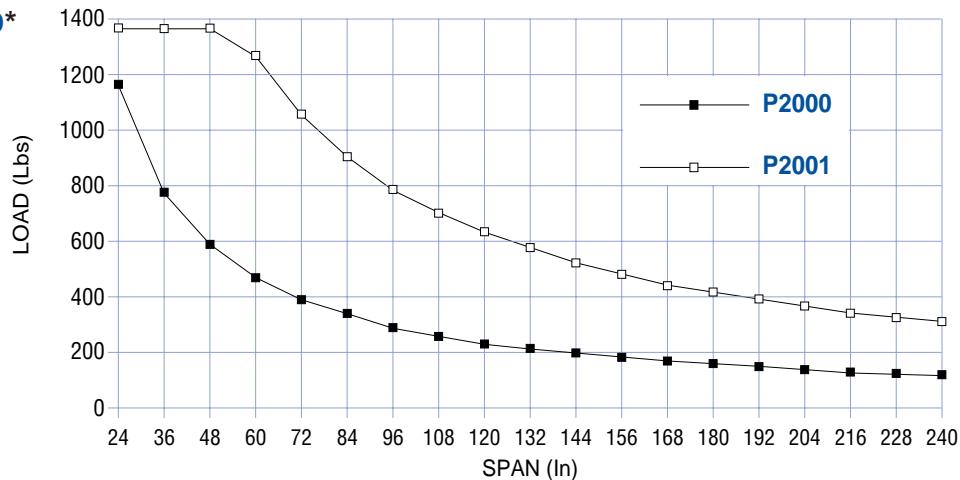

*Maximum allowable uniform load.

Channel	Weight		Allowable Moment		Material Thickness		Standard Lengths		Finishes				Other Materials	
	Lbs/Ft	kg/m	In-Lb	N*m	In	mm	10'	20'	PL	GR	HG	PG	SS	EA
P2000	1.16	1.7	3,520	400	.060	1.5	■	■	■	■	■	■		
P2001	2.32	3.4	9,530	1080	.060	1.5	■	■	■	■	■	■		

Nominal thickness of 16 gage strip steel is .060 inches.



P2001 A

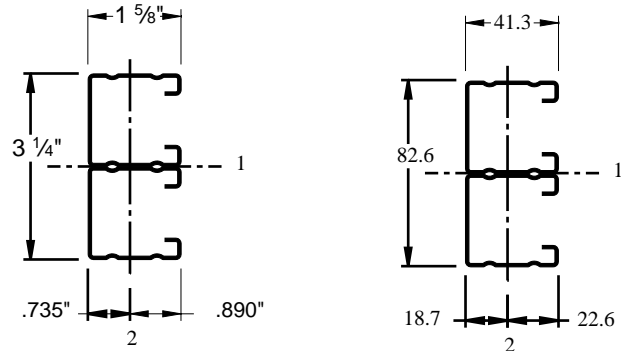
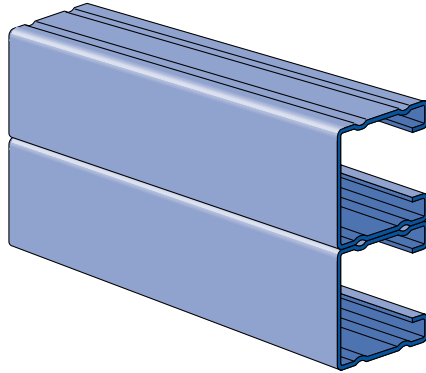

Weight: 232 Lbs/C Ft (345 kg/100 m)

P2001 B

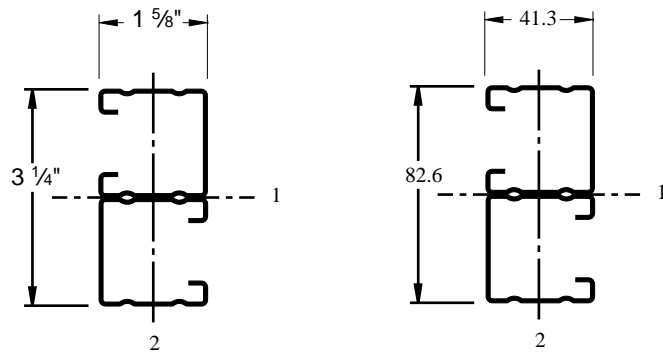
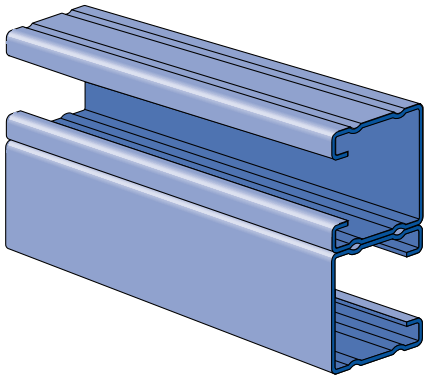

Weight: 232 Lbs/C Ft (345 kg/100 m)

P2001 C

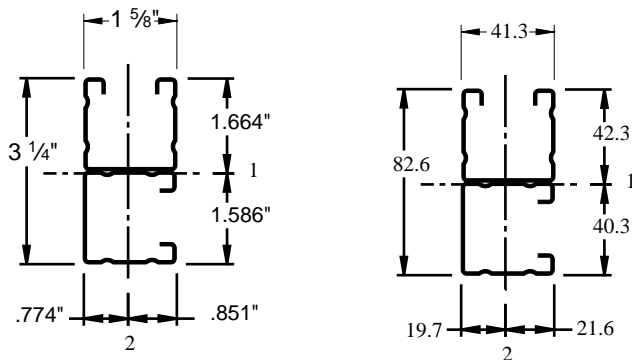
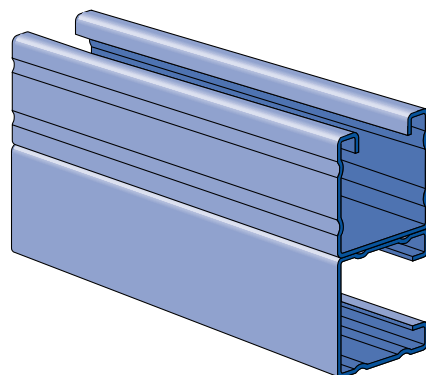

Weight: 232 Lbs/C Ft (345 kg/100 m)

Channel	Weight		Allowable Moment		Material Thickness		Standard Lengths		Finishes				Other Materials	
	Lbs/Ft	kg/m	In-Lb	N*m	In	mm	10'	20'	PL	GR	HG	PG	SS	EA
P2001 A	2.32	3.4	11,640	1320	.060	1.5	■	■	■	■	■	■		
P2001 B	2.32	3.4	11,640	1320	.060	1.5	■	■	■	■	■	■		
P2001 C	2.32	3.4	10,340	1170	.060	1.5	■	■	■	■	■	■		



BEAM LOADING DATA

Span		Channel	Max. Allowable Uniform Load		Deflection at Uniform Load		Uniform Loading at Deflections					
							Span/180		Span/240		Span/360	
In	mm		Lbs	kN	In	mm	Lbs	kN	Lbs	kN	Lbs	kN
24	610	P2000	1170	5.2	0.06	1	1170	5.2	1170	5.2	1170	5.2
		P2001	1370*	6.1	0.01	0	1370*	6.1	1370*	6.1	1370*	6.1
36	914	P2000	780	3.5	0.13	3	780	3.5	780	3.5	600	2.7
		P2001	1370*	6.1	0.05	1	1370*	6.1	1370*	6.1	1370*	6.1
48	1219	P2000	590	2.6	0.23	6	590	2.6	510	2.3	340	1.5
		P2001	1370*	6.1	0.11	3	1370*	6.1	1370*	6.1	1370*	6.1
60	1524	P2000	470	2.1	0.36	9	430	1.9	330	1.5	220	1.0
		P2001	1270	5.6	0.20	5	1270	5.6	1270	5.6	1080	4.8
72	1829	P2000	390	1.7	0.52	13	300	1.3	230	1.0	150	0.7
		P2001	1060	4.7	0.28	7	1060	4.7	1060	4.7	750	3.3
84	2134	P2000	340	1.5	0.72	18	220	1.0	170	0.8	110	0.5
		P2001	910	4.0	0.39	10	910	4.0	820	3.6	550	2.4
96	2438	P2000	290	1.3	0.91	23	170	0.8	130	0.6	80	0.4
		P2001	790	3.5	0.50	13	790	3.5	630	2.8	420	1.9
108	2743	P2000	260	1.2	1.17	30	130	0.6	100	0.4	70	0.3
		P2001	710	3.2	0.64	16	660	2.9	500	2.2	330	1.5
120	3048	P2000	230	1.0	1.41	36	110	0.5	80	0.4	50	0.2
		P2001	640	2.8	0.79	20	540	2.4	400	1.8	270	1.2
144	3658	P2000	200	0.9	2.13	54	80	0.4	60	0.3	40	0.2
		P2001	530	2.4	1.13	29	370	1.6	280	1.2	190	0.8
168	4267	P2000	170	0.8	2.87	73	60	0.3	40	0.2	30	0.1
		P2001	450	2.0	1.53	39	270	1.2	210	0.9	140	0.6
192	4877	P2000	150	0.7	3.78	96	40	0.2	30	0.1	NR	NR
		P2001	400	1.8	2.03	52	210	0.9	160	0.7	110	0.5
216	5486	P2000	130	0.6	4.66	118	30	0.1	30	0.1	NR	NR
		P2001	350	1.6	2.53	64	170	0.8	120	0.5	80	0.4
240	6096	P2000	120	0.5	5.90	150	30	0.1	NR	NR	NR	NR
		P2001	320	1.4	3.17	81	130	0.6	100	0.4	70	0.3

*Load limited by spot weld shear.

NR = Not Recommended

Notes:

1. Above loads include the weight of the member. This weight must be deducted to arrive at the net allowable load the beam will support.
2. Long span beams should be supported in such a manner as to prevent rotation and twist.
3. Allowable uniformly distributed loads are listed for various simple spans, that is, a beam on two supports. If load is concentrated at the center of the span, multiply load from the table by 0.5 and corresponding deflection by 0.8.
4. Other lengths are also available on request.



COLUMN LOADING DATA

Unbraced Height		Channel	Max. Allowable Load at Slot Face		Maximum Column Load Applied at C.G.							
					K = .65		K = .80		K = 1.0		K = 1.2	
In	mm		Lbs	kN	Lbs	kN	Lbs	kN	Lbs	kN	Lbs	kN
24	610	P2000	2260	10.1	5660	25.2	5600	24.9	5500	24.5	5370	23.9
		P2001	4120	18.3	14600	64.9	14450	64.3	14200	63.2	13900	61.8
36	914	P2000	1750	7.8	3460	15.4	3350	14.9	3170	14.1	2970	13.2
		P2001	4020	17.9	14240	63.3	13900	61.8	13330	59.3	12640	56.2
48	1219	P2000	1230	5.5	1950	8.7	1880	8.4	1780	7.9	1670	7.4
		P2001	3880	17.3	13720	61.0	13120	58.4	12110	53.9	10890	48.4
60	1524	P2000	900	4.0	1250	5.6	1210	5.4	1140	5.1	1070	4.8
		P2001	3700	16.5	13060	58.1	12110	53.9	10550	46.9	8640	38.4
72	1829	P2000	680	3.0	870	3.9	840	3.7	790	3.5	740	3.3
		P2001	3490	15.5	12250	54.5	10890	48.4	8640	38.4	6150	27.4
84	2134	P2000	520	2.3	640	2.8	610	2.7	580	2.6	550	2.4
		P2001	3250	14.5	11300	50.3	9440	42.0	6510	29.0	4520	20.1
96	2438	P2000	410	1.8	490	2.2	470	2.1	450	2.0	420	1.9
		P2001	2960	13.2	10190	45.3	7770	34.6	4990	22.2	3460	15.4
108	2743	P2000	330	1.5	380	1.7	370	1.6	350	1.6	**	**
		P2001	2640	11.7	8950	39.8	6150	27.4	3940	17.5	2740	12.2
120	3048	P2000	280	1.2	310	1.4	300	1.3	290	1.3	**	**
		P2001	2370	10.5	7550	33.6	4990	22.2	3190	14.2	**	**

** $\frac{KL}{T} > 200$

ELEMENTS OF SECTION

Channel	Areas of Section		Axis 1 - 1						Axis 2 - 2					
			I		S		r		I		S		r	
	In ²	cm ²	In ⁴	cm ⁴	In ³	cm ³	In	cm	In ⁴	cm ⁴	In ³	cm ³	In	cm
P2000	.340	2.2	.124	5.2	.140	2.3	.605	1.5	.151	6.3	.186	3.0	.667	1.7
P2001	.681	4.4	.616	25.6	.379	6.2	.951	2.4	.303	12.6	.373	6.1	.667	1.7

I - Moment of Inertia

S - Section Modulus

r - Radius of Gyration



P3000

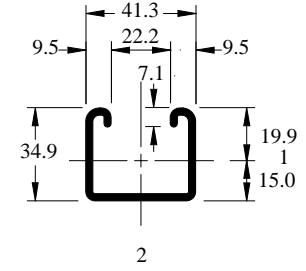
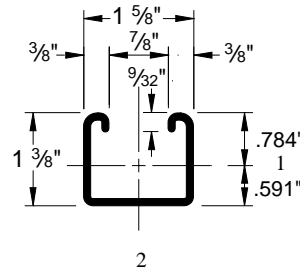
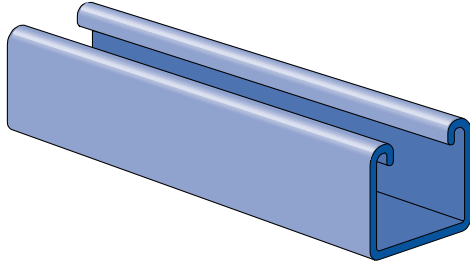

Pierced channels are found on pages 60 and 61.

Weight: 170 Lbs/C Ft (253 kg/100 m)

P3001

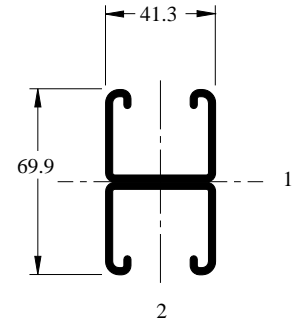
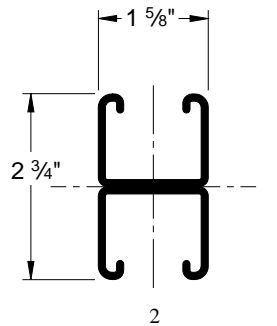
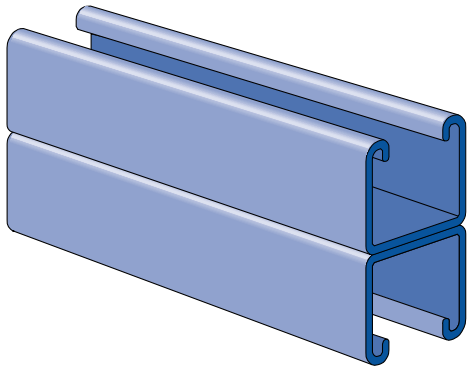

Weight: 340 Lbs/C Ft (506 kg/100 m)

BEAM LOAD*

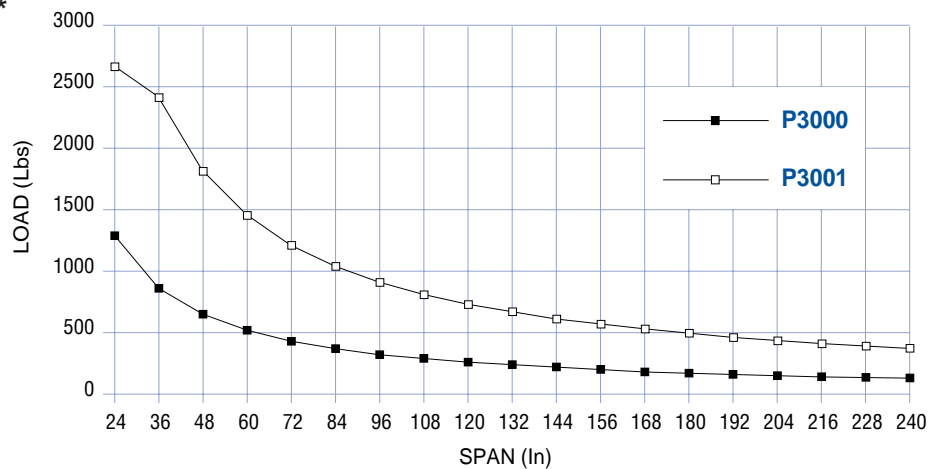

* Maximum allowable uniform load.

Channel	Weight		Allowable Moment		Material Thickness		Standard Lengths		Finishes				Other Materials	
	Lbs/Ft	kg/m	In-Lb	N*m	In	mm	10'	20'	PL	GR	HG	PG	SS	EA
P3000	1.70	2.5	3,870	440	.105	2.7	■	■	■	■	■	■	■	
P3001	3.40	5.1	10,840	1220	.105	2.7	■	■	■	■	■	■	■	

Nominal thickness of 12 gage strip steel is .105 inches.



BEAM LOADING DATA

Span		Channel	Max. Allowable Uniform Load		Deflection at Uniform Load		Uniform Loading at Deflections					
							Span/180		Span/240		Span/360	
In	mm		Lbs	kN	In	mm	Lbs	kN	Lbs	kN	Lbs	kN
24	610	P3000	1290	5.7	0.07	2	1290	5.7	1290	5.7	1290	5.7
		P3001	2660*	11.8	0.03	1	2660*	11.8	2660*	11.8	2660*	11.8
36	914	P3000	860	3.8	0.15	4	860	3.8	860	3.8	590	2.6
		P3001	2410	10.7	0.08	2	2410	10.7	2410	10.7	2410	10.7
48	1219	P3000	650	2.9	0.26	7	650	2.9	500	2.2	330	1.5
		P3001	1810	8.1	0.15	4	1810	8.1	1810	8.1	1620	7.2
60	1524	P3000	520	2.3	0.41	10	420	1.9	320	1.4	210	0.9
		P3001	1450	6.4	0.23	6	1450	6.4	1450	6.4	1040	4.6
72	1829	P3000	430	1.9	0.59	15	290	1.3	220	1.0	150	0.7
		P3001	1200	5.3	0.33	8	1200	5.3	1080	4.8	720	3.2
84	2134	P3000	370	1.6	0.80	20	220	1.0	160	0.7	110	0.5
		P3001	1030	4.6	0.45	12	1030	4.6	790	3.5	530	2.4
96	2438	P3000	320	1.4	1.03	26	170	0.8	120	0.5	80	0.4
		P3001	900	4.0	0.59	15	810	3.6	610	2.7	400	1.8
108	2743	P3000	290	1.3	1.33	34	130	0.6	100	0.4	70	0.3
		P3001	800	3.6	0.75	19	640	2.8	480	2.1	320	1.4
120	3048	P3000	260	1.2	1.64	42	110	0.5	80	0.4	50	0.2
		P3001	720	3.2	0.93	24	520	2.3	390	1.7	260	1.2
144	3658	P3000	220	1.0	2.40	61	70	0.3	60	0.3	40	0.2
		P3001	600	2.7	1.33	34	360	1.6	270	1.2	180	0.8
168	4267	P3000	180	0.8	3.11	79	50	0.2	40	0.2	30	0.1
		P3001	520	2.3	1.84	47	260	1.2	200	0.9	130	0.6
192	4877	P3000	160	0.7	4.13	105	40	0.2	30	0.1	NR	NR
		P3001	450	2.0	2.37	60	200	0.9	150	0.7	100	0.4
216	5486	P3000	140	0.6	5.15	131	NR	NR	NR	NR	NR	NR
		P3001	400	1.8	3.00	76	160	0.7	120	0.5	80	0.4
240	6096	P3000	130	0.6	6.56	167	NR	NR	NR	NR	NR	NR
		P3001	360	1.6	3.70	94	130	0.6	100	0.4	60	0.3

*Load limited by spot weld shear.

NR = Not Recommended

Notes:

1. Above loads include the weight of the member. This weight must be deducted to arrive at the net allowable load the beam will support.
2. Long span beams should be supported in such a manner as to prevent rotation and twist.
3. Allowable uniformly distributed loads are listed for various simple spans, that is, a beam on two supports. If load is concentrated at the center of the span, multiply load from the table by 0.5 and corresponding deflection by 0.8.
4. Other lengths are also available on request.



COLUMN LOADING DATA

Unbraced Height		Channel	Max. Allowable Load at Slot Face		Maximum Column Load Applied at C.G.							
					K = .65		K = .80		K = 1.0		K = 1.2	
In	mm		Lbs	kN	Lbs	kN	Lbs	kN	Lbs	kN	Lbs	kN
24	610	P3000	3040	13.5	8890	39.5	8800	39.1	8640	38.4	8440	37.5
		P3001	5660	25.2	21550	95.9	21310	94.8	20910	93.0	20410	90.8
36	914	P3000	2720	12.1	7520	33.5	7310	32.5	6930	30.8	6460	28.7
		P3001	5480	24.4	20960	93.2	20410	90.8	19510	86.8	18400	81.8
48	1219	P3000	2390	10.6	6390	28.4	5990	26.6	5310	23.6	4600	20.5
		P3001	5240	23.3	20130	89.5	19160	85.2	17550	78.1	15570	69.3
60	1524	P3000	2090	9.3	5430	24.2	4870	21.7	4130	18.4	3460	15.4
		P3001	4940	22.0	19070	84.8	17550	78.1	15020	66.8	11940	53.1
72	1829	P3000	1830	8.1	4680	20.8	4080	18.1	3340	14.9	2450	10.9
		P3001	4610	20.5	17770	79.0	15570	69.3	11940	53.1	8350	37.1
84	2134	P3000	1610	7.2	4110	18.3	3480	15.5	2600	11.6	**	**
		P3001	4230	18.8	16230	72.2	13240	58.9	8840	39.3	6140	27.3
96	2438	P3000	1420	6.3	3640	16.2	3000	13.3	1990	8.9	**	**
		P3001	3800	16.9	14450	64.3	10570	47.0	6770	30.1	4700	20.9
108	2743	P3000	1230	5.5	3240	14.4	2450	10.9	**	**	**	**
		P3001	3380	15.0	12440	55.3	8350	37.1	5350	23.8	**	**
120	3048	P3000	1070	4.8	2890	12.9	1990	8.9	**	**	**	**
		P3001	3020	13.4	10250	45.6	6770	30.1	4330	19.3	**	**

** $\frac{KL}{r} > 200$

ELEMENTS OF SECTION

Channel	Areas of Section		Axis 1 - 1						Axis 2 - 2					
			I		S		r		I		S		r	
	In ²	cm ²	In ⁴	cm ⁴	In ³	cm ³	In	cm	In ⁴	cm ⁴	In ³	cm ³	In	cm
P3000	.503	3.2	.121	5.0	.154	2.5	.490	1.2	.205	8.5	.253	4.1	.639	1.6
P3001	1.007	6.5	.593	24.7	.431	7.1	.767	1.9	.411	17.1	.506	8.3	.639	1.6

I - Moment of Inertia

S - Section Modulus

r - Radius of Gyration

P3300

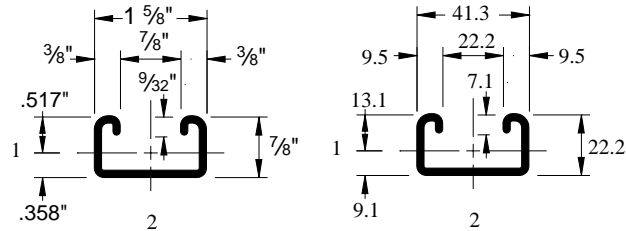
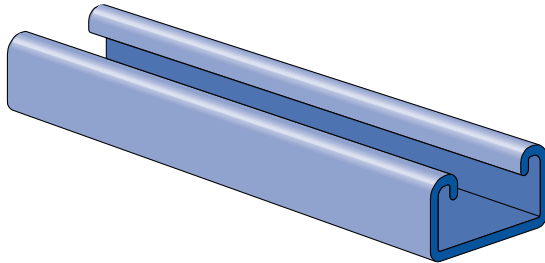

Pierced channels are found on pages 60 and 61.

Weight: 135 Lbs/C Ft (201 kg/100 m)

P3301

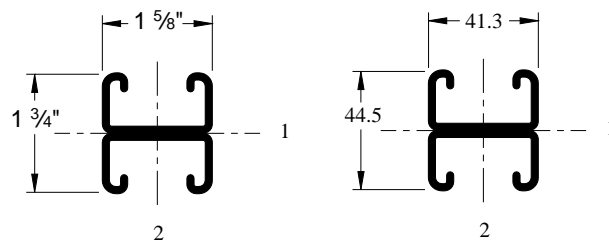
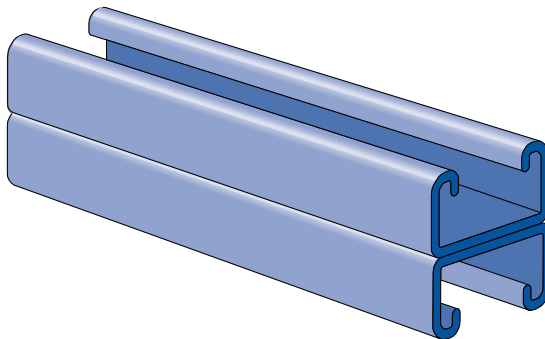

Weight: 270 Lbs/C Ft (402 kg/100 m)

BEAM LOAD*

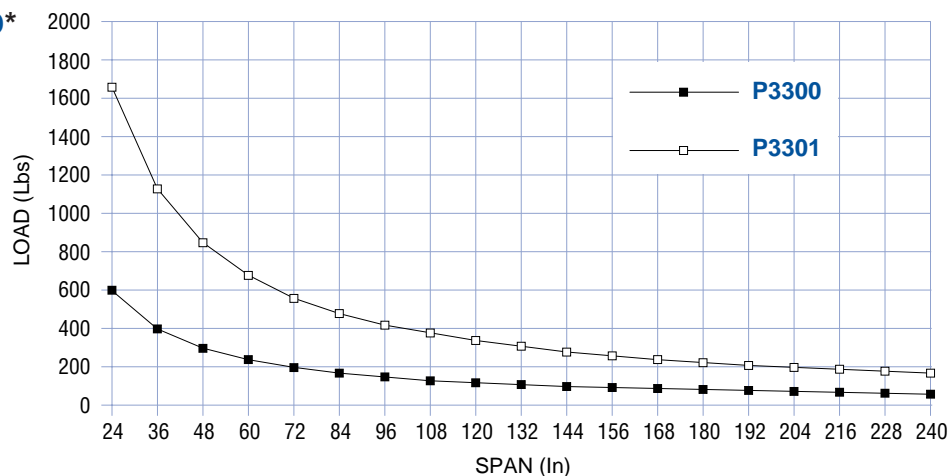

* Maximum allowable uniform load.

Channel	Weight		Allowable Moment		Material Thickness		Standard Lengths		Finishes				Other Materials	
	Lbs/Ft	kg/m	In-Lb	N*m	In	mm	10'	20'	PL	GR	HG	PG	SS	EA
P3300	1.35	2.0	1,810	200	.105	2.7	■	■	■	■	■	■	■	
P3301	2.70	4.0	5,080	570	.105	2.7	■	■	■	■	■	■	■	

Nominal thickness of 12 gage strip steel is .105 inches.



BEAM LOADING DATA

Span		Channel	Max. Allowable Uniform Load		Deflection at Uniform Load		Uniform Loading at Deflections					
							Span/180		Span/240		Span/360	
In	mm		Lbs	kN	In	mm	Lbs	kN	Lbs	kN	Lbs	kN
24	610	P3300	600	2.7	0.10	3	600	2.7	600	2.7	400	1.8
		P3301	1660*	7.4	0.06	1	1660*	7.4	1660*	7.4	1660*	7.4
36	914	P3300	400	1.8	0.22	6	360	1.6	270	1.2	180	0.8
		P3301	1130	5.0	0.13	3	1130	5.0	1130	5.0	860	3.8
48	1219	P3300	300	1.3	0.40	10	200	0.9	150	0.7	100	0.4
		P3301	850	3.8	0.23	6	850	3.8	730	3.2	480	2.1
60	1524	P3300	240	1.1	0.62	16	130	0.6	100	0.4	60	0.3
		P3301	680	3.0	0.37	9	620	2.8	460	2.0	310	1.4
72	1829	P3300	200	0.9	0.89	23	90	0.4	70	0.3	40	0.2
		P3301	560	2.5	0.52	13	430	1.9	320	1.4	210	0.9
84	2134	P3300	170	0.8	1.20	31	70	0.3	50	0.2	30	0.1
		P3301	480	2.1	0.71	18	320	1.4	240	1.1	160	0.7
96	2438	P3300	150	0.7	1.58	40	50	0.2	40	0.2	30	0.1
		P3301	420	1.9	0.93	24	240	1.1	180	0.8	120	0.5
108	2743	P3300	130	0.6	1.95	50	40	0.2	30	0.1	20	0.1
		P3301	380	1.7	1.19	30	190	0.8	140	0.6	100	0.4
120	3048	P3300	120	0.5	2.47	63	30	0.1	20	0.1	20	0.1
		P3301	340	1.5	1.47	37	150	0.7	120	0.5	80	0.4

*Load limited by spot weld shear.

Notes:

1. Above loads include the weight of the member. This weight must be deducted to arrive at the net allowable load the beam will support.
2. Long span beams should be supported in such a manner as to prevent rotation and twist.
3. Allowable uniformly distributed loads are listed for various simple spans, that is, a beam on two supports. If load is concentrated at the center of the span, multiply load from the table by 0.5 and corresponding deflection by 0.8.
4. Other lengths are also available on request.



COLUMN LOADING DATA

Unbraced Height		Channel	Max. Allowable Load at Slot Face		Maximum Column Load Applied at C.G.							
					K = .65		K = .80		K = 1.0		K = 1.2	
In	mm		Lbs	kN	Lbs	kN	Lbs	kN	Lbs	kN	Lbs	kN
24	610	P3300	2110	9.4	7100	31.6	7030	31.3	6770	30.1	5920	26.3
		P3301	4110	18.3	16740	74.5	16390	72.9	15800	70.3	15080	67.1
36	914	P3300	1790	8.0	6250	27.8	5920	26.3	4360	19.4	3030	13.5
		P3301	3820	17.0	15880	70.6	15080	67.1	13760	61.2	12150	54.0
48	1219	P3300	1400	6.2	5440	24.2	3830	17.0	2450	10.9	1700	7.6
		P3301	3470	15.4	14680	65.3	13260	59.0	10900	48.5	8080	35.9
60	1524	P3300	1080	4.8	3720	16.5	2450	10.9	1570	7.0	**	**
		P3301	3070	13.7	13120	58.4	10900	48.5	7450	33.1	5170	23.0
72	1829	P3300	860	3.8	2580	11.5	1700	7.6	**	**	**	**
		P3301	2640	11.7	11230	50.0	8080	35.9	5170	23.0	3590	16.0
84	2134	P3300	**	**	1900	8.5	**	**	**	**	**	**
		P3301	2250	10.0	8990	40.0	5940	26.4	3800	16.9	**	**
96	2438	P3300	**	**	**	**	**	**	**	**	**	**
		P3301	1930	8.6	6890	30.6	4550	20.2	**	**	**	**
108	2743	P3300	**	**	**	**	**	**	**	**	**	**
		P3301	1670	7.4	5440	24.2	3590	16.0	**	**	**	**
120	3048	P3300	**	**	**	**	**	**	**	**	**	**
		P3301	**	**	4410	19.6	**	**	**	**	**	**

** $\frac{KL}{r} > 200$

ELEMENTS OF SECTION

Channel	Areas of Section		Axis 1 - 1						Axis 2 - 2					
			I		S		r		I		S		r	
	In ²	cm ²	In ⁴	cm ⁴	In ³	cm ³	In	cm	In ⁴	cm ⁴	In ³	cm ³	In	cm
P3300	.398	2.6	.037	1.5	.072	1.2	.306	.78	.145	6.0	.178	2.9	.603	1.5
P3301	.797	5.1	.177	7.4	.202	3.3	.471	1.2	.289	12.0	.356	5.8	.603	1.5

I - Moment of Inertia

S - Section Modulus

r - Radius of Gyration



P4000

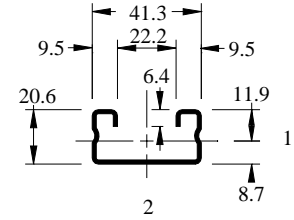
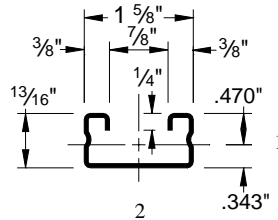
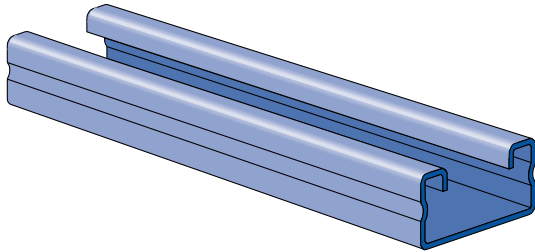

Pierced channels are found on pages 60 and 61.

Weight: 82 Lbs/C Ft (122 kg/100 m)

P4001

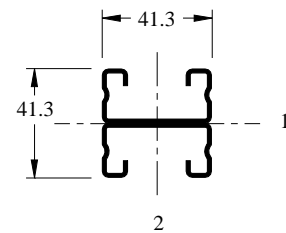
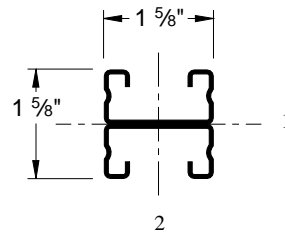
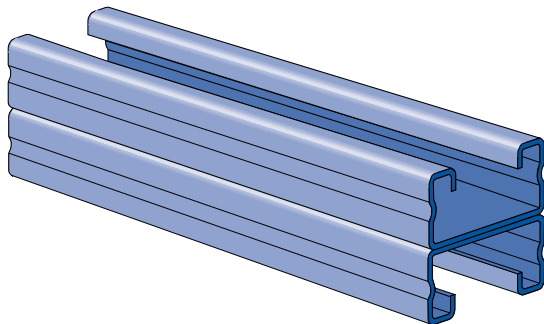

Weight: 164 Lbs/C Ft (244 kg/100 m)

BEAM LOAD*

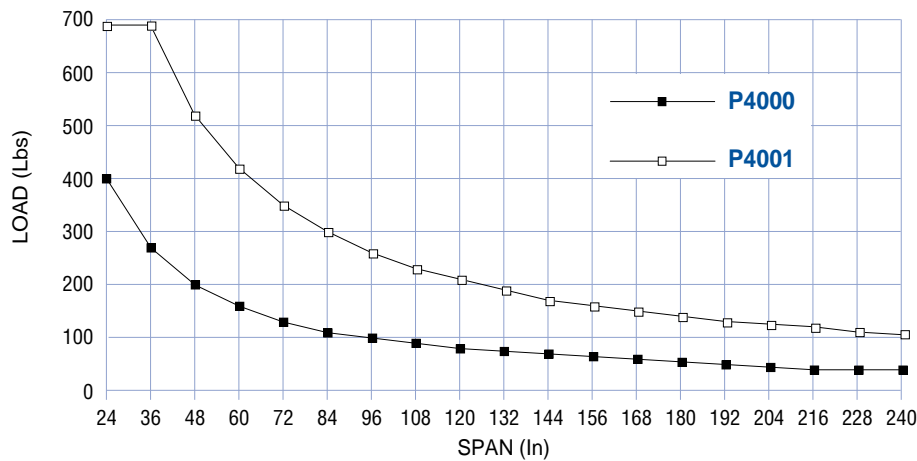

*Maximum allowable uniform load.

Channel	Weight		Allowable Moment		Material Thickness		Standard Lengths		Finishes				Other Materials	
	Lbs/Ft	kg/m	In-Lb	N*m	In	mm	10'	20'	PL	GR	HG	PG	SS	EA
P4000	0.82	1.2	1,210	140	.060	1.5	■	■	■	■	■	■	■	■
P4001	1.64	2.4	3,140	350	.060	1.5	■	■	■	■	■	■		■

Nominal thickness of 16 gage strip steel is .060 inches.



P4003

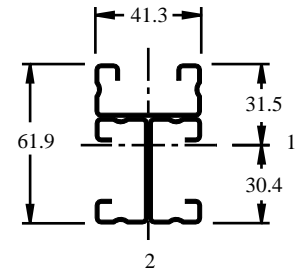
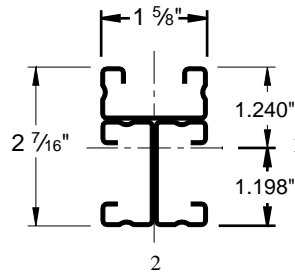
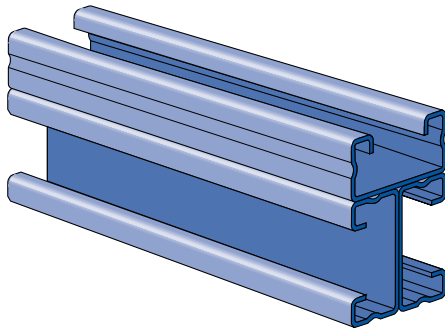

Weight: 246 Lbs/C Ft (366 kg/100 m)

P4004

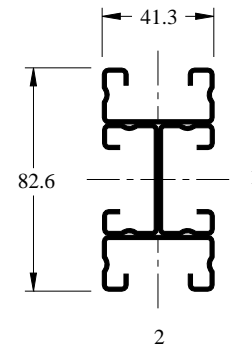
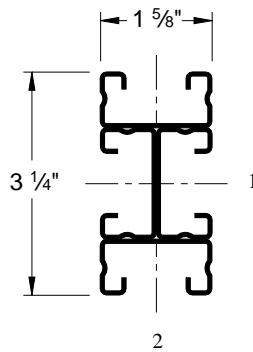
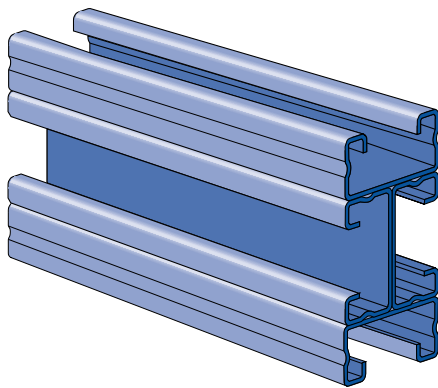

Weight: 328 Lbs/C Ft (488 kg/100 m)

Channel	Weight		Allowable Moment		Material Thickness		Standard Lengths		Finishes				Other Materials	
	Lbs/Ft	kg/m	In-Lb	N*m	In	mm	10'	20'	PL	GR	HG	PG	SS	EA
P4003	2.46	3.7	8,450	950	.060	1.5	■	■	■	■	■	■		
P4004	3.28	4.9	13,380	1,510	.060	1.5	■	■	■	■	■	■		



BEAM LOADING DATA

Span		Channel	Max. Allowable Uniform Load		Deflection at Uniform Load		Uniform Loading at Deflections					
							Span/180		Span/240		Span/360	
In	mm		Lbs	kN	In	mm	Lbs	kN	Lbs	kN	Lbs	kN
24	610	P4000	400	1.8	0.11	3	400	1.8	380	1.7	250	1.1
		P4001	690*	3.1	0.04	1	690*	3.1	690*	3.1	690*	3.1
36	914	P4000	270	1.2	0.24	6	220	1.0	170	0.8	110	0.5
		P4001	690*	3.1	0.14	4	690*	3.1	690*	3.1	490	2.2
48	1219	P4000	200	0.9	0.42	11	130	0.6	90	0.4	60	0.3
		P4001	520	2.3	0.25	6	520	2.3	410	1.8	280	1.2
60	1524	P4000	160	0.7	0.66	17	80	0.4	60	0.3	40	0.2
		P4001	420	1.9	0.40	10	350	1.6	260	1.2	180	0.8
72	1829	P4000	130	0.6	0.93	24	60	0.3	40	0.2	30	0.1
		P4001	350	1.6	0.57	15	250	1.1	180	0.8	120	0.5
84	2134	P4000	110	0.5	1.25	32	40	0.2	30	0.1	20	0.1
		P4001	300	1.3	0.78	20	180	0.8	140	0.6	90	0.4
96	2438	P4000	100	0.4	1.70	43	30	0.1	20	0.1	20	0.1
		P4001	260	1.2	1.01	26	140	0.6	100	0.4	70	0.3
108	2743	P4000	90	0.4	2.18	55	20	0.1	20	0.1	10	0.0
		P4001	230	1.0	1.27	32	110	0.5	80	0.4	50	0.2
120	3048	P4000	80	0.4	2.65	67	20	0.1	20	0.1	NR	NR
		P4001	210	0.9	1.59	40	90	0.4	70	0.3	40	0.2

*Load limited by spot weld shear.

NR = Not Recommended

Notes:

1. Above loads include the weight of the member. This weight must be deducted to arrive at the net allowable load the beam will support.
2. Long span beams should be supported in such a manner as to prevent rotation and twist.
3. Allowable uniformly distributed loads are listed for various simple spans, that is, a beam on two supports. If load is concentrated at the center of the span, multiply load from the table by 0.5 and corresponding deflection by 0.8.
4. Other lengths are also available on request.



COLUMN LOADING DATA

Unbraced Height		Channel	Max. Allowable Load at Slot Face		Maximum Column Load Applied at C.G.							
					K = .65		K = .80		K = 1.0		K = 1.2	
In	mm		Lbs	kN	Lbs	kN	Lbs	kN	Lbs	kN	Lbs	kN
24	610	P4000	1380	6.1	3720	16.5	3680	16.4	3610	16.1	3520	15.7
		P4001	2650	11.8	10020	44.6	9800	43.6	9430	41.9	8980	39.9
36	914	P4000	990	4.4	2010	8.9	1960	8.7	1880	8.4	1780	7.9
		P4001	2440	10.9	9480	42.2	8980	39.9	8150	36.3	7130	31.7
48	1219	P4000	690	3.1	1130	5.0	1100	4.9	1060	4.7	1000	4.4
		P4001	2200	9.8	8720	38.8	7830	34.8	6350	28.2	4620	20.6
60	1524	P4000	500	2.2	720	3.2	710	3.2	680	3.0	**	**
		P4001	1920	8.5	7750	34.5	6350	28.2	4260	18.9	2960	13.2
72	1829	P4000	380	1.7	500	2.2	490	2.2	**	**	**	**
		P4001	1630	7.3	6550	29.1	4620	20.6	2960	13.2	2050	9.1
84	2134	P4000	**	**	370	1.7	**	**	**	**	**	**
		P4001	1370	6.1	5140	22.9	3400	15.1	2170	9.7	**	**
96	2438	P4000	**	**	**	**	**	**	**	**	**	**
		P4001	1170	5.2	3940	17.5	2600	11.6	**	**	**	**
108	2743	P4000	**	**	**	**	**	**	**	**	**	**
		P4001	1010	4.5	3110	13.8	2050	9.1	**	**	**	**
120	3048	P4000	**	**	**	**	**	**	**	**	**	**
		P4001	**	**	2520	11.2	**	**	**	**	**	**

** $\frac{KL}{T} > 200$

ELEMENTS OF SECTION

Channel	Areas of Section		Axis 1 - 1						Axis 2 - 2					
			I		S		r		I		S		r	
	In ²	cm ²	In ⁴	cm ⁴	In ³	cm ³	In	cm	In ⁴	cm ⁴	In ³	cm ³	In	cm
P4000	.239	1.50	.023	0.96	.048	0.79	.308	0.78	.091	3.80	.112	1.80	.617	1.60
P4001	.478	3.10	.101	4.20	.125	2.00	.460	1.20	.182	7.60	.224	3.70	.617	1.60

I - Moment of Inertia

S - Section Modulus

r - Radius of Gyration



P4100

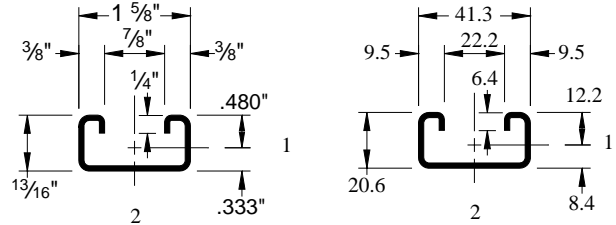
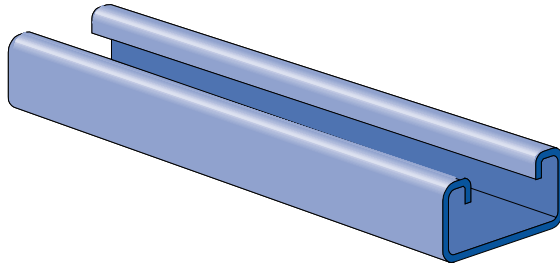

Pierced channels are found on pages 60 and 61.

Weight: 97 Lbs/C Ft (144 kg/100 m)

P4101

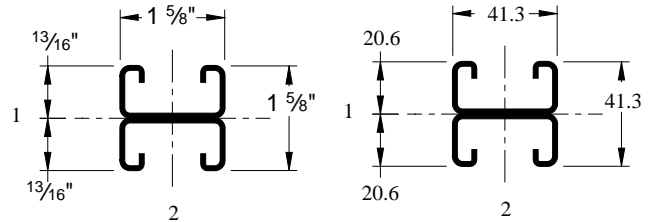
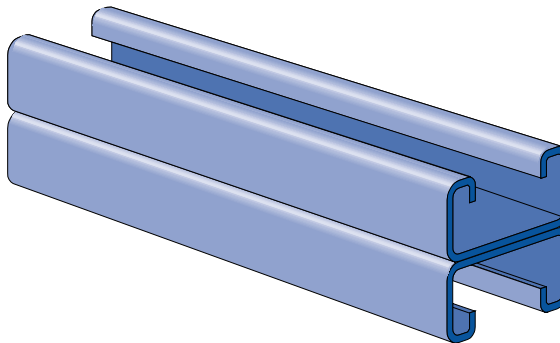

Weight: 194 Lbs/C Ft (289 kg/100 m)

BEAM LOAD*

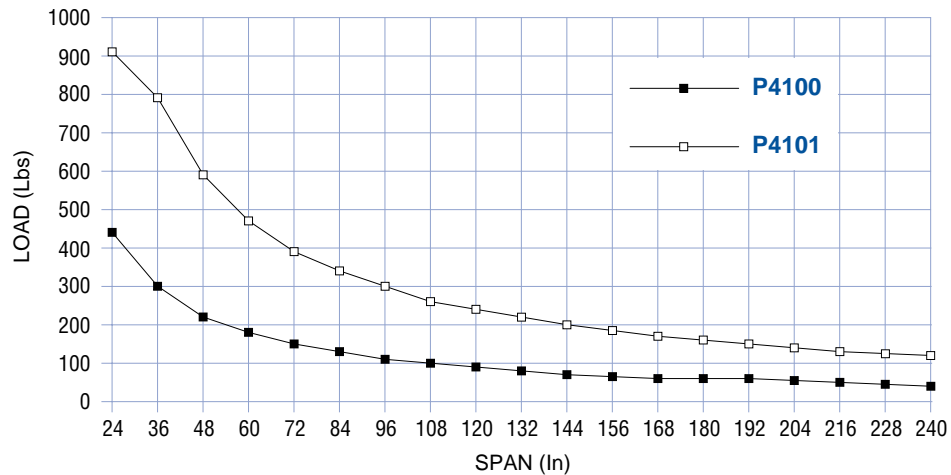

*Maximum allowable uniform load.

Channel	Weight		Allowable Moment		Material Thickness		Standard Lengths		Finishes				Other Materials	
	Lbs/Ft	kg/m	In-Lb	N*m	In	mm	10'	20'	PL	GR	HG	PG	SS	EA
P4100	.97	1.4	1,330	150	.075	1.9	■	■	■	■	■	■		
P4101	1.94	2.9	3,550	400	.075	1.9	■	■	■	■	■	■		

Nominal thickness of 14 gage strip steel is .075 inches.



BEAM LOADING DATA

Span		Channel	Max. Allowable Uniform Load		Deflection at Uniform Load		Uniform Loading at Deflections					
							Span/180		Span/240		Span/360	
In	mm		Lbs	kN	In	mm	Lbs	kN	Lbs	kN	Lbs	kN
24	610	P4100	440	2.0	0.11	3	440	2.0	410	1.8	270	1.2
		P4101	910*	4.0	0.05	1	910*	4.0	910*	4.0	910*	4.0
36	914	P4100	300	1.3	0.25	6	240	1.1	180	0.8	120	0.5
		P4101	790	3.5	0.14	4	790	3.5	790	3.5	550	2.4
48	1219	P4100	220	1.0	0.43	11	140	0.6	100	0.4	70	0.3
		P4101	590	2.6	0.25	6	590	2.6	470	2.1	310	1.4
60	1524	P4100	180	0.8	0.69	17	90	0.4	70	0.3	40	0.2
		P4101	470	2.1	0.39	10	400	1.8	300	1.3	200	0.9
72	1829	P4100	150	0.7	0.99	25	60	0.3	50	0.2	30	0.1
		P4101	390	1.7	0.56	14	280	1.2	210	0.9	140	0.6
84	2134	P4100	130	0.6	1.36	35	40	0.2	30	0.1	20	0.1
		P4101	340	1.5	0.78	20	200	0.9	150	0.7	100	0.4
96	2438	P4100	110	0.5	1.72	44	30	0.1	30	0.1	20	0.1
		P4101	300	1.3	1.03	26	160	0.7	120	0.5	80	0.4
108	2743	P4100	100	0.4	2.22	56	30	0.1	20	0.1	10	0.0
		P4101	260	1.2	1.27	32	120	0.5	90	0.4	60	0.3
120	3048	P4100	90	0.4	2.75	70	20	0.1	20	0.1	NR	NR
		P4101	240	1.1	1.61	41	100	0.4	70	0.3	50	0.2

*Load limited by spot weld shear.

NR = Not Recommended

Notes:

1. Above loads include the weight of the member. This weight must be deducted to arrive at the net allowable load the beam will support.
2. Long span beams should be supported in such a manner as to prevent rotation and twist.
3. Allowable uniformly distributed loads are listed for various simple spans, that is, a beam on two supports. If load is concentrated at the center of the span, multiply load from the table by 0.5 and corresponding deflection by 0.8.



COLUMN LOADING DATA

Unbraced Height		Channel	Max. Allowable Load at Slot Face		Maximum Column Load Applied at C.G.							
					K = .65		K = .80		K = 1.0		K = 1.2	
In	mm		Lbs	kN	Lbs	kN	Lbs	kN	Lbs	kN	Lbs	kN
24	610	P4100	1620	7.2	5320	23.7	5270	23.4	4810	21.4	4160	18.5
		P4101	3030	13.5	12000	53.4	11720	52.1	11250	50.0	10680	47.5
36	914	P4100	1340	6.0	4870	21.7	4160	18.5	2980	13.3	2070	9.2
		P4101	2790	12.4	11320	50.4	10680	47.5	9620	42.8	8330	37.1
48	1219	P4100	1020	4.5	3800	16.9	2620	11.7	1680	7.5	1160	5.2
		P4101	2500	11.1	10350	46.0	9210	41.0	7330	32.6	5240	23.3
60	1524	P4100	780	3.5	2540	11.3	1680	7.5	**	**	**	**
		P4101	2180	9.7	9110	40.5	7330	32.6	4830	21.5	3350	14.9
72	1829	P4100	610	2.7	1760	7.8	1160	5.2	**	**	**	**
		P4101	1840	8.2	7590	33.8	5240	23.3	3350	14.9	2330	10.4
84	2134	P4100	**	**	1300	5.8	**	**	**	**	**	**
		P4101	1550	6.9	5830	25.9	3850	17.1	2460	10.9	**	**
96	2438	P4100	**	**	**	**	**	**	**	**	**	**
		P4101	1320	5.9	4470	19.9	2950	13.1	**	**	**	**
108	2743	P4100	**	**	**	**	**	**	**	**	**	**
		P4101	1140	5.1	3530	15.7	2330	10.4	**	**	**	**
120	3048	P4100	**	**	**	**	**	**	**	**	**	**
		P4101	**	**	2860	12.7	**	**	**	**	**	**

** $\frac{KL}{r} > 200$

ELEMENTS OF SECTION

Channel	Areas of Section		Axis 1 - 1						Axis 2 - 2					
			I		S		r		I		S		r	
	In ²	cm ²	In ⁴	cm ⁴	In ³	cm ³	In	cm	In ⁴	cm ⁴	In ³	cm ³	In	cm
P4100	.287	1.9	.025	1.0	.053	.87	.298	.76	.106	4.4	.131	2.1	.609	1.5
P4101	.574	3.7	.114	4.7	.141	2.3	.447	1.1	.212	8.8	.261	4.3	.609	1.5

I - Moment of Inertia

S - Section Modulus

r - Radius of Gyration



P5000

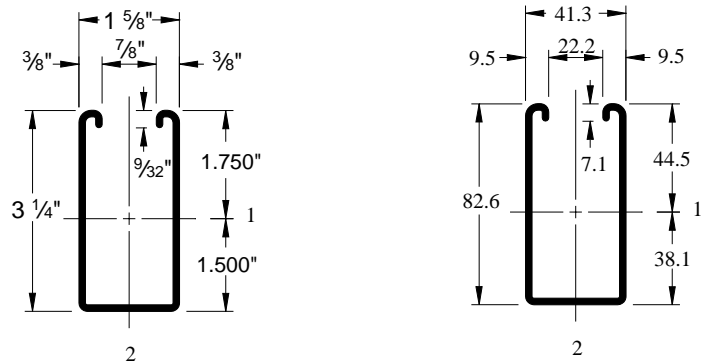
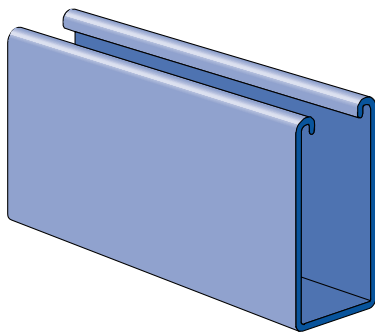

Pierced channels are found on pages 60 and 61.

Weight: 305 Lbs/C Ft (454 kg/100 m)

P5001

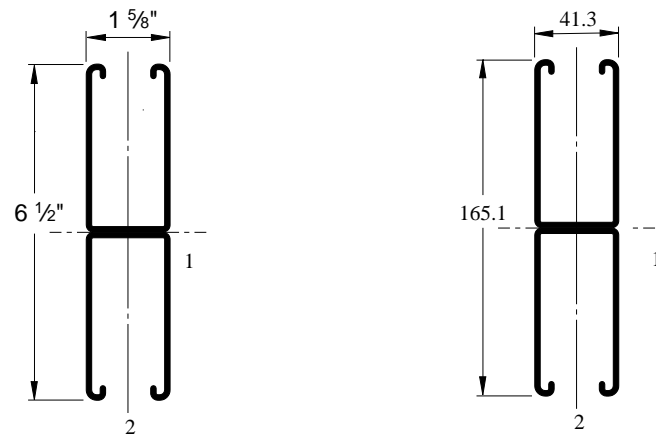
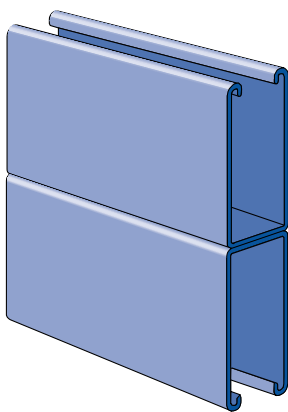

Weight: 610 Lbs/C Ft (908 kg/100 m)

BEAM LOAD*

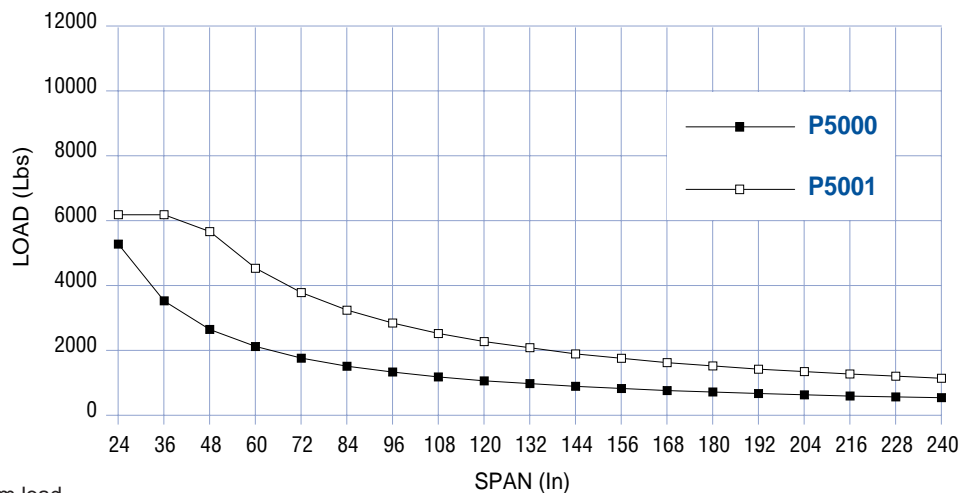

*Maximum allowable uniform load.

Channel	Weight		Allowable Moment		Material Thickness		Standard Lengths		Finishes				Other Materials	
	Lbs/Ft	kg/m	In-Lb	N*m	In	mm	10'	20'	PL	GR	HG	PG	SS	EA
P5000	3.05	4.5	15,790	1,780	.105	2.7	■	■	■	■	■	■		
P5001	6.10	9.1	33,910	3,830	.105	2.7	■	■	■	■	■	■		

Nominal thickness of 12 gage strip steel is .105 inches.



BEAM LOADING DATA

Span		Channel	Max. Allowable Uniform Load		Deflection at Uniform Load		Uniform Loading at Deflections					
							Span/180		Span/240		Span/360	
In	mm		Lbs	kN	In	mm	Lbs	kN	Lbs	kN	Lbs	kN
24	610	P5000	5260†	23.4	0.03	1	5260	23.4	5260	23.4	5260	23.4
		P5001	6170*†	27.4	0.01	0	6170*†	27.4	6170*†	27.4	6170*†	27.4
36	914	P5000	3510	15.6	0.07	2	3510	15.6	3510	15.6	3510	15.6
		P5001	6170*†	27.4	0.02	1	6170*†	27.4	6170*†	27.4	6170*†	27.4
48	1219	P5000	2630	11.7	0.12	3	2630	11.7	2630	11.7	2630	11.7
		P5001	5650†	25.1	0.05	1	5650†	25.1	5650†	25.1	5650†	25.1
60	1524	P5000	2110	9.4	0.18	5	2110	9.4	2110	9.4	1920	8.5
		P5001	4520†	20.1	0.08	2	4520†	20.1	4520†	20.1	4520†	20.1
72	1829	P5000	1750	7.8	0.26	7	1750	7.8	1750	7.8	1330	5.9
		P5001	3770	16.8	0.11	3	3770	16.8	3770	16.8	3770	16.8
84	2134	P5000	1500	6.7	0.36	9	1500	6.7	1470	6.5	980	4.4
		P5001	3230	14.4	0.15	4	3230	14.4	3230	14.4	3230	14.4
96	2438	P5000	1320	5.9	0.47	12	1320	5.9	1130	5.0	750	3.3
		P5001	2830	12.6	0.20	5	2830	12.6	2830	12.6	2830	12.6
108	2743	P5000	1170	5.2	0.59	15	1170	5.2	890	4.0	590	2.6
		P5001	2510	11.2	0.25	6	2510	11.2	2510	11.2	2510	11.2
120	3048	P5000	1050	4.7	0.73	19	960	4.3	720	3.2	480	2.1
		P5001	2260	10.1	0.31	8	2260	10.1	2260	10.1	2260	10.1
144	3658	P5000	880	3.9	1.06	27	670	3.0	500	2.2	330	1.5
		P5001	1880	8.4	0.44	11	1880	8.4	1880	8.4	1690	7.5
168	4267	P5000	750	3.3	1.43	36	490	2.2	370	1.6	250	1.1
		P5001	1610	7.2	0.60	15	1610	7.2	1610	7.2	1240	5.5
192	4877	P5000	660	2.9	1.88	48	380	1.7	280	1.2	190	0.8
		P5001	1410	6.3	0.79	20	1410	6.3	1410	6.3	950	4.2
216	5486	P5000	580	2.6	2.35	60	300	1.3	220	1.0	150	0.7
		P5001	1260	5.6	1.00	26	1260	5.6	1130	5.0	750	3.3
240	6096	P5000	530	2.4	2.94	75	240	1.1	180	0.8	120	0.5
		P5001	1130	5.0	1.24	31	1130	5.0	910	4.0	610	2.7

*Load limited by spot weld shear. †Bearing load may govern capacity. See page 67.

Notes:

1. Above loads include the weight of the member. This weight must be deducted to arrive at the net allowable load the beam will support.
2. Long span beams should be supported in such a manner as to prevent rotation and twist.
3. Allowable uniformly distributed loads are listed for various simple spans, that is, a beam on two supports. If load is concentrated at the center of the span, multiply load from the table by 0.5 and corresponding deflection by 0.8.



COLUMN LOADING DATA

Unbraced Height		Channel	Max. Allowable Load at Slot Face		Maximum Column Load Applied at C.G.							
					K = .65		K = .80		K = 1.0		K = 1.2	
In	mm		Lbs	kN	Lbs	kN	Lbs	kN	Lbs	kN	Lbs	kN
24	610	P5000	5120	22.8	12130	54.0	12030	53.5	11870	52.8	11660	51.9
		P5001	7730	34.4	30390	135.2	30170	134.2	29790	132.5	29330	130.5
36	914	P5000	4310	19.2	8650	38.5	8430	37.5	8050	35.8	7590	33.8
		P5001	7650	34.0	29840	132.7	29330	130.5	28490	126.7	27460	122.1
48	1219	P5000	3310	14.7	5520	24.6	5320	23.7	5020	22.3	4690	20.9
		P5001	7540	33.5	29070	129.3	28170	125.3	26670	118.6	24830	110.4
60	1524	P5000	2660	11.8	4000	17.8	3840	17.1	3590	16.0	3330	14.8
		P5001	7390	32.9	28080	124.9	26670	118.6	24320	108.2	21460	95.5
72	1829	P5000	2240	10.0	3160	14.1	3020	13.4	2800	12.5	2570	11.4
		P5001	7200	32.0	26870	119.5	24830	110.4	21460	95.5	17330	77.1
84	2134	P5000	1940	8.6	2650	11.8	2510	11.2	2310	10.3	2100	9.3
		P5001	6960	31.0	25440	113.2	22670	100.8	18070	80.4	12930	57.5
96	2438	P5000	1730	7.7	2310	10.3	2170	9.7	1980	8.8	1780	7.9
		P5001	6660	29.6	23790	105.8	20170	89.7	14260	63.4	9900	44.0
108	2743	P5000	1570	7.0	2070	9.2	1930	8.6	1730	7.7	1540	6.9
		P5001	6280	27.9	21920	97.5	17330	77.1	11270	50.1	7820	34.8
120	3048	P5000	1440	6.4	1880	8.4	1740	7.7	1550	6.9	**	**
		P5001	5800	25.8	19830	88.2	14260	63.4	9130	40.6	**	**

** $\frac{KL}{r} > 200$

ELEMENTS OF SECTION

Channel	Areas of Section		Axis 1 - 1						Axis 2 - 2					
			I		S		r		I		S		r	
	In ²	cm ²	In ⁴	cm ⁴	In ³	cm ³	In	cm	In ⁴	cm ⁴	In ³	cm ³	In	cm
P5000	.897	5.8	1.099	45.7	.628	10.3	1.107	2.8	.359*	14.9	.442*	7.2	.695	1.8
P5001	1.794	11.6	5.578*	232.2	1.716*	28.1	1.864	4.7	.719*	29.9	.884*	14.5	.695	1.8

I - Moment of Inertia

S - Section Modulus

r - Radius of Gyration

P5500

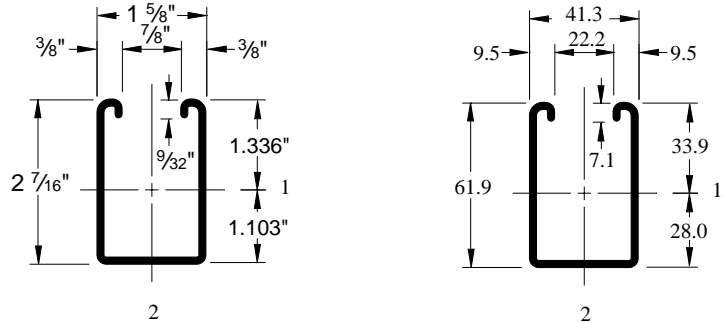
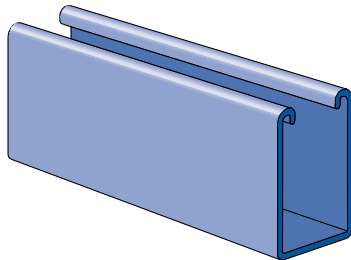

Pierced channels are found on pages 60 and 61.

Weight: 247 Lbs/C Ft (368 kg/100 m)

P5501

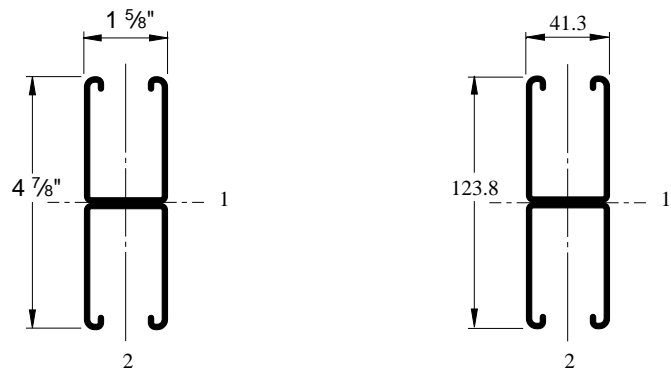
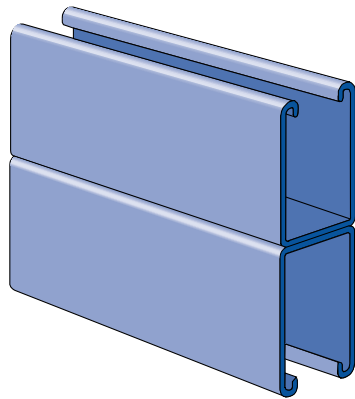

Weight: 494 Lbs/C Ft (735 kg/100 m)

BEAM LOAD*

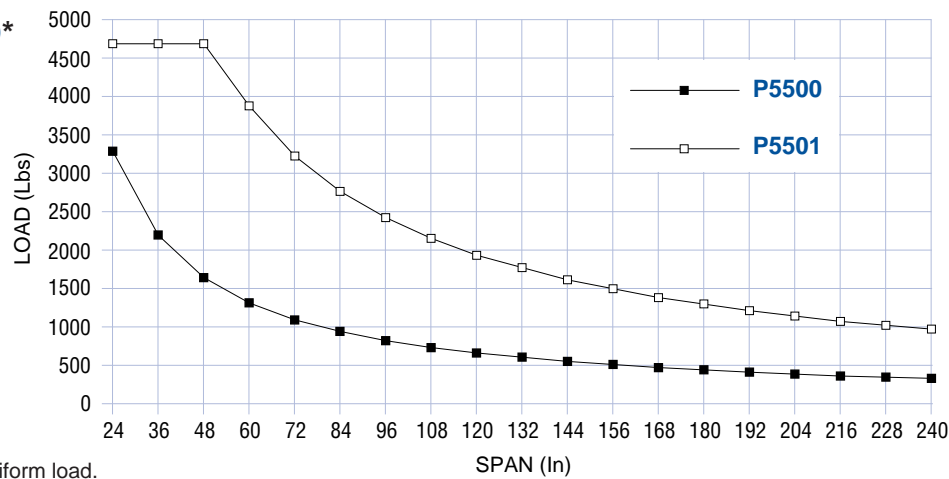

*Maximum allowable uniform load.

Channel	Weight		Allowable Moment		Material Thickness		Standard Lengths		Finishes				Other Materials	
	Lbs/Ft	kg/m	In-Lb	N•m	In	mm	10'	20'	PL	GR	HG	PG	SS	EA
P5500	2.47	3.7	9,830	1110	.105	2.5	■	■	■	■	■	■		■
P5501	4.94	7.4	29,000	3280	.105	2.5	■	■	■	■	■	■		

Nominal thickness of 12 gage strip steel is .105 inches.



BEAM LOADING DATA

Span		Channel	Max. Allowable Uniform Load		Deflection at Uniform Load		Uniform Loading at Deflections					
							Span/180		Span/240		Span/360	
In	mm		Lbs	kN	In	mm	Lbs	kN	Lbs	kN	Lbs	kN
24	610	P5500	3280	14.6	0.04	1	3280	14.6	3280	14.6	3280	14.6
		P5501	4680*	20.8	0.01	0	4680*	20.8	4680*	20.8	4680*	20.8
36	914	P5500	2190	9.7	0.09	2	2190	9.7	2190	9.7	2190	9.7
		P5501	4680*	20.8	0.03	1	4680*	20.8	4680*	20.8	4680*	20.8
48	1219	P5500	1640	7.3	0.15	4	1640	7.3	1640	7.3	1430	6.4
		P5501	4680*	20.8	0.08	2	4680*	20.8	4680*	20.8	4680*	20.8
60	1524	P5500	1310	5.8	0.24	6	1310	5.8	1310	5.8	910	4.0
		P5501	3870	17.2	0.13	3	3870	17.2	3870	17.2	3870	17.2
72	1829	P5500	1090	4.8	0.34	9	1090	4.8	950	4.2	630	2.8
		P5501	3220	14.3	0.19	5	3220	14.3	3220	14.3	3220	14.3
84	2134	P5500	940	4.2	0.47	12	930	4.1	700	3.1	470	2.1
		P5501	2760	12.3	0.26	7	2760	12.3	2760	12.3	2510	11.2
96	2438	P5500	820	3.6	0.61	16	710	3.2	540	2.4	360	1.6
		P5501	2420	10.8	0.34	9	2420	10.8	2420	10.8	1920	8.5
108	2743	P5500	730	3.2	0.78	20	560	2.5	420	1.9	280	1.2
		P5501	2150	9.6	0.43	11	2150	9.6	2150	9.6	1520	6.8
120	3048	P5500	660	2.9	0.96	24	460	2.0	340	1.5	230	1.0
		P5501	1930	8.6	0.52	13	1930	8.6	1840	8.2	1230	5.5
144	3658	P5500	550	2.4	1.39	35	320	1.4	240	1.1	160	0.7
		P5501	1610	7.2	0.75	19	1610	7.2	1280	5.7	850	3.8
168	4267	P5500	470	2.1	1.88	48	230	1.0	170	0.8	120	0.5
		P5501	1380	6.1	1.03	26	1250	5.6	940	4.2	630	2.8
192	4877	P5500	410	1.8	2.45	62	180	0.8	130	0.6	90	0.4
		P5501	1210	5.4	1.34	34	960	4.3	720	3.2	480	2.1
216	5486	P5500	360	1.6	3.06	78	140	0.6	110	0.5	70	0.3
		P5501	1070	4.8	1.69	43	760	3.4	570	2.5	380	1.7
240	6096	P5500	330	1.5	3.85	98	110	0.5	90	0.4	60	0.3
		P5501	970	4.3	2.11	53	610	2.7	460	2.0	310	1.4

*Load limited by spot weld shear.

Notes:

1. Above loads include the weight of the member. This weight must be deducted to arrive at the net allowable load the beam will support.
2. Long span beams should be supported in such a manner as to prevent rotation and twist.
3. Allowable uniformly distributed loads are listed for various simple spans, that is, a beam on two supports. If load is concentrated at the center of the span, multiply load from the table by 0.5 and corresponding deflection by 0.8.



COLUMN LOADING DATA

Unbraced Height		Channel	Max. Allowable Load at Slot Face		Maximum Column Load Applied at C.G.							
					K = .65		K = .80		K = 1.0		K = 1.2	
In	mm		Lbs	kN	Lbs	kN	Lbs	kN	Lbs	kN	Lbs	kN
24	610	P5500	4490	20.0	12060	53.6	11930	53.1	11710	52.1	11430	50.8
		P5501	8540	38.0	31180	138.7	30870	137.3	30350	135.0	29720	132.2
36	914	P5500	3810	16.9	8560	38.1	8260	36.7	7760	34.5	7200	32.0
		P5501	8390	37.3	30420	135.3	29720	132.2	28560	127.0	27140	120.7
48	1219	P5500	3080	13.7	5810	25.8	5540	24.6	5130	22.8	4700	20.9
		P5501	8190	36.4	29360	130.6	28120	125.1	26060	115.9	23540	104.7
60	1524	P5500	2610	11.6	4480	19.9	4230	18.8	3860	17.2	3480	15.5
		P5501	7920	35.2	28000	124.6	26060	115.9	22830	101.6	18900	84.1
72	1829	P5500	2290	10.2	3730	16.6	3480	15.5	3120	13.9	2760	12.3
		P5501	7590	33.8	26340	117.2	23540	104.7	18900	84.1	13610	60.5
84	2134	P5500	2050	9.1	3250	14.5	2990	13.3	2630	11.7	2290	10.2
		P5501	7160	31.8	24370	108.4	20560	91.5	14400	64.1	10000	44.5
96	2438	P5500	1860	8.3	2910	12.9	2640	11.7	2270	10.1	1940	8.6
		P5501	6620	29.4	22100	98.3	17120	76.2	11020	49.0	7650	34.0
108	2743	P5500	1710	7.6	2640	11.7	2360	10.5	2000	8.9	1680	7.5
		P5501	5970	26.6	19530	86.9	13610	60.5	8710	38.7	6050	26.9
120	3048	P5500	1580	7.0	2430	10.8	2140	9.5	1770	7.9	**	**
		P5501	5380	23.9	16660	74.1	11020	49.0	7050	31.4	**	**

** $\frac{KL}{r} > 200$

ELEMENTS OF SECTION

Channel	Areas of Section		Axis 1 - 1						Axis 2 - 2					
			I		S		r		I		S		r	
	In ²	cm ²	In ⁴	cm ⁴	In ³	cm ³	In	cm	In ⁴	cm ⁴	In ³	cm ³	In	cm
P5500	.726	4.7	.523	21.8	.391	6.4	.848	2.2	.335	13.9	.412	6.8	.679	1.7
P5501	1.453	9.4	2.811	117.0	1.153	18.9	1.391	3.5	.669	27.8	.824	13.5	.679	1.7

I - Moment of Inertia

S - Section Modulus

r - Radius of Gyration

P1184

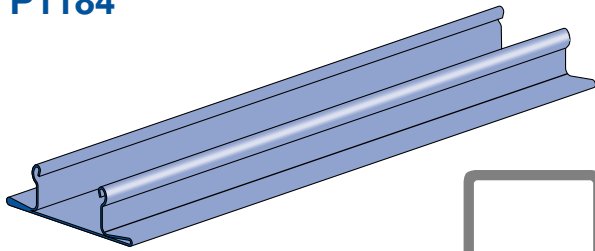

Standard Length: 10'.

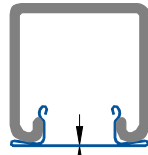

.020"
(0.5)

1 5/8"
(41.3)

Finish: Zinc bonderized, plain.

Weight: 27 Lbs/C Ft (40.2 kg/100 m)

P1184 PVC

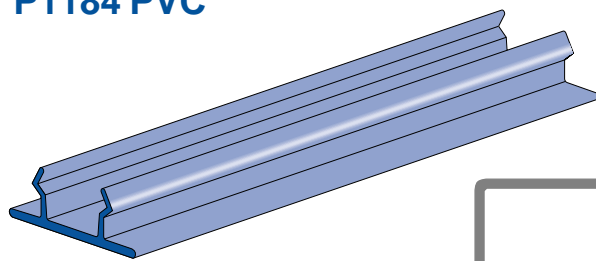

Standard Length: 10'.

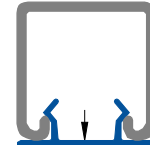

.085"
(2.2)

1 5/8"
(41.3)

Material: Paintable PVC.
Color: Green, Grey.

Weight: 11 Lbs/C Ft (16.5 kg/100 m)

P3184

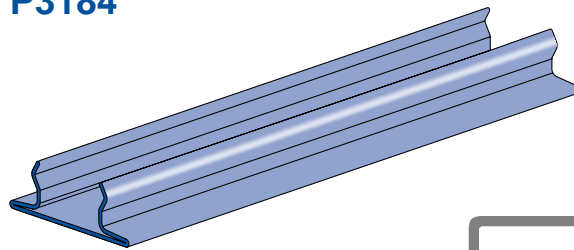

Standard Length: 10'.

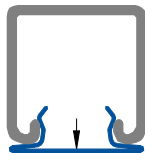

.040"
(1.0)

1 5/8"
(41.3)



Finish: Green, pre-galvanized, plain.

Weight: 47 Lbs/C Ft (69.9 kg/100 m)

P3184 P

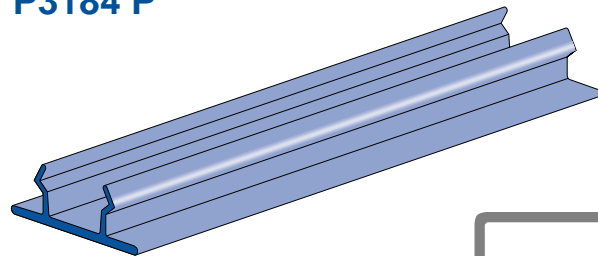

Standard Length: 10'.

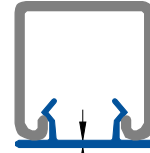

.085"
(2.2)

1 5/8"
(41.3)



Material : G.E. Noryl® Plastic.
Color: Green, Grey.

Weight: 9.4 Lbs/C Ft (14.0 kg/100 m)

P3184 F

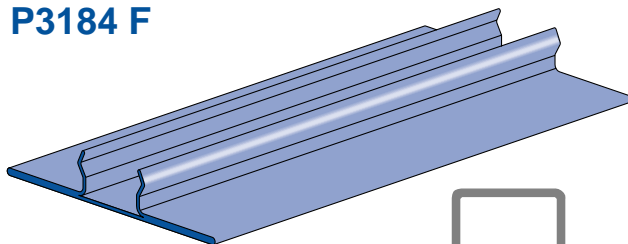

Standard Length: 16'.

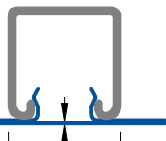

.040"
(1.0)

1 5/8"
(41.3)

3"
(76.2)

Finish: Green, pre-galvanized, plain.

Weight: 90 Lbs/C Ft (134 kg/100 m)

P3712 P

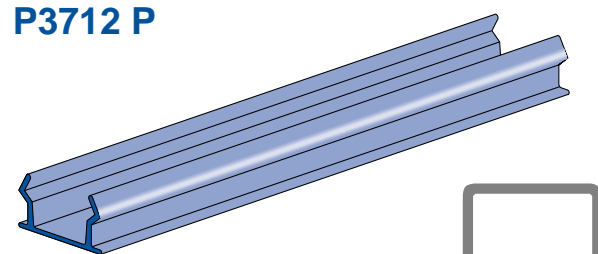

Standard Length: 10'.

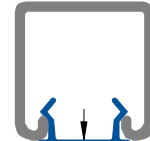

.040"
(1.0)

1 1/16"
(27.0)

Material: Plastic.
Color: Black.

Note: Use with P3170, P3270, and P3370 series concrete insert.

Weight: 5.4 Lbs/C Ft (8.0 kg/100 m)

P1000 DS

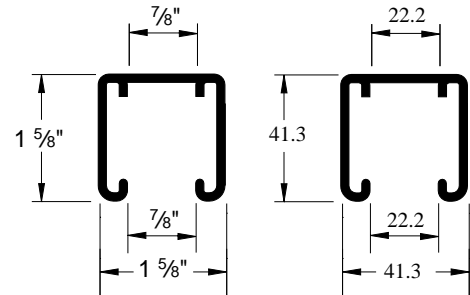
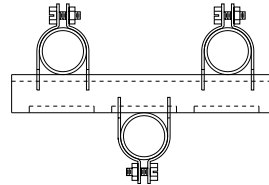
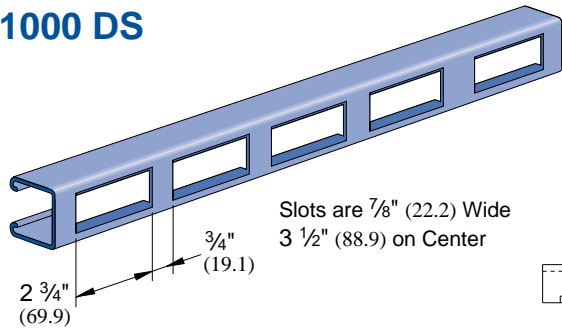

Standard Lengths: 10' and 20'.

Note: For beam load capacity, use 70% of P1000 load chart.

Weight: 173 Lbs/C Ft (257 kg/100m)

"T" SERIES

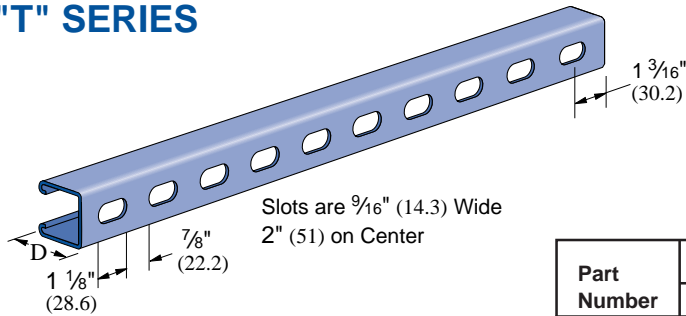

Part Number	Depth "D"		Material Thickness		Weight	
	In	mm	In	mm	Lbs/C Ft	kg/100m
P1000 T	1 5/8	41	.105	2.7	185	275
P1100 T	1 5/8	41	.075	1.6	136	202
P2000 T	1 5/8	41	.060	1.5	113	168
P3000 T	1 3/8	35	.105	2.7	165	245
P3300 T	7/8	22	.105	2.7	130	193
P4000 T	1 3/16	21	.060	1.5	79	118
P4100 T	1 3/16	21	.075	1.6	87	129
P5000 T	3/4	82	.105	2.7	300	446
P5500 T	2 7/16	62	.105	2.7	242	360

Standard Lengths: 10' and 20'.

Note: For beam load capacity, use 85% of appropriate load chart.

"KO" SERIES

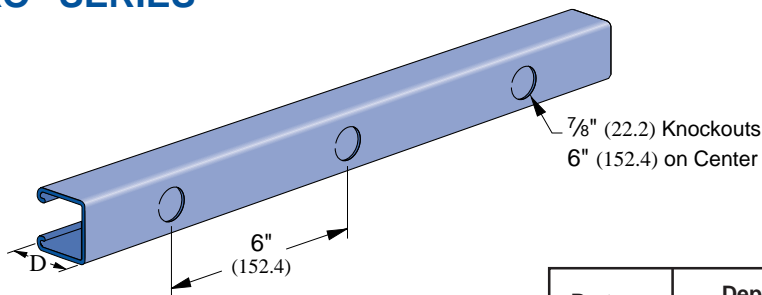

Part Number	Depth "D"		Material Thickness		Weight	
	In	mm	In	mm	Lbs/C Ft	kg/100m
P1000 KO	1 5/8	41	.105	2.7	190	283
P1100 KO	1 5/8	41	.075	1.9	140	208
P2000 KO	1 5/8	41	.060	1.5	117	174
P3000 KO	1 5/8	35	.105	2.7	170	253
P5000 KO	3/4	82	.105	2.7	305	454
P5500 KO	2 7/16	62	.105	2.7	247	368

Standard Lengths: 10' and 20'.

Note: For beam load capacity, use 95% of appropriate load chart.

P1000 H3

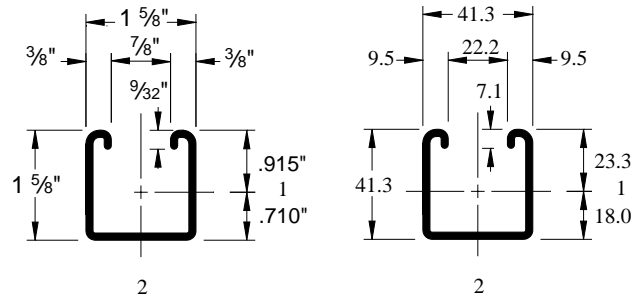
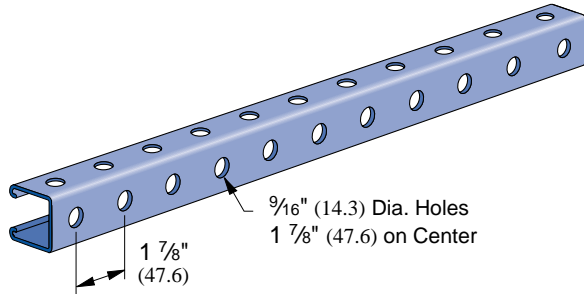

Standard Lengths: 10' and 20'.

Note: For beam load capacity, use 90% of P1000 load chart. For column load capacity, use 68% of P1000 load chart.

Weight: 175 Lbs/C Ft (260 kg/100 m)

"SL" SERIES

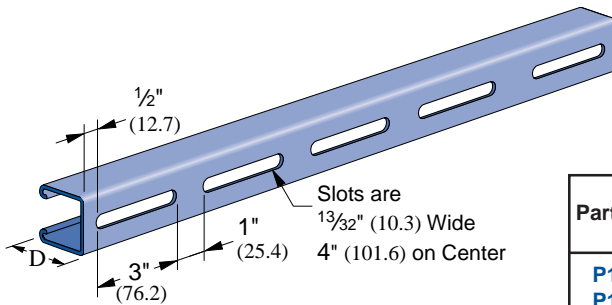

Part Number	Depth "D"		Material Thickness		Weight	
	In	mm	In	mm	Lbs/C Ft	kg/100 m
P1000 SL	1 ⁵ / ₈	41	.105	2.7	185	275
P1100 SL	1 ⁵ / ₈	41	.075	1.9	136	202
P2000 SL	1 ⁵ / ₈	41	.060	1.5	113	168
P3000 SL	1 ³ / ₈	35	.105	2.7	165	246
P3300 SL	7/8	22	.105	2.7	130	193
P4000 SL	1 ³ / ₁₆	21	.060	1.5	79	118
P4100 SL	1 ³ / ₁₆	21	.075	1.9	87	129
P5000 SL	3/4	82	.105	2.7	300	446
P5500 SL	2 ⁷ / ₁₆	62	.105	2.7	242	360

Standard Lengths: 10' and 20'.

Note: For beam load capacity, use 85% of appropriate load chart.

"HS" SERIES

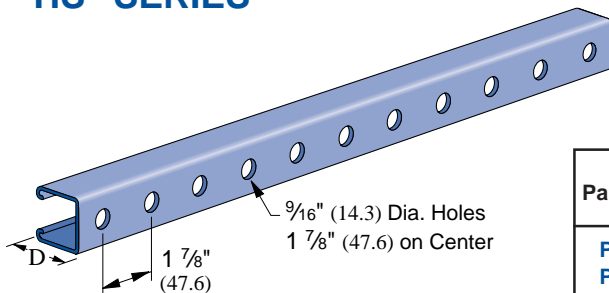

Part Number	Depth "D"		Material Thickness		Weight	
	In	mm	In	mm	Lbs/C Ft	kg/100 m
P1000 HS	1 ⁵ / ₈	41	.105	2.7	185	275
P1100 HS	1 ⁵ / ₈	41	.075	1.9	136	202
P2000 HS	1 ⁵ / ₈	41	.060	1.5	113	168
P3000 HS	1- ³ / ₈	35	.105	2.7	165	246
P3300 HS	7/8	22	.105	2.7	130	193
P4000 HS	1 ³ / ₁₆	21	.060	1.5	79	118
P4100 HS	1 ³ / ₁₆	21	.075	1.9	87	129
P5000 HS	3/4	82	.105	2.7	300	446
P5500 HS	2 ⁷ / ₁₆	62	.105	2.7	242	360

Standard Lengths: 10' and 20'.

Note: For beam load capacity, use 90% of appropriate load chart.

P9000

TELESTRUT TUBING

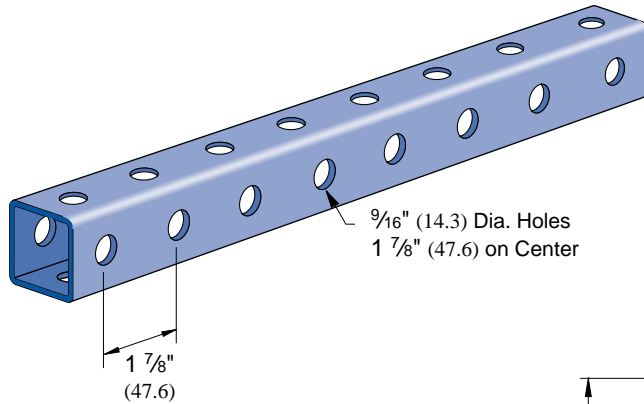

PATENT PENDING

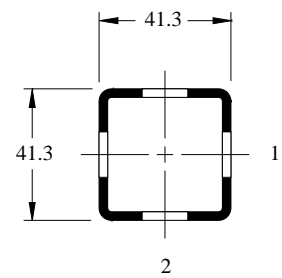
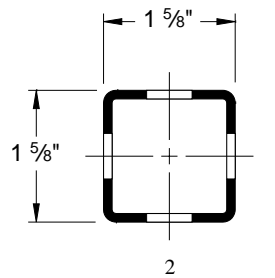

Note: Can be used with 1 5/8" (41mm) fittings.

Weight: 205 Lbs/C Ft (305 kg/100 m)

P9200

TELESTRUT TUBING

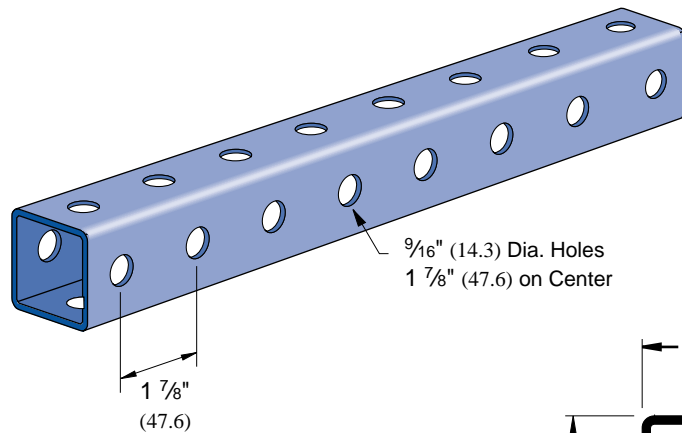

PATENT PENDING

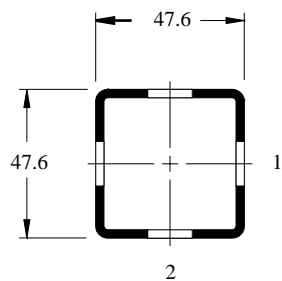
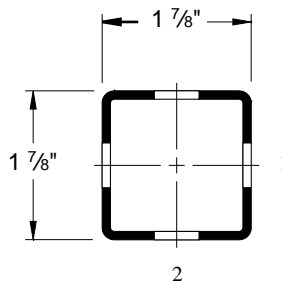

Note: Allows telescoping of P9000 and all 1 5/8" (41mm) Unistrut channels.

Weight: 223 Lbs/C Ft (332 kg/100 m)

Telestrut	Weight		Allowable Moment		Material Thickness		Standard Lengths		Finishes				Other Materials	
	Lbs/Ft	kg/m	In-Lb	N*m	In	mm	10'	20'	PL	GR	HG	PG	SS	EA
P9000	2.05	3.1	5,060	570	.105	2.5	■	■	■	■		■		
P9200	2.23	3.3	7,470	840	.105	2.5	■	■	■	■		■		

Nominal thickness of 12 gage strip steel is .105 inches.

TELESTRUT TUBING

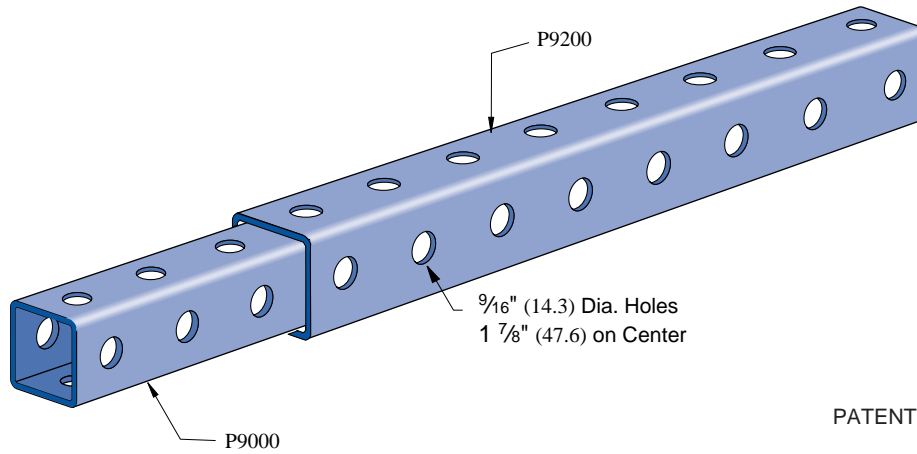

PATENT PENDING

Note: See Hardware section for rivets and gravity pins.

BEAM LOAD*

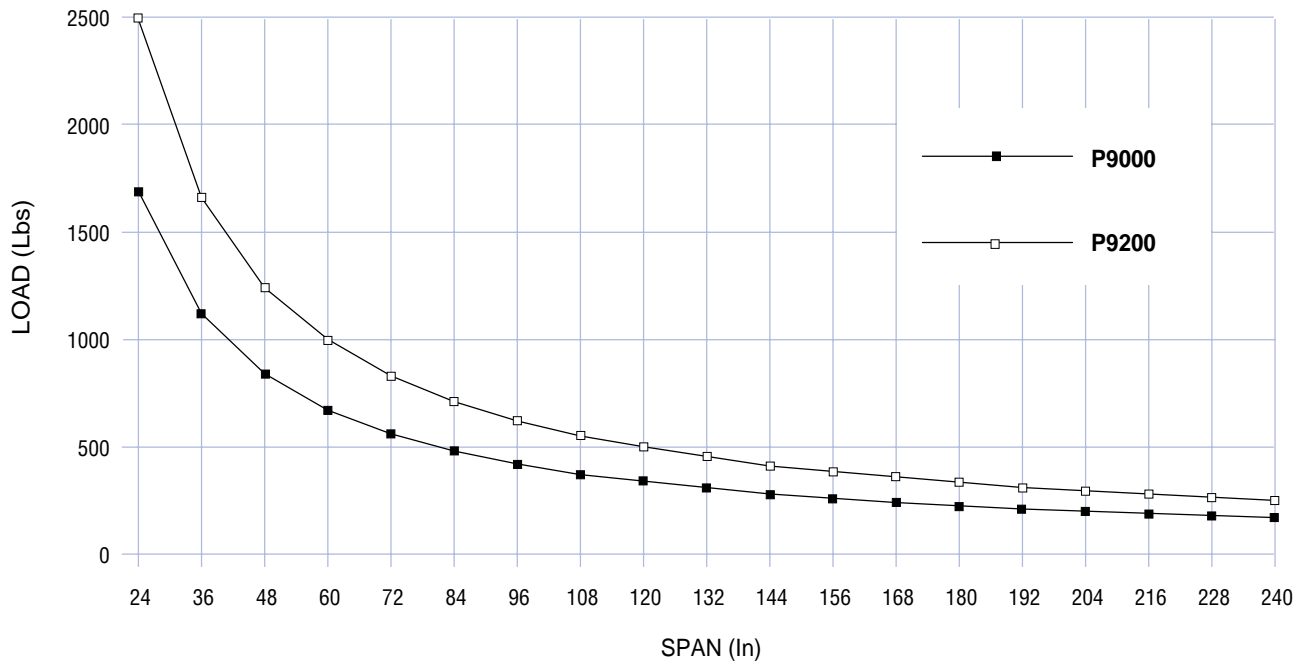

*Maximum allowable uniform load.



BEAM LOADING DATA

Span		Telestrut	Max. Allowable Uniform Load		Deflection at Uniform Load		Uniform Loading at Deflections					
							Span/180		Span/240		Span/360	
In	mm		Lbs	kN	In	mm	Lbs	kN	Lbs	kN	Lbs	kN
24	610	P9000	1690	7.5	0.06	2	1690	7.5	1690	7.5	1690	7.5
		P9200	2490	11.1	0.05	1	2490	11.1	2490	11.1	2490	11.1
36	914	P9000	1120	5.0	0.14	4	1120	5.0	1120	5.0	800	3.6
		P9200	1660	7.4	0.12	3	1660	7.4	1660	7.4	1350	6.0
48	1219	P9000	840	3.7	0.25	6	840	3.7	670	3.0	450	2.0
		P9200	1240	5.5	0.22	6	1240	5.5	1140	5.1	760	3.4
60	1524	P9000	670	3.0	0.39	10	570	2.5	430	1.9	290	1.3
		P9200	1000	4.4	0.34	9	970	4.3	730	3.2	490	2.2
72	1829	P9000	560	2.5	0.56	14	400	1.8	300	1.3	200	0.9
		P9200	830	3.7	0.49	12	670	3.0	510	2.3	340	1.5
84	2134	P9000	480	2.1	0.77	19	290	1.3	220	1.0	150	0.7
		P9200	710	3.2	0.67	17	500	2.2	370	1.6	250	1.1
96	2438	P9000	420	1.9	1.00	25	220	1.0	170	0.8	110	0.5
		P9200	620	2.8	0.87	22	380	1.7	280	1.2	190	0.8
108	2743	P9000	370	1.6	1.25	32	180	0.8	130	0.6	90	0.4
		P9200	550	2.4	1.10	28	300	1.3	220	1.0	150	0.7
120	3048	P9000	340	1.5	1.58	40	140	0.6	110	0.5	70	0.3
		P9200	500	2.2	1.37	35	240	1.1	180	0.8	120	0.5
144	3658	P9000	280	1.2	2.25	57	100	0.4	70	0.3	50	0.2
		P9200	410	1.8	1.94	49	170	0.8	130	0.6	80	0.4
168	4267	P9000	240	1.1	3.06	78	70	0.3	50	0.2	40	0.2
		P9200	360	1.6	2.7	69	120	0.5	90	0.4	60	0.3
192	4877	P9000	210	0.9	4.00	102	60	0.3	40	0.2	NR	NR
		P9200	310	1.4	3.48	88	90	0.4	70	0.3	50	0.2
216	5486	P9000	190	0.8	5.15	131	NR	NR	NR	NR	NR	NR
		P9200	280	1.2	4.48	114	70	0.3	60	0.3	40	0.2
240	6096	P9000	170	0.8	6.32	161	NR	NR	NR	NR	NR	NR
		P9200	250	1.1	5.49	139	60	0.3	50	0.2	30	0.1

NR = Not Recommended

Notes:

1. Above loads include the weight of the member. This weight must be deducted to arrive at the net allowable load the beam will support.
2. Long span beams should be supported in such a manner as to prevent rotation and twist.
3. Allowable uniformly distributed loads are listed for various simple spans, that is, a beam on two supports. If load is concentrated at the center of the span, multiply load from the table by 0.5 and corresponding deflection by 0.8.



COLUMN LOADING DATA

Unbraced Height		Telestrut	Max. Design Load Applied at Col. Face		Maximum Column Load Applied at C.G.							
					K = .65		K = .80		K = 1.0		K = 1.2	
In	mm		Lbs	kN	Lbs	kN	Lbs	kN	Lbs	kN	Lbs	kN
24	610	P9000	3420	15.2	8230	36.6	8140	36.2	7990	35.5	7810	34.7
		P9200	4420	19.7	10530	46.8	10450	46.5	10310	45.9	10130	45.1
36	914	P9000	3240	14.4	8010	35.6	7810	34.7	7480	33.3	7070	31.4
		P9200	4240	18.9	10330	46.0	10130	45.1	9820	43.7	9430	41.9
48	1219	P9000	3010	13.4	7710	34.3	7350	32.7	6760	30.1	6040	26.9
		P9200	4010	17.8	10040	44.7	9700	43.1	9130	40.6	8450	37.6
60	1524	P9000	2750	12.2	7320	32.6	6760	30.1	5840	26.0	4720	21.0
		P9200	3740	16.6	9660	43.0	9130	40.6	8250	36.7	7180	31.9
72	1829	P9000	2470	11.0	6840	30.4	6040	26.9	4720	21.0	3330	14.8
		P9200	3440	15.3	9210	41.0	8450	37.6	7180	31.9	5630	25.0
84	2134	P9000	2180	9.7	6280	27.9	5190	23.1	3520	15.7	2440	10.9
		P9200	3130	13.9	8670	38.6	7630	33.9	5910	26.3	4150	18.5
96	2438	P9000	1890	8.4	5630	25.0	4210	18.7	2690	12.0	1870	8.3
		P9200	2810	12.5	8050	35.8	6690	29.8	4570	20.3	3180	14.1
108	2743	P9000	1630	7.3	4900	21.8	3330	14.8	2130	9.5	1480	6.6
		P9200	2490	11.1	7350	32.7	5630	25.0	3610	16.1	2510	11.2
120	3048	P9000	1410	6.3	4080	18.1	2690	12.0	1720	7.7	**	**
		P9200	2180	9.7	6570	29.2	4570	20.3	2930	13.0	2030	9.0

**KL > 200
r

ELEMENTS OF SECTION

Telestrut	Areas of Section		Axis 1 - 1						Axis 2 - 2					
			I		S		r		I		S		r	
	In ²	cm ²	In ⁴	cm ⁴	In ³	cm ³	In	cm	In ⁴	cm ⁴	In ³	cm ³	In	cm
P9000	.384	2.5	.164	6.8	.203	3.3	.653	1.7	.164	6.8	.203	3.3	.653	1.7
P9200	.489	3.2	.278	11.6	.297	4.9	.754	1.9	.278	11.6	.297	4.9	.754	1.9

I - Moment of Inertia

S - Section Modulus

r - Radius of Gyration



LATERAL BRACING LOAD REDUCTION CHARTS

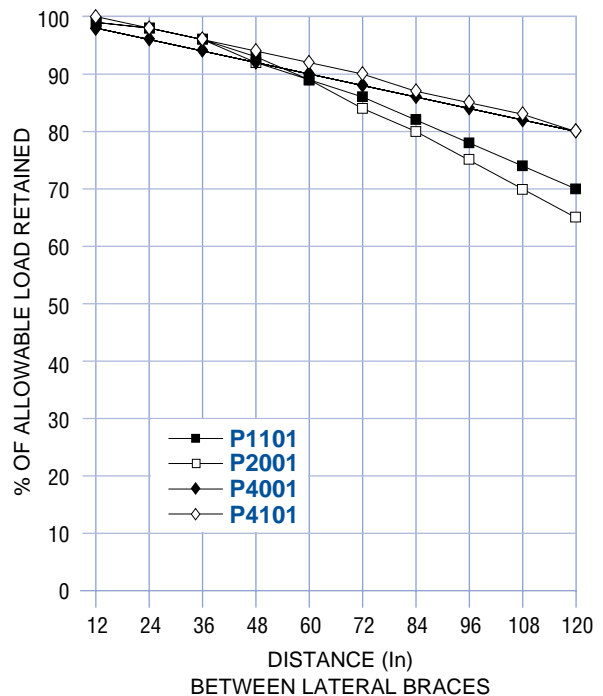
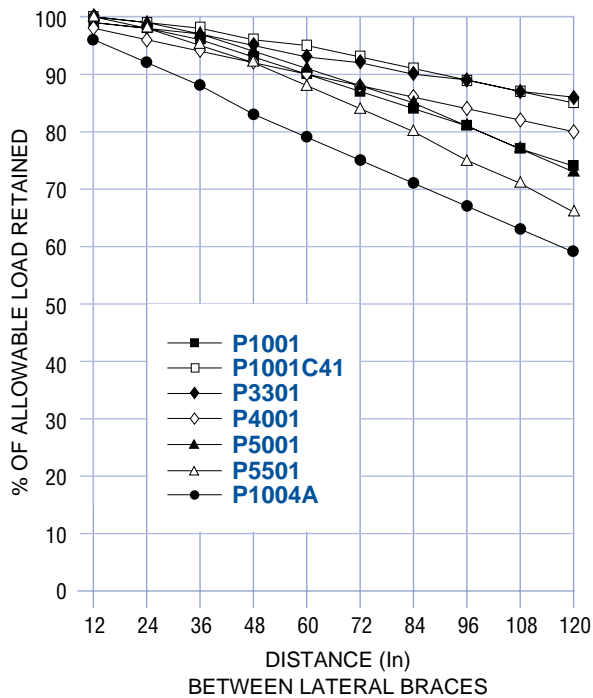
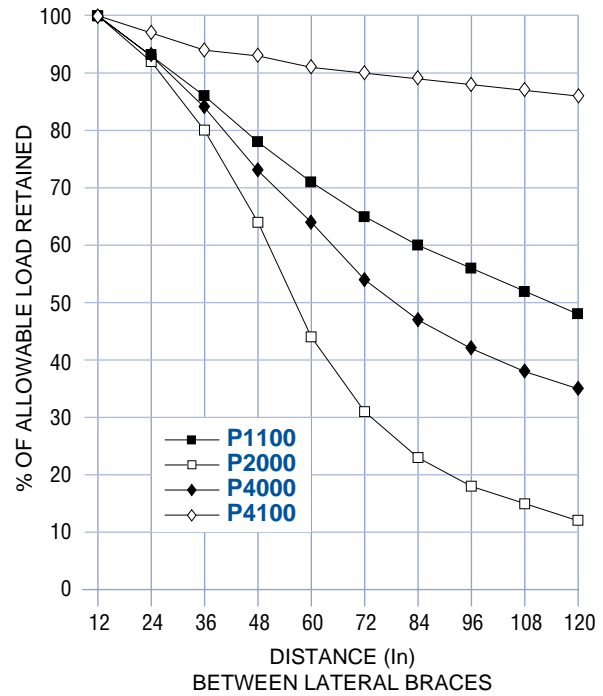
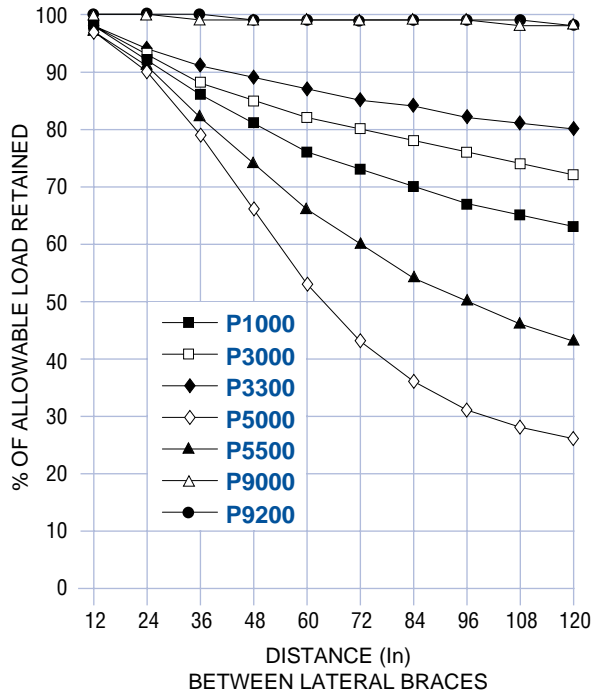

BEARING LOADS ON UNISTRUT CHANNELS

Channel	Bearing Length 1½" (41 mm)		Bearing Length 1½" (41 mm)		Bearing Length ¾"(92 mm)	
	Maximum Allowable Loads		Maximum Allowable Loads		Maximum Allowable Loads	
	Lbs	kN	Lbs	kN	Lbs	kN
P1000	5000	22.2	3500	15.6	8000	35.6
P1100	3500	15.6	2500	11.1	5500	24.5
P2000	2000	8.9	1500	6.7	3000	13.3
P3000	5000	22.2	3500	15.6	8000	35.6
P3300	6000	26.7	4000	17.8	9000	40.0
P4000	2200	9.8	1700	7.6	3500	15.6
P4100	3400	15.1	2600	11.6	4800	21.4
P5000	4000	17.8	2000	8.9	5500	24.5
P5500	5000	22.2	3500	15.6	8000	35.6
P9000	5000	22.2	3500	15.6	8000	35.6
P9200	5000	22.2	3500	15.6	8000	35.6

Nuts, Washers, Screws and Bolts

Materials

Unistrut nuts, with the exception of P1012/M16, are made from SAE 1010 cold heading quality steel bar with unique designed teeth to ensure a positive biting action into the intruded edge of the Unistrut channel.

Threads

All nuts and screws have metric coarse screw threads.

Finishes

The standard finish to all nuts and screws is a zinc electroplated coating Fe/Zn 5c 1A BS 1706:1990 or BS 3382:Part 2: 1961. Clear Passivated.

Unistrut nuts, screws washers, hex nuts etc are also available in stainless steel and HG.

N.B. Figures in brackets denote weight kg/100.

<i>M6</i>	<i>M8</i>	<i>M10</i>	<i>M12</i>	<i>M16</i>
P1006M6 (3.26)				
	P1007M8(3.53)			
		P1008M10(3..95)		
			P1010M12(4.78)	
			P1013M12(3.43)	

<i>M6</i>	<i>M8</i>	<i>M10</i>	<i>M12</i>	<i>M16</i>
P4006M6 (3.10)				
	P4007M8(3.53)			
		P4008M10(3..90)		
			P4010M12(3.63)	

<i>M6</i>	<i>M8</i>	<i>M10</i>	<i>M12</i>	<i>M16</i>
P3006M6 (3.10)				
	P3007M8(3.53)			
		P3008M10(3..80)		
			P3010M12*(4.63)	
			P3013M12(3.63)	
				P1012M16*(8.00)

* Not suitable for P3300 & P4000 Channels.

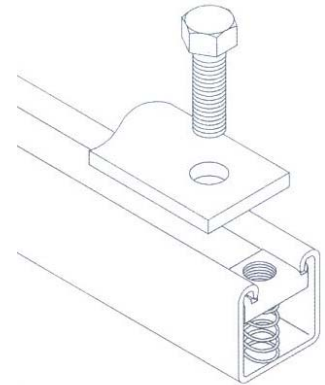

Channel Sprung Nut

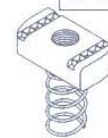

Finishes: ZP, HG & SS

Suitable for P1000, P2000 & P3270

Channel Sprung Nut



Finishes: ZP, HG & SS

Suitable for P3300, P4000, P3370 & P4270

Channel Nut

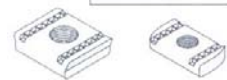

Finishes: ZP, HG & SS

Suitable for P1000, P2000, P3300, P4000, P5000, P5500 & P3270

M5 & M6 Channel Nut

<i>M6</i>
M6006M6 (0.62)



Finishes: ZP, HG & SS

Suitable for M5 & M6 Channels

M6	M8	M10	M12	M16
M6 x 30SN(4.00)	M8 x 30SN(5.20)	M10 x 30SN (6.40)	M12 x 30SN (7.30)	M16 x 63SN * (12.89)
	M8 x 50SN (6.00)	M10 x 50SN (7.60)	M12 x 50SN (9.10)	M16 x 102SN * (27.20)
		M10 x 75SN (9.20)	M12 x 75SN (11.40)	
			M12 x 100SN (21.11)	

* M16 forged stud nut.

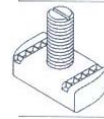
Stud Nut

Finishes: ZP

Fits all Channel Sizes

M6
M6 x 22SN(0.87)
M6 x 40SN(0.93)

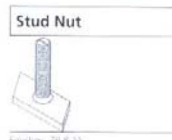

Suitable for M5 & M6 Channels

M6	M8	M10	M12	M16
M6 x 13HS(0.45)*	M8 x 25HS(1.10)	M10 x 20HS (2.22)	M12 x 22HS (3.53)	M16 x 50HS (10.30)
M6 x 20HS(0.54)*	M8 x 35HS (1.40)	M10 x 25HS (2.57)	M12 x 25HS (3.76)	M16 x 70HS (13.90)
M6 x 25HS(0.66)*	M8 x 40HS (1.60)	M10 x 30HS (2.82)	M12 x 30HS (4.15)	
M6 x 30HS(0.86)*		M10 x 40HS (3.07)	M12 x 40HS (4.93)	
M6 x 50HS(1.11)*		M10 x 45HS (3.50)	M12 x 45HS (5.00)	
		M10 x 50HS (3.75)	M12 x 50HS (5.50)	
		M10 x 55HS (4.00)		
		M10 x 60HS (4.20)		
		M10 x 65HS (4.40)		

- No available in HG

Hex. Head 8.8 Set Screw

Finishes: ZP, HG & SS

M6	M8	M10	M12	M16
M6 HN(0.15)*				
	M8 HN (0.40)			
		M10 HN (0.74)		
			M12 HN (1.77)	
				M16 HN (3.29)

* Finishes ZN10

Hex. Nut Grade 8.8

Finishes: ZP, HG & SS

M6	M8	M10	M12	M16
M6 FW (0.06)*				
	M8 FW (0.17)			
		M10 FW (0.28)		
			M12 FW (0.42)	
				M16 FW (0.73)

* Finishes ZN10

Flat Washer

Finishes: ZP, HG & SS

M6	M8	M10	M12	M16
M6 LW (0.05)*				
	M8 LW (0.06)			
		M10 LW (0.07)		
			M12 LW (0.09)	
				M16 LW (0.13)

* Finishes ZN10

Lock Washer

Finishes: ZP, HG & SS

Screws, Threaded Rod and Sockets

<i>M6</i>	<i>M10</i>
M6 X 16CS (3.85)	M10 X 20CS (1.25)

Counter Sunk Screw



Finishes: ZP & SS

<i>M6</i>
M6 X 16PH (0.44)
M6 X 20PH (0.53)
M6 X 25PH (0.64)

Pan Head Screw



Finishes: ZP & SS

<i>M6</i>
M6 X 12RB (0.43)
M6 X 16RB (0.54)
M6 X 20RB (0.63)
M6 X 25RB (0.77)

Roofing Nut & Bolt

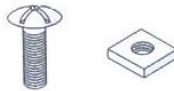

Finishes: ZP

<i>M6</i>	<i>M8</i>	<i>M10</i>	<i>M12</i>
M6 x 1m Grade 8.8 (17.50)			
	M8 x 1m Grade 4.6 (30.54)		
		M10 x 1m Grade 4.6 (48.76)	
			M12 x 1m Grade 4.6 (70.63)

N.B. Other lengths available on request.

Threaded Rod/Studding



Finishes: ZP & SS

<i>M10</i>	<i>M12</i>
M10 x 40CP (2.50)	
	M12 x 40CP (3.90)

Cone-Pointed Screw



Finishes: ZP & SS

<i>M10</i>	<i>M12</i>
12 AF	
	19AF

NEW

Channel Socket

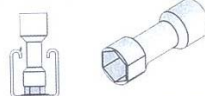

Finishes: Chrome Vanadium

Suitable for use with torque wrench to achieve recommended torques inside standard channels.

Channel Nut Performance in All Channel

Pre Galvanized & Hot Dip Galvanized Channel

Recommended safe working loads for Zinc-plated nuts, stud nuts and zinc-plated grade 8.8screws in pre-galvanized or hot-dip galvanized mild steel channel. Tested in accordance with BS 6946:1988.

Slip performance in serrated channel is identical to plain channel.

To simplify the table, channel nuts only are shown. Unistrut nuts with springs will have identical performance.

Channel Type	Nut Type	Torque Nm	Pull—Out Kg	Slip Kg
P1000, P5000 & P5500	P3006M6	12	500	100
	P3007M8	28	600	240
	P3008M10	55	700	350
	P3010M12	95	900	680
	P3012M16	125	1200	750
	M16 Forged Stud Nut	95	900	-

Channel Type	Nut Type	Torque Nm	Pull—Out Kg	Slip Kg
P3300	P3006M6	12	500	100
	P3007M8	28	600	240
	P3008M10	55	700	350
	P3013M12	60	700	400
	M16 Forged Stud Nut	95	900	-

Channel Type	Nut Type	Torque Nm	Pull—Out Kg	Slip Kg
P2000	P3006M6	12	350	100
	P3007M8	28	375	240
	P3008M10	55	425	350
	P3010M12	55	450	360
	P3012M16	95	500	450
	M16 Forged Stud Nut	70	450	-

Channel Type	Nut Type	Torque Nm	Pull—Out Kg	Slip Kg
PP4000	P3006M6	12	350	100
	P3007M8	28	375	240
	P3008M10	55	425	350
	P3013M12	55	450	360
	P3012M16	70	450	-

Stainless Steel Channel

Recommended safe working loads for stainless steel nuts, stud nuts and screws in stainless steel channels grade 316:S31. Tested in accordance with BS6946:1988.

Improved slop loadings are achieved using serrated channels.

To simplify the table, channel nuts only are shown. Unistrut nuts with springs will have identical performance.

Channel Type	Nut Type	Torque Nm	Pull—Out Kg	Plain Channel Slip Kg	Serrated Channel Slip Kg
P1000	P3006M6	6.5	250	30	100
	P3007M8	16	450	60	240
	P3008M10	31.5	700	120	350
	P3013M12	55	700	170	400
	P3012M16	125	1200	400	750

Channel Type	Nut Type	Torque Nm	Pull—Out Kg	Plain Channel Slip Kg	Serrated Channel Slip Kg
P3300	P3006M6	6.5	250	30	100
	P3007M8	16	450	60	240
	P3008M10	31.5	700	120	350
	P3013M12	55	700	170	400

Flat Plate Fittings

P1062 to P1064

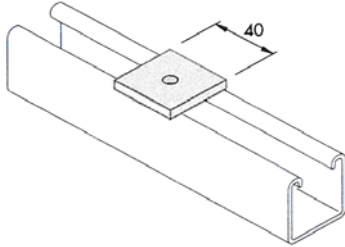

Finishes : HG & SS

	Hole Size mm	Thread Size mm	Weight each gms
P1062	8	6	72
P1062/A	10	8	71
P1063	12	10	70
P1064	14	12	68

P1067

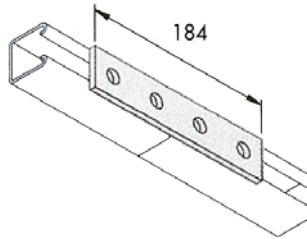

Finishes : HG & SS, Weight 311g

P1941

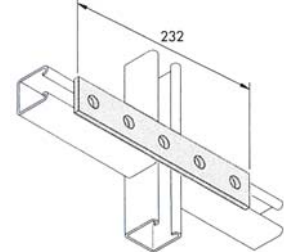

Finishes : HG & SS, Weight 400g

P1063-S1

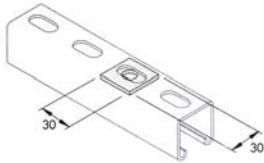

For internal Applications.
P1063-S1 use inside of drilled or slotted channel as load spreading washer.

Finishes : HG & SS, 3 mm thick

	Hole Size mm	Thread Size mm	Weight each gm.
P1063-S1/06	8	6	72
P1063-S1/08	10	8	71
P1063-S1/10	12	10	70
P1063-S1/12	14	12	68

P1064-S1

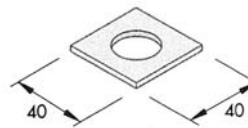

Finishes : ZP , 3 mm thick

Hole Size mm	Weight each gm
22	30

P1065

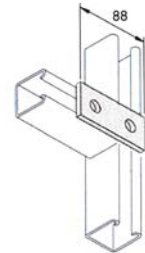

Finishes : HG & SS,
Weight 160g

P1066

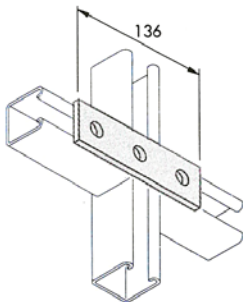

Finishes : HG & SS, Weight 240g

P2322

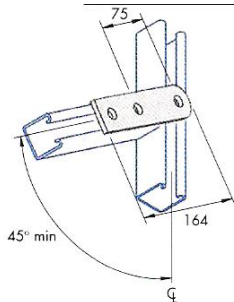

Finishes : HG & SS, Weight 305g

P1036

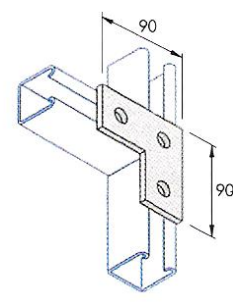

Finishes : HG & SS, Weight 250g

P1031

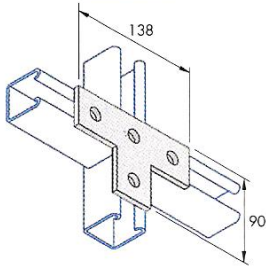

Finishes : HG & SS, Weight 340g

P1358

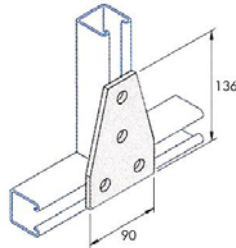

Finishes : HG & SS, Weight 450g

P1580

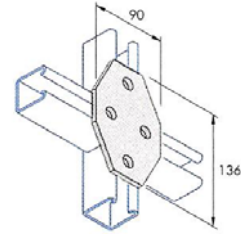

Finishes : HG & SS, Weight 470g

P1962

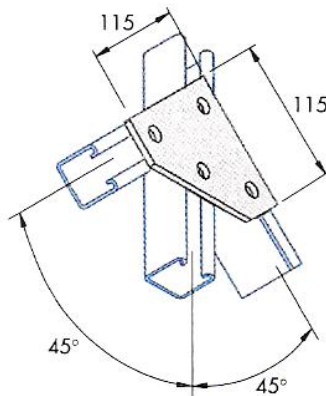

Finishes : HG & SS, Weight 448g

90° Fittings

P1026 & P1026-S1

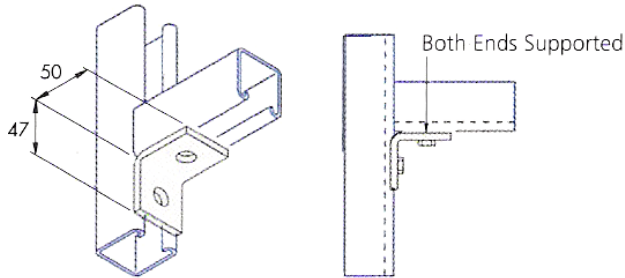

P1026 Only

Load P1000 680 Kgf

P2000 340 kgf

Finishes

P1026 – HG & SS

P1026-S1 ZP

Weight P1026 150g

P1026-S1 – 71 g, 3 mm thick

P1033

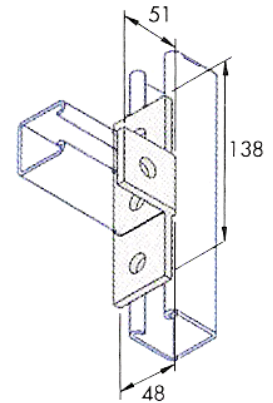

Finishes : HG & SS, Wt. 340 g

P1068

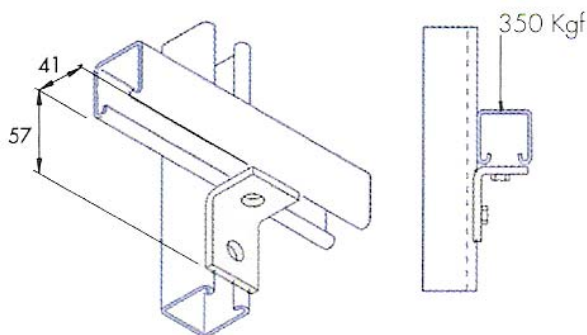

Finishes : HG & SS, Wt. 150 g

P1060-S1

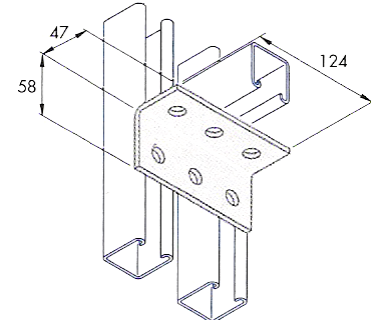

Finishes : HG & SS, Wt. 426 g, 5 mm thick

P1326

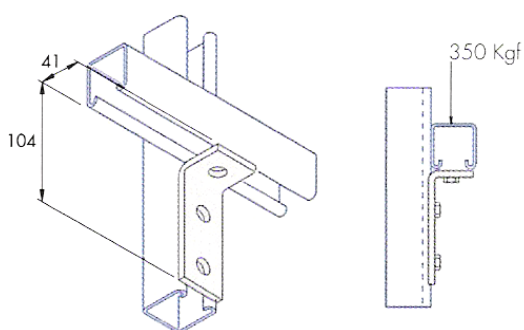

Finishes : HG & SS, Wt. 240 g

P2484

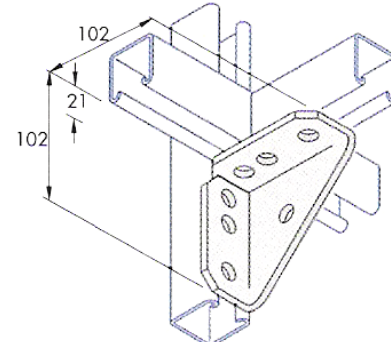

Finishes : HG & SS, Wt. 560 g

P1325

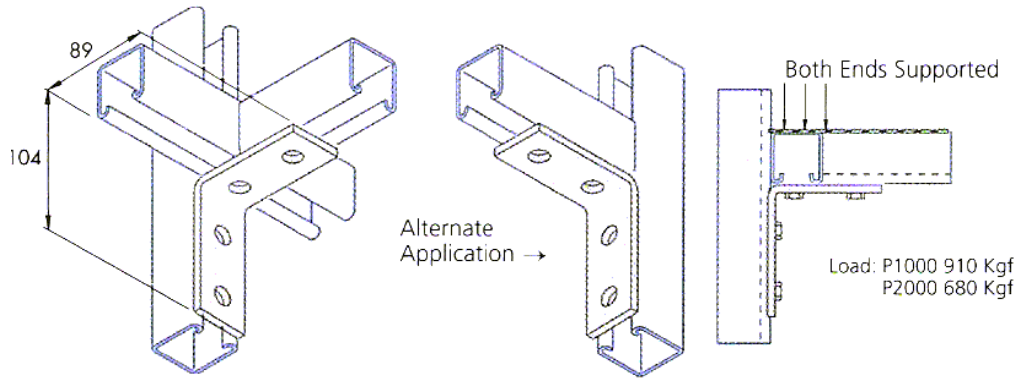

Finishes : HG & SS, Wt. 311 g

P1068

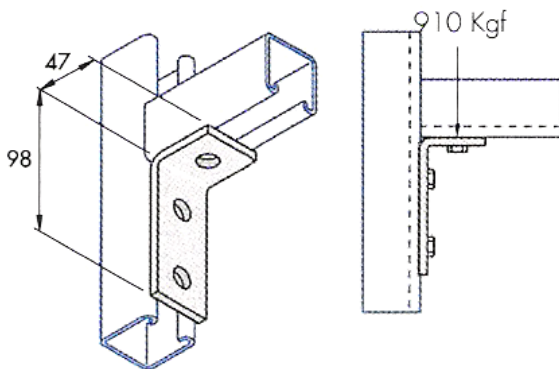

Finishes : HG & SS, Wt. 240 g

P1037

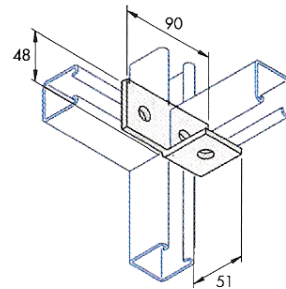

Finishes : HG & SS, Wt. 250g

P1458

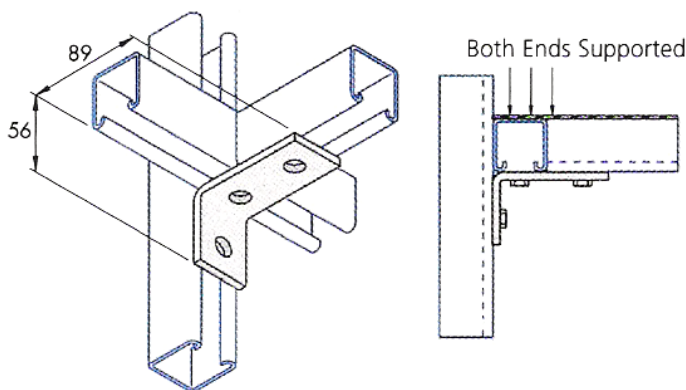

Load P 1000 680 Kgf
P 2000 450 Kgf
Finishes : HG & SS, Wt. 240 g

P1038

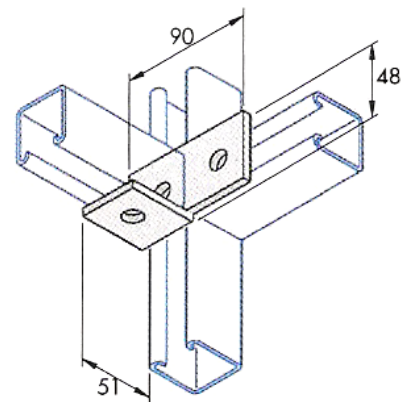

Finishes : HG & SS, Wt. 250 g

P1278

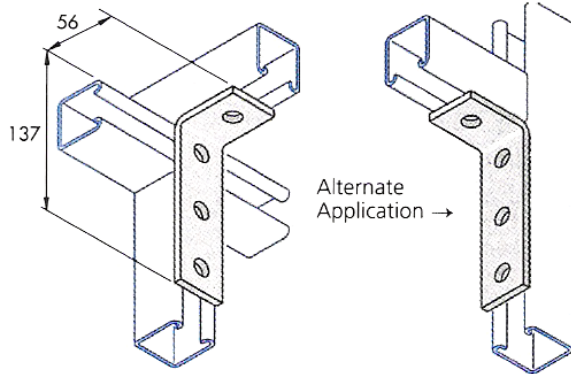

Finishes : HG & SS, Wt. 311 g

P1359

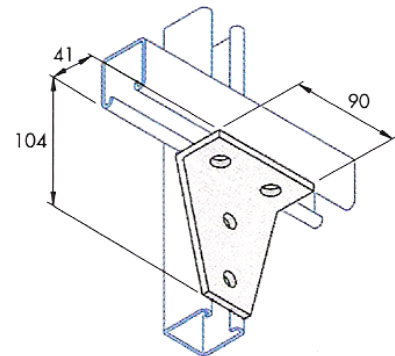

Finishes : HG & SS, Wt. 450 g

P2235

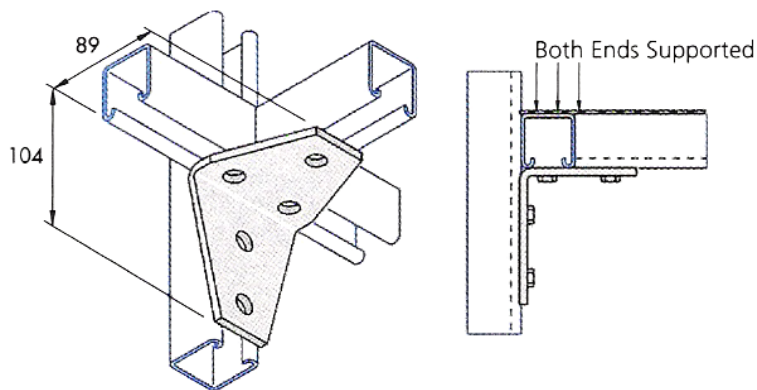

Load P 1000 910 Kgf
P 2000 680 Kgf

Finishes : HG, Wt. 560 g

P1060-S1

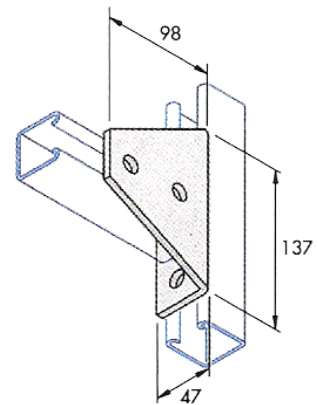

Finishes : HG & SS, Wt. 650g

Angled Fittings

P1546, P2095 & P2097

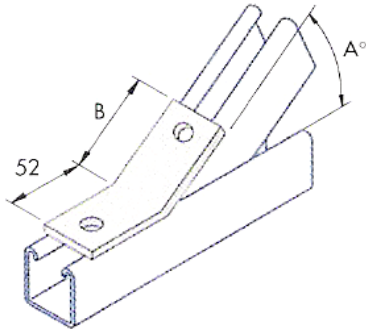

Finishes : HG & SS

	A	B mm	Weight each gms
P1546	45°	82	252
P2097	60°	81	246
P2095	75°	80	246

P1191

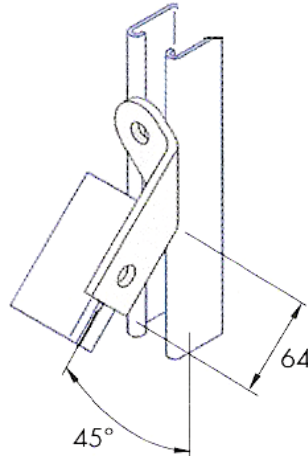

Finishes : HG , Weight 230g

P 1886, P2106 & P2108

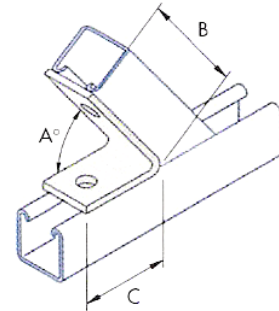

Finishes : HG & SS, Weight 246g

	A	B mm	C mm
P1186	45°	77	64
P2108	60°	79	64
P2106	75°	81	64

P2101 & P2103

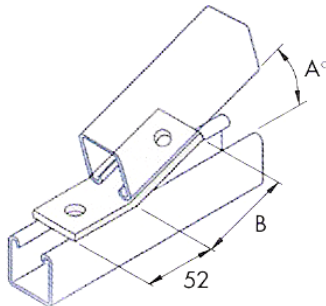

Finishes : HG & SS, 246g

	A	B mm
P2103	15°	84
P2101	30°	82.5

P1074

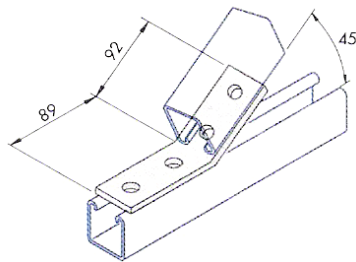

Finishes : HG & SS ,Weight 311 g

P1354

Adjustable Hinge Fitting

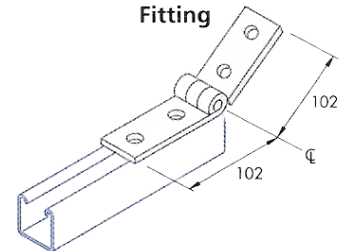

Finishes : ZP , Weight 452g

P 1192

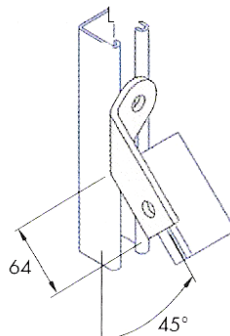

Finishes : HG, Weight 230g

U & Z Shaped Fittings

P1043

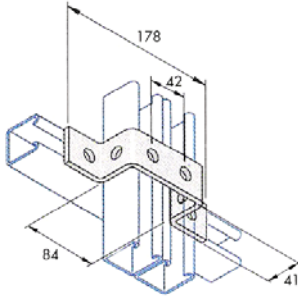

Finishes : HG & SS, Weight 430g

P1047

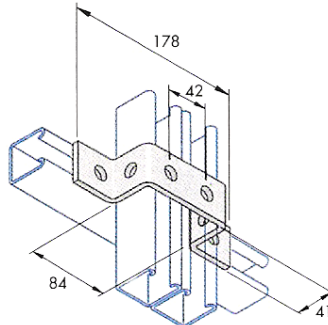

Finishes : HG & SS, Weight 340g

P4045

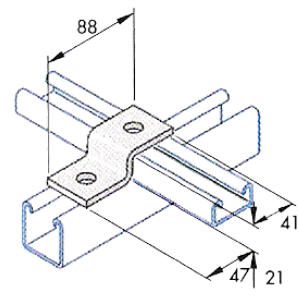

Finishes : HG & SS, Weight 186g

P1044

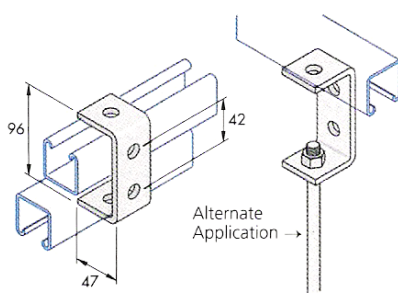

Finishes : HG & SS, Weight 320g

P1737

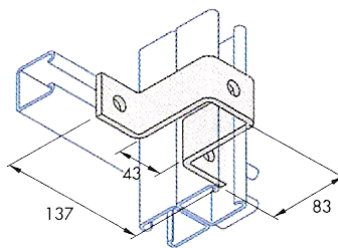

Finishes : HG & SS, Weight 547g

P1453

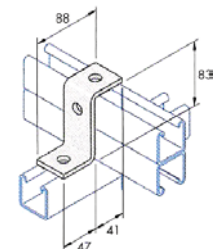

Finishes : HG & SS, Weight 312g

P1045

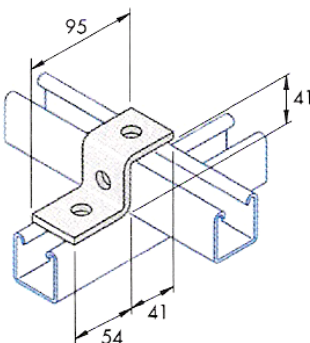

Finishes : HG & SS, Weight 216g

P4047

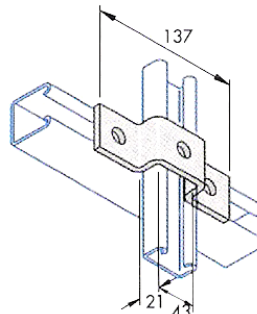

Finishes : HG & SS, Weight 292g

P1347

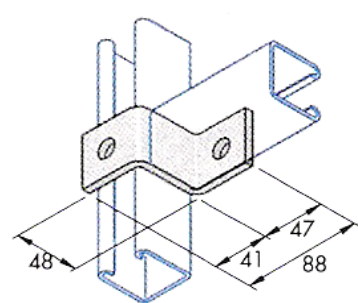

Finishes : HG & SS, Weight 235g, 48 mm offset

P1377

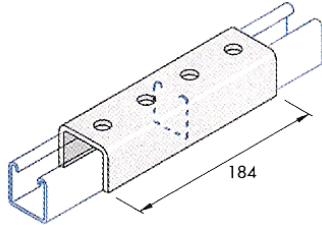

Finishes : HG & SS, Weight 939g,
5mm thick

P1218

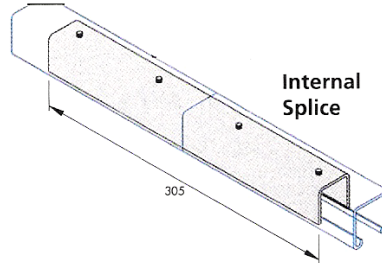

P1218 for use with P1000, p1001, P2000
and P2001 channel.

N.B. 4 No. M6 Pan head fixing screws are
included.

Finishes : ZP & SS, Weight 539g, 2.5
mm thick

P1219

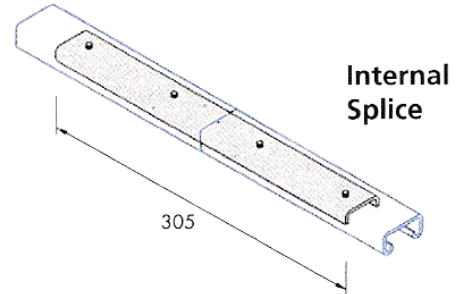

P1219 for use with P3300, P331, P4000 and
P4001 channel.

N.B. 4 No. M6 Pan head fixing screws are included.

Finishes : ZP & SS, Weight 305g, 2.5 mm
thick

Base Plates & Wing fittings

P2072-S1

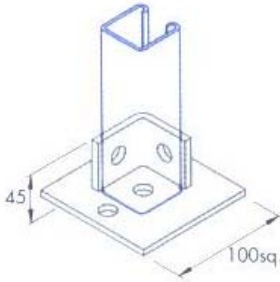

Finishes : HG & SS, Wt. 575g, base Plate
5mm thick

P2223

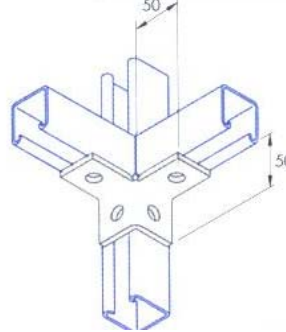

Finishes : HG & SS, Wt. 317g

P2346

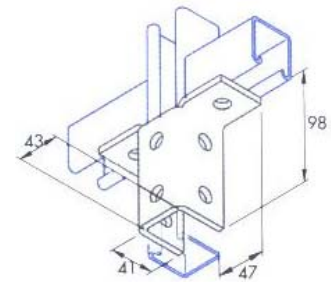

Finishes : HG & SS, Wt. 662g

P2072-S2

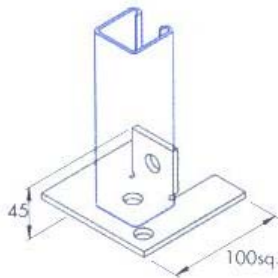

Finishes : HG & SS, Wt. 393g, Base Plate
5 mm thick

P2341 R

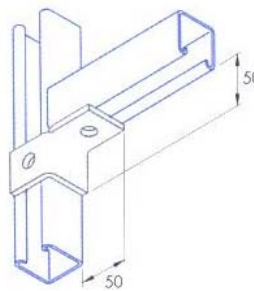

Finishes : HG & SS, Wt. 240g

P2341 L

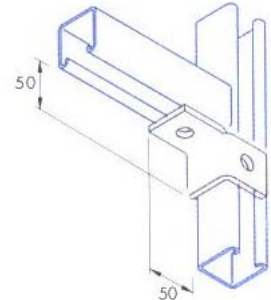

Finishes : HG & SS, Wt. 240g

P2072-S3

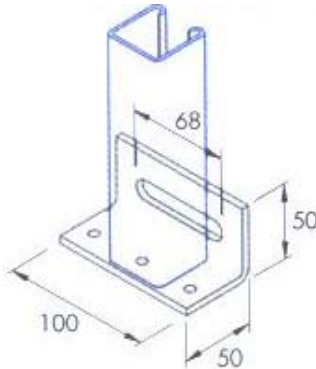

Finishes : HG, Wt. 314g, Attachment slot 14mm
wide Base plate 5mm thick Holes in base 7mm O

P 2348-S1

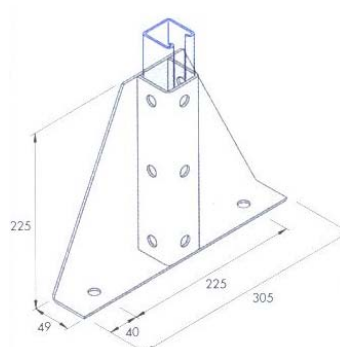

**For use with P1000 & P3301
Channel**
Finishes : HG & SS, Wt. 2209g, 3mm thick

P2348-S2

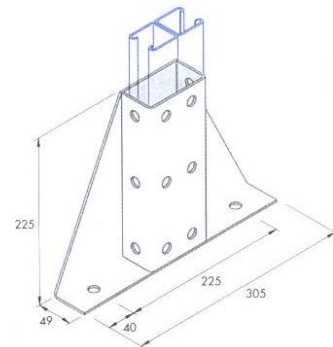

**For use with P1001 & P5000
Channel**
Finishes : HG & SS, Wt. 2438g, 3mm thick

P2073

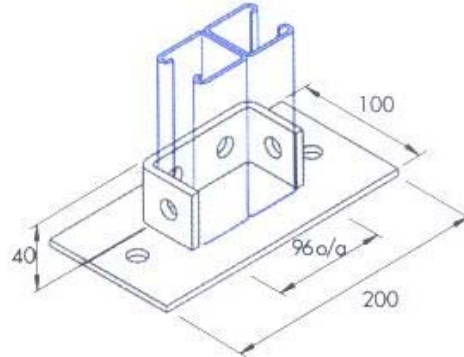

Finishes : HG & SS, Wt. 1094g, Base plate 5mm thick

M5 / M6 Fittings

N.B. General data subject to commercial tolerances. Hole size 7mm diameter. Hole spacing 12.5 mm from end, 28.5 from center. Width 25mm . Thickness 3mm unless noted otherwise.

To achieve maximum loading M6 x 13 High Tensile Unistrut machine Screws should be used, tightened to 12Nm torque.

25/1064

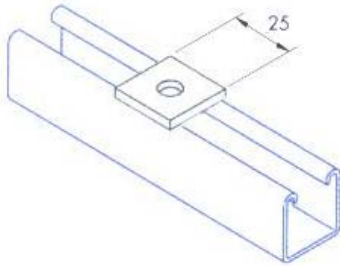

Finishes: ZP, Wt. 15g

25/1065

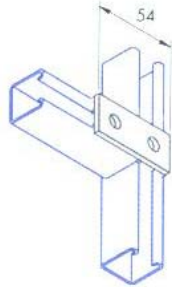

Finishes: ZP, Wt. 30g

25/1067

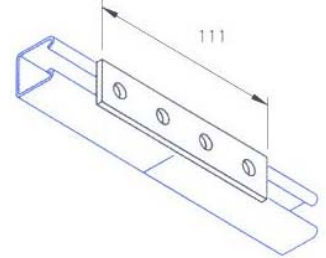

Finishes: ZP, Wt. 65g

25/1068

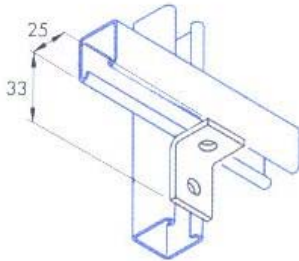

Finishes: ZP, Wt. 31g

25/1066

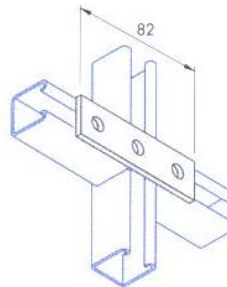

Available on Special Other

25/1278

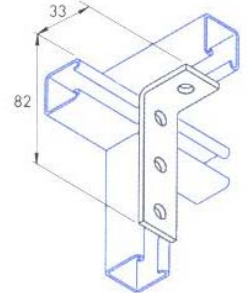

Available on Special Other

25/1047

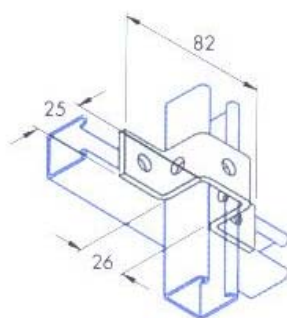

Finishes: ZP, Wt. 72g

25/1326

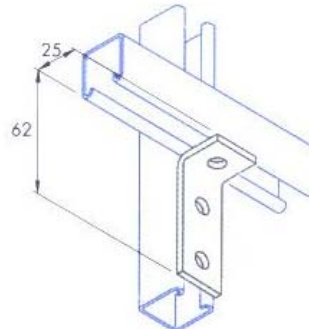

Available on Special Other

25/4007

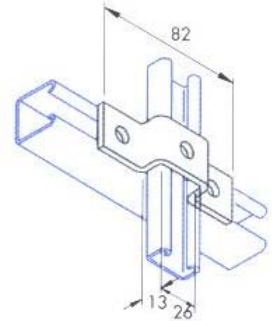

Available on Special Other

25/1184

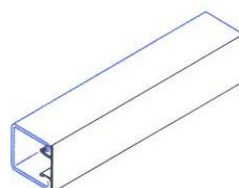

Finishes: White PVC , Standard Length 3m, Wt. 7 g/m

Special Order Fittings

P2356 & P2356-6

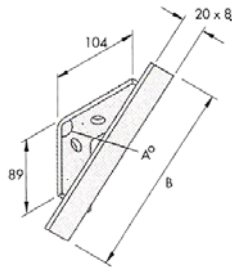

	A	B
P2356	90°	175 mm
P2356-6	97.5°	193 mm

P1356

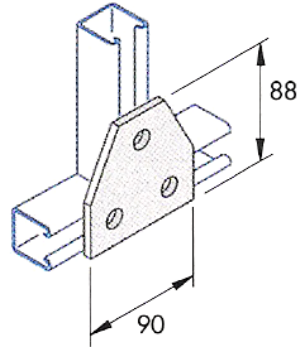

P1474

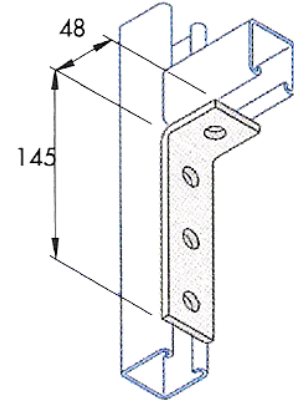

P1953

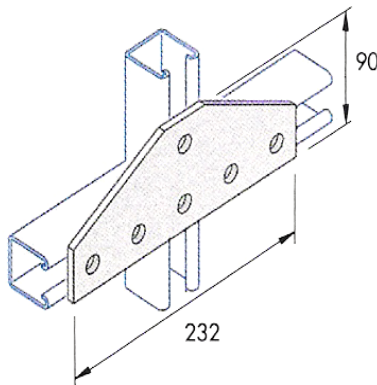

P1034

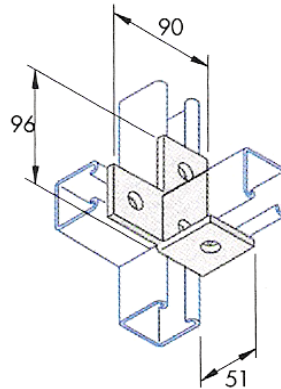

P1992

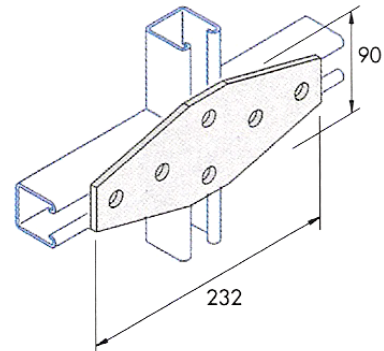

P1035

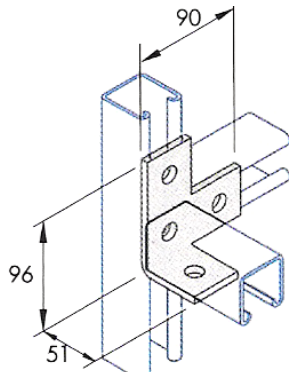

P1070

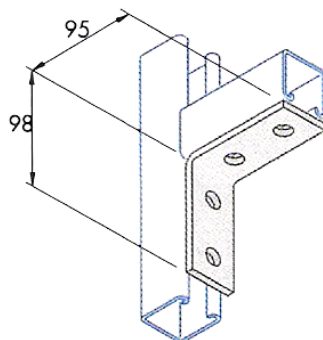

P1357

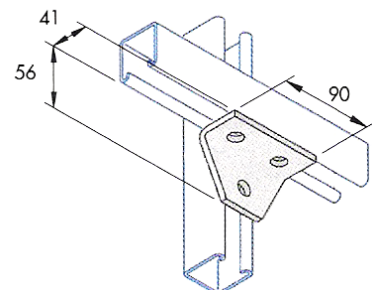

P1579

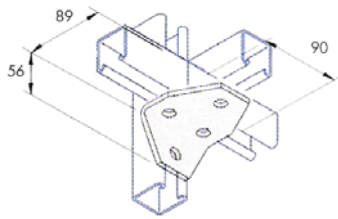

P1993

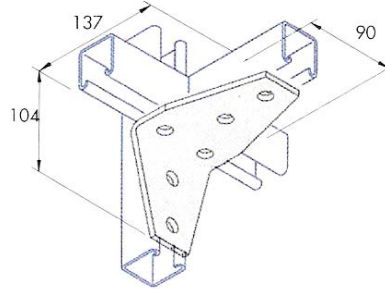

P4347

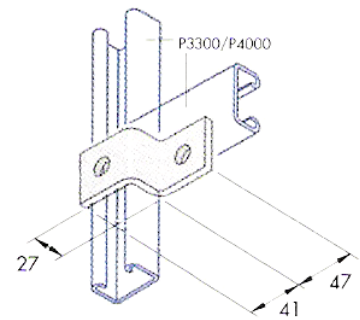

P1945

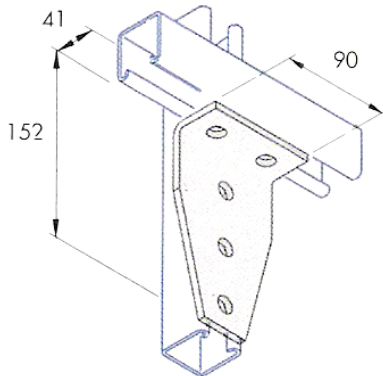

P1032

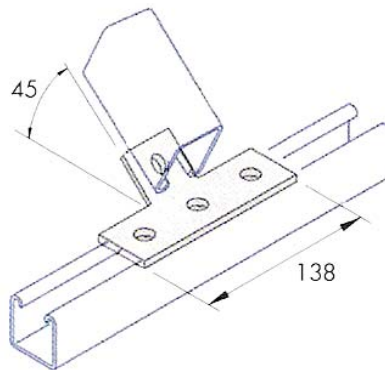

P1736

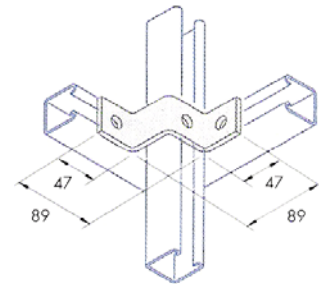

P1954

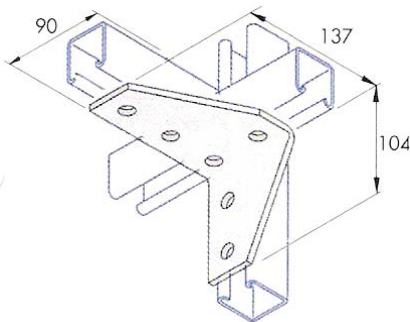

P1073

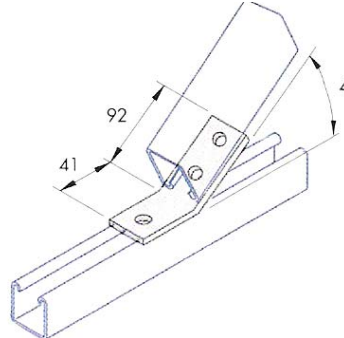

P4376-A

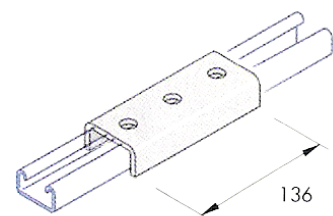

P1955

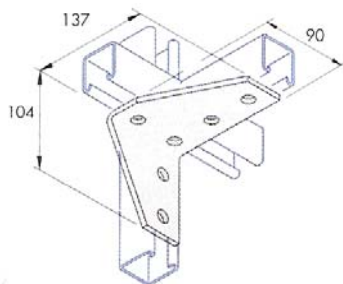

P1046-A

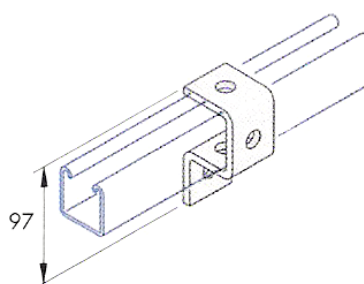

P4376

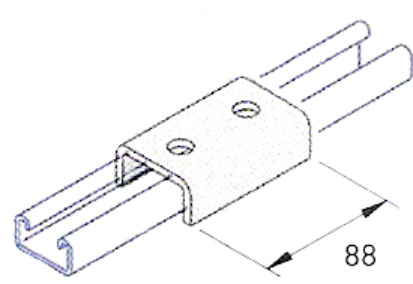

Beam Clamps

P1386

Min. of two fixings to be used.

Recommended Max. load per clamps

P1000 270 Kgf

P2000 200 Kgf

Max. flange thickness equals 13mm. Recommended torque 70Nm.

N.B. M12 x 40 bolt & channel nuts to be ordered separately.

Finishes : HG & SS, Wt. 101g each.

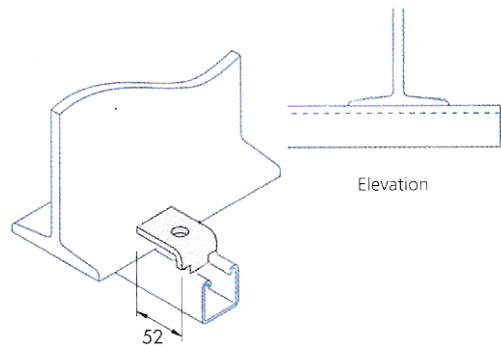

P2489

Min. of two fixings to be used.

Recommended Max. load per clamps

P1000 300 Kgf

P2000 125 Kgf

Max. flange thickness equals 22mm. Cone-pointed screw-torque 12 Nm.

N.B. Screws included in bracket.

Finishes : HG, Wt. 220g each.

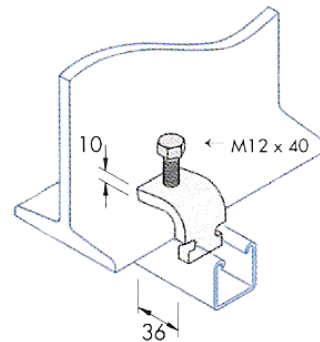

P1796

Min. of two fixings to be used.

Recommended Max. load per clamps = 220 Kgf

Max. flange thickness equals 22mm. Cone-pointed screw-torque 12 Nm.

N.B. Screws included in bracket.

Finishes : HG & SS, Wt. 430g each.

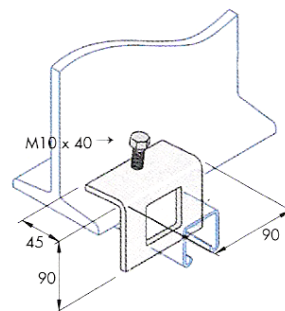

P1796-A

Min. of two fixings to be used.

Recommended Max. load per clamps = 220 Kgf

Max. flange thickness equals 22mm when used with P3300 / P4000 Channel. Cone-pointed screw – torque 15 Nm.

N.B. Screw included with bracket.

Finishes : HG & SS, Wt. 390g each.

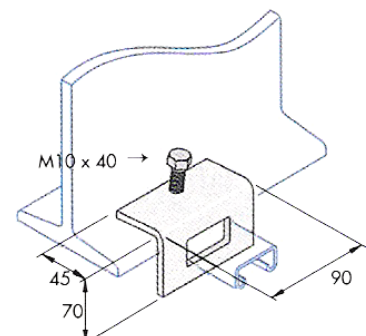

P1271

Min. of two fixings to be used.

Recommended Max. load per clamps = 230 Kgf

Max. flange thickness equals 22mm when used with P1000 channel. Cone-pointed screw – torque 20Nm.

N.B. Screw included with bracket.

Finishes : HG & SS, Wt. 477g each.

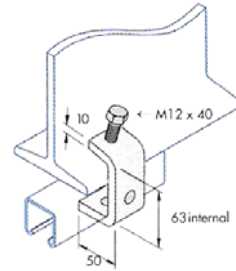

P1272

Min. of two fixings to be used.

Recommended Max. load per clamps = 200 Kgf

Max. flange thickness equals 22mm when used with P1000 Channel. Cone-pointed screw - torque 10 Nm.

N.B. Screw included with bracket.

Finishes : HG & SS, Wt. 137g each.

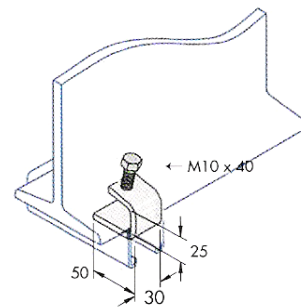

P1983

Min. of two fixings to be used.

Recommended Max. load per clamps = 270 Kgf

Max. flange thickness equals 46mm when used with P1000 Channel. Cone-pointed screw - torque 20 Nm.

N.B. M12 Screw & Channel nut to be ordered separately.

Finishes : HG & SS, Wt. 508g each.

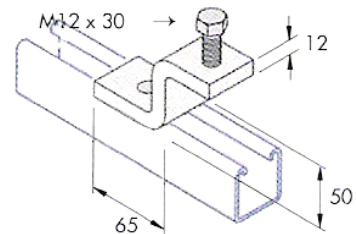

P1386-S1

Fixing Clamp

3Mm thick fixing clamp for fixing cable ladder to Unistrut Channel. M10 screw & Channel nut to be ordered separately.

Finishes : ZP, Wt. 42g each.

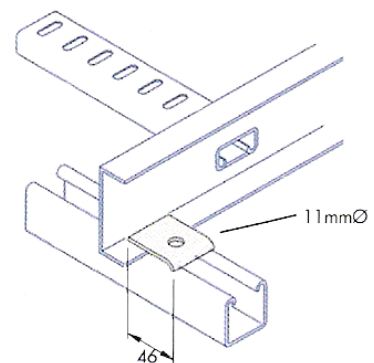

P2785

Min. of two fixings to be used.

Recommended Max. load per clamps (P1000, P2000, P3300, P3301, P4000, P4001) = 455 Kgf

Max. clamping height 22mm Hex nuts – torque 22Nm
 Finishes : Zp & SS, Wt. 360g each.

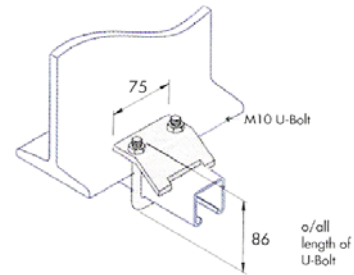

P2786

Min. of two fixings to be used.

Recommended Max. load per clamps (P1001, P2001, P5000, P5500) = 455 Kgf

Max. clamping height 22mm. Hex nuts – torque 22Nm.

Finishes : ZP & SS, Wt. 400g each.

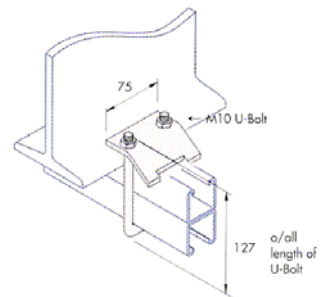

P3087

Use in pairs

Part No. P3087 consists of a) P3087 A * , b) P3087 B

	Pull Out Kgf	Slip Kgf
P1000	400	360
P2000	225	135

If the load does not act centrally within dim A then the above load should be halved.

Loads quoted apply to both ho-dip galvanized and stainless steel materials.

Con-pointed screws – torque 22Nm.

* inc. two screw.

Finishes : HG & SS, Wt. 670g each.

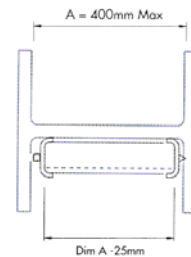
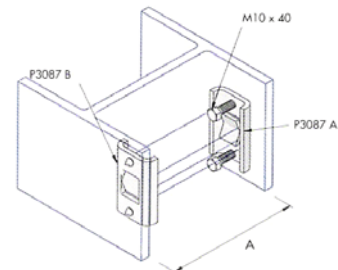

Cantilever Arms

P 2663

Recommended UDL Kgf for Vertical Channel

	<i>A mm</i>	<i>P1000</i>	<i>P2000</i>	<i>Wt. Each Kg.</i>
P2663 / 150	160	680	450	0.80
P2663 / 300	310	356	304	1.17
P2663 / 450	460	240	205	1.59
P2663 / 600	610	181	154	2.03
P2663 / 750	760	143	124	2.53

Finishes : HG, SS

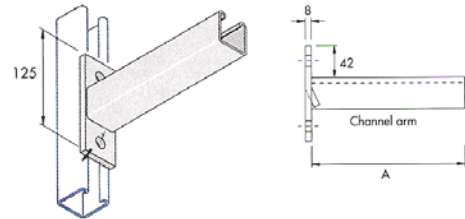

Two bolts fixing can be used in the inverted position.

P2663T

Recommended UDL Kgf for Vertical Channel

	<i>A mm</i>	<i>P1000</i>	<i>P2000</i>	<i>Wt. Each Kg.</i>
P2663T / 150	175	639	450	0.82
P2663T / 300	325	330	304	1.24
P2663T / 450	475	222	205	1.65
P2663T / 600	625	167	154	2.06
P2663 / 750	775	134	124	2.47

Finishes : HG

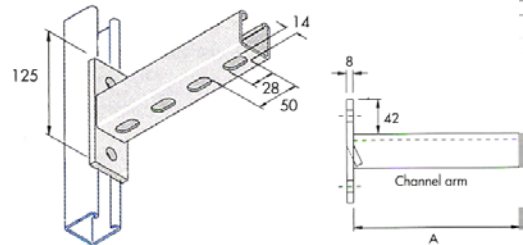

Two bolts fixing can be used in the inverted position.

P2668

Recommended UDL Kgf for Vertical Channel

	<i>A mm</i>	<i>P1000</i>	<i>P2000</i>	<i>Wt. Each Kg.</i>
P2668 / 150	160	680	450	0.80
P2668 / 300	310	356	304	1.17
P2668 / 450	460	240	205	1.59
P2668 / 600	610	181	154	2.03
P2668 / 750	760	143	124	2.53

Finishes : HG, SS

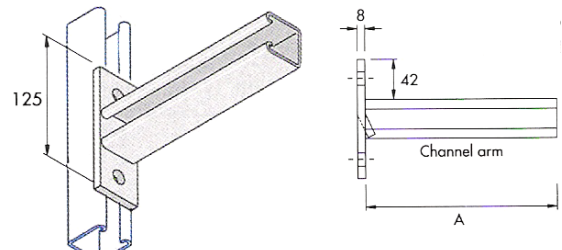

Two bolts fixing can be used in the inverted position.

P2664

Recommended UDL Kgf for Vertical Channel

	<i>A mm</i>	<i>P1000</i>	<i>P2000</i>	<i>Wt. Each Kg.</i>
P2664 / 150	150	680	450	0.91
P2664 / 300	300	475	280	1.40
P2664 / 450	450	300	180	1.69
P2664 / 600	600	225	140	2.23
P2664 / 750	750	180	118	2.58

Finishes : HG, SS – UK patent No. 2031751

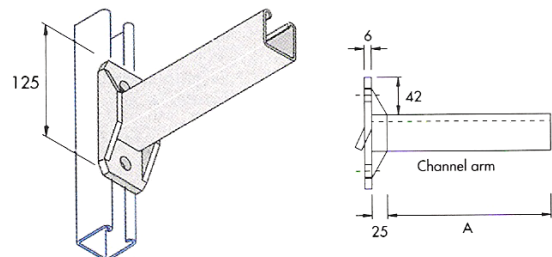

Single bolt fixing (top hole only required).
Can be used in inverted position to that illustration.

P2665

Recommended UDL Kgf for Vertical Channel

	<i>A mm</i>	<i>P1000</i>	<i>P2000</i>	<i>Wt. Each Kg.</i>
P2665 / 300	310	609	304	2.13
P2665 / 450	460	410	205	3.01
P2665 / 600	610	309	154	3.72
P2665 / 750	760	248	124	4.66

Finishes : HG, SS

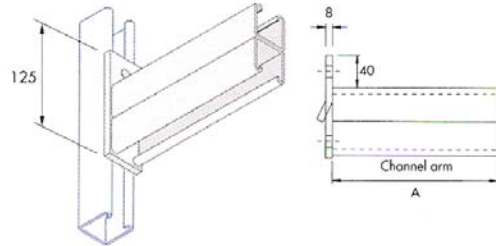

Single bolt fixing (top hole only required)

P2667

Recommended UDL Kgf for Vertical Channel

	<i>A mm</i>	<i>P1000</i>	<i>P2000</i>	<i>Wt. Each Kg.</i>
P2667 / 300	310	356	304	2.20
P2667 / 450	460	240	205	2.60
P2667 / 600	610	181	154	2.99

N. B. Other lengths available to order.

Finishes : HG

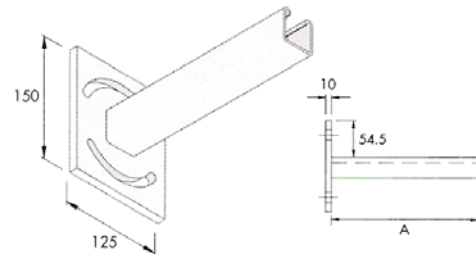

Two bolts fixing can be used in the inverted position.

P2666

Recommended UDL Kgf for Vertical Channel

	<i>A mm</i>	<i>B mm</i>	<i>P1000</i>	<i>P2000</i>	<i>Wt. Each Kg.</i>
P2666 / 750	760	270	460	230	4.63
P2666 / 900	910	330	460	230	4.78
P2666 / 1050	1060	380	460	230	5.67

Finishes : HG, SS

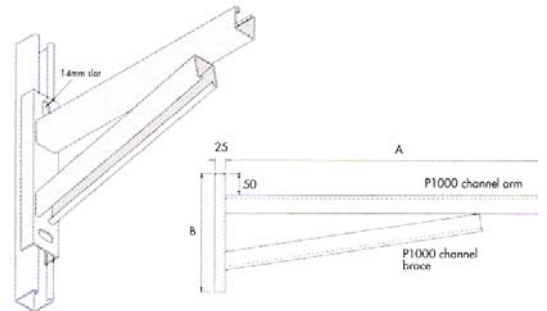

Two bolt fixing

P5665

	<i>A mm</i>	<i>Recommended UDL Kgf</i>	<i>Wt. Each Kg.</i>
P5665 / 150	160	169	0.32
P5665 / 300	310	87	0.48
P5665 / 450	460	58	0.63
P5665 / 600	610	44	0.78

Finishes : HG,

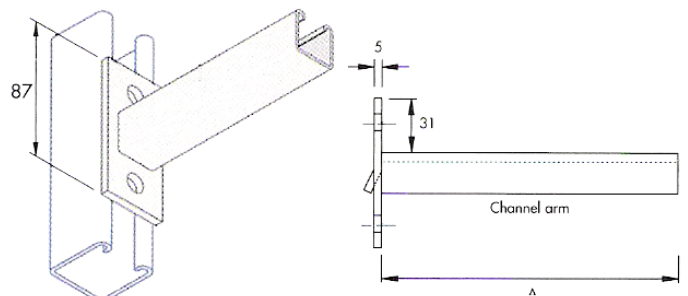

M5

Cantilever Arm for use with P1000 Channel.
Can be used in inverted position to that illustrated.
Single bolt fixing (top hole only required)

Traying Arms

P 2497R

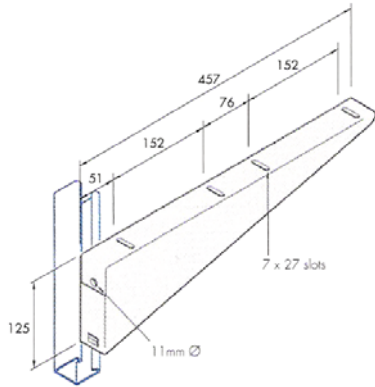

Finishes : PG , Wt. 1006g
U.D.L. on Brackets 110 Kgf

P2500R

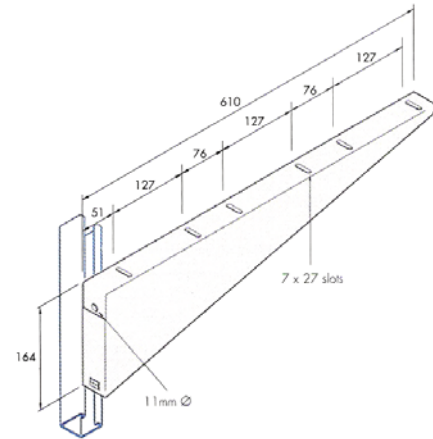

Finishes : PG , Wt. 1575g
U.D.L. on Brackets 100 Kgf

P2494R

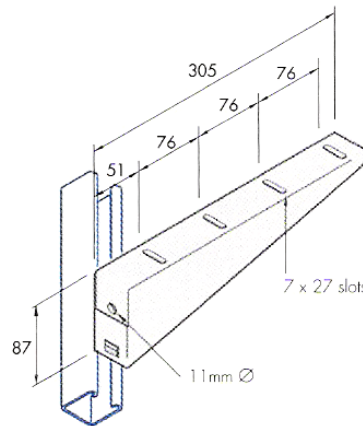

Finishes : PG , Wt. 580g
U.D.L. on Brackets 140 Kgf

P2491R

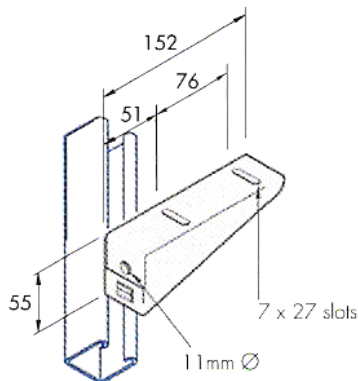

Finishes : PG , Wt. 247g
U.D.L. on Brackets 160 Kgf

P1075-8

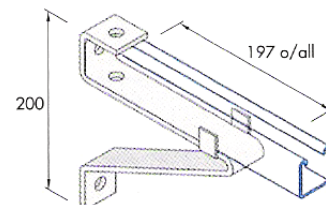

Suitable for P1000 / P2000
Design Moment (Nm) for Channel Indicted*
P1000 P2000
500 450

* Applies only to fittings and not strength of Unistrut Arm.

Finishes : HG , Wt. 1050g
Resisted Design No. 950703

Fluorescent Lighting Supports & Fittings.

Introduction

Unistrut provides an economical, adoptable and easily erected system of fluorescent trunking. Standard adaptors, which support most types of fluorescent lighting or tungsten fittings, can be fitted at any point along the channel length, thus facilitating the re-arrangement of lighting at any time. The adaptor, being hollow, also serves as a conduit for the electrical wiring between channel and fitting. Suspension of the system can be made from steel, timber or concrete structure by means of rods or beam clamps.

<i>Channel</i>	<i>Support Centers mm</i>	<i>Deflection (Aprox.) Center Span mm</i>	<i>End Spam (Approx.) Meters</i>
P4000	2500	8.8	0.6 – 0.8
P3300	2500	7.1	0.6 – 0.8
P2000	2500	1.7	0.6 – 0.8
P1000	2500	1.3	0.6 – 0.8
P2000	3000	3.3	0.8 – 1.0
P3301	3000	3.6	0.8 – 1.0
P1000	3000	2.5	0.8 – 1.0
P2000	3500	6.4	0.9 – 1.2
P3301	3500	7.0	0.9 – 1.2
P1000	3500	4.9	0.9 – 1.2
P2001	3500	1.5	0.9 – 1.2
P3301	4000	12.3	1.0 – 1.4
P1000	4000	8.6	1.0 – 1.4
P2001	4000	2.7	1.0 – 1.4
P1001	4000	2.3	1.0 – 1.4
P1000	4500	13.3	1.2 – 1.5
P2001	4500	4.2	1.2 – 1.5
P1001	4500	3.5	1.2 – 1.5
P2001	5000	6.1	1.4 – 1.7
P1001	5000	5.2	1.4 – 1.7
P1001	6000	1.7	1.5 – 1.8

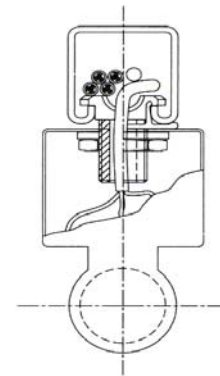
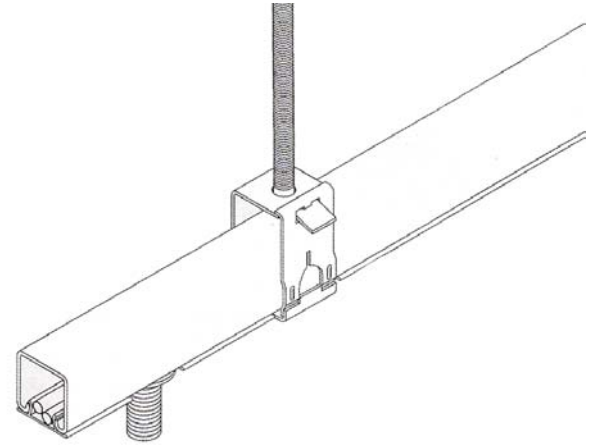

Typical Fluorescent Lighting Arrangement

Deflections are based on continuity of span assuming adequate lateral support and use of fixtures each weighing approximately 11.3 Kg and being 1524 mm long. Joiner fittings should be positioned at one quarter span between supporting hangers. With fixtures having 600mm spaces between them deflection is 70% - 80% of above table, with 1200 mm spaces between them deflection is 50% - 60% of above table.

Channel Accessories

P1200

Top Hat Section

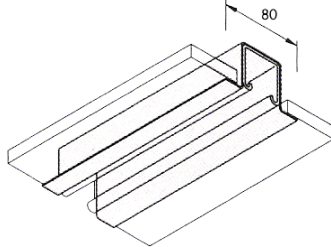

Finishes : PG, Length 3m, Wt. 1.5Kg/m

Support can be provided for ceiling panels by placing a length of steel "Top Hat" section over the trunking channel. On this visible metal ceiling framing most type of ceiling tile can be supported.

P6240

Trunking Connector

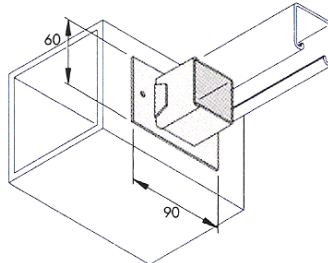

Finishes : ZP, Wt. 150g

Zinc-Plated steel fitting for joining channel sections to main trunking. Suitable for P1000, P2000, P3301 and P4001 trunking sections onl. One M6 x 20 hexagon head screw and one P3006 clamping nut required to connect channel to fitting.
N.B. Connections to main trunking not included

P1218

Internal Splice

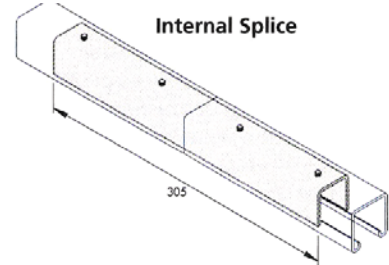

Finishes : ZP & SS, Wt. 539g

P1218 for use with P1000, P1001, P2000 and P2001 channel.

N.B. 4 No. M6 pan head fixing screws included.

P1220A

Two Way Junction Splice

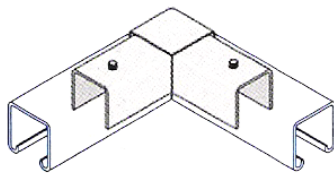

Finishes : ZP, Wt. 405g
N.B. 2 No. M6 PH fixing screws included

P1221A

Three Way Junction Splice

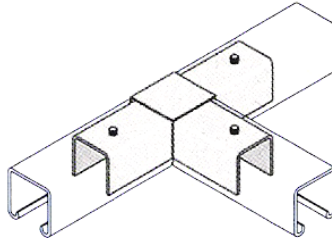

Finishes : ZP, Wt. 570g
N.B. 3 No. M6 PH fixing screws included

P1222A

Four Way Junction Splice

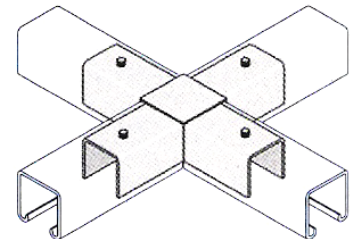

Finishes : ZP, Wt. 710g
N.B. 4 No. M6 PH fixing screws included

P1184-F

Closer Strip

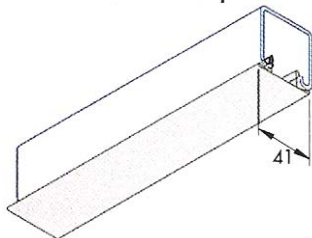

Finishes : PG, Length 3m, Wt. 0.36 Kg/m

P1184-P

Closer Strip

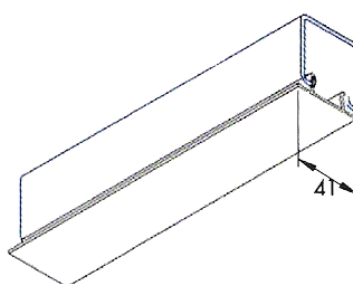

Finishes : White & Black PVC, Length 3m, Wt. 0.16 Kg/m

P2855

Hanger Fitting

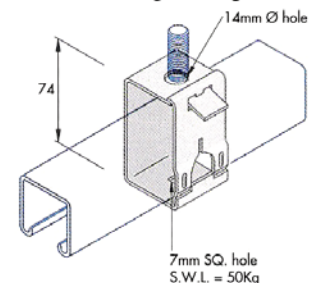

Finishes : ZP, Wt. 159g
N.B. Threaded rod ordered separately.
The Unistrut Snap-On two piece hanger fitting eliminates the need for nuts & bolts thus reducing on site installation time.

**P1/2240
End Cap**

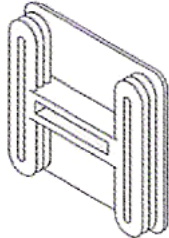

Finishes : White & black PVC , Wt. 5 g
For P1000 & P2000 & Combinations

**P3/4240
End Cap**

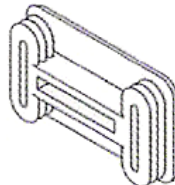

Finishes : White & black PVC , Wt. 3 g
For P3300 & P4000 & Combinations

**P2353-5
Eye Bolt**

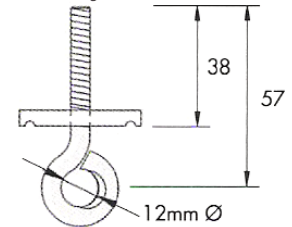

N.B. For suspension purposes M6 with 12mm inside diameter eye. Nut not included.

Finishes : ZP , Wt. 1.5 Kg/100
Recommended loading : 50 Kg static load.

**P2521/50 & 75
Conduit Connector**

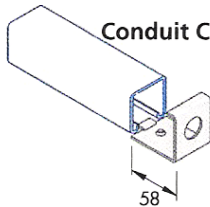

Finishes : ZP , Wt. 77g & 75 g respectively.

For use with P1000 / P2000

P2521/50 for use with 20mm conduit. Wt. 77g

P2521/75 for use with 25mm conduit. Wt. 75g

N.B. One M6 x 16 countersunk head screw and one P3006/M6 clamping nut should be ordered with each end connector.

**P2750/1
Nylon Roller & Carriage**

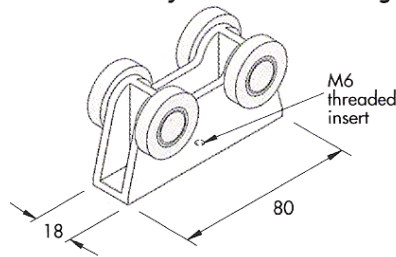

Finishes : Self Color White, Wt. 68g
Recommended Loading 40 Kg.
For use in P1000 channel

**P2749
Steel Roller & Carriage**

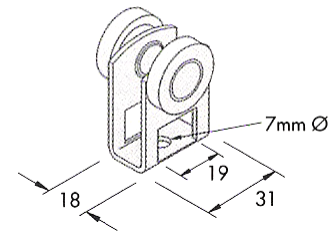

Finishes : ZP , Wt. 95 g
Approx design load 23 Kg.
For use in P1000 channel

**P2540 M20
Fluorescent Adaptor**

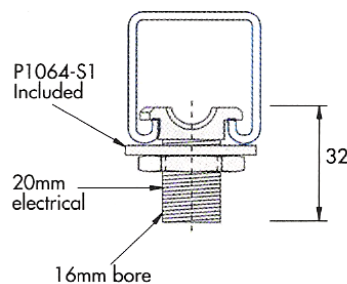

Finishes : Brass , Wt. 298 g

Simplifies attachment of fluorescent fittings to channel either direct or on droppers of 20mm conduit which is secured by a standard socket to male thread of adaptor. Wiring runs from channel through center hole of adaptor

N.B. P1064-S1 included.

Pipe Supports & Fittings

Introduction

In conjunction with Unistrut metal framing, Unistrut pipe supports and fittings offer the complete solution to pipe clamps, guides, rollers and hangers.

Designed to fit all Unistrut channels and inserts, the fittings can also be fixed to existing steelwork, brickwork or concrete structures.

Range

Products are available to accommodate both copper and steel pipes.

Finishes

Standard finish in zinc electroplated and nylon coated for isolation when used with copper pipes. Stainless steel can be supplied to special order.

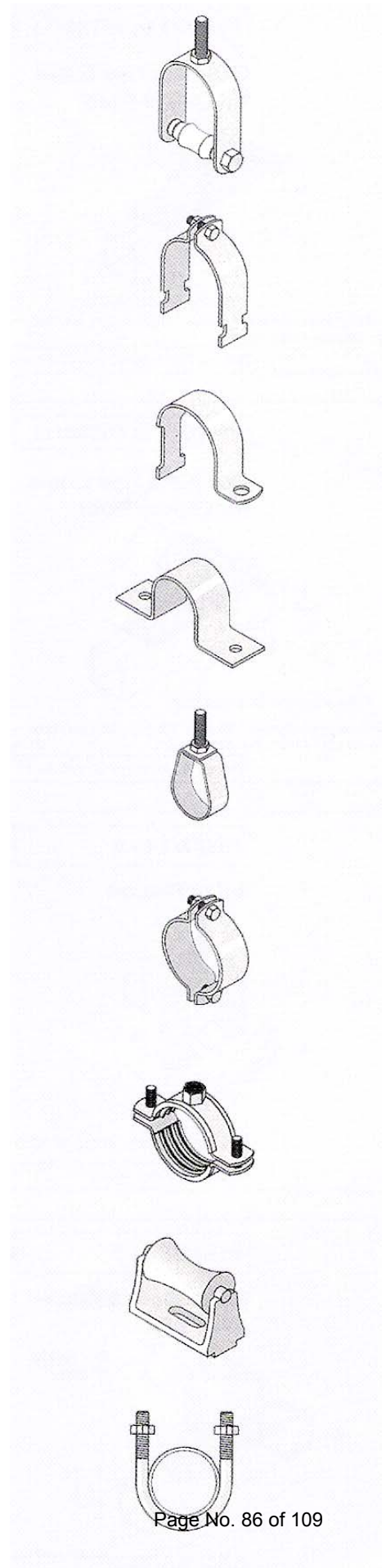

Pipe Supports & Fittings – Copper Pipes

P5799/1 to P5799/11

Part No.	Pipe size A mm	B mm	Material size mm	Hole size mm	Weight each g
P5799/1*	15	84	25 x 3	8	60
P5799/2*	22	96	25 x 3	8	70
P5799/3*	28	99	25 x 3	8	80
P5799/4*	35	107	25 x 3	8	90
P5799/5	42	134	30 x 3	11	140
P5799/6	54	146	30 x 3	11	170
P5799/7	66	180	40 x 3	14	250
P5799/8	76	188	40 x 3	14	300
P5799/9	108	224	40 x 3	14	350
P5799/10	133	258	40 x 5	14	650
P5799/11	159	278	40 x 5	14	850

One Piece Pipe Guide for Copper Pipes

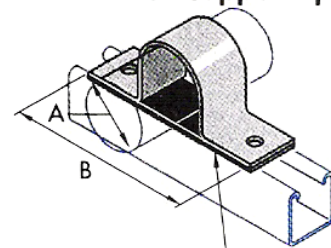

Polypropylene isolation strip

2mm to 3mm clearance for pipe.

Adaptor plate supplied for use with 41mm channels.

Finishes : Nylon coated color : Black

P5800/1 to P5800/11

Part No.	Pipe size A mm	B mm	Material size mm	Hole size mm	Weight each g
P5800/1*	15	78	25 x 3	8	60
P5800/2*	22	90	25 x 3	8	70
P5800/3*	28	93	25 x 3	8	80
P5800/4*	35	111	25 x 3	8	90
P5800/5	42	128	30 x 3	11	140
P5800/6	54	140	30 x 3	11	170
P5800/7	66	174	40 x 3	14	250
P5800/8	76	182	40 x 3	14	300
P5800/9	108	218	40 x 3	14	350
P5800/10	133	252	40 x 5	14	650
P5800/11	159	272	40 x 5	14	1200

One Piece Pipe Clamp for Copper Pipes

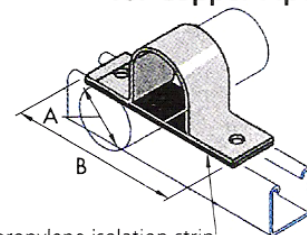

Polypropylene isolation strip

2mm to 3mm clearance for pipe.

Adaptor plate supplied for use with 41mm channels.

Finishes : Nylon coated color : Black

P5802/1 to 9

<i>Part No.</i>	<i>Pipe size A mm</i>	<i>B mm</i>	<i>C mm</i>	<i>Material size mm</i>	<i>Hole size mm</i>	<i>Weight each g</i>
P5802/1*	28	68	49	30 x 3	M10	225
P5800/2*	35	83	60	30 x 3	M10	250
P5802/3*	42	87	66	30 x 3	350.00	300
P5802/4*	54	102	66	30 x 3	M10	350
P5802/5	66	145	88	40 x 3	M12	500
P5802/6	76	155	98	40 x 3	M12	550
P5802/7	108	180	120	40 x 5	M12	950
P5802/8	133	229	150	50 x 6	M16	1900
P5802/9	159	253	180	50 x 6	M16	2100

Roller Bracket

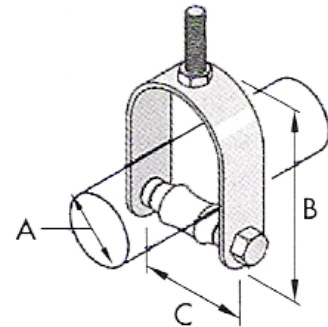

B = Top of fitting to top of roller
Finishes : ZP (roller : Nylon)

P5801/5 to 9

<i>Part No.</i>	<i>Pipe size A mm</i>	<i>B mm</i>	<i>C mm</i>	<i>D mm</i>	<i>Material size mm</i>	<i>Hole size mm</i>	<i>Weight each g</i>
P5801/5	66	35	118	179	40 X 3	14.00	1000
P5801/6	76	35	128	184	40 X 3	14.00	1100
P5801/7	108	35	159	218	40 X 3	14.00	1300
P5801/8	133	40	195	254	50 x 3	18.00	2300
P5801/9	159	40	227	282	50 x 3	18.00	2400

Roller Chair & Guide Assembly

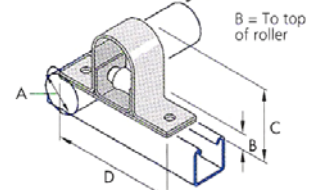

Finishes: Nylon coated, Color Black
(Roller : Nylon)

N.B. Any item with nylon associated has a maximum temperature rating of 100°C

Pipe Supports & Fittings – Steel Pipes

P1109 thru P1126

Part No.	Pipe Size		O.D. Size		Thickness		Weight/C		Design Load	
	In	Mm	In	Mm	Gage	Mm	Lbs	Kg	Lbs	kN
P1109	3/8		.625	17.1	16	1.5	10	4.5	400	1.8
P1111	1/2		.840	21.3	16	1.5	11	5.0	400	1.8
P1112	3/4		1.050	26.7	14	1.9	15	6.8	600	2.7
P1113	1		1.315	33.4	14	1.9	17	7.7	600	2.7
P1114	1 1/4		1.660	42.2	14	1.9	19	8.6	600	2.7
P1115	1 1/2		1.900	48.3	12	2.7	29	13.2	800	3.6
P1117	2		2.375	60.3	12	2.7	34	15.4	800	3.6
P1118	2 1/2		2.875	73.0	12	2.7	40	18.1	800	3.6
P1119	3		3.500	88.9	12	2.7	47	21.3	800	3.6
P1120	3 1/2		4.000	101.6	11	3.0	62	28.1	1000	4.4
P1121	4		4.500	114.3	11	3.0	67	30.4	1000	4.4
P1123	5		5.563	141.3	11	3.0	80	36.3	1000	4.4
P1124	6		6.625	168.3	10	3.4	102	46.3	1000	4.4
P1126	8		8.625	219.1	10	3.4	130	59.0	1000	4.4

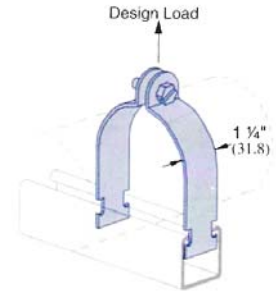

Slotted hex head screw & Nut included.

Finish : Electro-Galvanized.

P1425 thru P1431

Part No.	Pipe Size		O.D. Size		Thickness		Weight/C		Design Load	
	In	Mm	In	Mm	Gage	Mm	Lbs	Kg	Lbs	kN
P1425	3/8		.577	14.7	16	1.5	9	4.1	400	1.8
P1426	1/2		.706	17.9	16	1.5	11	5.0	400	1.8
P1427	3/4		.922	23.4	16	1.5	12	5.4	400	1.8
P1428	1		1.163	29.5	14	1.9	15	6.8	600	2.7
P1429	1 1/4		1.510	38.4	14	1.9	18	8.2	600	2.7
P1430	1 1/2		1.740	44.2	12	2.7	29	13.2	800	3.6
P1431	2		2.197	55.8	12	2.7	33	15.0	800	3.6
P1118	2 1/2		2.875	73.0	12	2.7	40	18.1	800	3.6
P1119	3		3.500	88.9	12	2.7	47	21.3	800	3.6
P1121	4		4.500	114.3	11	3.0	67	30.4	1000	4.4

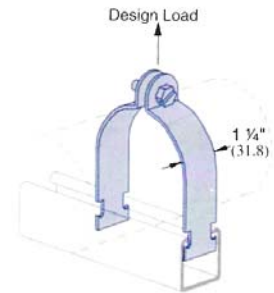

Slotted hex head screw & Nut included.

Finish : Electro-Galvanized.

P5792/1 to P5792/11

Part No.	Nom Bore mm	OD A mm	B mm	Material size mm	Hole size mm	Weight each g
P5792/1*	15	21	84	25 X 3	8.00	70
P5792/2*	20	27	95	25 X 3	8.00	80
P5792/3*	25	34	98	25 X 3	8.00	90
P5792/4	32	42	126	30 x 3	11.00	140
P5792/5	40	48	136	30 x 3	11.00	160
P5792/6	50	60	146	30 x 3	11.00	170
P5792/7	65	76	184	40 x 3	14.00	250
P5792/8	80	89	196	40 x 3	14.00	300
P5792/9	100	114	226	40 x 3	14.00	350
P5792/10	125	140	261	40 x 5	14.00	700
P5792/11	150	168	286	40 x 5	14.00	800

One Piece Pipe Guide for Steel Pipes

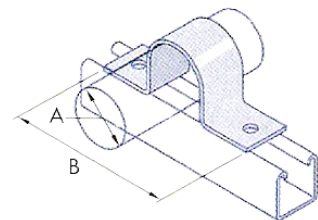

* Adaptor plate supplied for use with 41mm channels.

Finishes : ZP

P5798/1 to P5798/9

Part No.	Nom Bore mm	OD A mm	B mm	C mm	Material size mm	Dia Rod required	Weight Each g
P5798/1	25	34	77	50	30 X 5	M10	200
P5798/2	32	42	78	60	30 X 5	M10	200
P5798/3	40	48	82	65	30 X 5	M10	200
P5798/4	50	60	92	65	30 X 5	M10	200
P5798/5	65	76	109	85	40 X 5	M12	400
P5798/6	80	89	152	100	40 X 5	M12	500
P5798/7	100	114	181	120	50 X 6	M12	1000
P5798/8	125	140	198	165	50 X 6	M16	2000
P5798/9	150	168	236	188	50 X 6	M16	2500

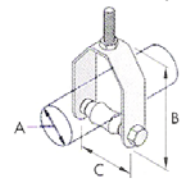
Single Roller Bracket for Steel Pipes

B = inside top to top of roller

Finishes : ZP (roller : Cast iron)

P5803/1 to P5803/11

Part No.	Nom Bore mm	OD A mm	B mm	Material size mm	Dia Rod required	Weight each g
P5803/1	15	21	38	22 X 0.9	M10	35
P5803/2	20	27	38	22 X 0.9	M10	37
P5803/3	25	34	38	22 X 1.2	M10	42
P5803/4	32	42	40	22 X 1.2	M10	45
P5803/5	40	48	50	22 X 1.2	M10	50
P5803/6	50	60	60	22 X 1.2	M10	62
P5803/7	65	76	80	30 X 1.6	M12	132
P5803/8	80	89	95	30 X 1.6	M12	150
P5803/9	100	114	110	30 X 1.6	M12	200
P5803/10	125	140	140	30 X 1.6	M12	230
P5803/11	150	168	150	30 X 2.0	M12	270

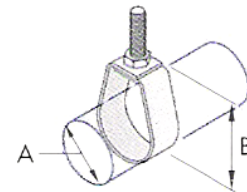
Filbow Clamp for Steel Pipes

B = inside top to center line of pipe

Finishes : ZP

P5790/1 to P5790/11

Part No.	Nom Bore mm	OD A mm	Material size mm	Hole size mm	Weight each g
P5790/1	15	21	25 X 3	8.00	120
P5790/2	20	27	25 X 3	8.00	130
P5790/3	25	34	25 X 3	8.00	140
P5790/4	32	42	30 x 3	12.00	260
P5790/5	40	48	30 x 3	12.00	290
P5790/6	50	60	30 x 3	12.00	330
P5790/7	65	76	40 x 3	12.00	430
P5790/8	80	89	40 x 3	12.00	460
P5790/9	100	114	40 x 3	14.00	610
P5790/10	125	140	40 x 5	14.00	1030
P5790/11	150	168	40 x 5	14.00	1130

Hanger Clamp for Steel Pipes

Eye bolts.
Order separately

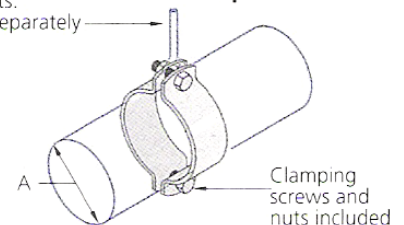

Finishes : ZP

P5791/1 to P5791/11

Part No.	Nom Bore mm	OD A mm	B mm	Material size mm	Hole size mm	Weight each g
P5791/1*	15	21	90	25 X 3	8.00	70
P5791/2*	20	27	101	25 X 3	8.00	80
P5791/3*	25	34	104	25 X 3	8.00	90
P5791/4	32	42	132	30 x 3	11.00	140
P5791/5	40	48	142	30 x 3	11.00	160
P5791/6	50	60	152	30 x 3	11.00	170
P5791/7	65	76	190	40 x 3	14.00	250
P5791/8	80	89	202	40 x 3	14.00	300
P5791/9	100	114	232	40 x 3	14.00	350
P5791/10	125	140	267	40 x 5	14.00	700
P5791/11	150	168	292	40 x 5	14.00	800

One Piece Pipe Guide for Steel Pipes

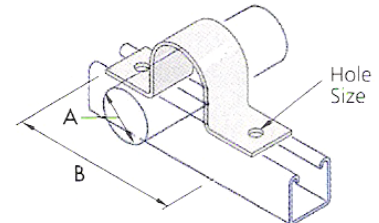

* Adaptor plate supplied for use with 41 mm channels.

Finishes ZP

P5797 A/O – A/7

Part No.	Pipe size Copper mm	Pipe size Steel mm	H mm	Weight each g
P5797 A/0	15		28	146
P5797 A/1	22	15 NB	32	190
P5797 A/2	28	20 NB	35	195
P5797 A/3	35	25 NB	39	195
P5797 A/4	42	32 NB	43	215
P5797 A/5	–	40 NB	46	215
P5797 A/6	54		48	235
P5797 A/7	–	50 NB	53	235

Roller Chair and Guide Assembly for Copper and Steel Pipes

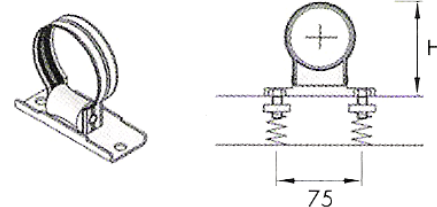

Finishes: Cradle – ZP, Guide – Black epoxy paint, Roller – Black polyether-Sulphone. Max. temp rating 200°C

P5807/1 to P5807/13

Boss Tapped M10			
Part No.	O. Dia		Weight each g
	Min mm	Max mm	
P5807/1	20	25	61
P5807/2	26	30	71
P5807/3	31	38	77
P5807/4	40	47	86
P5807/5	46	53	99
P5807/6	58	68	103
P5807/7	65	71	108
P5807/8	72	80	174
P5807/9	81	93	199

Clamp Without Lining

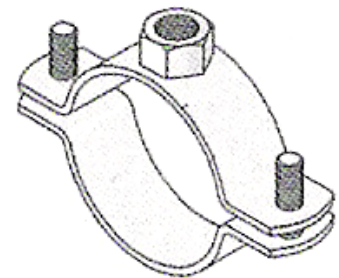

Finishes: ZP & SS

Boss Tapped M12			
Part No.	O.Dia		Weight each g
	Min mm	Max mm	
P5807/10	111	115	259
P5807/11	125	128	210
P5807/12	135	142	288
P5807/13	165	172	352

P5808/1 to P5808/18

Boss Tapped M10			
Part No.	O. Dia		Weight each g
	Min mm	Max mm	
P5808/1	14	20	84
P5808/2	20	26	92
P5808/3	25	32	104
P5808/4	32	39	115
P5808/5	40	47	123
P5808/6	48	54	140
P5808/7	54	60	127
P5808/8	57	64	158
P5808/9	68	72	234
P5808/10	72	80	264
P5808/11	82	86	280
P5808/12	88	92	288
P5808/13	108	112	370

Clamp with Lining

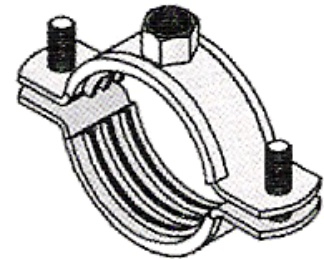

Finishes ZP & SS

Boss Tapped M12			
Part No.	O. Dia		Weight each g
	Min mm	Max mm	
P5808/14	112	118	347
P5808/15	133	137	438
P5808/16	137	142	418
P5808/17	159	162	468
P5808/18	164	168	457

P5818/1 to P5818/9

Boss Tapped M10			
Part No.	O. Dia		Weight each g
	Min mm	Max mm	
P5818/1	13	15	353
P5818/2	16	18	371
P5818/3	20	22	425
P5818/4	25	28	480
P5818/5	33	35	544
P5818/6	42	44	615
P5818/7	48	50	654
P5818/8	52	55	745
P5818/9	60	62	799

Hinged Clamp With Lining

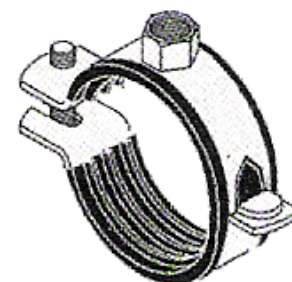

Finished : ZP

Beam Clamps, Pipe Clamps & Pipe Hangers

C-720

Dimensions Inches/ (mm) – Weights - Loads

Pipe Size	A	Stock Size	Bolt Size	Wt./C lbs.(kg.)	Design Load lbs. (Kn)
1/2 (13)	9-1/4 (235)	3/16 x 1-1/4 (5 x 32)	3/8 x 1-1/2 (9.5 x 38)	138 (62.6)	255 (1.1)
3/4 (19)	9-1/4 (235)	3/16 x 1-1/4 (5 x 32)	3/8 x 1-1/2 (9.5 x 38)	138 (62.6)	255 (1.1)
1 (25.4)	9-9/16 (243)	3/16 x 1-1/4 (5 x 32)	3/8 x 1-1/2 (9.5 x 38)	140 (63.5)	255 (1.1)
1-1/4 (32)	9-11/16 (246)	3/16 x 1-1/4 (5 x 32)	3/8 x 1-1/2 (9.5 x 38)	150 (68)	255 (1.1)
1-1/2 (38)	10-3/8 (263.5)	3/16 x 1-1/4 (5 x 32)	3/8 x 1-1/2 (9.5 x 38)	155 (70)	255 (1.1)
2 (51)	10-3/4 (273)	3/16 x 1-1/4 (5 x 32)	3/8 x 1-1/2 (9.5 x 38)	160 (72.5)	255 (1.1)
2-1/2 (63.5)	11-3/8 (290)	1/4 x 1-1/4 (6 x 32)	3/8 x 1-1/2 (9.5 x 38)	225 (102)	390 (1.7)
3 (76)	12 (305)	1/4 x 1-1/4 (6 x 32)	3/8 x 1-1/2 (9.5 x 38)	250 (113.4)	530 (2.4)
3-1/2 (89)	13 (330)	1/4 x 1-1/4 (6 x 32)	3/8 x 1-1/2 (9.5 x 38)	265 (120)	670 (3.0)
4 (101.6)	13-1/2 (343)	1/4 x 1-1/4 (6 x 32)	1/2 x 1- 1/2 (13 x 38)	330 (149.6)	810 (3.6)
5 (127)	14-1/2 (368)	1/4 x 1-1/4 (6 x 32)	1/2 x 1- 1/2 (13 x 38)	365 (165.5)	1160 (5.2)
6 (152.4)	15-1/2 (384)	1/4 x 2 (6 x 51)	1/2 x 1- 1/2 (13 x 38)	410 (186)	1570 (7.0)
8 (203)	18-1/2 (470)	3/8 x 2 (9.5 x 61)	5/8 x 2- 1/2 (16 x 63.5)	695 (315)	2500 (11.1)
10 (254)	20-3/4 (527)	3/8 x 2 (9.5 x 61)	5/8 x 2- 1/2 (16 x 63.5)	1150 (521.5)	2500 (11.1)
12 (304)	22-3/4 (578)	3/8 x 2 (13 x 61)	5/8 x 2- 1/2 (16 x 63.5)	1800 (816)	2700 (12)

Raiser Clamp

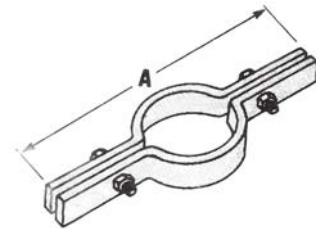

Complies with Federal Spec.
WW-H-171E & SP-69, Type 8

Note: Load rating based on case iron soil pipe Load rating for other pipe may vary depending on co-efficient friction of pipe surface.

C720L

Dimensions Inches – Weights - Loads

Pipe Size	A	B	Hole Size	Stock Size	Wt./C lbs.(kg.)	Design Load lbs. (Kn)
3/4 (19)	5-15/16 (151)	2-1/2 (63.5)	7/16 (11)	3/16 x 1-1/4 (5 x 32)	109 (49.4)	300 (1.3)
1 (25.4)	6-1/4 (159)	2-5/8 (67)	7/16 (11)	3/16 x 1-1/4 (5 x 32)	116 (52.6)	300 (1.3)
1-1/4 (32)	6-11/16 (170)	2-3/4 (70)	7/16 (11)	3/16 x 1-1/4 (5 x 32)	126 (57)	300 (1.3)
1-1/2 (38)	6-15/16 (176)	3 (76)	7/16 (11)	3/16 x 1-1/4 (5 x 32)	134 (61)	300 (1.3)
2 (51)	8-5/16 (211)	3-3/16 (81)	7/16 (11)	1/4 x 1-1/4 (6.4 x 32)	191 (86.6)	500 (2.2)
2-1/2 (63.5)	8-7/8 (225.4)	3-7/16 (87)	7/16 (11)	1/4 x 1-1/4 (6.4 x 32)	209 (95)	500 (2.2)
3 (76)	9-1/2 (241)	3-3/4 (95)	7/16 (11)	1/4 x 1-1/4 (6.4 x 32)	232 (105)	500 (2.2)
3-1/2 (89)	10-1/16 (255.6)	4 (101.6)	7/16 (11)	1/4 x 1-1/4 (6.4 x 32)	250 (113)	500 (2.2)
4 (101.6)	10-9/16 (268)	4-1/4 (108)	9/16 (14)	1/4 x 1-1/2 (6.4 x 38)	327 (148)	600 (2.6)
5 (127)	11-11/16 (297)	4-3/4 (121)	9/16 (14)	1/4 x 1-1/2 (6.4 x 38)	380 (172)	600 (2.6)
6 (152)	14-3/8 (365)	5-5/16 (135)	9/16 (14)	3/8 x 1-1/2 (9.5 x 38)	650 (295)	850 (3.8)
8 (203)	16-5/8 (422)	6-5/16 (160)	9/16 (14)	3/8 x 1-1/2 (9.5 x 38)	787 (357)	850 (3.8)

Offset Pipe Clamp Steel

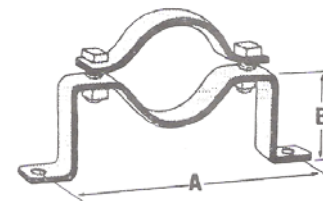

Clamp design permits pipe to be held away from mounting surface. Top Clamp, bottom support and two bolts with nuts – assembled.

Order By Prod. #, pipe size.

For Variation in “B” dimension, consult factory.

C-710

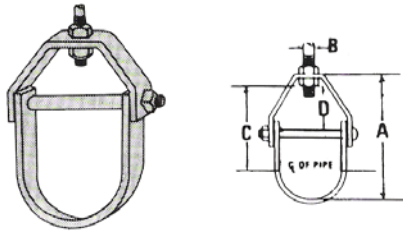

Adjustable Clevis Hanger

Complies with Federal Spec. WW-H-171E and Sp-69, Type 1.

Order by Prod. # and pipe Size

Dimensions Inches/ (mm) – Weights - Loads

Pipe Size	A	B	C	D	Bolt Size	Top Stock	Bottom Stock	Wt./C lbs.(kg.)	Design Load lbs. (Kn)
1/2 (13)	2-7/8 (73)	3/8 (10)	1-3/16 (30)	1 (25.4)	1/4 x 2 (6 x 51)	1/8 x 1 (3 x 25.4)	1/8 x 1 (3 x 25.4)	32 (14)	610 (2.7)
3/4 (19)	3-1/16 (78)	3/8 (10)	1-7/8 (47.6)	1 (25.4)	1/4 x 2 (6 x 51)	1/8 x 1 (3 x 25.4)	1/8 x 1 (3 x 25.4)	36 (10)	610 (2.7)
1 (25.4)	3-3/8 (86)	3/8 (10)	2-1/16 (52.4)	1 (25.4)	1/4 x 2 -1/4 (6 x 57)	1/8 x 1 (3 x 25.4)	1/8 x 1 (3 x 25.4)	40 (18)	610 (2.7)
1-1/4 (32)	3-3/4 (95)	3/8 (10)	2-1/4 (57)	1 (25.4)	1/4 x 2-1/4 (6 x 57)	1/8 x 1 (3 x 25.4)	1/8 x 1 (3 x 25.4)	44 (20)	610 (2.7)
1-1/2 (38)	4-1/16 (103)	3/8 (10)	2-3/8 (60)	1 (25.4)	1/4 x 2-3/4 (6 x 70)	1/8 x 1 (3 x 25.4)	1/8 x 1 (3 x 25.4)	48 (22)	610 (2.7)
2 (51)	4-1/2 (114)	3/8 (10)	2-3/4 (69.4)	1 (25.4)	1/4 x 3-1/4 (6 x 82.5)	1/8 x 1 (3 x 25.4)	1/8 x 1 (3 x 25.4)	55 (25)	610 (2.7)
2-1/2 (63.5)	5-1/2 (140)	1/2 (13)	3-1/4 (82.5)	1 (25.4)	3/8 x 4-1/2 (10 x 114)	3/16 x 1-1/4 (5 x 32)	3/16 x 1-1/4 (5 x 32)	118 (53)	1130 (5.0)
3 (76)	6-1/8 (155.6)	1/2 (13)	3-1/2 (89)	1-1/4 (32)	3/8 x 5-1/4 (10 x 113)	3/16 x 1-1/4 (5 x 32)	3/16 x 1-1/4 (5 x 32)	130 (59)	1130 (5.0)
3-1/2 (89)	6-3/4 (171.5)	1/2 (13)	3-3/4 (95)	1-1/4 (32)	3/8 x 5-3/4 (10 x 146)	3/16 x 1-1/4 (5 x 32)	3/16 x 1-1/4 (5 x 32)	160 (72)	1130 (5.0)
4 (101.6)	7-5/8 (193.4)	5/8 (16)	4- 1/4 (108)	1-1/2 (38)	3/8 x 6-1/4 (10 x 159)	1/4 x 1-1/4 (6 x 32)	3/16 x 1-1/4 (5 x 32)	175 (79)	1430 (6.4)
5 (127)	8-7/8 (225.4)	5/8 (16)	5- 1/4 (133.4)	1-1/2 (38)	1/2 x 7-1/2 (13 x 190.5)	1/4 x 1 (6 x 25.4)	3/16 x 1-1/4 (5 x 32)	230 (104)	1430 (6.4)
6 (152.4)	10 (254)	5/8 (16)	5- 1/2 (140)	1-1/2 (38)	1/2 x 8-1/2 (13 x 216)	1/4 x 1-1/2 (6 x 38)	3/16 x 1-1/2 (5 x 38)	320 (145)	1430 (6.4)
8 (203)	12-3/4 (323)	7/8 (22)	7-1/8 (101)	2 (51)	5/8 x 11 (16 x 279.4)	1/4 x 1-1/2 (6 x 38)	3/16 x 1-1/2 (5 x 38)	450 (204)	1940 (8.6)
10 (254)	17-1/8 (435)	7/8 (22)	11-1/8 (282.5)	3-1/4 (82.5)	3/4 x 13.1/2 (19 x 343)	3/8 x 1-3/4 (10 x 44.4)	1/4 x 1-3/4 (6 x 44.4)	1060 (480)	3600 (16)
12 (304)	18-5/8 (473)	7/8 (22)	11-5/8 (295)	3-1/2 (89)	3/4 x 15-3/4 (19 x 400)	3/8 x 2 (10 x 51)	1/4 x 2 (6 x 51)	1284 (582)	3800 (16)

CL710

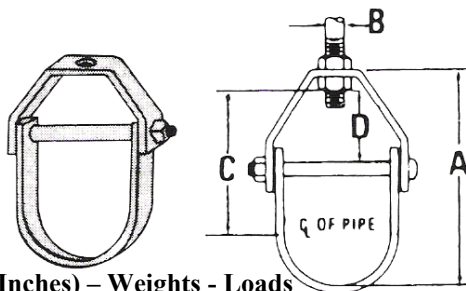

Light Duty Adjustable Clevis

Use on non-insulated stationary pipe lines. A lock nut above the clevis yoke is required to assure full rated load. Complies with Federal Spec. WW-H-171E and SP-69 Type 12.

Order by Prod. # and Pipe Size.

Dimensions Inches) – Weights - Loads

Pipe Size	A	B	C	D	Bolt Size	Top Stock	Bottom Stock	Wt./C lbs.(kg.)	Design Load lbs. (Kn)
2-13/16 (71.4)	3/8 (10)	1-3/16 (30)	1 (25.4)	1/4 x 2 (6 x 51)	13 ga x 7/8 (2.4 x 22)	13 ga x 7/8 (2.4 x 22)	20 (9.0)	150 (0.7)	
3/4 (19)	3 (76)	3/8 (10)	1-7/8 (47.6)	1 (25.4)	1/4 x 2 (6 x 51)	13 ga x 7/8 (2.4 x 22)	13 ga x 7/8 (2.4 x 22)	22 (10.0)	250 (1.1)
1 (25.4)	3-5/16 (84)	3/8 (10)	2-1/16 (52.4)	1 (25.4)	1/4 x 2 -1/4 (6 x 57)	13 ga x 7/8 (2.4 x 22)	13 ga x 7/8 (2.4 x 22)	24 (11)	250 (1.1)
1-1/4 (32)	3-13/16 (84)	3/8 (10)	2-1/4 (57)	1 (25.4)	1/4 x 2-1/4 (6 x 57)	13 ga x 7/8 (2.4 x 22)	13 ga x 7/8 (2.4 x 22)	26 (12)	250 (1.1)
1-1/2 (38)	4 (101.6)	3/8 (10)	2-3/8 (60)	1 (25.4)	1/4 x 2-3/4 (6 x 70)	13 ga x 7/8 (2.4 x 22)	13 ga x 7/8 (2.4 x 22)	28 (12)	250 (1.1)
2 (51)	4-7/16 (114)	3/8 (10)	2-3/4 (69.4)	1 (25.4)	1/4 x 3-1/4 (6 x 82.5)	13 ga x 7/8 (2.4 x 22)	13 ga x 7/8 (2.4 x 22)	35 (12)	250 (1.1)
2-1/2 (63.5)	5-3/8 (136.5)	1/2 (13)	3-1/4 (82.5)	1 (25.4)	3/8 x 4-1/2 (10 x 114)	1/8 x 1-1/4 (3 x 32)	1/8 x 1-1/4 (3 x 32)	92 (42)	350 (1.5)
3 (76)	6 (152.4)	1/2 (13)	3-1/2 (89)	1-1/4 (32)	3/8 x 5-1/4 (10 x 113)	1/8 x 1-1/4 (3 x 32)	1/8 x 1-1/4 (3 x 32)	95 (43)	350 (1.5)
3-1/2 (89)	6-5/8 (168)	1/2 (13)	3-3/4 (95)	1-1/4 (32)	3/8 x 5-3/4 (10 x 146)	1/8 x 1-1/4 (3 x 32)	1/8 x 1-1/4 (3 x 32)	114 (52)	350 (1.5)
4 (101.6)	7-1/2 (190.5)	5/8 (16)	4- 1/4 (108)	1-1/2 (38)	3/8 x 6-1/4 (10 x 159)	3/16 x 1-1/4 (5 x 32)	1/8 x 1-1/4 (3 x 32)	140 (63.5)	400 (1.7)

Pipe Supports & Fittings – Hydraulic Pipes

P2119F-30

Cast Iron Chair & Roller

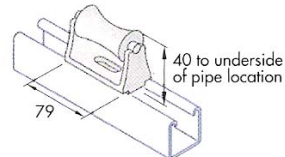

Pipe roller for pipes up to 100mm OD Order M10 x 25 mm hex screw, M10 flat washer and P3008 / M10 clamping nut separately
Wt. 370g each

P2119B-30

Cast Iron Chair & Brass Roller

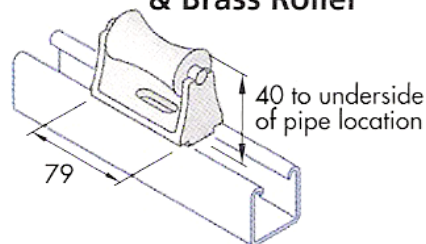

Pipe roller for pipes up to 100mm OD Order M10 x 25 mm hex screw, M10 flat washer and P3008 / M10 clamping nut separately
Wt. 400g each

P5797

Single Roller & Chair

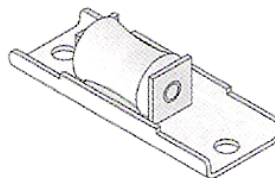

Suitable for copper pipes 15 – 54 mm / Steel pipes 15 – 50.
NB Msx. Temp rating = 200°C
Finishes: Chair ZP, Roller Black Polyethersulphone. Wt. 130g each.

P5797/5 to P5797/9

Part No.	Nom Bore mm	Outside Diameter				Material size mm	Hole size mm	Weight each g
		A mm	B mm	C mm	D mm			
P5797/5	65	76	43	128	179	40 X 5	14.00	1200
P5797/6	80	89	43	137	218	40 X 5	14.00	1500
P5797/7	100	114	43	163	218	40 X 5	14.00	1600
P5797/8	125	140	58	205	282	50 X 6	18.00	3200
P5797/9	150	168	58	239	282	51 X 6	18.00	3300

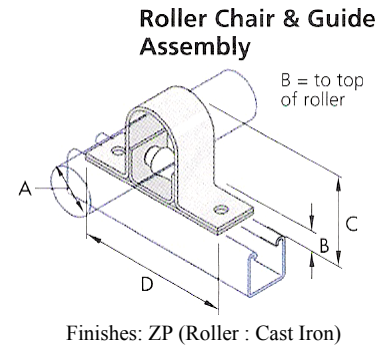

P2119F

Steel Brackets with Cast Iron Rollers*

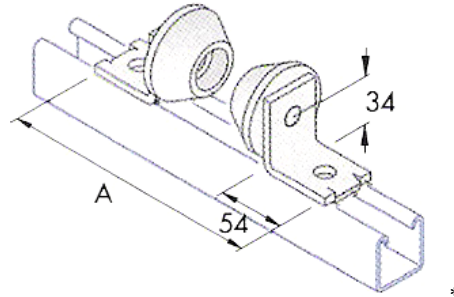

P2119B (Steel Brackets with brass roller)

Aprox Dimension A	For OD pipe size
200	114
225	140 – 168
250	219

Pipe roller set for 100mm to 220mm OD pipes. Max dia of roller 64 mm
 Finishes : Bracket – ZP, Wt. 1.15 Kg pair

P2119F-5 & P2119F-6

Steel Brackets with Cast Iron Rollers

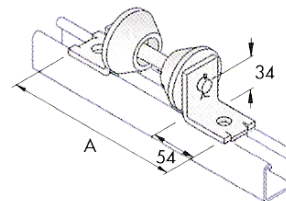

P2119B 5 & P2119B-6 (Steel Brackets with brass roller)

P2119F-5 & P2119B-5
 Pipe Roller assembly for 220mm to 275mm OD pipes..

P2119F-6 and P2119B-6
 Pipe roller assembly for 275mm to 325mm OD pipes.

Diameter

P2119/5	268mm
P2119/6	287mm

Max dia of roller 64 mm

Finishes : Bracket & Spindle ZP, Wt. 1.56 Kg & 1.58 Kg respectively.

P5814/1 to P5814/26

Part No.	Clip Bored		Suitable Pipe Sizes		L	W	H	C	G	Fixing	Wt. Each G
	Mm	Ins	OD	BSP							
P5814/1	6	0.236	1/4"		37	19	24	24	1	M6	10
P5814/2	8	0.315	5/6"		37	19	24	24	1	M6	10
P5814/3	10	0.394	3/8"	1/8"	37	19	24	24	1	M6	10
P5814/4	12	0.472			37	19	24	24	1	M6	10
P5814/5	13	0.511	1/2"		37	19	24	24	1	M6	18
P5814/6	14	0.551		1/4"	46	19	34	33	1	M6	18
P5814/7	16	0.630	5/8"		46	19	34	33	1	M6	18
P5814/8	17	0.669		3/8"	46	19	34	33	1	M6	18
P5814/9	19	0.748	3/4"		46	19	34	33	1	M6	18
P5814/10	21	0.827		1/2"	46	19	34	33	1	M6	18
P5814/11	22	0.866	7/8"		46	19	34	33	1	M6	18
P5814/12	25	0.984	1"		62	19	47	44	1	M8	27
P5814/13	27	1.063		3/4"	62	19	47	44	1	M8	27
P5814/14	30	1.181			62	19	47	44	1	M8	27
P5814/15	32	1.259	1 1/4"		62	19	47	44	1	M8	27
P5814/16	34	1.338		1"	79	19	66	61	1 1/2	M8	50
P5814/17	38	1.496	1 1/2"		79	19	66	61	1 1/2	M8	50
P5814/18	42	1.653		1 1/4"	79	19	66	61	1 1/2	M8	50
P5814/19	48	1.890	1 7/8"	1 1/2"	79	19	66	61	1 1/2	M8	50
P5814/20	51	2.007	2"		161	25	97	94	2	M10	120
P5814/21	60	2.363		2"	161	25	97	94	2	M10	120
P5814/22	64	2.519	2 1/2"		161	25	97	94	2	M10	110
P5814/23	76	2.993	3"	2 1/2"	161	25	97	94	2	M10	90
P5814/24	89	3.504	3 1/2"	3"	163	32	149	138	2	M12	290
P5814/25	102	4.016	4"	3 1/2"	163	32	149	138	2	M12	260
P5814/26	114	4.488	4 1/2"	4"	163	32	149	138	2	M12	240

Standard Clamp

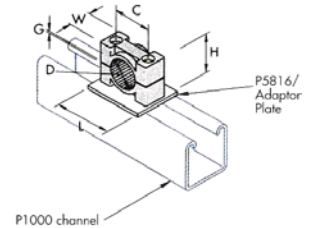

Order P5816 when used in conjunction with 41mm wide channel.

Finishes : Glass fiber filled polypropylene s/c gray.

P5816/1 to P5816/6

Part No.	L	C	Hole size mm	Weight each g	Use with
P5816/1	40	24	8	30	P5814/1-5
P5816/2	50	33	8	38	P5814/6-11
P5816/3	65	44	10	48	P5814/12-15
P5816/4	80	61	10	60	P5814/16-19
P5816/5	120	94	12	90	P5814/20-23
P5816/6	170	138	14	128	P5814/24-26

Adaptor Plate

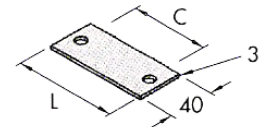

Finishes : ZP

P5815/1 to P5815/26

Part No.	Top Plate				Bottom Plate		Bolts mm	Weight each g
	A mm	B mm	C mm	D mm	E mm	F mm		
P5815/ 1 to 5	38	20	6	38	25	10	6 x 30	120
P5815/ 6 to 11	48	20	6	48	25	10	6 x 40	180
P5815/ 12 to 15	62	20	6	62	25	10	8 x 60	270
P5815/ 16 to 19	80	20	6	80	30	15	8 x 80	320
P5815/ 20 to 23	118	30	10	118	30	15	10 x 110	820
P5815/ 24 to 26	166	30	10	166	40	15	12 x 160	1670

Heavy Duty Clamp

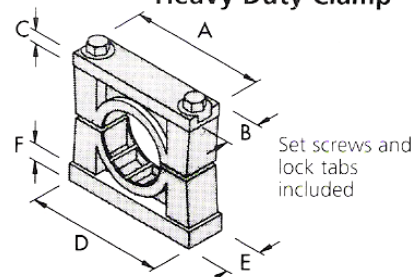

Pipe Supports & Fittings – Accessories

Rubber Profile Strip

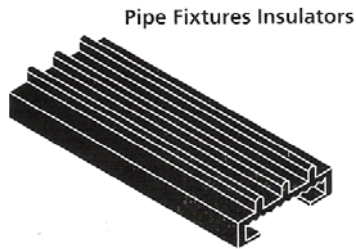

No moisture absorption, Resistant against weather, ozone, dilute acids & alkaline.

Limited resistance against grease and mineral oils.

Suitable for temper range -50° to $+120^{\circ}\text{C}$

Can be supplied separately in a variety of sizes for specialist application.

P2600

For use with 'M' series & SS2 series pipe clamps and others up to to 32 mm wide.

Note : When using Uni-Cushion in conjunction with Unistrut pipe clamps add 3mm to outside diameter of pipe.

Uni-Cushion give these positive advantages:-

Shock absorption.

Protection from corrosion and abrasion.

Allowance for expansion & contraction.

Isolation from sound and vibration.

Stability from -46°C to $+177^{\circ}\text{C}$

Supplied in cartons containing 8m.

Uni-Cushion

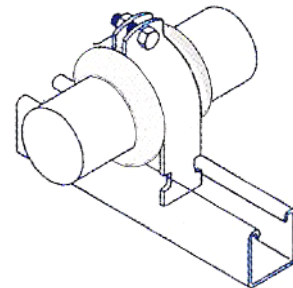

Color – Black , Wt. 1.25 kg.

Rapid Positioning Clip

The one piece pipe clip for easy installation of air conditioning pipe work to Unistrut metal framing channels.

The secure, but non-tightening design insulates the whole pipe thus eliminating condensation problems, movement of the pipe.

Installation times and costs are greatly reduced due to the simplicity and ease of installation, it simply twist into the channel and the pipe clips securely into position.

Available to suit pipe eyes from $3/8$ "to $1 1/8$ ".

Manufactured from composite polyamide, tested for use between -40° to 140°C .

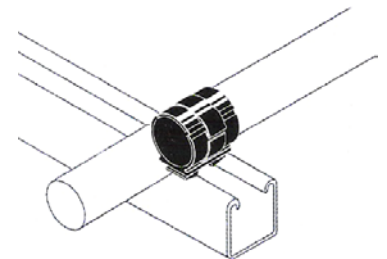

P5810/1 to P5810/3

<i>Part No.</i>	<i>Size</i>	<i>Weight each g</i>
P5810/1	M8 x 50	1.18
P5810/2	M10 x 60	1.41
P5810/3	M12 x 70	2.45

Threaded Rod LH/RH



Finishes : ZP

P5809/1 to P5809/3

<i>Part No.</i>	<i>Size</i>	<i>Adjusting reach</i>	<i>Weight each g</i>
P5809/1	M8 x 50	30	2.1
P5809/2	M10 x 60	30	2.8
P5809/3	M12 x 70	40	5.1

Turnbuckle LH/RH

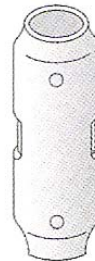

Finishes : ZP

P5806

<i>Part No.</i>	<i>Weight each g</i>
P5806-M6	0.75
P5806-M10	1.00
P5806-M12	2.00
P5806-M16	4.00

Rocker Nuts

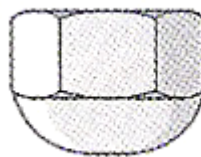

Finishes : Brass

P5811/14 to P5811/3

<i>Part No.</i>	<i>Size</i>	<i>Max load kg</i>	<i>Weight each g</i>	<i>Thread Length L mm</i>
P5811/1	M8 Standard	240	24	9
P5811/2	M10 Standard	300	30	12
P5811/3	M12 Long	350	35	14

Hanger Rod Swivel

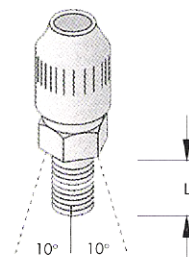

Finishes : ZP

P5793*/1-11 & P5794*/1-11

U Bolt Part No.	Nom Bore mm	A mm	B mm	B1 mm	C mm	C1 mm	D mm	Std mm	Extra gm
*/1	15	21	48	97	10	90	6	20	25
*/2	20	27	53	103	40	90	6	30	35
*/3	25	34	60	111	40	90	6	40	45
*/4	32	42	70	122	40	90	10	100	150
*/5	40	48	80	127	40	90	10	110	160
*/6	50	60	90	140	40	90	10	120	190
*/7	65	76	105	152	40	90	12	200	220
*/8	80	90	115	168	40	90	12	230	300
*/9	100	114	140	193	40	90	12	280	350
*/10	125	140	170	213	40	90	12	330	400
*/11	150	170	191	240	40	90	12	360	410

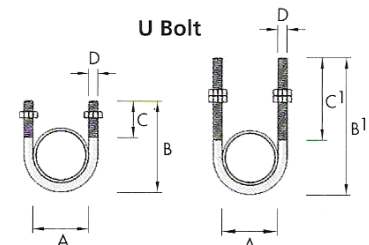

* Standard & Extended respectively.
Finishes : ZP

Eye Bolts

Eye Bolt Dia D	Dia B mm	Mm	Overall length A							
			mm	mm	mm	mm	mm	mm	mm	
M6	8	80	150	225	300	375	450	600	750	900
M10	12	80	151	225	300	375	450	600	750	900
M12	14	80	152	225	300	375	450	600	750	900
M16	16	80	153	225	300	375	450	600	750	900
M20	22	154	225	300	375	450	600	750	900	
M24	28					375	450	600	750	900

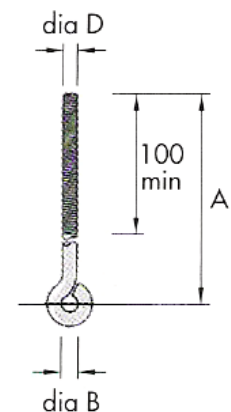

Finishes : ZP

Hexagon Rod Coupler

Coupling tapped right hand	Max Load kg	Weight each g
M6 x 25 HRC	109	12.5
M8 x 25 HRC	230	19
M8 x 30 HRC	230	23
M10 x 30 HRC	360	48
M10 x 40 HRC	360	56
M12 x 40 HRC	530	74
M12 x 50 HRC	530	74
M16 x 50 HRC	1010	120

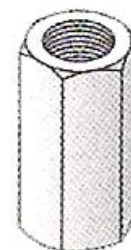

Finishes : ZP

Structural Connections

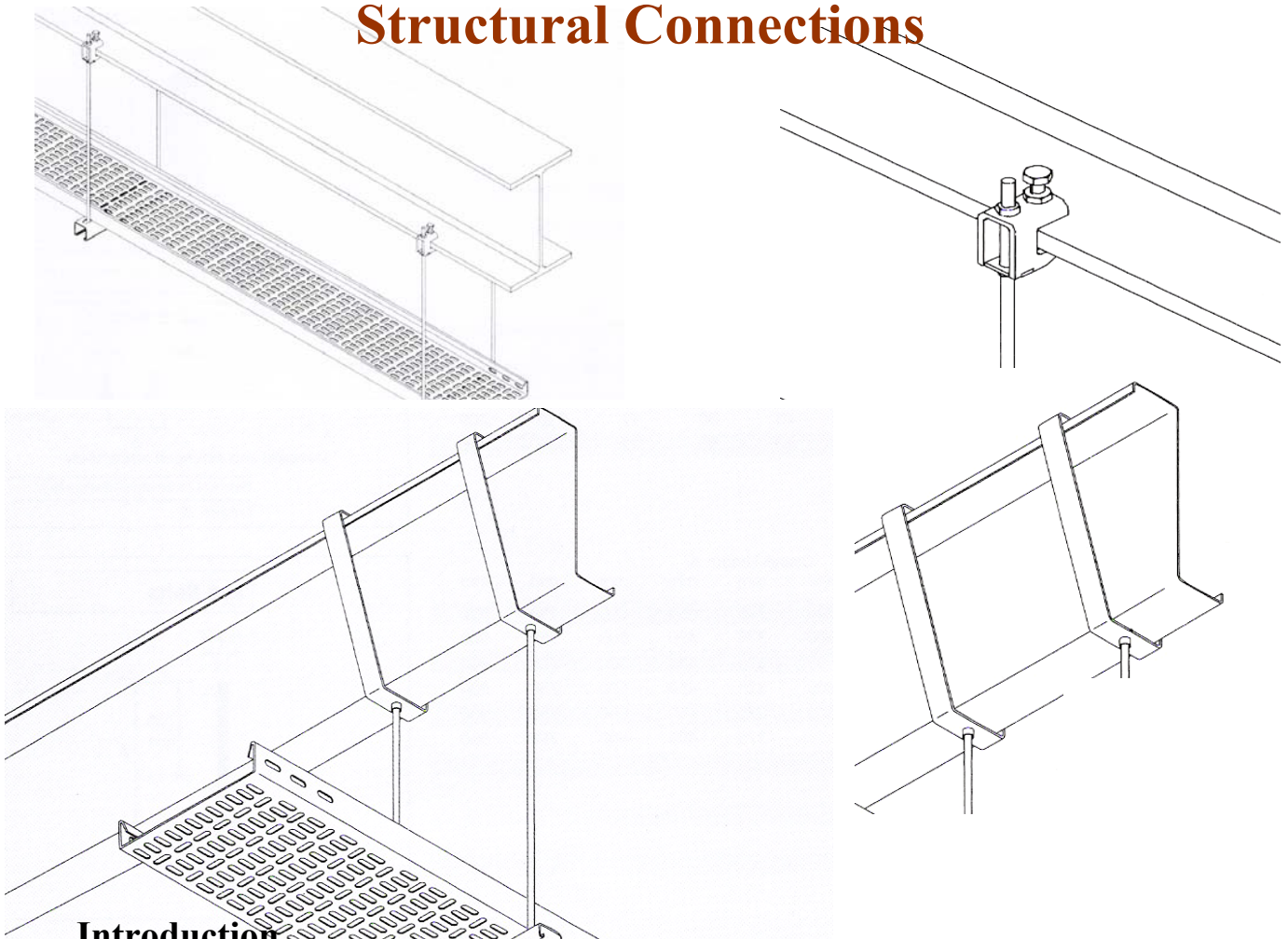

Introduction

To meet the demands of today's changing design and construction techniques, Unistrut manufacture and supply a range of products to connect metal framing systems to the structure. Connection to concrete substrates, whether new or existing, or securing secondary to primary steel work is easily achieved.

Concrete Substrates

To ensure structural integrity and ease of application, Unistrut concrete inserts, manufactured from the standard Unistrut section are recommended for use in new concrete. The unistrut connection principle is maintained enabling quick installation of fitting and accessories.

Steel Connections

The TUSC Universal Steel Connection is a highly advanced system for securing secondary to primary steelwork and other equipment and services to both without site welding or drilling.

TUSC draws on the benefits of modern metallurgy, advanced CAD design, computer stress analysis and extensive development and certification testing.

Concrete Inserts

The Benefits

Easy Placing

The Unistrutt concrete insert is firmly fixed to the concrete side of shuttering before pouring.

Immediate use

When the shuttering is struck, the insert is ready to use.

Fixing at any point

Brackets and other components can be attached at any point along the Unistrutt continuous entry channel.

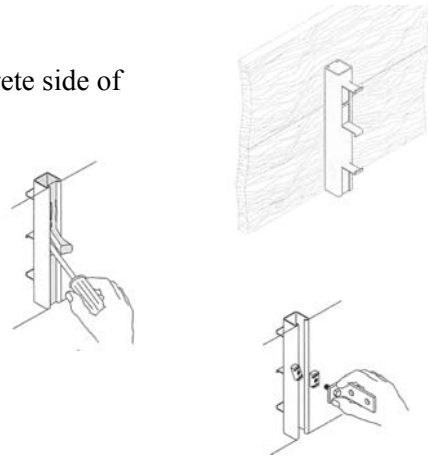

P3270

41mm x 41mm x 2.5mm thickness.
P3270 inserts are designed to accommodate 6mm, 8mm, 10mm, 12mm and 16mm O fixings. Normal cutting positions are between lugs as indicated.

Non standard lengths can be supplied in increments of 200mm (see also "short inserts").

Recommended loading on P3270 inserts in average strength concrete with a safety factory of approx. 3, is as follows. Inserts 300mm & over 900 Kgf pull out per 300mm.

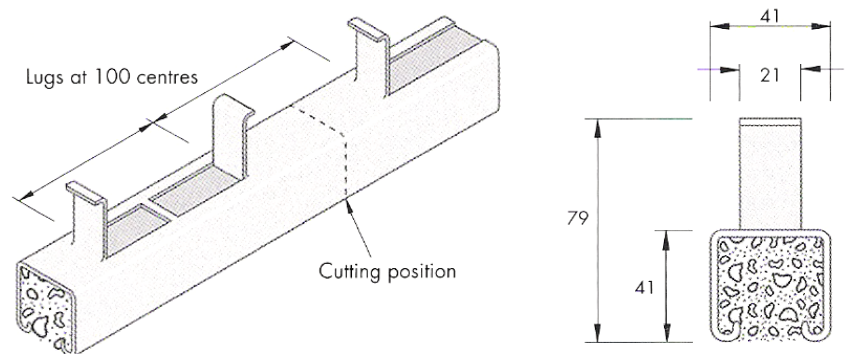

When ordering nuts to fit P3270 inserts, they are:-

16mm	Unistrutt stud Nut (63mm or 102mm long)
12mm	P3013/M12
10mm	P3008/M10
8mm	P3007/M8
6mm	P3006/M6

Finishes: PG, HG & SS. Standard Length: 6m, Wt. 17.82 kg per length.

P3370

41mm x 21mm x 2.5mm thickness.

P3370 inserts are designed to accommodate 6mm, 8mm, 10mm, 12mm and 16mm O fixings. Normal cutting positions are between lugs as indicated.

Nonstandard lengths can be supplied in increments of 200mm (see also "short inserts").

Recommended loading on P3370 inserts in average strength concrete with a safety factory of approx. 3, is as follows. Inserts 300mm & over 680 Kgf pull out per 300mm.

When ordering nuts to fit P3370 inserts, they are:-

16mm	Unistrut stud Nut (63mm or 102mm long)
12mm	P3013/M12
10mm	P3008/M10
8mm	P3007/M8
6mm	P3006/M6

Finishes: PG, HG & SS. Standard Length: 6m, Wt. 11.60 kg per length.

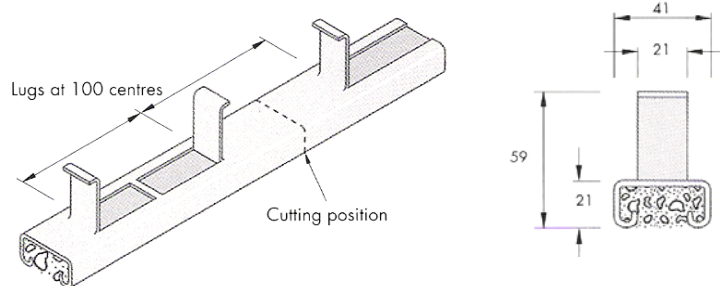

Concrete Inserts

Unistrut concrete inserts are manufactured from the standard Unistrut section and may be installed in floors, walls or ceilings, for the support of all types of piping, conduit, cable supports and other industrial equipment.

Unistrut nuts can be inserted anywhere along the length of the insert, providing means of attaching all kinds of fittings or rods where required. Unistrut inserts are available pre-filled with any easily removed foam, preventing the ingress of grout and cement. Concrete inserts can also be supplied in hot-dip-galvanized finish.

N.B. If a load is to be positioned within 50mm from the end of the concrete insert the approx. end cap P1704/1, P3704/1 or P4704/1 should be used to maintain recommended loading.

P3249 to P3251

Available in standard lengths, as listed, or cut and assembled on site.
Max. length 200mm.

For site assembly or P1000 foam filled channel and P1704/1 End Caps.

Recommended loading with safety factor of 3 – 900 Kgf pull out

Finishes : PG & HG

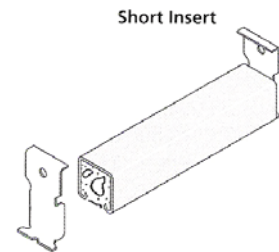

P3349 to P3351

Available in standard lengths, as listed, or cut and assembled on site. Max. length 200mm.

For site assembly or P1000 foam filled channel and P3704/1 End Caps.

Recommended loading with safety factor of 3 – 680 Kgf pull out

Finishes : PG & HG

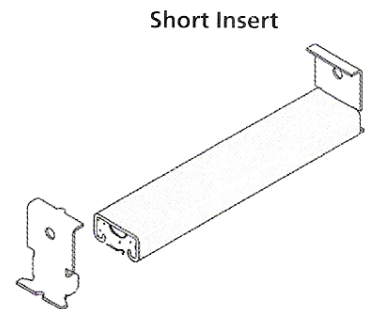

P1704/1

End Cap

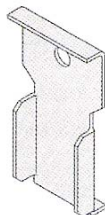

P3704/1

End Cap

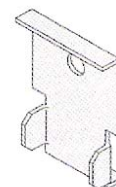

Universal Steel Connections

Type 'SK'

The 'SK' Load Table

Size mm	Installation Torque Nm	Tensile	SWL per clamp kg
M8	6		200
M10	7		275
M12	14		400

TUSC Type 'SK' beam clamp is manufactured in steel and utilizes a grade 8.8 clamping bolt. It is mainly used for suspending building services from primary or secondary steelwork.

Type 'SK' Dimensions Table

Size mm	Code	A mm	B mm	C mm	D mm	t(Effective) mm
8	8SK	25	46	15	45	19
10	10SK	25	46	17	45	19
12	12SK	25	46	20	45	19

Featured Include

Design allows it to be used on all rolled steel sections.

Manufactured from steel eliminating the risk of fracture from over tightening. Clear or tapped back fixing hole.
Zinc plated as standard.

Type 'BCS'

Type BCS Load Table

Size mm	Installation Torque Nm	Tensile	SWL per clamp kg
M8	10		100
M10	10		100

TUSC Type 'BCS' is a Beam Clamp with a self-aligning swivel for load attachment. The locking swivel allows a drop rod to hang vertically when the clamp is fixed to steel work inclined at any angle, in any plane, up to 30° from horizontal.

Size mm	t mm	A mm	B mm	C mm	D mm	E mm
M8	23	25	43	30	49	40
M10	23	25	43	30	49	40

Features Include:-

Design allows use on all rolled steel sections with flange thicknesses up to 23mm.

Type 'SK'

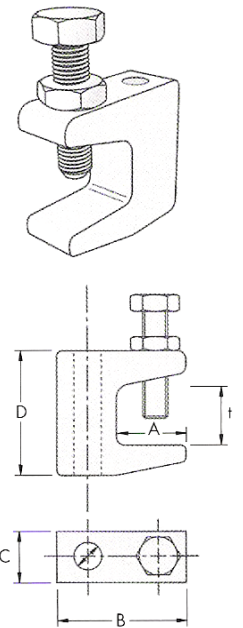

Type 'BCS'

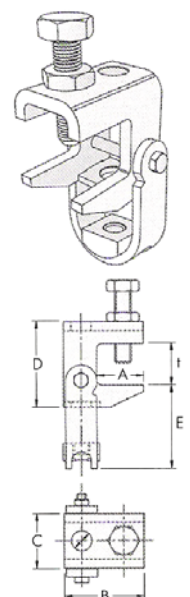



Manufactured from steel eliminating the risk of failure from over tightening. Self- Aligning at any angle up to 30°. The suspension rod is locked in position on final installation.

Simple & easy to install . Available to suit M8 or M10 suspension rods.

Zinc plated as standard.
Nickel Zinc plating available on request

Wedge Nut

Part No.	Size	Weight KG/ 100
WN/M6	M6	2.30
WN/M8	M8	2.25
WN/M10	M10	2.20
WN/M6small	M6	1.60

Finishes : ZP

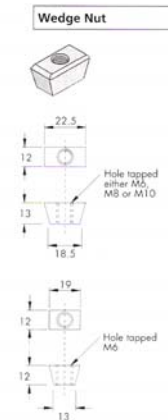

Type 'WPC'

TUSE Type 'WPC' Wrap Around Purlin Hangers can be used to fit all commonly used proprietary purlin section, allows drop rod to hang vertically from purlin.

Rocking plate accepts M6 – M10 threaded rod. Specify rod size when ordering. Max. load 75Kg subject to strength of purlin.

Finishes : ZP

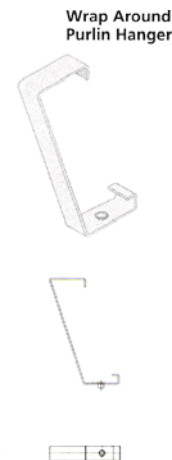

Type 'PC'

TUSE Type 'PC' Purlin Clip is designed to fix on to all commonly used proprietary purline sections.

Clearance holes punched to pass M10 bolt or drop rod.

Top and bottom faces should be parallel on completion of installation.

Max load 25 Kg.

Finishes : ZP

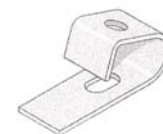

Beam Clamps, Pipe Clamps & Pipe Hangers

AB-880 / AB-881

Prod #	A mm		Max Cable Diam.		Wt/C lbs. (Kg.)	
AB-880	3	(76)	3	(76)	73	(33)
AB-881	4	(101.6)	4-1/2	(114)	104	(47)

AB-880

3" (76) Procelain
Saddle

AB-881

4" (101.6) Procelain
Saddle

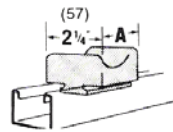

U-560

Dimensions (inches/ mm) – Weights - Loads

Prod #	A mm		B mm		C		Wt/C lbs. (Kg.)		Design Load lbs. (KN.)	
U-560-1/4	(6) 1/4	(6) 1/8	(3) 3/8	(10) X	1-1/2	(39) 67	(30.4)	650	(2.9)	
U-560-3/8	(10) 3/8	(10) 1/8	(3) 3/8	(10) X	1-1/2	(39) 67	(30.4)	650	(2.9)	
U-560-1/2	(13) 1/2	(13) 1/4	(6) 1/2	(13) X	1-1/2	(39) 130	(59)	1600	(7.1)	
U-560-5/8	(16) 5/8	(16) 1/4	(6) 1/2	(13) X	1-1/2	(39) 130	(59)	1600	(7.1)	

U-560

Heavy Duty
Beam Clamp

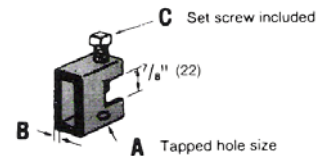

U-564

Prod #	A mm		B mm		C		Wt/C lbs. (Kg.)		Design Load Lbs. (KN.)	
U-564-1	1/4	(6)	1/8	(3)	3/8 X	2-3/4	(9.5 X 70)	109	(49.4)	800 (3.5)
U-564-2	5/16	(8.0)	1/8	(3)	3/8 X	2-3/4	(9.5 X 70)	109	(49.4)	800 (3.5)
U-564-3	3/8	(9.5)	1/8	(3)	3/8 X	2-3/4	(9.5 X 70)	109	(49.4)	800 (3.5)
U-564-4	3/8	(9.5)	3/16	(5)	1/2 X	2-3/4	(13 X 70)	156	(71)	1300 (5.8)
U-564-5	1/2	(13)	3/16	(5)	1/2 X	2-3/4	(13 X 70)	156	(71)	1300 (5.8)
U-564-6	1/2	(13)	1/4	(6)	1/2 X	2-3/4	(13 X 70)	201	(91)	1900 (8.4)
U-564-7	5/8	(16)	1/4	(6)	1/2 X	2-3/4	(13 X 70)	201	(91)	1900 (8.4)
U-564-8	5/8	(16)	5/16	(8.0)	5/8 X	2-3/4	(16 X 70)	251	(114)	2800(12.4)
U-564-9	3/4	(19)	5/16	(8.0)	5/8 X	2-3/4	(16 X 70)	251	(114)	2800(12.4)

U-564

Heavy Duty
Beam Clamp

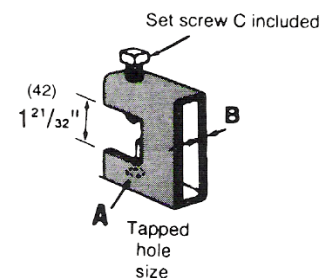

RC

Saudisstrut Cat No. & Sizes	Dimensions in inches		Wt. In Lbs./C (Kg.)
	O.D. of Conduit or Pipe	Nom. Conduit or Pipe Size	
RC - ½ (13)	0.840 (21)	½ (13)	36 (16)
RC - ¾ (19)	1.050 (27)	¾ (19)	41 (18)
RC - 1 (25.4)	1.315 (33.4)	1 (25.4)	42 (19)
RC - 1 ¼ (32)	1.660 (42)	1 ¼ (32)	50 (23)
RC - 1 ½ (38)	1.900 (48)	1 ½ (38)	57 (26)
RC - 2 - SC (51)	2.375 (60)	2 (51)	78 (35)
RC - 2 ½ (63.5)	2.875 (73)	2 ½ (63.5)	109 (49)
RC - 3 (76)	3.500 (89)	3 (76)	118 (53)
RC 3 ½ (89)	4.000 (101.6)	3 ½ (88.4)	134 (61)
RC - 4 - SC (101.6)	4.500 (114)	4 (101.6)	144 (65)



For mounting pipes
or conduit at
right angles
to the beam.

(Ordered from U.S)

PC

Saudisstrut Cat No. & Sizes	Dimensions in inches		Wt. In Lbs./C (Kg.)
	O.D. of Conduit or Pipe	Nom. Conduit or Pipe Size	
RC - ½ (13)	0.840 (21)	½ (13)	51 (23)
RC - ¾ (19)	1.050 (27)	¾ (19)	54 (24)
RC - 1 (25.4)	1.315 (33.4)	1 (25.4)	63 (28)
RC - 1 ¼ (32)	1.660 (42)	1 ¼ (32)	80 (36)
RC - 1 ½ (38)	1.900 (48)	1 ½ (38)	90 (41)
RC - 2 - SC (51)	2.375 (60)	2 (51)	115 (52)
RC - 2 ½ (63.5)	2.875 (73)	2 ½ (63.5)	148 (67)
RC - 3 (76)	3.500 (89)	3 (76)	178 (81)
RC 3 ½ (89)	4.000 (101.6)	3 ½ (88.4)	209 (95)
RC - 4 - SC (101.6)	4.500 (114)	4 (101.6)	224 (101)



For mounting p:
or conduit para
to the beam

(Ordered from U.S)

EC

Saudisstrut Cat No. & Sizes	Dimensions in inches		Wt. In Lbs./C (Kg.)
	O.D. of Conduit or Pipe	Nom. Conduit or Pipe Size	
RC - ½ (13)	0.840 (21)	½ (13)	68 (31)
RC - ¾ (19)	1.050 (27)	¾ (19)	75 (34)
RC - 1 (25.4)	1.315 (33.4)	1 (25.4)	85 (38)
RC - 1 ¼ (32)	1.660 (42)	1 ¼ (32)	98 (44)
RC - 1 ½ (38)	1.900 (48)	1 ½ (38)	105 (41)
RC - 2 - SC (51)	2.375 (60)	2 (51)	141 (64)
RC - 2 ½ (63.5)	2.875 (73)	2 ½ (63.5)	188 (85)
RC - 3 (76)	3.500 (89)	3 (76)	232 (105)



For mounting pipe
or conduit vertical
cross beam edge.

(Ordered from U.S)