

Saudi Superstrut

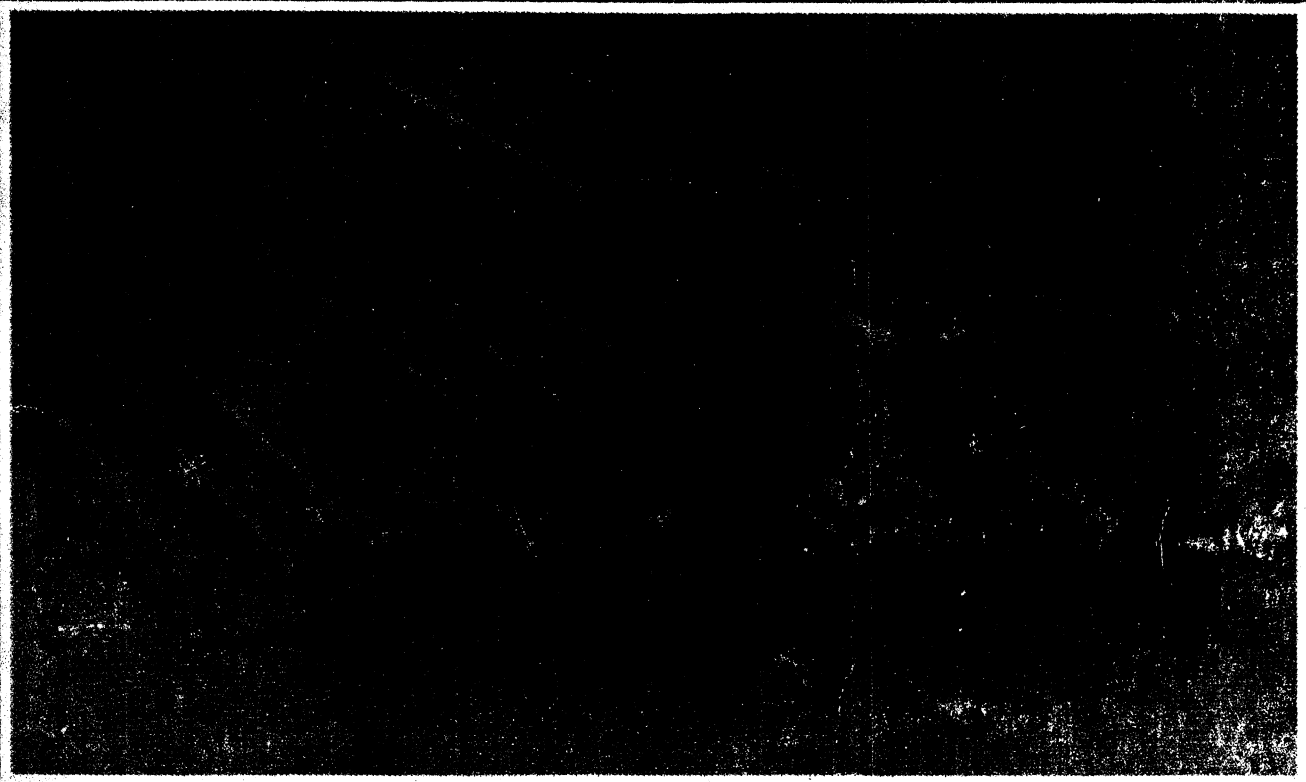

Architectural
Industrial

Electrical
Mechanical

Plumbing
Refrigeration

Manufactured in Saudi Arabia by
ABAHSAIN-COPE S.A. LTD. CR#7066

Table of Contents

	How to Order	2
Section	1—Metal Framing Channels (Series 1000)	3
	• Standard Channel	4
	• Welded Combination	5
Section	2—Threaded Products and Hardware (Series 100)	6
	• Nuts and Bolts	7
Section	3—Fittings and Brackets (Series 200)	10
	• 90° Angle Fittings	11
	• Flat Plate Fittings	12
	• Angular Fittings	14
	• "Z" Shape Fittings	14
	• Wing Shape Fittings	14
	• "U" Shape Fittings	16
	• Post Bases	17
	• Special Application Fittings	17
	• Brackets	18
Section	4—Concrete Inserts (Series 300,400)	20
Section	5—Beam Clamps, Pipe Clamps and Pipe Hangers (Series 500 , 700 , 800)	23
	• Pipe Straps	24
	• Pipe Clamps	28
	• Cable Clamps	29
	• Beam Clamps for Mounting Channel	30
	• Beam Clamps for Hanging Rod	32
	• Beam Clamps for Mounting Pipe and Conduit	37
	• Pipe Hangers	38
	• Saddles and Rollers	41
Section	6—Surface Raceway and Lighting Support Systems (Series 800)	43
	• Electrical Application	44
	• Fixture Fittings	47
Section	7—Standard Packing and Bundling	50
Section	8—Special Metals	51
Section	9—Engineering Data and Specification	52
	• Design Data—Metal framing Channels	52
	• Design Applications	59
Section	10—Alphanumeric Index	66
Section	11—Cable Ladder System	70
Section	12—Abco-Mavil Cable trays with Return Flanges	71
Section	13—Supports For Cable trays	72

How To Order

1. Select proper catalog number:

The engineering catalog is organized by groups of like products used for like applications. Price lists are organized numerically by catalog number for ease in pricing when catalog numbers are known.

Catalog numbers consist of a product identification number, followed by size or length, whichever is applicable.

2. Finishes available:

(a) **Black** (suffix B)-Steel is grayblack in color, and oiled just as it comes from the mill. Sometimes this finish is referred to as "black".

(b) **Hot-dipped galvanized** (suffix HDG)-material is zinc coated by the hot-dipped method after fabrication. This often causes assembly problems for threaded products. Coating is in conformance with ASTM specifications A-123, A-153 and A-386.

(c) **Electro-galvanized** (suffix EG)-plated zinc without the gold colored dichromate conversion coat. Superstrut recommends this finish for threaded products on a hot-dipped galvanized job.

Plating is in conformance with ASTM specification B633-85.

(d) **Pre-galvanized** (suffix PG)-steel is hot-dipped galvanized at the mill prior to cutting, punching, or forming. No protection is provided for raw edges after fabrication.

Coating is in conformance with ASTM specification A-525 (G 90).

(e) Several other types of plating, or coatings are possible—consult the factory for details.

WARNING: Load tables, charts, and design criteria provided in this catalog are intended as guided only. Selection of proper product, installation intervals, erection, and placement are the responsibility of the user.

Pipe hanger products when improperly used as tools of erection have occasionally failed. The user is cautioned to use the product only as it was intended, to avoid an accident.

We reserve the right to change material and finish specifications without notice, to improve our products.

METAL FRAMING CHANNELS

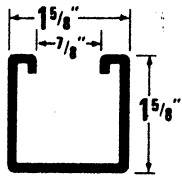

A SERIES

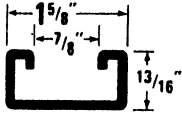

B SERIES

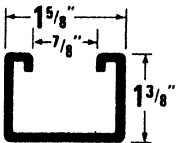

C SERIES

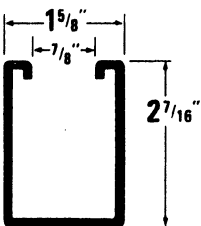

E SERIES

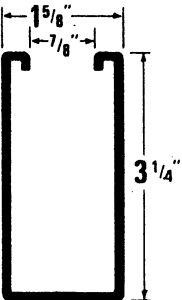

H SERIES

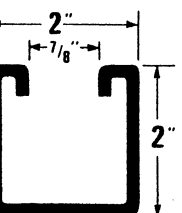

K SERIES

MATERIAL

Channels are cold formed from pickled and oiled mild strip steel. Multiple channels are spot welded on 3" centers.

MATERIAL THICKNESS

All series 1000.....	10 gauge material
All series 1200.....	12 gauge material
All series 1400.....	14 gauge material
All series 1600.....	16 gauge material

NOTE: Exact thickness may vary slightly due to commercial tolerances.

STANDARD LENGTHS

Standard lengths for channel are 10 ft. and 20 ft.
Standard length tolerance plus or minus 1/8".
Shorter lengths are available at a small cutting charge.

STANDARD FINISH

Saudi Superstrut channel is manufactured from pre-galvanized steel. The steel is hot-dipped galvanized at the mill prior to cutting, punching, or forming. The coating is in conformance with ASTM specification A-525 (G90).

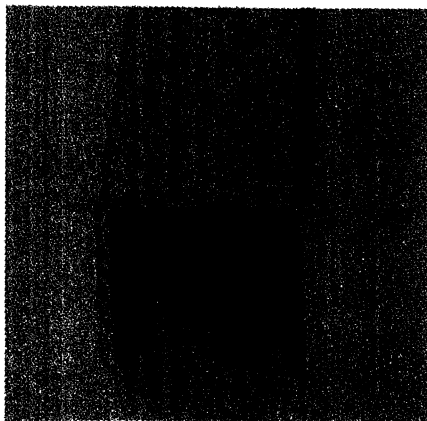
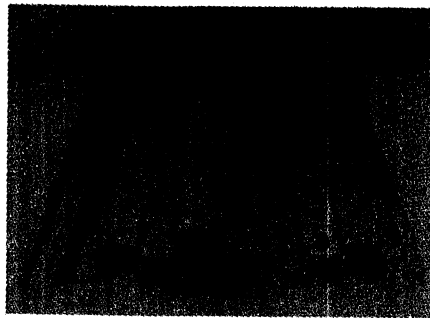

SECTION 1

Metal Framing Channels — Series 1000

Standard Channels

<p>A-1200</p> <p>Channel available in Solid, Half Slot, Punched, Slotted and Knockout configurations.</p> <p>wt./ft. 1.90 lbs.</p>	<p>B-1200</p> <p>Channel available in Solid, Half Slot, Punched and Slotted configurations.</p> <p>wt./ft. 1.28 lbs.</p>	<p>C-1200</p> <p>Channel available in Solid, Half Slot and Punched configurations.</p> <p>wt./ft. 1.70 lbs.</p>
<p>E-1200</p> <p>Channel available in Solid, Half Slot and Punched configurations.</p> <p>wt./ft. 2.47 lbs.</p>	<p>H-1200</p> <p>Channel available in Solid, Half Slot and Punched configurations.</p> <p>wt./ft. 3.05 lbs.</p>	<p>A-1400</p> <p>Channel available in Solid, Half Slot, Punched, Slotted and Knockout configurations.</p> <p>wt./ft. 1.40 lbs.</p>
<p>B-1400</p> <p>Channel available in Solid, Half Slot, Punched and Slotted configurations.</p> <p>wt./ft. 0.97 lbs.</p>		

<p>Half Slot Channel</p> <p>9/16" x 1-1/8" slots on 2" centers</p> <table border="1"> <thead> <tr> <th>Prod. #</th> <th>Dim.</th> <th>Ga.</th> <th>Wt./ft. lbs.</th> </tr> </thead> <tbody> <tr><td>A-1200-HS</td><td>1-5/8 x 1-5/8</td><td>12</td><td>1.85</td></tr> <tr><td>B-1200-HS</td><td>1-5/8 x 13/16</td><td>12</td><td>1.23</td></tr> <tr><td>C-1200-HS</td><td>1-5/8 x 1-3/8</td><td>12</td><td>1.65</td></tr> <tr><td>E-1200-HS</td><td>1-5/8 x 2-7/16</td><td>12</td><td>2.42</td></tr> <tr><td>H-1200-HS</td><td>1-5/8 x 3-1/4</td><td>12</td><td>3.00</td></tr> <tr><td>A-1400-HS</td><td>1-5/8 x 1-5/8</td><td>14</td><td>1.36</td></tr> <tr><td>B-1400-HS</td><td>1-5/8 x 13/16</td><td>14</td><td>0.87</td></tr> </tbody> </table>	Prod. #	Dim.	Ga.	Wt./ft. lbs.	A-1200-HS	1-5/8 x 1-5/8	12	1.85	B-1200-HS	1-5/8 x 13/16	12	1.23	C-1200-HS	1-5/8 x 1-3/8	12	1.65	E-1200-HS	1-5/8 x 2-7/16	12	2.42	H-1200-HS	1-5/8 x 3-1/4	12	3.00	A-1400-HS	1-5/8 x 1-5/8	14	1.36	B-1400-HS	1-5/8 x 13/16	14	0.87	<p>Slotted Channel</p> <p>7/16" x 3" slots on 4" centers</p> <table border="1"> <thead> <tr> <th>Prod. #</th> <th>Dim.</th> <th>Ga.</th> <th>Wt./ft. lbs.</th> </tr> </thead> <tbody> <tr><td>A-1200-S</td><td>1-5/8 x 1-5/8</td><td>12</td><td>1.80</td></tr> <tr><td>B-1200-S</td><td>1-5/8 x 13/16</td><td>12</td><td>1.18</td></tr> <tr><td>A-1400-S</td><td>1-5/8 x 1-5/8</td><td>14</td><td>1.37</td></tr> <tr><td>B-1400-S</td><td>1-5/8 x 13/16</td><td>14</td><td>.85</td></tr> </tbody> </table>	Prod. #	Dim.	Ga.	Wt./ft. lbs.	A-1200-S	1-5/8 x 1-5/8	12	1.80	B-1200-S	1-5/8 x 13/16	12	1.18	A-1400-S	1-5/8 x 1-5/8	14	1.37	B-1400-S	1-5/8 x 13/16	14	.85	<p>Punched Channel</p> <p>9/16" holes on 1-7/8" centers</p> <table border="1"> <thead> <tr> <th>Prod. #</th> <th>Dim.</th> <th>Ga.</th> <th>Wt./ft. lbs.</th> </tr> </thead> <tbody> <tr><td>A-1200-P</td><td>1-5/8 x 1-5/8</td><td>12</td><td>1.85</td></tr> <tr><td>B-1200-P</td><td>1-5/8 x 13/16</td><td>12</td><td>1.23</td></tr> <tr><td>C-1200-P</td><td>1-5/8 x 1-3/8</td><td>12</td><td>1.65</td></tr> <tr><td>E-1200-P</td><td>1-5/8 x 2-7/16</td><td>12</td><td>2.42</td></tr> <tr><td>H-1200-P</td><td>1-5/8 x 3-1/4</td><td>12</td><td>3.00</td></tr> <tr><td>A-1400-P</td><td>1-5/8 x 1-5/8</td><td>14</td><td>1.36</td></tr> <tr><td>B-1400-P</td><td>1-5/8 x 13/16</td><td>14</td><td>0.87</td></tr> </tbody> </table>	Prod. #	Dim.	Ga.	Wt./ft. lbs.	A-1200-P	1-5/8 x 1-5/8	12	1.85	B-1200-P	1-5/8 x 13/16	12	1.23	C-1200-P	1-5/8 x 1-3/8	12	1.65	E-1200-P	1-5/8 x 2-7/16	12	2.42	H-1200-P	1-5/8 x 3-1/4	12	3.00	A-1400-P	1-5/8 x 1-5/8	14	1.36	B-1400-P	1-5/8 x 13/16	14	0.87
Prod. #	Dim.	Ga.	Wt./ft. lbs.																																																																																			
A-1200-HS	1-5/8 x 1-5/8	12	1.85																																																																																			
B-1200-HS	1-5/8 x 13/16	12	1.23																																																																																			
C-1200-HS	1-5/8 x 1-3/8	12	1.65																																																																																			
E-1200-HS	1-5/8 x 2-7/16	12	2.42																																																																																			
H-1200-HS	1-5/8 x 3-1/4	12	3.00																																																																																			
A-1400-HS	1-5/8 x 1-5/8	14	1.36																																																																																			
B-1400-HS	1-5/8 x 13/16	14	0.87																																																																																			
Prod. #	Dim.	Ga.	Wt./ft. lbs.																																																																																			
A-1200-S	1-5/8 x 1-5/8	12	1.80																																																																																			
B-1200-S	1-5/8 x 13/16	12	1.18																																																																																			
A-1400-S	1-5/8 x 1-5/8	14	1.37																																																																																			
B-1400-S	1-5/8 x 13/16	14	.85																																																																																			
Prod. #	Dim.	Ga.	Wt./ft. lbs.																																																																																			
A-1200-P	1-5/8 x 1-5/8	12	1.85																																																																																			
B-1200-P	1-5/8 x 13/16	12	1.23																																																																																			
C-1200-P	1-5/8 x 1-3/8	12	1.65																																																																																			
E-1200-P	1-5/8 x 2-7/16	12	2.42																																																																																			
H-1200-P	1-5/8 x 3-1/4	12	3.00																																																																																			
A-1400-P	1-5/8 x 1-5/8	14	1.36																																																																																			
B-1400-P	1-5/8 x 13/16	14	0.87																																																																																			
<p>Channel with Knockouts</p> <p>KO for 1/2" conduit</p> <table border="1"> <thead> <tr> <th>Prod. #</th> <th>Dim.</th> <th>Ga.</th> <th>Wt./ft. lbs.</th> </tr> </thead> <tbody> <tr><td>A-1200 KO</td><td>1-5/8 x 1-5/8</td><td>12</td><td>1.90</td></tr> <tr><td>A-1400 KO</td><td>1-5/8 x 1-5/8</td><td>14</td><td>1.40</td></tr> </tbody> </table>			Prod. #	Dim.	Ga.	Wt./ft. lbs.	A-1200 KO	1-5/8 x 1-5/8	12	1.90	A-1400 KO	1-5/8 x 1-5/8	14	1.40																																																																								
Prod. #	Dim.	Ga.	Wt./ft. lbs.																																																																																			
A-1200 KO	1-5/8 x 1-5/8	12	1.90																																																																																			
A-1400 KO	1-5/8 x 1-5/8	14	1.40																																																																																			

Superstrut Channels - Welded Combinations

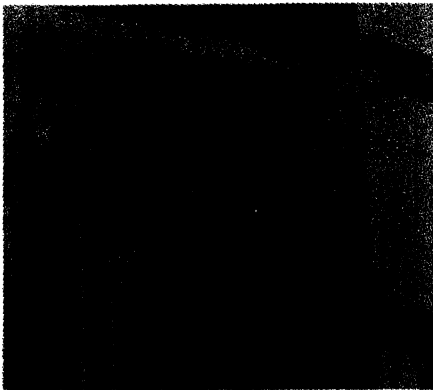

All Superstrut Channels are available in a variety of combinations - some are shown below.

How To Order

10 and 20 ft. lengths - steel.
Special Lengths may be ordered.
Replace the last digit of the regular channel catalog number with the designation of the desired combination.

EXAMPLES: Two A-1200 channels back to back are ordered as A-1202.
Two A-1200 channels back to side are ordered as A-1202-C.

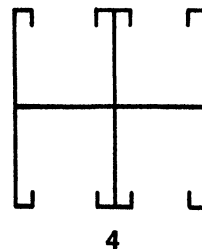
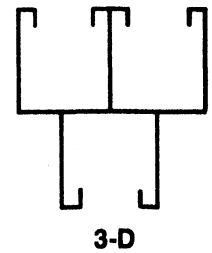
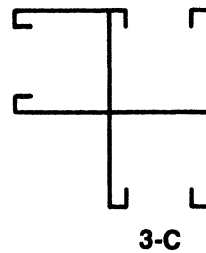
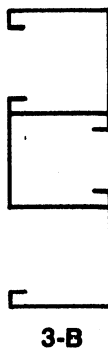
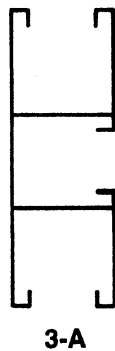
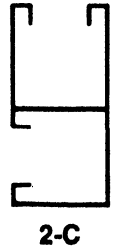
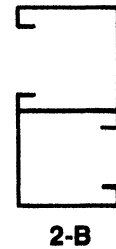
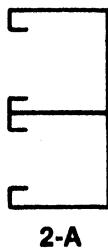
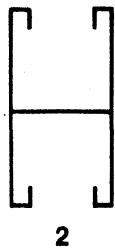

SECTION 2 Threaded Products and Hardware — Series 100

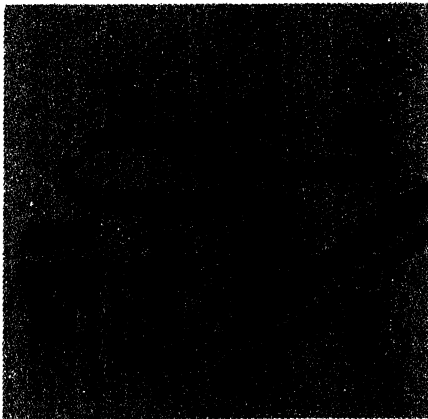

Material

Superstrut channel nuts are manufactured from mild steel and are case hardened.

Screw Threads

All threaded products are American Standard thread, free fit class 2.

Thread Size	1/4	5/16	3/8	1/2
Threads per Inch	20	18	16	13
Design Torque (ft.-lbs.)	6	11	19	50

Design Data

Superstrut self aligning channel nuts are designed to provide resistance to pull out and resistance to side slip in excess of the full strength of the channels with which they are used.

The extreme resistance to side slip results from the unique design of the alternate teeth, spaced and designed to develop a wedging action that increases with pressure or load.

Nylon Cone Nut

Eliminates the inventory and installation hassles of conventional spring nuts. Fits all 1 5/8" channel, regardless of depth, with a simple twist of your thumb. Pliable nylon cone secures the nut in place through the entire range of construction site temperatures.







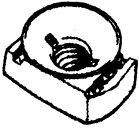
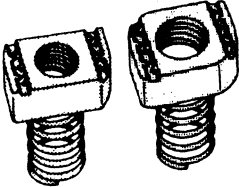
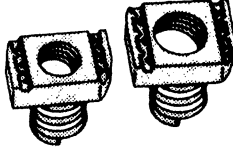
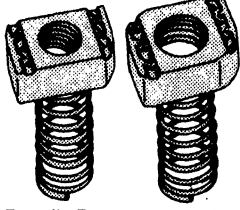
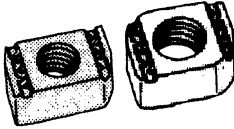
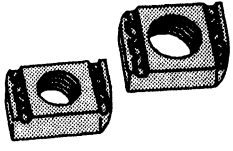
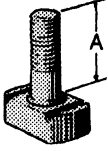

PAGE

7

•Nuts and Bolts

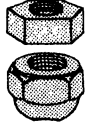
Threaded Products and Hardware — Series 100 SECTION 2

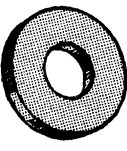
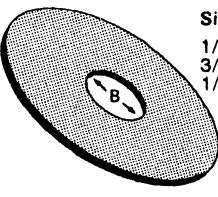
Nuts and Bolts

<p>CM-100 Nylon Cone Nut</p>  <table border="1"> <thead> <tr> <th>Prod. # & size</th> <th>Wt./C lbs.</th> </tr> </thead> <tbody> <tr> <td>CM-100-1/4</td> <td>8</td> </tr> <tr> <td>CM-100-3/8</td> <td>10</td> </tr> <tr> <td>CM-100-1/2</td> <td>12</td> </tr> <tr> <td>CM-100B-1/2</td> <td>10</td> </tr> </tbody> </table> <p>For all 1-5/8" channel, regardless of depth</p> <p>*Will not fit B series channel</p>	Prod. # & size	Wt./C lbs.	CM-100-1/4	8	CM-100-3/8	10	CM-100-1/2	12	CM-100B-1/2	10	<p>A-100 Regular Spring Nut</p>  <table border="1"> <thead> <tr> <th>Prod. # & size</th> <th>Wt./C lbs.</th> </tr> </thead> <tbody> <tr> <td>A-100-1 4</td> <td>8</td> </tr> <tr> <td>A-100-5 16</td> <td>9</td> </tr> <tr> <td>A-100-3 8</td> <td>10</td> </tr> <tr> <td>A-100-1 2</td> <td>12</td> </tr> </tbody> </table> <p>Nut is square over 1-2" size</p> <table border="1"> <tbody> <tr> <td>A-100-5 8</td> <td>19</td> </tr> <tr> <td>A-100-3 4</td> <td>19</td> </tr> <tr> <td>A-100-7 8</td> <td>18</td> </tr> </tbody> </table> <p>For all A and C series channels and inserts</p>	Prod. # & size	Wt./C lbs.	A-100-1 4	8	A-100-5 16	9	A-100-3 8	10	A-100-1 2	12	A-100-5 8	19	A-100-3 4	19	A-100-7 8	18	<p>B-100 Short Spring Nut</p>  <table border="1"> <thead> <tr> <th>Prod. # & size</th> <th>Wt./C lbs.</th> </tr> </thead> <tbody> <tr> <td>B-100-1/4</td> <td>7</td> </tr> <tr> <td>B-100-5/16</td> <td>8</td> </tr> <tr> <td>B-100-3/8</td> <td>9</td> </tr> <tr> <td>B-100-1/2</td> <td>9</td> </tr> </tbody> </table> <p>Nut is square over 1/2" size</p> <p>For all B series channels and inserts</p>	Prod. # & size	Wt./C lbs.	B-100-1/4	7	B-100-5/16	8	B-100-3/8	9	B-100-1/2	9												
Prod. # & size	Wt./C lbs.																																																	
CM-100-1/4	8																																																	
CM-100-3/8	10																																																	
CM-100-1/2	12																																																	
CM-100B-1/2	10																																																	
Prod. # & size	Wt./C lbs.																																																	
A-100-1 4	8																																																	
A-100-5 16	9																																																	
A-100-3 8	10																																																	
A-100-1 2	12																																																	
A-100-5 8	19																																																	
A-100-3 4	19																																																	
A-100-7 8	18																																																	
Prod. # & size	Wt./C lbs.																																																	
B-100-1/4	7																																																	
B-100-5/16	8																																																	
B-100-3/8	9																																																	
B-100-1/2	9																																																	
<p>H-100 Long Spring Nut</p>  <table border="1"> <thead> <tr> <th>Prod. # & size</th> <th>Wt./C lbs.</th> </tr> </thead> <tbody> <tr> <td>H-100-3/8</td> <td>10</td> </tr> <tr> <td>H-100-1/2</td> <td>14</td> </tr> </tbody> </table> <p>Nut is square over 1/2" size</p> <table border="1"> <tbody> <tr> <td>H-100-5/8</td> <td>20</td> </tr> </tbody> </table> <p>For all "E" and "H" series channels and inserts</p>	Prod. # & size	Wt./C lbs.	H-100-3/8	10	H-100-1/2	14	H-100-5/8	20	<p>AC-100 Springless Nut</p>  <table border="1"> <thead> <tr> <th>Prod. # & size</th> <th>Wt./C lbs.</th> </tr> </thead> <tbody> <tr> <td>AC-100-1/4</td> <td>7</td> </tr> <tr> <td>AC-100-3/8</td> <td>9</td> </tr> <tr> <td>AC-100-1/2</td> <td>11</td> </tr> </tbody> </table> <p>Nut is square over 1/2" size</p> <table border="1"> <tbody> <tr> <td>AC-100-5/8</td> <td>18</td> </tr> <tr> <td>AC-100-3/4</td> <td>18</td> </tr> </tbody> </table> <p>For all "A", "C", "E" and "H" series channels and inserts.</p>	Prod. # & size	Wt./C lbs.	AC-100-1/4	7	AC-100-3/8	9	AC-100-1/2	11	AC-100-5/8	18	AC-100-3/4	18	<p>AB-100 Springless Nut</p>  <table border="1"> <thead> <tr> <th>Prod. # & size</th> <th>Wt./C lbs.</th> </tr> </thead> <tbody> <tr> <td>AB-100-1/4</td> <td>7</td> </tr> <tr> <td>AB-100-5/16</td> <td>8</td> </tr> <tr> <td>AB-100-3/8</td> <td>9</td> </tr> <tr> <td>AB-100-1/2</td> <td>9</td> </tr> </tbody> </table> <p>Nut is square over 1/2" size.</p> <table border="1"> <tbody> <tr> <td>AB-100-5/8</td> <td>10</td> </tr> <tr> <td>AB-100-3/4</td> <td>10</td> </tr> </tbody> </table> <p>For use with all channels.</p>	Prod. # & size	Wt./C lbs.	AB-100-1/4	7	AB-100-5/16	8	AB-100-3/8	9	AB-100-1/2	9	AB-100-5/8	10	AB-100-3/4	10														
Prod. # & size	Wt./C lbs.																																																	
H-100-3/8	10																																																	
H-100-1/2	14																																																	
H-100-5/8	20																																																	
Prod. # & size	Wt./C lbs.																																																	
AC-100-1/4	7																																																	
AC-100-3/8	9																																																	
AC-100-1/2	11																																																	
AC-100-5/8	18																																																	
AC-100-3/4	18																																																	
Prod. # & size	Wt./C lbs.																																																	
AB-100-1/4	7																																																	
AB-100-5/16	8																																																	
AB-100-3/8	9																																																	
AB-100-1/2	9																																																	
AB-100-5/8	10																																																	
AB-100-3/4	10																																																	
<p>A-177 to A-180 Springless Stud Nut</p>  <table border="1"> <thead> <tr> <th>Prod. # & size</th> <th>Bolt Dia.</th> <th>Length A</th> </tr> </thead> <tbody> <tr> <td>A-177-1/4 x 1</td> <td>1/4</td> <td>1</td> </tr> <tr> <td>A-177-1/4 x 1-1/4</td> <td>1/4</td> <td>1 1/4</td> </tr> <tr> <td>A-179-3/8 x 1</td> <td>3/8</td> <td>1</td> </tr> <tr> <td>A-179-3/8 x 1-1/4</td> <td>3/8</td> <td>1 1/4</td> </tr> <tr> <td>A-180-1/2 x 1</td> <td>1/2</td> <td>1</td> </tr> <tr> <td>A-180-1/2 x 1-1/4</td> <td>1/2</td> <td>1 1/4</td> </tr> </tbody> </table> <p>For use with all channels*</p> <p>*Cannot be used with "B" series channel.</p>	Prod. # & size	Bolt Dia.	Length A	A-177-1/4 x 1	1/4	1	A-177-1/4 x 1-1/4	1/4	1 1/4	A-179-3/8 x 1	3/8	1	A-179-3/8 x 1-1/4	3/8	1 1/4	A-180-1/2 x 1	1/2	1	A-180-1/2 x 1-1/4	1/2	1 1/4	<p>A-182 to A-185 Regular Spring Stud Nut</p>  <table border="1"> <thead> <tr> <th>Prod. # & size</th> <th>Bolt Dia.</th> <th>Length A</th> </tr> </thead> <tbody> <tr> <td>A-182-1/4 x 1</td> <td>1/4</td> <td>1</td> </tr> <tr> <td>A-182-1/4 x 1-1/4</td> <td>1/4</td> <td>1 1/4</td> </tr> <tr> <td>A-184-3/8 x 1</td> <td>3/8</td> <td>1</td> </tr> <tr> <td>A-184-3/8 x 1-1/4</td> <td>3/8</td> <td>1 1/4</td> </tr> <tr> <td>A-185-1/2 x 1</td> <td>1/2</td> <td>1</td> </tr> <tr> <td>A-185-1/2 x 1-1/4</td> <td>1/2</td> <td>1 1/4</td> </tr> </tbody> </table> <p>For all "A" and "C" series channels.</p>	Prod. # & size	Bolt Dia.	Length A	A-182-1/4 x 1	1/4	1	A-182-1/4 x 1-1/4	1/4	1 1/4	A-184-3/8 x 1	3/8	1	A-184-3/8 x 1-1/4	3/8	1 1/4	A-185-1/2 x 1	1/2	1	A-185-1/2 x 1-1/4	1/2	1 1/4	<p>ES-142</p>  <table border="1"> <thead> <tr> <th>Prod. # & size</th> <th>Bolt Dia.</th> <th>Wt./C lbs.</th> </tr> </thead> <tbody> <tr> <td>ES-142-1/2 x 1-1/2</td> <td>1/2</td> <td>21</td> </tr> </tbody> </table> <p>Seismic bracing rod stiffener connector.</p>	Prod. # & size	Bolt Dia.	Wt./C lbs.	ES-142-1/2 x 1-1/2	1/2	21
Prod. # & size	Bolt Dia.	Length A																																																
A-177-1/4 x 1	1/4	1																																																
A-177-1/4 x 1-1/4	1/4	1 1/4																																																
A-179-3/8 x 1	3/8	1																																																
A-179-3/8 x 1-1/4	3/8	1 1/4																																																
A-180-1/2 x 1	1/2	1																																																
A-180-1/2 x 1-1/4	1/2	1 1/4																																																
Prod. # & size	Bolt Dia.	Length A																																																
A-182-1/4 x 1	1/4	1																																																
A-182-1/4 x 1-1/4	1/4	1 1/4																																																
A-184-3/8 x 1	3/8	1																																																
A-184-3/8 x 1-1/4	3/8	1 1/4																																																
A-185-1/2 x 1	1/2	1																																																
A-185-1/2 x 1-1/4	1/2	1 1/4																																																
Prod. # & size	Bolt Dia.	Wt./C lbs.																																																
ES-142-1/2 x 1-1/2	1/2	21																																																
<p>E-145 Standard Hex Nut</p>  <table border="1"> <thead> <tr> <th>Size</th> <th>Wt./C lbs.</th> </tr> </thead> <tbody> <tr> <td>1/4</td> <td>.72</td> </tr> <tr> <td>3/8</td> <td>1.06</td> </tr> <tr> <td>1/2</td> <td>2.78</td> </tr> <tr> <td>5/8</td> <td>6.92</td> </tr> <tr> <td>3/4</td> <td>12.70</td> </tr> <tr> <td>7/8</td> <td>19.00</td> </tr> <tr> <td>1</td> <td>28.00</td> </tr> </tbody> </table>	Size	Wt./C lbs.	1/4	.72	3/8	1.06	1/2	2.78	5/8	6.92	3/4	12.70	7/8	19.00	1	28.00	<p>ES-145 Swivel Nut and Jam Nut Combination</p>  <table border="1"> <thead> <tr> <th>Prod. # & Size</th> <th>Wt./C lbs.</th> </tr> </thead> <tbody> <tr> <td>ES-145-3/8</td> <td>5.5</td> </tr> <tr> <td>ES-145-1/2</td> <td>6.0</td> </tr> </tbody> </table>	Prod. # & Size	Wt./C lbs.	ES-145-3/8	5.5	ES-145-1/2	6.0	<p>E-146 Standard Square Nut</p>  <table border="1"> <thead> <tr> <th>Size</th> <th>Wt./C lbs.</th> </tr> </thead> <tbody> <tr> <td>1/4</td> <td>.93</td> </tr> <tr> <td>5/16</td> <td>1.60</td> </tr> <tr> <td>3/8</td> <td>2.65</td> </tr> <tr> <td>1/2</td> <td>5.83</td> </tr> <tr> <td>5/8</td> <td>10.80</td> </tr> </tbody> </table>	Size	Wt./C lbs.	1/4	.93	5/16	1.60	3/8	2.65	1/2	5.83	5/8	10.80														
Size	Wt./C lbs.																																																	
1/4	.72																																																	
3/8	1.06																																																	
1/2	2.78																																																	
5/8	6.92																																																	
3/4	12.70																																																	
7/8	19.00																																																	
1	28.00																																																	
Prod. # & Size	Wt./C lbs.																																																	
ES-145-3/8	5.5																																																	
ES-145-1/2	6.0																																																	
Size	Wt./C lbs.																																																	
1/4	.93																																																	
5/16	1.60																																																	
3/8	2.65																																																	
1/2	5.83																																																	
5/8	10.80																																																	
<p>E-147 Flat Steel Washer</p>  <table border="1"> <thead> <tr> <th>Size</th> <th>Wt./C lbs.</th> </tr> </thead> <tbody> <tr> <td>1/4</td> <td>.67</td> </tr> <tr> <td>5/16</td> <td>1.11</td> </tr> <tr> <td>3/8</td> <td>1.49</td> </tr> <tr> <td>1/2</td> <td>3.85</td> </tr> <tr> <td>5/8</td> <td>7.69</td> </tr> <tr> <td>3/4</td> <td>9.89</td> </tr> <tr> <td>7/8</td> <td>15.40</td> </tr> </tbody> </table>	Size	Wt./C lbs.	1/4	.67	5/16	1.11	3/8	1.49	1/2	3.85	5/8	7.69	3/4	9.89	7/8	15.40	<p>EF-147 Fender Washer</p>  <table border="1"> <thead> <tr> <th>Size</th> <th>A</th> <th>B</th> <th>Wt./C lbs.</th> </tr> </thead> <tbody> <tr> <td>1/4</td> <td>1-1/4</td> <td>5/16</td> <td>3.1</td> </tr> <tr> <td>3/8</td> <td>1-1/2</td> <td>7/16</td> <td>2.9</td> </tr> <tr> <td>1/2</td> <td>2</td> <td>9/16</td> <td>5.0</td> </tr> </tbody> </table>	Size	A	B	Wt./C lbs.	1/4	1-1/4	5/16	3.1	3/8	1-1/2	7/16	2.9	1/2	2	9/16	5.0	<p>E-148 Lock Washer</p>  <table border="1"> <thead> <tr> <th>Size</th> <th>Wt./C lbs.</th> </tr> </thead> <tbody> <tr> <td>1/4</td> <td>.26</td> </tr> <tr> <td>5/16</td> <td>.39</td> </tr> <tr> <td>3/8</td> <td>.50</td> </tr> <tr> <td>1/2</td> <td>1.09</td> </tr> <tr> <td>5/8</td> <td>2.57</td> </tr> </tbody> </table>	Size	Wt./C lbs.	1/4	.26	5/16	.39	3/8	.50	1/2	1.09	5/8	2.57				
Size	Wt./C lbs.																																																	
1/4	.67																																																	
5/16	1.11																																																	
3/8	1.49																																																	
1/2	3.85																																																	
5/8	7.69																																																	
3/4	9.89																																																	
7/8	15.40																																																	
Size	A	B	Wt./C lbs.																																															
1/4	1-1/4	5/16	3.1																																															
3/8	1-1/2	7/16	2.9																																															
1/2	2	9/16	5.0																																															
Size	Wt./C lbs.																																																	
1/4	.26																																																	
5/16	.39																																																	
3/8	.50																																																	
1/2	1.09																																																	
5/8	2.57																																																	

SECTION 2 Threaded Products and Hardware — Series 100

Nuts and Bolts

E-142 Hex Head Cap Screw



Size	Wt./C lbs.
1/4 x 1	1.74
1/4 x 1-1/2	2.43
3/8 x 1	4.17
3/8 x 1-1/2	5.64
1/2 x 15/16	8.94
1/2 x 1-1/2	10.00

See Price Sheet For Additional Sizes

E-149 Slotted Hex Indented Head Machine Screw



Size	Wt./C lbs.
1/4 x 3/4	1.40
1/4 x 1	1.70
5/16 x 1-1/4	3.40
3/8 x 1-1/4	5.30

E-120

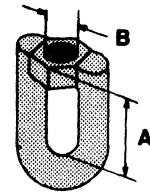

Prod. #	A	B	Wt./C lbs.	Design Load lbs.
E-120-3/8	1-3/8	3/8	15	1000
E-120-1/2	1-1/2	1/2	25	1800

E-122

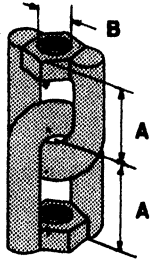

Prod. #	A	B	Wt./C lbs.	Design Load lbs.
E-122-3/8	1-3/8	3/8	28	1000
E-122-1/2	1-1/2	1/2	48	1800

E-130

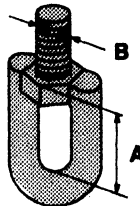

Prod. #	A	B	Wt./C lbs.	Design Load lbs.
E-130-3/8	1-3/8	3/8	23	1000
E-130-1/2	1-1/2	1/2	28	1800

E-131

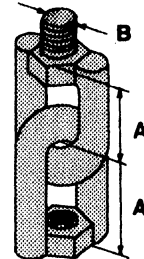

Prod. #	A	B	Wt./C lbs.	Design Load lbs.
E-131-3/8	1-3/8	3/8	25	1000
E-131-1/2	1-1/2	1/2	52	1800

E-150-S Hex Head Lag Bolt

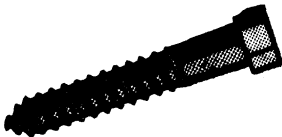

Screw Size	3/8	1/2
Drill Size	1/4	11/32

See Price Sheet for Length.

H-104 Hanger Rod Continuous Thread

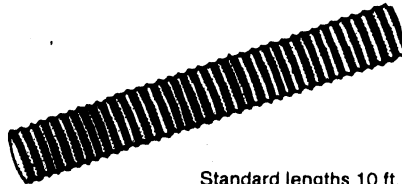

Standard lengths 10 ft.

E-151 Coach Screw Rod

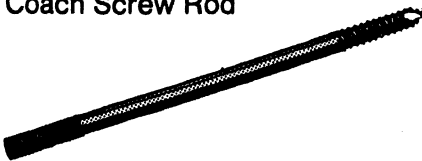

Machine threaded opposite end, carbon steel. Order by Prod. #, rod, size and rod length.

STANDARD THREAD LENGTHS (inches) - LOADS

Rod Size	Standard Rod Lengths
3/8	3 1/2, 4, 6, 8, 10, 12, 14
1/2	4, 8, 10

NATIONAL COARSE THREAD

Size	Threads per inch	lbs./100 ft.	Design Load lbs.
1/4	20	12.5	150
3/8	16	29	610
1/2	13	53.5	1130
5/8	11	85	1810
3/4	10	123	2710
7/8	9	130	3770
1	8	214	4960

Threaded Products and Hardware — Series 100 SECTION 2

Nuts and Bolts

H-119 Standard Rod Coupling

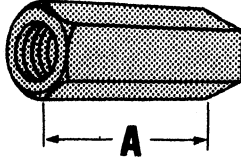

Standard finish GOLDGUARD

Prod. #	Rod Size	A	Wt./C lbs.
H-119-1/4	1/4	1-3/4	9
H-119-5/16	5/16	1-3/4	7
H-119-3/8	3/8	1-3/4	10
H-119-1/2	1/2	1-3/4	18
H-119-5/8	5/8	2-1/8	23
H-119-3/4	3/4	2-1/4	21
H-119-7/8	7/8	2-1/2	55
H-119-1	1	2-3/4	68

H-119 Reducing Rod Coupling

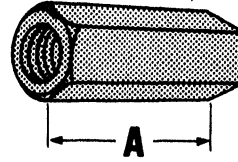

Standard finish GOLDGUARD

Prod. #	Rod Sizes	A	Wt./C lbs.
H-119	1/4 to 3/8	1	10
H-119	3/8 to 1/2	1-1/4	12
H-119	1/2 to 5/8	1-1/4	22
H-119	5/8 to 3/4	1-1/2	26
H-119	3/4 to 7/8	1-5/8	32

H-115 Standard U-Bolt

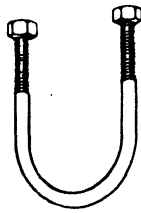

Sizes through 4" furnished with one hex nut per leg.

Sizes 5" and above furnished with two hex nuts per leg.

Complies with Fed. spec. WW-H-171E and SP-69 Type 24.

Order by Prod. #, pipe size, finish.

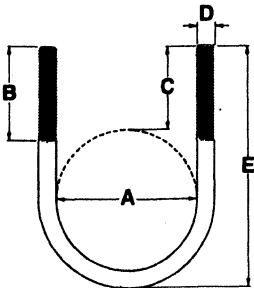

DIMENSIONS (Inches) - WEIGHTS - LOADS

Pipe Size	A	B	C	D	E	Wt./C lbs.	Design Load lbs.
1/2	15/16	13/4	1 1/2	5/16	2 3/4	13	900
3/4	1 1/8	1 3/4	1 5/8	5/16	3 1/16	15	1200
1	1 3/8	1 7/8	1 5/8	5/16	3 5/16	16	1500
1-1/4	1 23/32	1 3/4	1 15/32	5/16	3 1/2	17	1500
1-1/2	2	1 3/4	1 7/16	5/16	3 3/4	18	1500
2	2 7/16	2 1/8	1 7/8	3/8	4 1/16	32	1980
2-1/2	2 15/16	2 1/8	1 13/16	3/8	5 1/8	34	2400
3	3 9/16	2	1 3/4	3/8	5 11/16	38	2400
3-1/2	4 3/32	2	1 23/32	3/8	6 3/16	40	2400
4	4 19/32	2 1/4	1 31/32	3/8	6 5/16	46	2400
5	5 5/8	3	2 7/32	1/2	8 5/16	101	2400
6	6 3/4	3 3/4	2 13/16	5/8	10 1/8	197	2400
8	8 3/4	3 3/4	2 13/16	5/8	12 1/8	233	2400
10	10 7/8	4	3	3/4	14 9/16	491	3240
12	12 7/8	4 1/4	3 1/4	7/8	16 5/16	773	4500

MATERIAL

Superstrut fittings and brackets are manufactured from hot rolled carbon steel or pickled and oiled strip steel.

DIMENSIONS

The following standard dimensions apply to all fittings except as indicated on the individual drawings.

Hole spacing	13/16" from end of fitting
Hole spacing	1-7/8" centers
Hole size	9/16" diameter
Material	1-5/8" wide
Material	1/4" thick

APPLICATION ILLUSTRATIONS

Parts drawings illustrate a typical use for the fitting, and in many cases other uses for the part are appropriate.

DESIGN DATA

Load ratings where shown provide for a safety factor of 2-1/2. Ratings vary when used with 12, 14, or 16 ga. channel and are shown for each channel material.

STANDARD FINISH

Saudi Superstrut fittings are electro-galvanized after fabrication. This protective finish conforms to ASTM specification A-164-71, Type LS.

NUTS AND BOLTS REQUIRED

Unless otherwise noted, nuts and bolts for use with fittings and brackets should be ordered separately.

The standard bolt for a 9/16" hole is a 1/2" hex head cap screw 15/16" long. The 15/16" length may be used with all series channel.

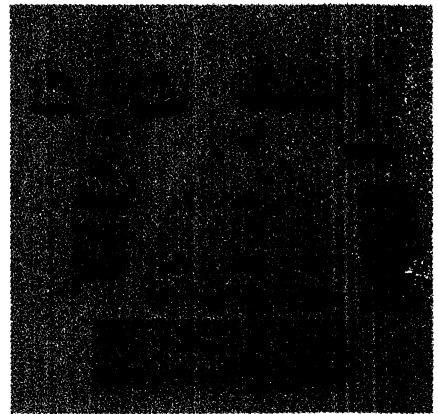
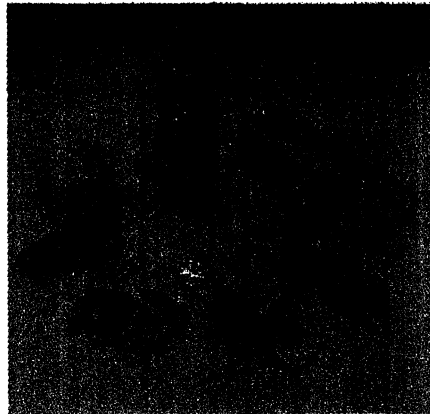
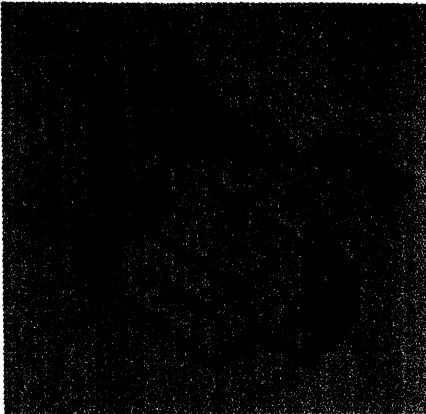



	PAGE
•90° Angle Fittings	11
•Flat Plate Fittings	12
•Angular Fittings	14
•"Z" Shape Fittings	14
•Wing Shape Fittings	14

	PAGE
•"U" Shape Fittings	16
•Post Bases	17
•Special Applications	17
•Brackets	18

Fittings and Brackets — Series 200

SECTION 3

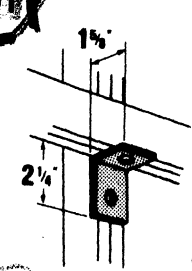
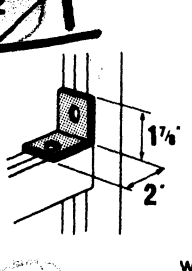
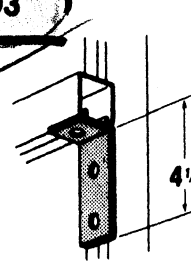
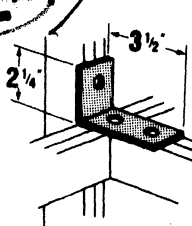
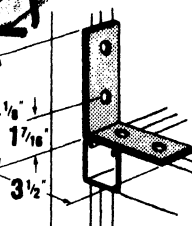
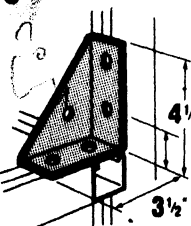
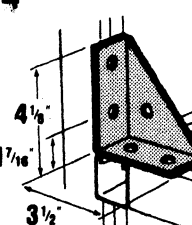
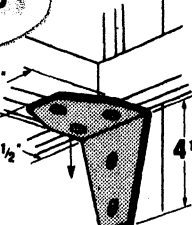
90° Angle Fittings

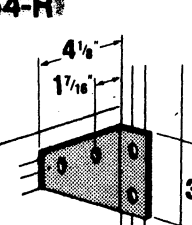
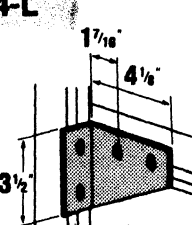
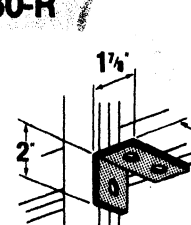
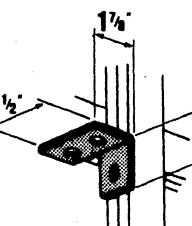
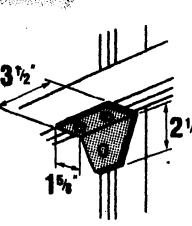
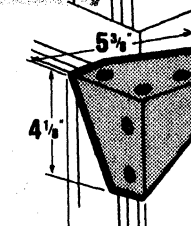
<p>AB-201</p>  <p>wt./C 35 lbs.</p>	<p>AB-202</p>  <p>wt./C 35 lbs.</p>	<p>AB-203</p>  <p>wt./C 58 lbs.</p>															
<p>AB-204</p>  <p>wt./C 58 lbs.</p>	<p>AB-205</p>  <p>wt./C 78 lbs.</p>	<p>AB-213</p>  <p>wt./C 125 lbs.</p>															
<p>AB-214</p>  <p>wt./C 125 lbs.</p>	<p>AB-216</p>  <p>wt./C 135 lbs.</p>	<p>AB-252 1 thru 4</p>  <table border="1"> <thead> <tr> <th>Prod. #</th> <th>A</th> <th>Wt./C lbs.</th> </tr> </thead> <tbody> <tr> <td>AB-252-1</td> <td>3-7/8</td> <td>61</td> </tr> <tr> <td>AB-252-2</td> <td>5-7/8</td> <td>84</td> </tr> <tr> <td>AB-252-3</td> <td>7-7/8</td> <td>107</td> </tr> <tr> <td>AB-252-4</td> <td>9-7/8</td> <td>130</td> </tr> </tbody> </table>	Prod. #	A	Wt./C lbs.	AB-252-1	3-7/8	61	AB-252-2	5-7/8	84	AB-252-3	7-7/8	107	AB-252-4	9-7/8	130
Prod. #	A	Wt./C lbs.															
AB-252-1	3-7/8	61															
AB-252-2	5-7/8	84															
AB-252-3	7-7/8	107															
AB-252-4	9-7/8	130															
<p>AB-254-R</p>  <p>wt./C 105 lbs.</p>	<p>AB-254-L</p>  <p>wt./C 105 lbs.</p>	<p>AB-260-R</p>  <p>wt./C 58 lbs.</p>															
<p>AB-260-L</p>  <p>wt./C 58 lbs.</p>	<p>AB-274</p>  <p>wt./C 70 lbs.</p>	<p>AB-284-R</p>  <p>wt./C 230 lbs.</p>															

Standard Dimensions

Hole Spacing 13/16" From End
 Hole Spacing 1-7/8" Centers
 Hole Size 9/16" Diam.
 Material 1-5/8" Width
 Material 1/4" Thick

20,6375
 47,625
 14,2875
 41,275
 6

SECTION 3

Fittings and Brackets — Series 200

90° Angle Fittings

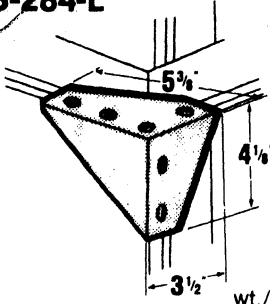
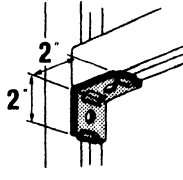
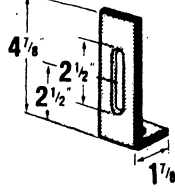
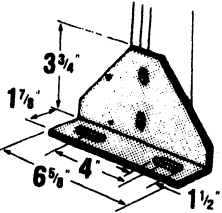
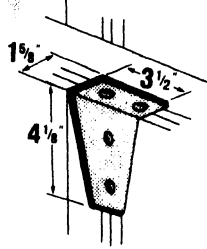
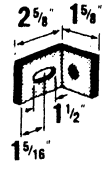
<p>AB-284-L</p>  <p>wt./C 230 lbs.</p>	<p>AB-299</p>  <p>wt./C 40 lbs.</p>	<p>X-201</p>  <p>wt./C 65 lbs.</p>
<p>X-204</p>  <p>wt./C 190 lbs.</p>	<p>X-289</p>  <p>wt./C 105 lbs.</p>	<p>X-299</p>  <p>wt./C 38 lbs.</p>

Flat Plate Fittings

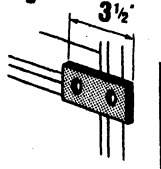
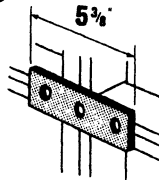
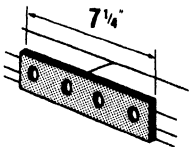
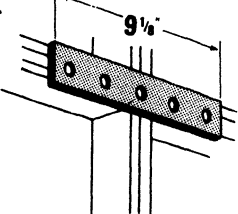
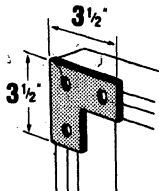
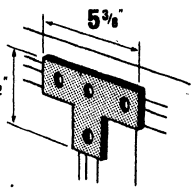
<p>AB-206</p>  <p>wt./C 35 lbs.</p>	<p>AB-207</p>  <p>wt./C 52 lbs.</p>	<p>X-207</p>  <p>wt./C 78 lbs.</p>
<p>X-208</p>  <p>wt./C 88 lbs.</p>	<p>AB-219</p>  <p>wt./C 53 lbs.</p>	<p>AB-220</p>  <p>wt./C 78 lbs.</p>

Flat Plate Fittings

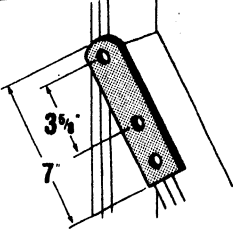
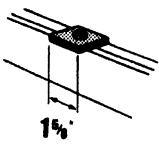
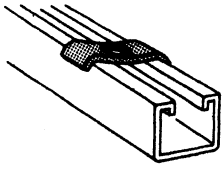
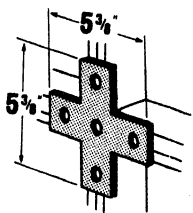
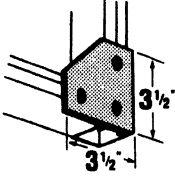
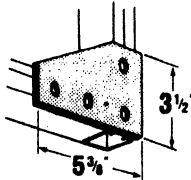
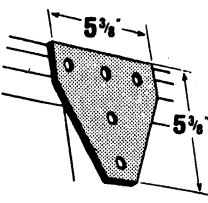
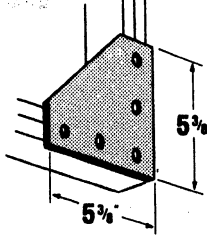
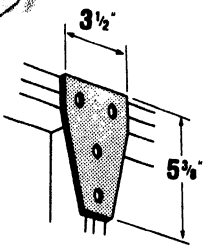
<p>AB-240</p>  <p>wt./C 69 lbs.</p>	<p>AB-241</p>  <table border="1"> <thead> <tr> <th>Prod. #</th> <th>Bolt Size</th> <th>Wt./C lbs.</th> </tr> </thead> <tbody> <tr> <td>AB-241-1/4</td> <td>1/4</td> <td>18</td> </tr> <tr> <td>AB-241-5/16</td> <td>5/16</td> <td>18</td> </tr> <tr> <td>AB-241-3/8</td> <td>3/8</td> <td>18</td> </tr> <tr> <td>AB-241-1/2</td> <td>1/2</td> <td>17</td> </tr> <tr> <td>AB-241-5/8</td> <td>5/8</td> <td>15</td> </tr> <tr> <td>AB-241-3/4</td> <td>3/4</td> <td>14</td> </tr> </tbody> </table>	Prod. #	Bolt Size	Wt./C lbs.	AB-241-1/4	1/4	18	AB-241-5/16	5/16	18	AB-241-3/8	3/8	18	AB-241-1/2	1/2	17	AB-241-5/8	5/8	15	AB-241-3/4	3/4	14	<p>AB-242</p>  <p>For use with either 3/8" or 1/2" hanger rod.</p> <p>wt./C 9 lbs.</p>
Prod. #	Bolt Size	Wt./C lbs.																					
AB-241-1/4	1/4	18																					
AB-241-5/16	5/16	18																					
AB-241-3/8	3/8	18																					
AB-241-1/2	1/2	17																					
AB-241-5/8	5/8	15																					
AB-241-3/4	3/4	14																					
<p>AB-253</p>  <p>wt./C 97 lbs.</p>	<p>AB-255</p>  <p>wt./C 70 lbs.</p>	<p>AB-257</p>  <p>wt./C 105 lbs.</p>																					
<p>AB-261</p>  <p>wt./C 148 lbs.</p>	<p>AB-263</p>  <p>wt./C 150 lbs.</p>	<p>AB-265</p>  <p>wt./C 105 lbs.</p>																					

Standard Dimensions

Hole Spacing
Hole Spacing
Hole Size
Material
Material

13/16" From End
1-7/8" Centers
9/16" Diam.
1-5/8" Width
1/4" Thick

SECTION 3

Fittings and Brackets — Series 200

Angular Fittings

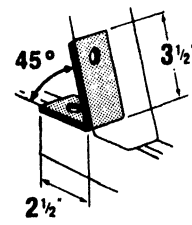
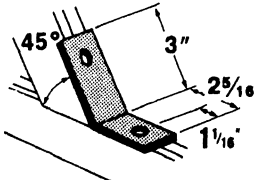
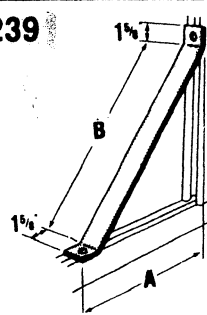
<p>AB-225</p>  <p>wt./C 58 lbs.</p>	<p>AB-227</p>  <p>wt./C 58 lbs.</p>	<p>AB-239</p>  <table border="1"> <thead> <tr> <th>Prod. #</th> <th>A</th> <th>B</th> <th>Wt./C lbs.</th> </tr> </thead> <tbody> <tr> <td>AB-239-1</td> <td>7-13/16</td> <td>8-1/2</td> <td>148</td> </tr> <tr> <td>AB-239-2</td> <td>13-3/4</td> <td>17</td> <td>255</td> </tr> <tr> <td>AB-239-3</td> <td>19-3/4</td> <td>25-1/2</td> <td>363</td> </tr> </tbody> </table>	Prod. #	A	B	Wt./C lbs.	AB-239-1	7-13/16	8-1/2	148	AB-239-2	13-3/4	17	255	AB-239-3	19-3/4	25-1/2	363
Prod. #	A	B	Wt./C lbs.															
AB-239-1	7-13/16	8-1/2	148															
AB-239-2	13-3/4	17	255															
AB-239-3	19-3/4	25-1/2	363															

"Z" Shape Fittings

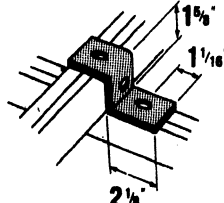
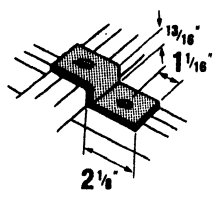
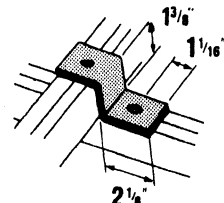
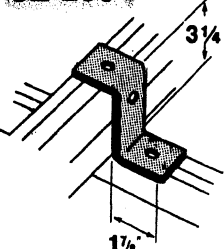
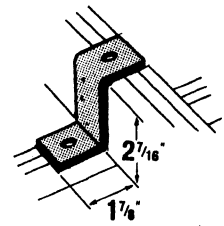
<p>A-209</p>  <p>For attaching "A" series channel</p> <p>wt./C 55 lbs.</p>	<p>B-209</p>  <p>For attaching "B" series channel</p> <p>wt./C 43 lbs.</p>	<p>C-209</p>  <p>For attaching "C" series channel</p> <p>wt./C 49 lbs.</p>
<p>CZ-209</p>  <p>For attaching "A" series double</p> <p>wt./C 70 lbs.</p>	<p>EZ-209</p>  <p>For attaching "E" series channel</p> <p>wt./C 70 lbs.</p>	

Wing Shape Fittings

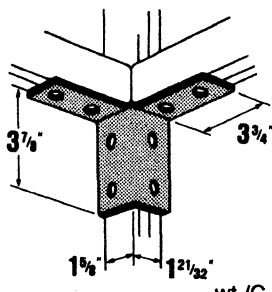
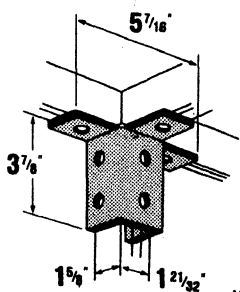
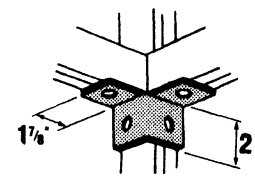
<p>A-217</p>  <p>wt./C 155 lbs.</p>	<p>A-218</p>  <p>wt./C 177 lbs.</p>	<p>AW-204</p>  <p>wt./C 76 lbs.</p>
-------------------------------------------------------------------------------------------------------------------------------	-------------------------------------------------------------------------------------------------------------------------------	---------------------------------------------------------------------------------------------------------------------------------

4 Standard Dimensions
 Hole Spacing 13/16" From End
 Hole Spacing 1-7/8" Centers
 Hole Size 9/16" Diam.
 Material 1-5/8" Width
 Material 1/4" Thick

Wing Shape Fittings

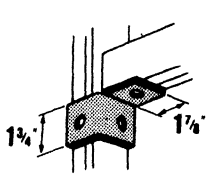
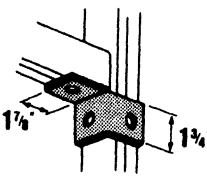
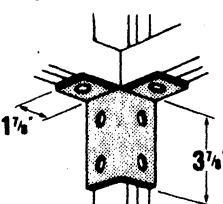
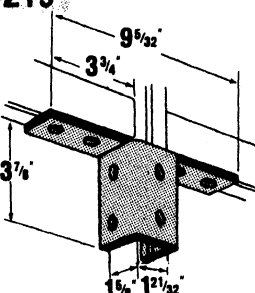
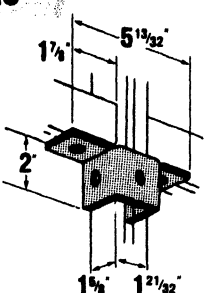
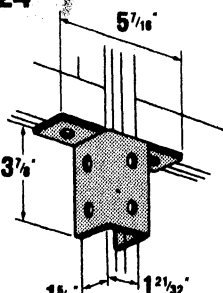
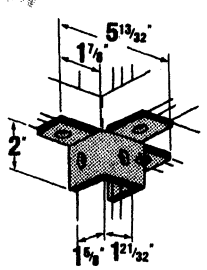
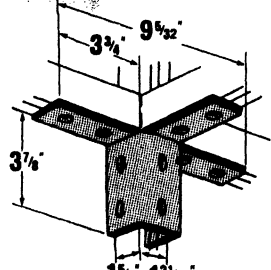
<p>AW-205-L</p>  <p>wt./C 59 lbs.</p>	<p>AW-205-R</p>  <p>wt./C 59 lbs.</p>	<p>AW-214</p>  <p>wt./C 115 lbs.</p>
<p>AW-219</p>  <p>wt./C 187 lbs.</p>	<p>AW-220</p>  <p>wt./C 90 lbs.</p>	<p>AW-224</p>  <p>wt./C 147 lbs.</p>
<p>AW-226</p>  <p>wt./C 113 lbs.</p>	<p>AW-228</p>  <p>wt./C 230 lbs.</p>	

Standard Dimensions
 Hole Spacing 13/16" From End
 Hole Spacing 1-7/8" Centers
 Hole Size 9/16" Diam.
 Material 1-5/8" Width
 Material 1/4" Thick

SECTION 3

Fittings and Brackets — Series 200

“U” Shape Fittings

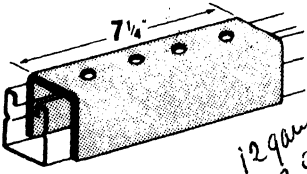
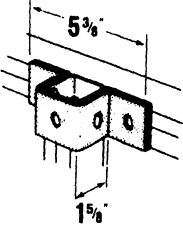
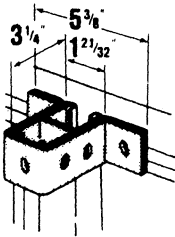
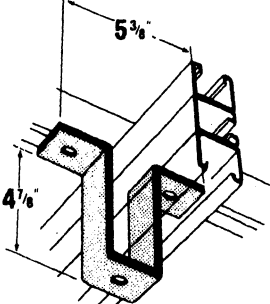
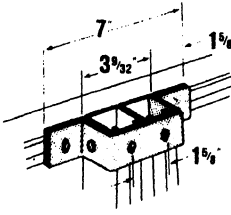
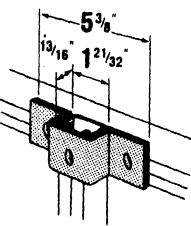
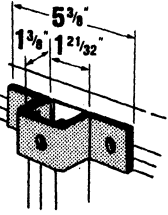
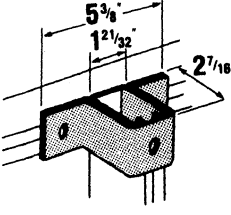
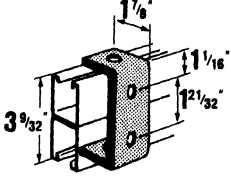
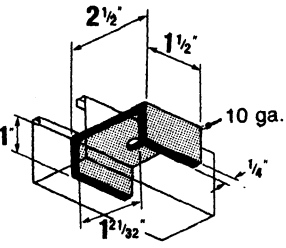
<p>A-208</p>  <p>For "A" series channel. wt./C 257 lbs.</p>	<p>A-210</p>  <p>For attaching "A" series channel wt./C 88 lbs.</p>	<p>A-211</p>  <p>For attaching "A" series double channel wt./C 128 lbs.</p>												
<p>AN-211</p>  <p>wt./C 181 lbs.</p>	<p>A-212</p>  <p>wt./C 113 lbs.</p>	<p>B-210</p>  <p>For attaching "B" series channel wt./C 65 lbs.</p>												
<p>C-210</p>  <p>For attaching "C" series channel wt./C 77 lbs.</p>	<p>E-210</p>  <p>For attaching "E" series channel wt./C 112 lbs.</p>	<p>AB-245</p>  <p>wt./C 70 lbs.</p>												
<p>AB-288</p>  <table border="1" data-bbox="132 1664 419 1792"> <thead> <tr> <th>Prod. #</th> <th>Bolt Size</th> <th>Wt./C lbs.</th> </tr> </thead> <tbody> <tr> <td>AB-288</td> <td>3/8</td> <td>37</td> </tr> <tr> <td>AB-288</td> <td>1/2</td> <td>37</td> </tr> <tr> <td>AB-288</td> <td>5/8</td> <td>37</td> </tr> </tbody> </table>	Prod. #	Bolt Size	Wt./C lbs.	AB-288	3/8	37	AB-288	1/2	37	AB-288	5/8	37		
Prod. #	Bolt Size	Wt./C lbs.												
AB-288	3/8	37												
AB-288	1/2	37												
AB-288	5/8	37												

SECTION 3

Fittings and Brackets - Series 200

Post Bases

<p>AP-206</p> <p>(134.65 Kgs.) wt./C 297 lbs.</p>	<p>AP-231</p> <p>(144.67 Kgs.) wt./C 319 lbs.</p>	<p>AP-232</p> <p>(174.15 Kgs.) wt./C 384 lbs.</p>
<p>AP-233</p> <p>(151 Kgs.) wt./C 333 lbs.</p>	<p>AP-235</p> <p>(181 Kgs.) wt./C 400 lbs.</p>	

Special Application Fittings

<p>AN-270 1 thru 5</p> <table border="1"> <thead> <tr> <th>Prod.#</th> <th>A in. (mm)</th> <th>B in (mm)</th> <th>Wt./C lbs. (Kgs.)</th> </tr> </thead> <tbody> <tr> <td>AN-270-1</td> <td>2-3/8 (60)</td> <td>6 (51)</td> <td>113 (51)</td> </tr> <tr> <td>AN-270-2</td> <td>4-3/8 (111)</td> <td>8 (68.5)</td> <td>151 (68)</td> </tr> <tr> <td>AN-270-3</td> <td>6-3/8 (162)</td> <td>10 (90)</td> <td>199 (90)</td> </tr> <tr> <td>AN-270-4</td> <td>8-3/8 (213)</td> <td>12 (111.5)</td> <td>246 (111)</td> </tr> <tr> <td>AN-270-5</td> <td>10-3/8 (263.5)</td> <td>14 (133)</td> <td>293 (133)</td> </tr> </tbody> </table>	Prod.#	A in. (mm)	B in (mm)	Wt./C lbs. (Kgs.)	AN-270-1	2-3/8 (60)	6 (51)	113 (51)	AN-270-2	4-3/8 (111)	8 (68.5)	151 (68)	AN-270-3	6-3/8 (162)	10 (90)	199 (90)	AN-270-4	8-3/8 (213)	12 (111.5)	246 (111)	AN-270-5	10-3/8 (263.5)	14 (133)	293 (133)	<p>FA-206</p> <p>Use to join 1-5/8" (41) channel to 13/16" (20.6) wide channel.</p> <p>(6 Kgs.) wt./C 13 lbs.</p>	<p>Q-252-1-1/4</p> <p>(13.34 KN) Load 3000 lbs. (138.30 Kgs.) wt./C 305 lbs.</p> <p>For 1 1/4" (32 mm) standard pipe.</p>
Prod.#	A in. (mm)	B in (mm)	Wt./C lbs. (Kgs.)																							
AN-270-1	2-3/8 (60)	6 (51)	113 (51)																							
AN-270-2	4-3/8 (111)	8 (68.5)	151 (68)																							
AN-270-3	6-3/8 (162)	10 (90)	199 (90)																							
AN-270-4	8-3/8 (213)	12 (111.5)	246 (111)																							
AN-270-5	10-3/8 (263.5)	14 (133)	293 (133)																							
<p>Q-252-2</p> <p>(13.34 KN) Load 3000 lbs. (183.62 Kgs.) wt./C 405 lbs.</p> <p>For 2" (51 mm) standard pipe.</p>																										

Note : Metric equivalent in ().
Design Data Safety Factor 2-1/2
: **Standard Dimensions:**
Hole spacing (21) 13/16" From End
Hole spacing (47.6) 1-7/8" Centers
Hole size (14.3) 9/16" Diam.
Material (41.3) 1-5/8" width
Material (6.3) 1/4" Thick

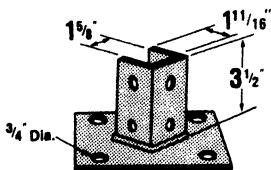
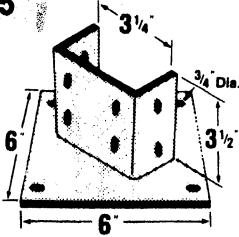

Post Bases

<p>AP-232</p>  <p>wt./C 384 lbs.</p>	<p>AP-235</p>  <p>wt./C 400 lbs.</p>	
------------------------------------------------------------------------------------------------------------------------------	------------------------------------------------------------------------------------------------------------------------------	--

Special Application Fittings

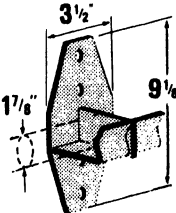
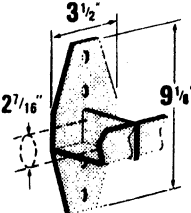
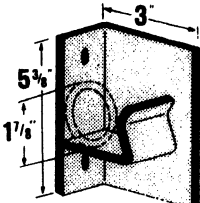
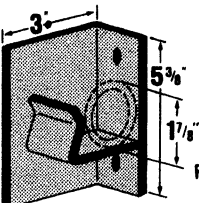
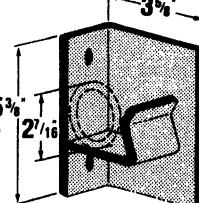
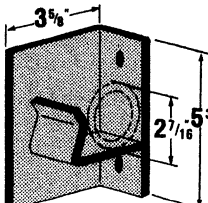
	<p>Q-252-1-1/4</p>  <p>For 1 1/4" standard pipe</p> <p>Load 3000 lbs. wt./C 305 lbs.</p>	<p>Q-252-2</p>  <p>For 2" standard pipe</p> <p>Load 3000 lbs. wt./C 405 lbs.</p>
<p>Q-253</p>  <p>For 1 1/4" standard pipe</p> <p>Load 2000 lbs. wt./C 205 lbs.</p>	<p>Q-254</p>  <p>For 1 1/4" standard pipe</p> <p>Load 2000 lbs. wt./C 206 lbs.</p>	<p>Q-255</p>  <p>For 2" standard pipe</p> <p>Load 2000 lbs. wt./C 234 lbs.</p>
<p>Q-256</p>  <p>For 2" standard pipe</p> <p>Load 2000 lbs. wt./C 234 lbs.</p>		

<p>Standard Dimensions</p>	<p>Hole Spacing Hole Spacing Hole Size Material Material</p>	<p>13/16" From End 1-7/8" Centers 9/16" Diam. 1-5/8" Width 1/4" Thick</p>	<p>Design Data Safety Factor 2-1/2 17</p>
----------------------------	------------------------------------------------------------------------------	-------------------------------------------------------------------------------------------	--------------------------------------------------

SECTION 3

Fittings and Brackets — Series 200

Special Application Fittings

AN-270
1 thru 5

Prod. #	A	B	Wt./C lbs.
AN-270-1	2-3/8	6	113
AN-270-2	4-3/8	8	151
AN-270-3	6-3/8	10	199
AN-270-4	8-3/8	12	246
AN-270-5	10-3/8	14	293

TS-272
Track Support

Requires 3/8" x 2-1/2" bolt and nut (not included).

Design load: 1200 lbs.
wt./C 104 lbs.

TS-273
Track Support

For use over channel splice
Requires 3/8" x 2-1/2" bolt and nut (not included).

Design load: 2500 lbs.
wt./C 228 lbs.

Brackets

S-201-L and R

R as shown - L opposite hand.
12 ga. steel

A	B	C	Wt./C lbs.
6	1-15/16	3	67
8	2-7/16	5	92
10	2-15/16	7	120

Design Uniform Load/lbs.
A-1200 300
A-1400 250

S-201-L and R

R as shown - L opposite hand.
12 ga. steel

A	B	C	Wt./C lbs.
12	3-7/16	3	152
14	3-15/16	4	173
16	4-7/16	5	223
18	4-15/16	6	266
20	5-7/16	7	308

Design Uniform Load/lbs.
A-1200 300
A-1400 250

S-204

Design Uniform Load/lbs.
A-1200 800
A-1400 600

wt./C 174 lbs.

S-205

Design Uniform Load/lbs.
A-1200 800
A-1400 600

wt./C 264 lbs.

S-217

Design Uniform Load/lbs.
A-1200 900
A-1400 800
A-1400 450

wt./C 264 lbs.

S-218

Design Uniform Load/lbs.
A-1200 900
A-1400 800

wt./C 295 lbs.

Brackets

S-222

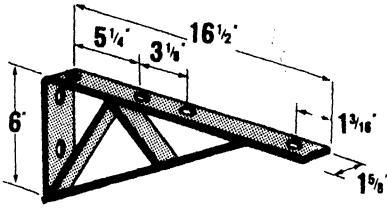

Design Uniform Load/lbs.

A-1200	1200
A-1400	900

wt./C 385 lbs.

S-226

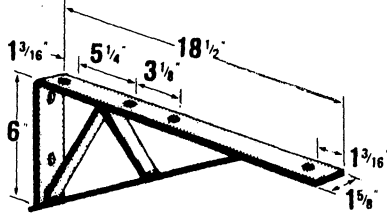

Design Uniform Load/lbs.

A-1200	1200
A-1400	900
A-1400	600

wt./C 421 lbs.

S-236

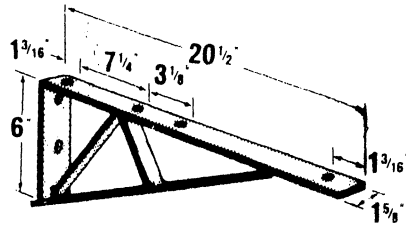

Design Uniform Load/lbs.

A-1200	1000
A-1400	800

wt./C 744 lbs.

S-247

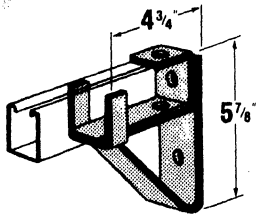

Hole 9/16"

Design Moment (channel upright as shown) When Supported By

A-1200	6300 inch lbs.
A-1400	4400 inch lbs.

Applies to fitting only not to the arm.

For:
A-1200 B-1202
A-1400 B-1402
wt./C 229 lbs.

S-248

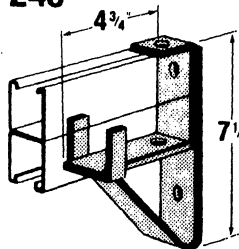

Hole 9/16"

Design Moment (channel upright as shown) When Supported By

A-1200	13000 inch lbs.
A-1400	9100 inch lbs.

Applies to fitting only not to the arm.

For:
A-1202
A-1402
wt./C 272 lbs.

S-250

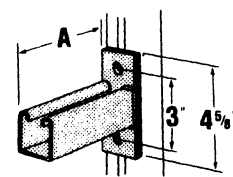

May be installed inverted with no change in load ratings.

A	Uniform Load lbs.	Wt./C lbs.
6	1800	150
12	1000	250
18	700	350
24	500	450

S-251

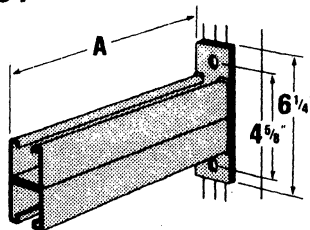

A	Uniform Load lbs.	Wt./C lbs.
12	2000	514
18	1300	714
24	1000	914
30	800	1114
36	650	1314

S-256

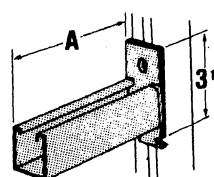

When installed in inverted position reduce load rating 40%.

A	Uniform Load lbs.	Wt./C lbs.
6	1200	151
12	600	251
18	400	351
24	300	451

Standard Dimensions
Hole Spacing 13/16" From End
Hole Spacing 1-7/8" Centers
Hole Size 9/16" Diam.
Material 1-5/8" Width

Design Data Safety Factor 2-1/2

MATERIAL

Superstrut continuous insert channel is manufactured from 12 gauge pickled and oiled strip steel in three basic sizes as follows:

Prod. # A-300	1-5/8 x 1-5/8 dim.	7/8" slot
Prod. # B-300	1-5/8 x 13/16 dim.	7/8" slot

A-300 series concrete inserts are most commonly used due to dimensional compatibility with standard construction practice.

Standard lengths are 10 ft. and 20 ft. and shorter lengths are available for a small additional cutting charge.

ASSEMBLED
INSERTS

Assembled inserts made from these channels in any length from 12" to 20 ft. are available in 3 options as follows:

1. Cut to length with end caps installed - Prod. # 301
2. Cut to length with end caps and styrene closure strip installed - Prod. # 302
3. Standard lengths (Prod. # 300) ordered with styrene closure strip and end caps (Prod. # 804) for field assembly.

APPLICATION

For casting into concrete walls, floors or ceilings to provide for attachment anywhere along the continuous slot.

DESIGN DATA

Load ratings as shown have a safety factor of 3 in 3000 lb. hard rock concrete. Where "good concrete" does not exist the load ratings shall not apply.

STANDARD
FINISH

Saudi Superstrut channel is manufactured from pre-galvanized steel. The steel is hot-dipped galvanized at the mill prior to cutting, punching, or forming. The coating is in conformance with ASTM specification A-525 (G90).

Saudi Superstrut fittings and threaded products are electro-galvanized after fabrication. This protective finish conforms to ASTM specification A-164-71, Type LS (RS for threads).

NUTS - BOLTS -
FITTINGS

The A & B 300 series insert channels have the same dimensions as A & B 1200 (12 ga.) standard channels and the same fittings and nuts are standard for both.

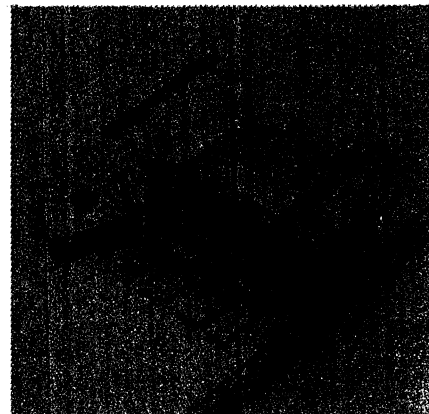
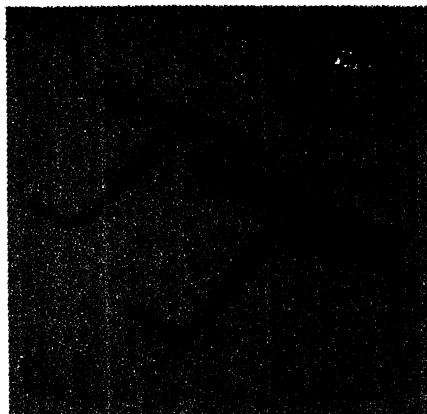
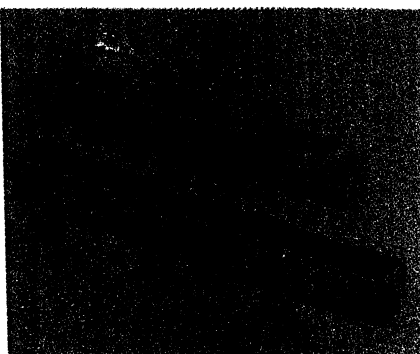

B-302

Insert with end caps and foam filler strip installed.

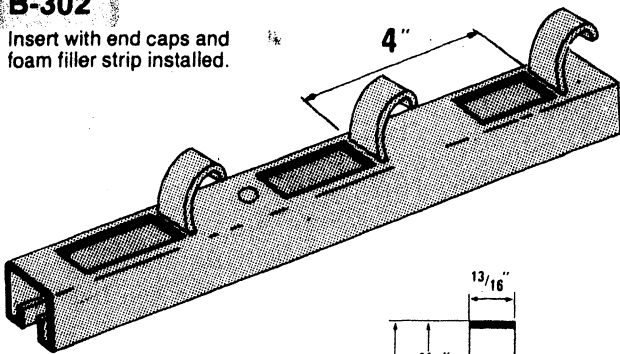

B-804 end cap

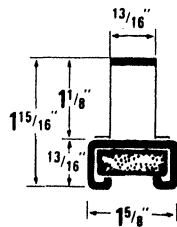

Foam Filler

Material	Wt.	Design Load lbs.
B-302 Series Insert Channel 12 ga. steel	1.36 lbs./ft.	2000 lbs. per foot in 3000 lbs. hard rock concrete with a safety factor of 3.
B-804 End caps 12 ga. steel	5 lbs./C	

Standard lengths 10' and 20'. Length tolerance 3/16". Assemblies available in any length from 12" to 20". Consult factory.

A-302

Insert with end caps and foam filler installed.

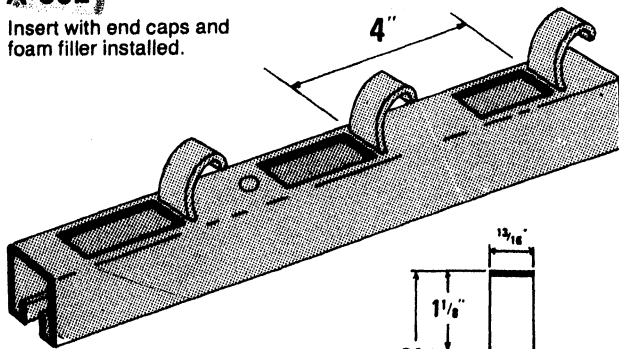

A-804 end cap

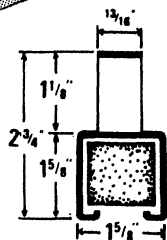

Foam Filler

Material	Wt.	Design Load lbs.
A-302 Series Insert Channel 12 ga. steel	1.81 lbs./ft.	2000 lbs. per foot in 3000 lbs. hard rock concrete with a safety factor of 3.
A-804 End caps 12 ga. steel	8 lbs./C	

Standard lengths 10' and 20'. Length tolerance 3/16". Assemblies available in any length from 12" to 20". Consult factory.

450
End Cap

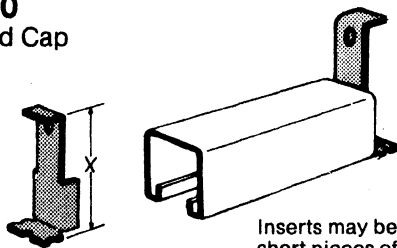

Inserts may be assembled from short pieces of channel by use of end caps.
Order closure strip separately.

DIMENSIONS (inches) - WEIGHTS

Prod. #	For Channel	"X"	Material	Wt./C lbs.
B-450	B-1200	2-3/8	12 ga.	22
A-450	C-1200	3	12 ga.	30

Do not come in pairs, order number of total pieces required.

SECTION 4

Concrete Inserts — Series 300/400

452
Spot Insert
TOP IS DEEP DRAWN CUP

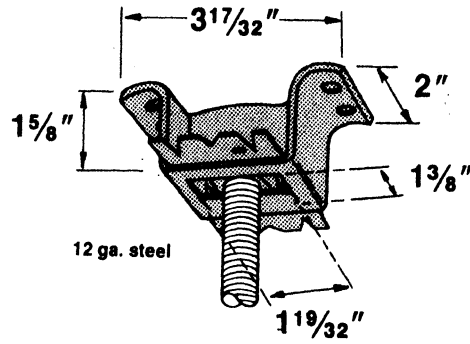
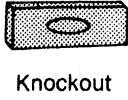

An insert with a knockout saves covering the opening. Accommodates hanger rod size from 1/4" through 7/8" by means of an AB-102 insert nut.

Design load: 1900 lbs. in 3000 lb. hard rock concrete with a safety factor of 3. Order AB-102 nut separately.

Available in ELECTRO-GALVANIZED Finish.
wt./C 52 lbs.

AB-102
Unhardened Square Nut

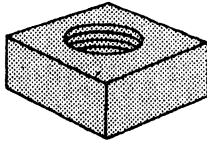

For use with Spot Insert
Prod. #452.

Prod. #	Size	Wt./C lbs.
AB-102-1/4	1/4	10.5
AB-102-3/8	3/8	13.25
AB-102-1/2	1/2	14
AB-102-5/8	5/8	13.5
AB-102-3/4	3/4	12
AB-102-7/8	7/8	10.5

454 R
Removable
Closure Strip

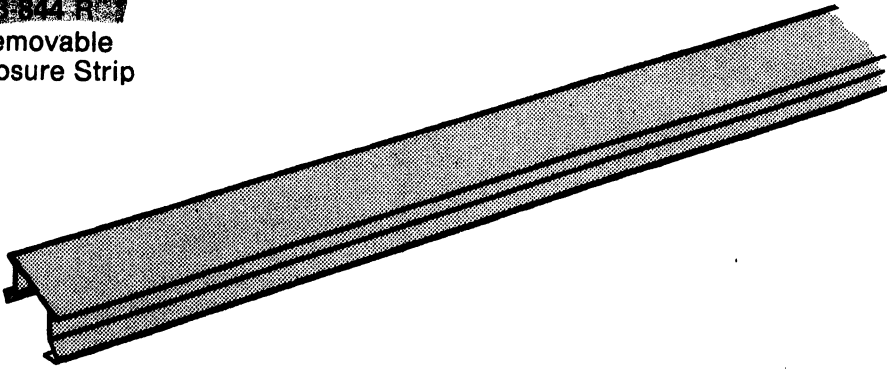

Designed as an added precaution to keep insert free of concrete. Closure strip fits all 1-5/8" wide strip inserts, regardless of depth.

20'-Lengths

C-475
Depth Adjustment in Field

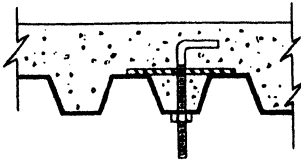

Threaded rod has GOLDGUARD finish.
Flat bar is not plated.

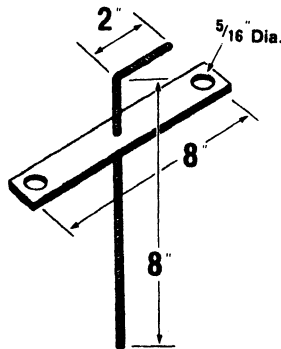

Prod. # and Rod Dia.	Wt./C lbs.	Design Load lbs.
C-475-3/8	75	610
C-475-1/2	97	1130
C-475-5/8	111	1610
C-475-3/4	142	2420
C-475-7/8	172	3360

Safety factor of 3 - in 3000 lb. hard rock concrete.

Beam Clamps, Pipe Clamps and Pipe Hangers — SECTION 5

Series 500/700/800



Materials

Most products are manufactured from hot rolled carbon steel bars or hot rolled strip steel. Pipe rollers are cast iron. Products which are copper plated carry the letter "T" in the prefix.

Design Loads

Where design loads are indicated, they provide for a safety factor of 5 in conformance with the "AMERICAN STANDARD CODE FOR PRESSURE PIPING".



Hanger Design

Pipe hangers are of advanced design and afford a new and better way for ordinary use.

Standard Dimensions

The following, except where noted, apply to all beam clamp fittings.

Hole Size	9/16" diameter
Material	1-5/8" wide
Material	1/4" thick



	PAGE		PAGE
•Pipe Straps	24	•Beam Clamps for Mounting	
•Pipe Clamps	28	Pipe and Conduit	37
•Cable Clamps	30	•Pipe Hangers	38
•Beam Clamps for		•Saddles, Shields and Rollers . . .	40
Mounting Channel	31		
•Beam Clamps for			
Hanging Rod	33		

SECTION 5 Beam Clamps, Pipe Clamps and Pipe Hangers — Series 500/700/800

Pipe Straps

700 Thin Wall Conduit Clamp

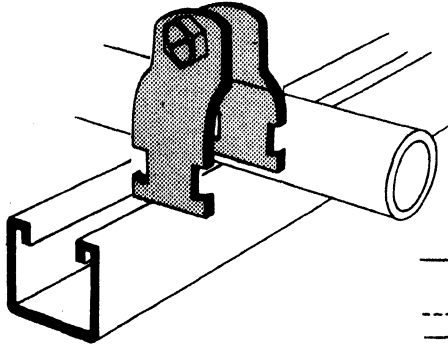

Design Loads

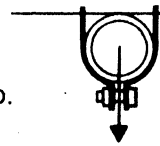

Machine screw and nut included.
Standard Finish - ELECTRO-GALVANIZED.
Also Fits 1-1/2" wide channel.

Prod. # And Size	Pipe O.D.	Material	Wt./C lbs.	Design Load lbs.
700-3/8	.557	16 ga.	12	400
700-1/2	.706	16 ga.	14	400
700-3/4	.922	16 ga.	13	400
700-1	1.163	14 ga.	16	600
700-1-1/4	1.508	14 ga.	19	600
700-1-1/2	1.738	14 ga.	20	600
700-2	2.195	14 ga.	22	600

701 OD Tubing Pipe Clamps

Machine screw and nut included.
Standard Finish - ELECTRO-GALVANIZED.

CT-701 Copper Plated OD Tubing Pipe Clamps

Machine screw and nut included.
See Price Sheet for Sizes Available.

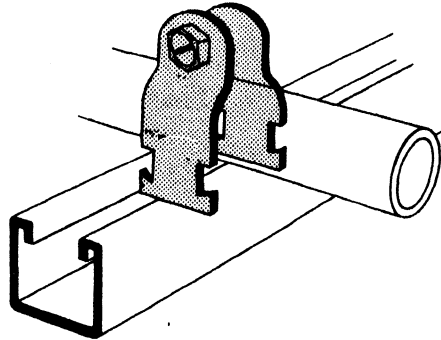

Design Loads

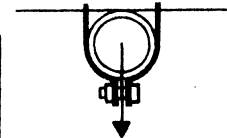

Prod. # And Size	Material	Wt./C lbs.	Design Load lbs.
701-1/4	16 ga.	8	400
701-3/8	16 ga.	8	400
701-1/2	16 ga.	9	400
701-5/8	16 ga.	10	400
701-3/4	16 ga.	11	400
701-7/8	16 ga.	12	400
701-1	14 ga.	12	600
701-1-1/8	14 ga.	12	600
701-1-1/4	14 ga.	13	600
701-1-3/8	14 ga.	14	600
701-1-1/2	14 ga.	14	600
701-1-5/8	14 ga.	15	600
701-1-3/4	14 ga.	28	600
701-1-7/8	14 ga.	29	600
701-2	14 ga.	31	600
701-2-1/8	14 ga.	32	600
701-2-1/4	14 ga.	33	600
701-2-3/8	14 ga.	34	600
701-2-1/2	12 ga.	35	800
701-2-5/8	12 ga.	37	800
701-2-3/4	12 ga.	38	800
701-2-7/8	12 ga.	40	800
701-3	12 ga.	41	800
701-3-1/8	12 ga.	43	800
701-3-1/4	12 ga.	45	800

Prod. # And Size	Material	Wt./C lbs.	Design Load lbs.
701-3-3/8	12 ga.	46	800
701-3-1/2	12 ga.	47	800
701-3-5/8	11 ga.	56	1000
701-3-3/4	11 ga.	58	1000
701-3-7/8	11 ga.	60	1000
701-4	11 ga.	62	1000
701-4-1/8	11 ga.	62	1000
701-4-1/4	11 ga.	64	1000
701-4-3/8	11 ga.	66	1000
701-4-1/2	11 ga.	67	1000
701-4-5/8	11 ga.	70	1000
701-4-3/4	11 ga.	72	1000
701-4-7/8	11 ga.	73	1000
701-5	11 ga.	74	1000
701-5-1/8	11 ga.	76	1000
701-5-1/4	11 ga.	77	1000
701-5-3/8	11 ga.	78	1000
701-5-1/2	11 ga.	79	1000
701-5-5/8	10 ga.	88	1000
701-5-3/4	10 ga.	90	1000
701-5-7/8	10 ga.	92	1000
701-6	10 ga.	94	1000

SEE PRICE SHEET
FOR LARGER SIZES

Beam Clamps, Pipe Clamps and Pipe Hangers — SECTION 5

Series 500/700/800

Pipe Straps

702

Pipe and Rigid or IMC Conduit Clamp

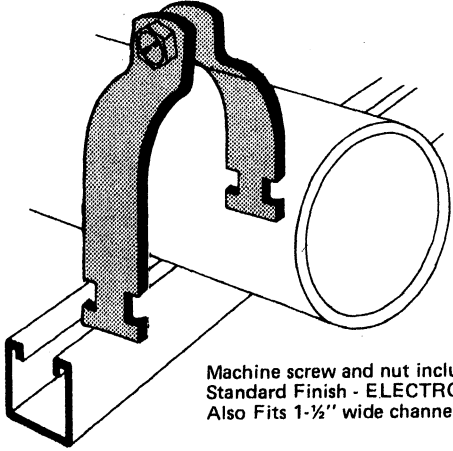

Machine screw and nut included.
Standard Finish - ELECTRO-GALVANIZED.
Also Fits 1-1/2" wide channel.

Design Loads

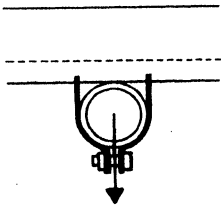

Prod. # And Size	Pipe O.D.	Material	Wt./C lbs.	Design Load lbs.
702-3/8	.675	14 ga.	14	400
702-1/2	.840	14 ga.	13	400
702-3/4	1.050	14 ga.	15	600
702-1	1.315	14 ga.	17	600
702-1-1/4	1.660	14 ga.	19	600
702-1-1/2	1.900	14 ga.	28	600
702-2	2.375	14 ga.	31	600
702-2-1/2	2.875	14 ga.	36	800
702-3	3.500	12 ga.	42	800
702-3-1/2	4.000	12 ga.	56	1000
702-4	4.500	12 ga.	64	1000
702-5	5.562	12 ga.	76	1000
702-6	6.625	12 ga.	89	1000
702-8	8.625	12 ga.	114	1000

See Page 50 for Standard Packing.

703

Universal Clamp

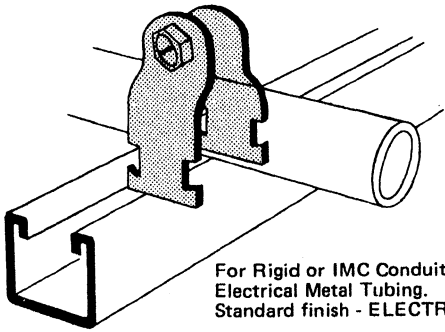

For Rigid or IMC Conduit, Pipe, &
Electrical Metal Tubing.
Standard finish - ELECTRO-GALVANIZED

Prod. # and Size	Pipe O.D.	Material	Wt./C lbs.	Design Load lbs.
703-1/2	.706	14 ga.	15	400
703-3/4	.922	14 ga.	16	400
703-1	1.163	14 ga.	18	600
703-1-1/4	1.508	14 ga.	20	600
703-1-1/2	1.738	14 ga.	29	800
703-2	2.195	14 ga.	34	800
*703-2-1/2	2.875	14 ga.	42	800
*703-3	3.500	12 ga.	48	800
*703-3-1/2	4.000	12 ga.	52	1000
*703-4	4.500	12 ga.	59	1000

*Also fits 1-1/2" wide channel.

703-5
703-6

SECTION 5 Beam Clamps, Pipe Clamps and Pipe Hangers — Series 500/700/800

Pipe Straps

A-716 Cush-A-Clamp™

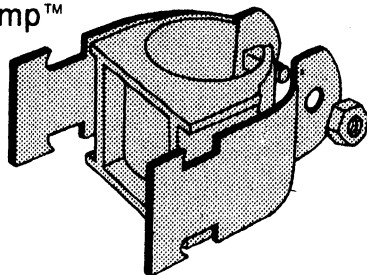

Assembly consisting of ELECTRO-GALVANIZED finish steel clamp with controlled squeeze shoulder bolt with locknut and modified thermoplastic elastomer cushion.

Secure Pipes, tubes and hoses for fluid conductors with the Superstrut Cush-A-Clamp system. Installation is easy and requires no more time than a simple pipe clamp installation. The cushion absorbs the shocks and associated vibrations from fluid surges in tubes, pipes and hoses. It can handle temperatures from 300 F down to -30 F. Cushions are available in sizes from 1/4" to 4 1/2".

Assembly Part. #	Includes Cushion #	Wt./C lbs.
A-716-1/4	4	10
A-716-3/8	6	11
A-716-1/2	8	13
A-716-5/8	10	14
A-716-3/4	12	14
A-716-7/8	14	15
A-716-1	16	17
A-716-1-1/8	18	18
A-716-1-1/4	20	18
A-716-1-3/8	22	20
A-716-1-1/2	24	33
A-716-1-5/8	26	35
A-716-1-3/4	28	37
A-716-1-7/8	30	39
A-716-2	32	41
A-716-2-1/8	34	46
A-716-2-3/8	38	47
A-716-2-5/8	42	51
A-716-3-1/8	50	60
A-716-4-1/8	66	94

C-715 Isolator (Pipe)

Order by Prod. # and size.

C-716 Isolator (Copper Tube)

Order by Prod. # and size.

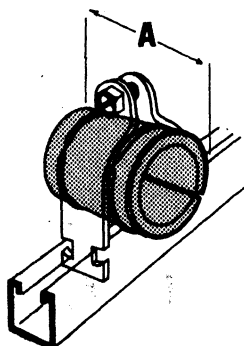

FEATURES

Designed for use with: Superstrut Channel and Pipe straps and Superstrut C-711 Hangers and may also be used with all standard flatbar or malleable iron hangers.

MATERIALS

Manufactured from one piece steel shell with reinforcing ribs for stiffening and alignment. Padding is of processed non-conducting hair-felt and is cemented to the metal. Design of ribs creates a hinge so isolator may be opened and closed to install.

APPLICATION

To provide a means to effectively isolate piping from its supports to prevent the transmission of sound and vibration.

C-715 FOR STANDARD PIPE

Size	Nominal Pipe Size	Hanger, C-711 Or Pipe Strap, 702	Width A	Wt./C lbs.
1/2	1/2	3/4	2 3/8	5.10
3/4	3/4	1	2 3/8	6.40
1	1	1 1/4	2 3/8	7.30
1-1/4	1 1/4	1 1/2	2 3/8	7.70
1-1/2	1 1/2	2	2 3/8	9.50
2	2	2 1/2	2 3/8	15.40
2-1/2	2 1/2	3	2 3/8	17.20
3	3	3 1/2	2 3/8	21.50
3-1/2	3 1/2	4	4 1/4	37.10
4	4	5	4 1/4	43.10

C-716 FOR COPPER TUBING

Size	Nominal Tube Size	Hanger, C-711 Or Pipe Strap, 702	Width A	Wt./C lbs.
3/8	3/8	1/2	2 3/8	5.0
1/2	1/2	3/4	2 3/8	5.30
3/4	3/4	3/4	2 3/8	5.10
1	1	1	2 3/8	6.40
1-1/4	1 1/4	1 1/4	2 3/8	7.80
1-1/2	1 1/2	1 1/2	2 3/8	8.20
2	2	2 1/2	2 3/8	15.40
2-1/2	2 1/2	3	2 3/8	17.20
3	3	3 1/2	2 3/8	21.50
3-1/2	3 1/2	4	4 1/4	43.10
4	4	5	4 1/4	57.80

Sizes 3-1/2" and 4" have 4 reinforcing ribs.

Beam Clamps, Pipe Clamps and Pipe Hangers — SECTION 5

Series 500/700/800

Pipe Straps

S7181 Cush-A-Strip™

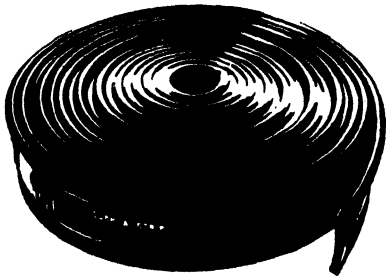

1/4" markings for fast measuring and cutting.

Prevent metal to metal contact with the Superstrut Cush-A-Strip. It aids in sound insulation, shock absorption and protects against corrosion, distortion and abrasion. Cush-A-Strip is designed for optimal use between -30°F to 300°F. Cush-A-Strip combined with the Superstrut 701 pipe strap can handle clamping assignments from 1/4" to 6".

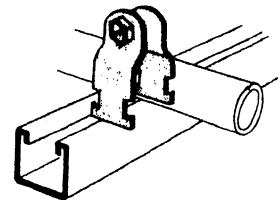

Order 701 clamp separately.

For use with 701 O.D. tubing and pipe clamp. To determine 701 clamp size add 1/4" to O.D. tube size to allow for the Cush-A-Strip.

C-708-U Short Strap for Channel Mounting Carbon Steel

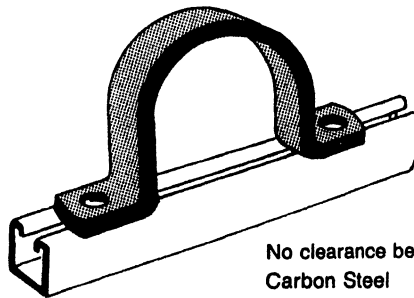

No clearance between pipe and channel.
Carbon Steel

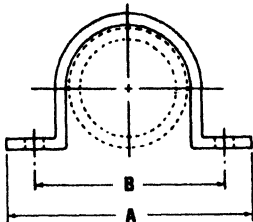

DIMENSIONS (Inches) - WEIGHTS - LOADS

Pipe Size	A	B	Hole Size	Stock Size	Wt./C lbs.	Design Load lbs.
1/2	2 3/8	2	9/32	1/8 x 1 1/8	23	400
3/4	3 1/8	2 3/8	9/32	1/8 x 1 1/8	26	400
1	3 3/8	2 1/2	9/32	1/8 x 1 1/8	31	400
1-1/4	3 11/16	2 13/16	9/32	1/8 x 1 1/8	35	400
1-1/2	3 15/16	3 1/8	9/32	1/8 x 1 1/8	39	400
2	5 1/8	4 1/8	7/16	1/4 x 1 1/8	94	400
2-1/2	6 3/16	4 9/16	7/16	1/4 x 1 1/8	114	610
3	6 13/16	5 3/16	7/16	1/4 x 1 1/8	133	610
3-1/2	7 5/16	5 11/16	7/16	1/4 x 1 1/8	152	610
4	7 13/16	6 3/16	7/16	1/4 x 1 1/8	176	725
5	8 3/8	7 1/4	7/16	1/4 x 1 1/8	198	725
6	9 15/16	8 5/16	7/16	1/4 x 1 1/8	246	725

SECTION 5 Beam Clamps, Pipe Clamps and Pipe Hangers — Series 500/700/800

Pipe Clamps

C-720 HDGAF OR E.G.M.V. OR BLACK
Riser Clamp

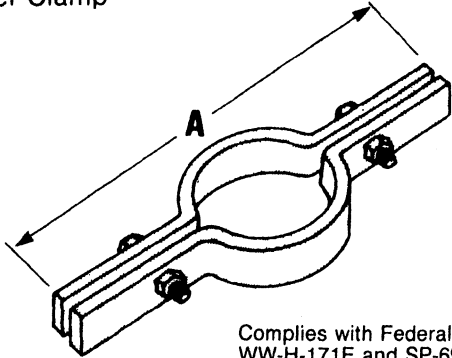

Complies with Federal Spec. WW-H-171E and SP-69, Type 8.

DIMENSIONS (inches) - WEIGHTS - LOADS

Pipe Size	A	Stock Size	Bolt Size	Wt./C lbs.	Design Load lbs.
1/2	9 1/4	3/16 x 1 1/4	3/8 x 1 1/2	138	255
3/4	9 1/4	3/16 x 1 1/4	3/8 x 1 1/2	138	255
1	9 9/16	3/16 x 1 1/4	3/8 x 1 1/2	140	255
1-1/4	9 11/16	3/16 x 1 1/4	3/8 x 1 1/2	150	255
1-1/2	10 3/8	3/16 x 1 1/4	3/8 x 1 1/2	155	255
2	10 3/4	3/16 x 1 1/4	3/8 x 1 1/2	160	255
2-1/2	11 3/8	1/4 x 1 1/4	3/8 x 1 1/2	225	390
3	12	1/4 x 1 1/4	3/8 x 1 1/2	250	530
3-1/2	13	1/4 x 1 1/4	3/8 x 1 1/2	265	670
4	13 1/2	1/4 x 1 1/4	1/2 x 1 1/2	330	810
5	14 1/2	1/4 x 1 1/2	1/2 x 1 1/2	365	1160
6	15 1/8	1/4 x 2	1/2 x 1 1/2	410	1570
8	18 1/2	3/8 x 2	5/8 x 2 1/2	695	2500
10	20 3/4	3/8 x 2	5/8 x 2 1/2	1150	2500
12	22 3/4	1/2 x 2	5/8 x 2 1/2	1800	2700

Note: Load rating based on cast iron soil pipe. Load rating for other pipe may vary depending on coefficient of friction of pipe surface.

C-725 HDGAF OR E.G.M.V. OR BLACK
Medium Pipe Clamp
Carbon steel

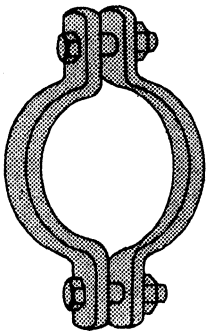

DIMENSIONS (Inches) - WEIGHTS - LOADS

Pipe Size	Stock Size	Bolt Size	A	B	C	Wt./C lbs.	Design Load lbs.* for Service Temp.	
							650°F	750°F
1/2	1/8 x 1	5/16 x 1	2 13/16	3/8	2 1/16	29	500	445
3/4	1/8 x 1	5/16 x 1	3	3/8	2 1/4	33	500	445
1	1/8 x 1	5/16 x 1	3 9/16	3/8	2 1/2	35	500	445
1-1/4	1/8 x 1	5/16 x 1	4 3/16	3/8	3 1/8	37	500	445
1-1/2	1/8 x 1	5/16 x 1	4 1/4	3/8	3	40	800	715
2	1/4 x 1	3/8 x 1-1/2	5	3/8	3 3/4	81	1040	930
2-1/2	1/4 x 1	1/2 x 1-1/2	6	1/2	5	114	1040	930
3	1/4 x 1	1/2 x 1-1/2	6 3/4	1/2	5 3/4	130	1040	930
3-1/2	1/4 x 1	1/2 x 1-3/4	7 1/4	1/2	6 1/4	150	1040	930
4	1/4 x 1-1/4	5/8 x 1-3/4	7 3/4	5/8	6 5/8	204	1040	930
5	1/4 x 1-1/4	5/8 x 1-3/4	8 7/8	5/8	7 3/4	250	1040	930
6	3/8 x 1-1/2	3/4 x 2-1/2	11 1/4	3/4	9 3/4	510	1615	1440
8	3/8 x 1-1/2	3/4 x 2-1/2	13 1/8	7/8	11 5/8	590	1615	1440
10	1/2 x 2	7/8 x 3	16 1/2	7/8	14 1/2	1362	2490	2220
12	1/2 x 2	7/8 x 3	18 1/2	7/8	16 1/2	1518	2490	2220

* Based on the allowable stresses shown in the ANSI Code for Pressure Piping.

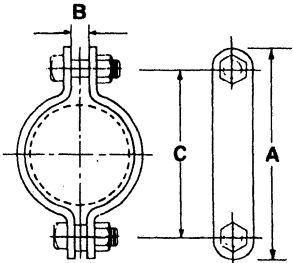

For suspension of pipe lines where little or no insulation is required.

Complies with Federal Spec. WW-H-171E and SP-69, Type 4.

Order by Prod. #, pipe size.

SECTION 5 Beam Clamps, Pipe Clamps and Pipe Hangers — Series 500/700/800

Cable Clamps

AB-840P thru AB-873P Porcelain Cable Clamps

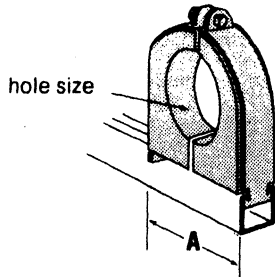

Furnished with ELECTRO-GALVANIZED finished steel clamp and bronze hardware.
Also fits 1-1/2" wide channel.

Prod. #	Hole Size	A	Wt./C lbs.
AB-840P	3/8	1 9/16	50
AB-841P	1/2	1 9/16	50
AB-842P	5/8	1 9/16	50
AB-843P	3/4	2 5/32	91
AB-844P	7/8	2 5/32	90
AB-845P	1	2 5/32	85
AB-846P	1 1/8	2 5/32	82
AB-847P	1 1/4	2 5/8	114
AB-848P	1 3/8	2 5/8	110
AB-849P	1 1/2	2 5/8	105
AB-850P	1 5/8	2 5/8	102
AB-851P	1 3/4	3 3/4	220
AB-852P	1 7/8	3 3/4	214
AB-853P	2	3 3/4	205
AB-854P	2 1/8	3 3/4	200
AB-855P	2 1/4	4 1/4	260
AB-856P	2 3/8	4 1/4	250
AB-857P	2 1/2	4 1/4	243
AB-858P	2 5/8	4 1/4	240
AB-859P	2 3/4	4 3/4	250
AB-860P	2 7/8	4 3/4	240
AB-861P	3	4 3/4	230
AB-862P	3 1/8	4 3/4	220
AB-863P	3 1/4	5 13/16	340
AB-864P	3 3/8	5 13/16	330
AB-865P	3 1/2	5 13/16	318
AB-866P	3 5/8	5 13/16	387
AB-867P	3 3/4	6 7/8	565
AB-868P	3 7/8	6 7/8	550
AB-869P	4	6 7/8	535
AB-870P	4 1/8	6 7/8	520
AB-871P	4 1/4	6 7/8	490
AB-872P	4 3/8	6 7/8	475
AB-873P	4 1/2	6 7/8	460

AB-880

3" Porcelain Saddle

AB-881

4" Porcelain Saddle

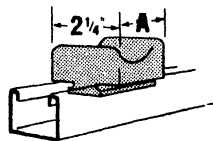

Prod.#	A	Max. Cable Diam.	Wt./C lbs.
AB-880	3	3	73
AB-881	4	4-1/2	104

Beam Clamps, Pipe Clamps and Pipe Hangers — SECTION 5

Series 500/700/800

Cable Clamps

U-861 Maple Cable Clamp

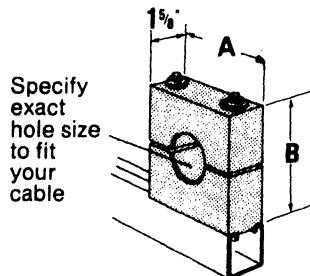

Prod. #	Range of Hole Sizes Specify Cable O.D.
U-861-1	0 to 1
U-861-2	1 to 1-1/2
U-861-3	1-1/2 to 2
U-861-4	2 to 2-1/2
U-861-5	2-1/2 to 3
U-861-6	3 to 3-1/2
U-861-7	3-1/2 to 4
U-861-8	Over 4

A	B	Wt./C lbs.
3-1/2	3-1/2	84
4	4	102
4-1/2	4-1/2	121
5-1/2	5-1/2	165
6	6	189
6-1/2	6-1/2	215
7	7	243
—	—	—

MATERIAL: Paraffin Impregnated Maple Hardwood 3/8" Studs, Square Nuts and Washers included

Beam Clamps for Mounting Channel

U-501, U-502 ONLY PUNTS

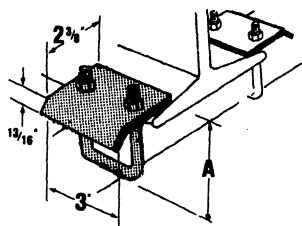

Furnished complete
Design Load 1275 lbs.

Prod. #	For Channel	A	Wt./C lbs.
U-501	A-1200 A-1400	3 ³ / ₁₆	90
	B-1200 B-1400		
	C-1200 B-1402		
U-502	A-1202 A-1402	4 ¹³ / ₁₆	100
	C-1202		

U-504

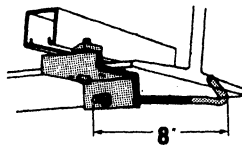

wt./C 140 lbs.

U-505

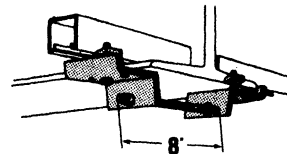

wt./C 270 lbs.

SECTION 5 Beam Clamps, Pipe Clamps and Pipe Hangers — Series 500/700/800

Beam Clamps for Mounting Channel

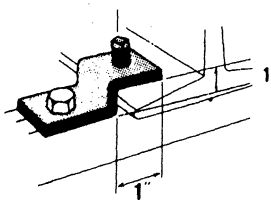
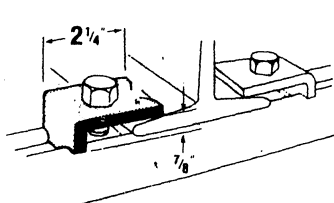
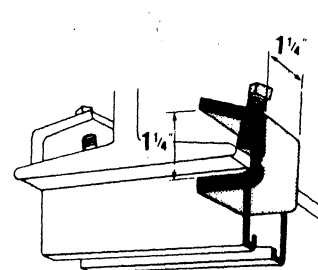
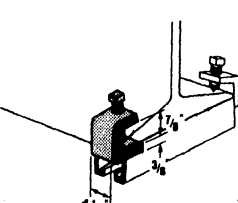
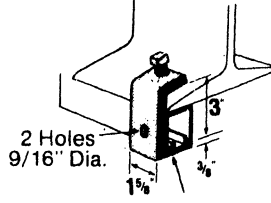
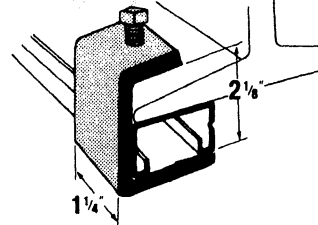
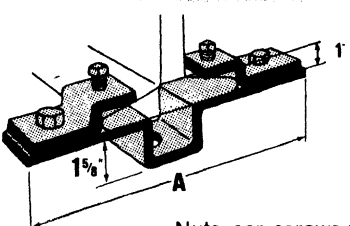
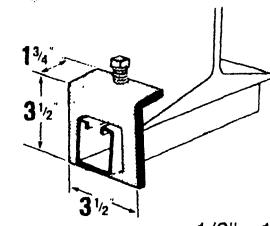
<p>U-510</p>  <p>1/2" x 1-1/2" set screw included. Order separately one 1/2" x 1-1/2" hex head cap screw and 1/2" channel nut.</p> <table border="1"> <thead> <tr> <th>Design Load lbs.</th> <th>Channel</th> </tr> </thead> <tbody> <tr> <td>600</td> <td>A-1200</td> </tr> <tr> <td>500</td> <td>A-1400</td> </tr> </tbody> </table> <p>wt./C 75 lbs.</p>	Design Load lbs.	Channel	600	A-1200	500	A-1400	<p>512</p>  <p>Order separately one 1/2" x 1-1/2" hex head cap screw and 1/2" channel nut.</p> <table border="1"> <thead> <tr> <th>Design Load lbs.</th> <th>Channel</th> </tr> </thead> <tbody> <tr> <td>600</td> <td>A-1200</td> </tr> <tr> <td>500</td> <td>A-1400</td> </tr> </tbody> </table> <p>wt./C 26 lbs.</p>	Design Load lbs.	Channel	600	A-1200	500	A-1400	<p>U-514</p>  <p>3/8" x 1-1/2" set screw included.</p> <p>Design Load 450 lbs./per pair wt./C 40 lbs.</p>																
Design Load lbs.	Channel																													
600	A-1200																													
500	A-1400																													
Design Load lbs.	Channel																													
600	A-1200																													
500	A-1400																													
<p>U-514-A</p>  <p>1/2" x 1-1/2" set screw included.</p> <p>Design Load 1000 lbs./per pair wt./C 59 lbs.</p>	<p>U-515</p>  <p>2 Holes 9/16" Dia.</p> <p>For all "A" series channel. 1/2" x 1-1/2" set screw included.</p> <p>Design Load 500 lbs. wt./C 95 lbs.</p>	<p>U-515-B</p>  <p>For all "B" series channel. 1/2" x 1-1/2" set screw included.</p> <p>Design load 500 lbs. wt./C 91 lbs.</p>																												
<p>U-520, U-521, & U-522</p>  <p>Nuts, cap screws and set screws included.</p> <table border="1"> <thead> <tr> <th>Prod. #</th> <th>Flange Width</th> <th>A</th> <th>Design Load lbs.</th> <th>Wt./C lbs.</th> </tr> </thead> <tbody> <tr> <td>U-520</td> <td>2 3/4" - 4 1/2"</td> <td>8 3/4"</td> <td>1200</td> <td>328</td> </tr> <tr> <td>U-521</td> <td>3 3/4" - 5 1/4"</td> <td>10"</td> <td>800</td> <td>343</td> </tr> <tr> <td>U-522</td> <td>5 5/8" - 7 1/8"</td> <td>11 1/8"</td> <td>560</td> <td>353</td> </tr> </tbody> </table> <p>When ordering specify flange width.</p>	Prod. #	Flange Width	A	Design Load lbs.	Wt./C lbs.	U-520	2 3/4" - 4 1/2"	8 3/4"	1200	328	U-521	3 3/4" - 5 1/4"	10"	800	343	U-522	5 5/8" - 7 1/8"	11 1/8"	560	353		<p>A-597</p>  <p>1/2" x 1-1/2" set screw included.</p> <table border="1"> <thead> <tr> <th>Prod. #</th> <th>Design Load lbs./ea.</th> <th>Channel Series</th> <th>Wt./C lbs.</th> </tr> </thead> <tbody> <tr> <td>A-597</td> <td>480</td> <td>A</td> <td>108</td> </tr> </tbody> </table>	Prod. #	Design Load lbs./ea.	Channel Series	Wt./C lbs.	A-597	480	A	108
Prod. #	Flange Width	A	Design Load lbs.	Wt./C lbs.																										
U-520	2 3/4" - 4 1/2"	8 3/4"	1200	328																										
U-521	3 3/4" - 5 1/4"	10"	800	343																										
U-522	5 5/8" - 7 1/8"	11 1/8"	560	353																										
Prod. #	Design Load lbs./ea.	Channel Series	Wt./C lbs.																											
A-597	480	A	108																											

Beam Clamps, Pipe Clamps and Pipe Hangers — SECTION 5

Series 500/700/800

Beam Clamps for Hanging Rod

540
Side Beam Hanger Clip

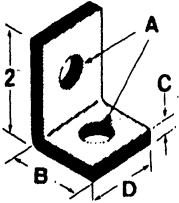

Prod. #	A	B	C	D	Wt./C lbs.
540-3/8	7/16	1-7/8	1/4	1-5/8	58
540-1/2	9/16	1-7/8	1/4	1-5/8	36
540-5/8	11/16	2-1/2	3/8	2	84
540-3/4	13/16	2-1/2	3/8	2	113
540-7/8	15/16	3-1/8	1/2	2	106

542
Side Beam Hanger Clip

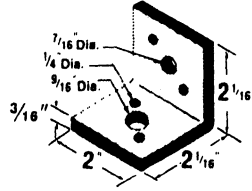

For 3/8" and 1/2" rods.

Rod Size	Design Load lbs.
3/8	610
1/2	1000

wt./C 45 lbs.

U-550
Beam Clamp

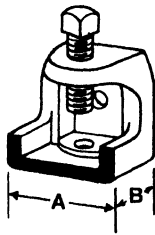

Superstrut Cat. No. and Size	Tapped Holes	Base Dim. inches		Jaw Opening	Wt./C lbs.	Design Load lbs.
		A	B			
U-550-1/4	1/4-20	1	1 1/4	15/16	23	270
U-550-3/8	3/8-16	2	2	1	92	780
U-550-1/2	1/2-13	2 5/8	2 1/2	1	164	780

U-560
Heavy Duty Beam Clamp

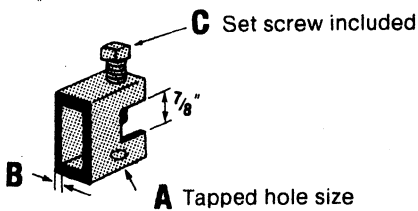

DIMENSIONS (Inches) - WEIGHTS - LOADS

Prod. #	A	B	C	Wt./C lbs.	Design Load lbs.
U-560-1/4	1/4	1/8	3/8 x 1 1/2	67	650
U-560-3/8	3/8	1/8	3/8 x 1 1/2	67	650
U-560-1/2	1/2	1/4	1/2 x 1 1/2	130	1600
U-560-5/8	5/8	1/4	1/2 x 1 1/2	130	1600

SECTION 5 Beam Clamps, Pipe Clamps and Pipe Hangers — Series 500/700/800

Beam Clamps for Hanging Rod

U-564

Heavy Duty Beam Clamp

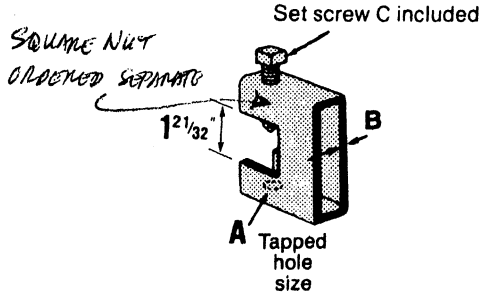

Prod. #	A	B	C	Wt./C lbs.	Design Load lbs.
U-564-3/8	3/8	1/8	3/8 x 2 3/4	109	800
U-564-1/2	1/2	1/4	1/2 x 2 3/4	201	1900
U-564-5/8	5/8	1/4	1/2 x 2 3/4	201	1900

U-562

Beam Clamp

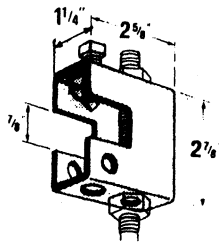

1/2" set screw included.

Rod Size	Wt./C lbs.	Design Load lbs.
1/2	80	300

Beam Clamp Optional Use

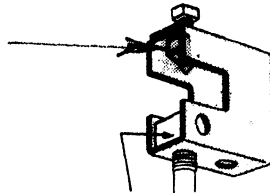

Square nut order separately.
1/2" set screw included.

Rod Size	Wt./C lbs.	Design Load lbs.
1/2	80	500

For 20° swivel application
use ES-145-1/2 nut.

US-562

Beam Clamp with Swing Hanger

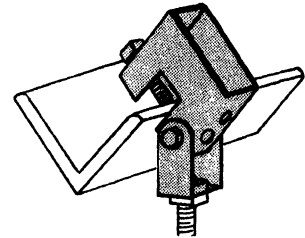

1/2" set screw included.

Rod Size	Wt./C lbs.	Design Load lbs.
1/2	113	500

U-563

Beam Clamp

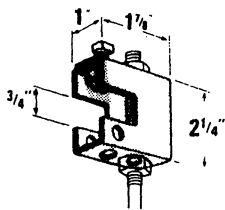

3/8" set screw included.

Rod Size	Wt./C lbs.	Design Load lbs.
3/8	33	150

Beam Clamp Optional Use

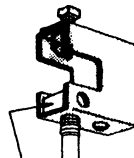

Square nut order separately.
3/8" set screw included.

Rod Size	Wt./C lbs.	Design Load lbs.
3/8	33	250

US-563

Beam Clamp with Swing Hanger

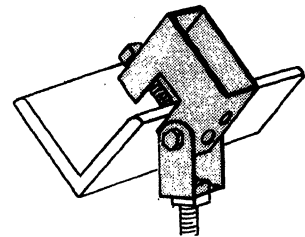

3/8" set screw included.

Rod Size	Wt./C lbs.	Design Load lbs.
3/8	50	250

Beam Clamps, Pipe Clamps and Pipe Hangers — SECTION 5

Series 500/700/800

Beam Clamps for Hanging Rod

U-568
Beam Clamp Safety Strap

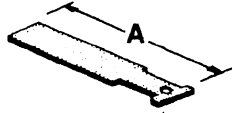

For U-563 beam clamp.

Prod. #	Beam Flange Width	A
U-568-1	6	8
U-568-2	9	11

16 ga. material

U-568
Beam Clamp Safety Strap

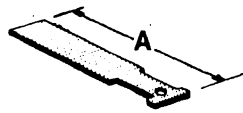

For U-562 beam clamp.

Prod. #	Beam Flange Width	A
U-568-3	6	9
U-568-4	9	12
U-568-5	12	15

16 ga. material

U-568
Beam Clamp Safety Strap

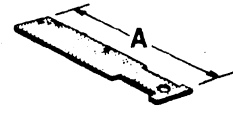

For U-560 and U-564 beam clamp.

Prod. #	Beam Flange Width	A
U-568-6	6	9
U-568-7	9	12
U-568-8	12	15

16 ga. material

U-569
Beam Clamp
With Safety Rod

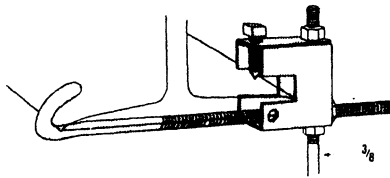

Maximum flange width 5". Wider than 5" flange, specify flange width on special order.

Design Load 250 lbs.
wt./C 150 lbs.

A-570
Beam Clamp with Safety Rod

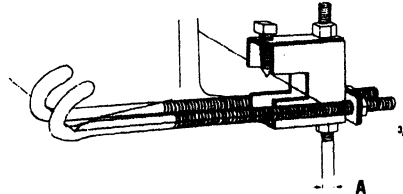

Flange width 4" min. — 8" max.

Prod. #	A Size	Wt./C lbs.	Design Load lbs. 650°F
A-570		220	300

For use with 3/8" hanger rod see U-569
For larger flanges, special order and specify flange width.

U-576
Hanger Clevis

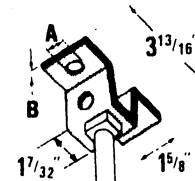

Rod up to 1/2"

Mounting holes 7/16 diam.
For use with wood beam.

Prod. #	Hole A	Matl. Thk. B	Wt./C lbs.
U-576-3/8	7/16	3/16	27
U-576-1/2	9/16	3/16	27

U-577
Clevis & Swing Connector

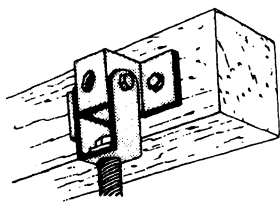

For use with wood beam.

Rod Size	Wt./C lbs.
1/2	69

U-579
Ceiling Flange

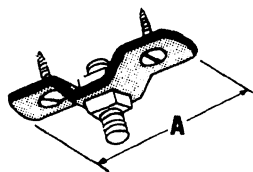

Nuts and wood screws not included.
Mounting holes 13/32"

Prod. #	A	Wt./C lbs.
U-579-1/2	3 1/2	30
	4 1/4	50

SECTION 5 Beam Clamps, Pipe Clamps and Pipe Hangers — Series 500/700/800

Beam Clamps for Hanging Rod

C-775-L
Clamp with Lock Nut

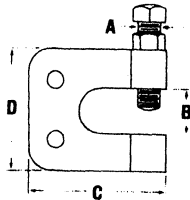
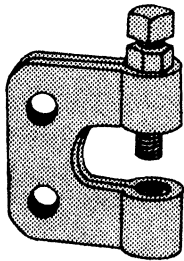

DIMENSIONS (inches) - WEIGHTS - LOADS

Rod Size	A	B	C	D	Wt./C lbs.	Design Load lbs.
					C-775-L	
3/8	3/8	3/8	2 1/4	2 1/4	35	330
1/2	1/2	3/4	2 1/4	2 1/4	41	380
5/8	5/8	3/4	2 5/16	2 1/4	67	750
3/4	3/4	3/4	2 5/16	2 1/4	71	630
7/8	7/8	3/4	2 5/16	2 1/4	71	630

M-775-L
Clamp with Lock Nut

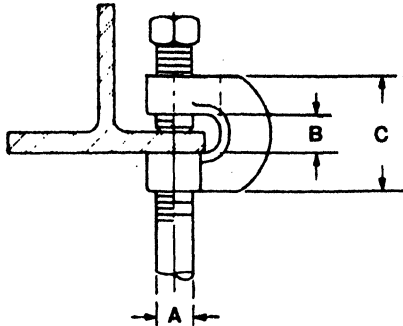
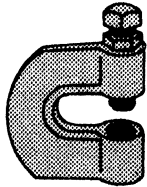

DIMENSIONS (inches) - WEIGHTS - LOADS

Rod Size A	B	C	Wt./C lbs.	Design Load lbs.
			M-775L	
3/8	3/4	1-1/2	35	510
1/2	3/4	1-3/4	49	535
5/8	3/4	2	62	550
3/4	3/4	2	87	630

M-777
Junior Top Beam C-Clamp
Malleable Iron.

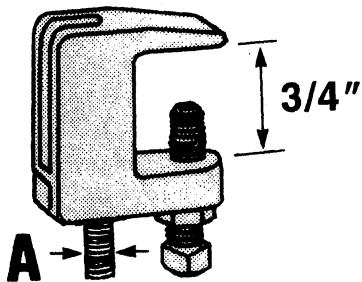

DIMENSIONS (inches) - WEIGHTS - LOADS

Rod Size A	Wt./C lbs.	Design Load lbs.
3/8	28	350
1/2	37	470
5/8	45	470
3/4	67	470
7/8	66	470

Provides clamping under roof installations with bar joist construction. Max. joist thickness 5/8".
Order by Prod. #, rod size.

Beam Clamps, Pipe Clamps and Pipe Hangers — SECTION 5

Series 500/700/800

Beam Clamps for Hanging Rod

M-778

Top Beam C-Clamp
Malleable iron

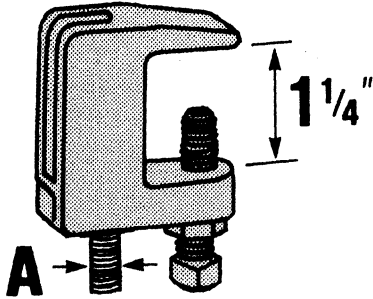

DIMENSIONS (inches) - WEIGHTS - LOADS

Rod Size A	Wt./C lbs.	Design Load lbs.
3/8	44	440
1/2	42	710

Provides clamping under roof installations with bar joist type construction.
Order by Prod. #, rod size.

C-781

Steel Washer Plate
Carbon steel

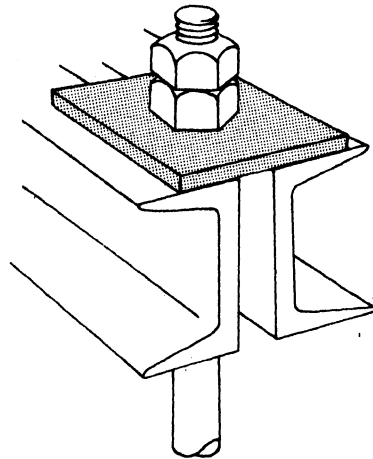

A heavy duty square washer used with channels or angles for supporting pipe with rods or U-bolts.
Order by Prod. #, rod size.

DIMENSIONS (inches) - WEIGHTS

Rod Size	Size of Stock	Hole Dia.	Wt./C lbs.
3/8	3 x 3 x 1/4	1/2	62
1/2	3 x 3 x 1/4	5/8	62
5/8	3 x 3 x 3/8	3/4	91
3/4	4 x 4 x 3/8	7/8	164

SECTION 5 Beam Clamps, Pipe Clamps and Pipe Hangers — Series 500/700/800

Beam Clamps for Mounting Pipe and Conduit

U-571, U-572 Conduit Clamp

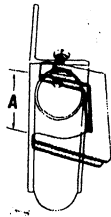

For attaching 1/2" thru 1-1/2" conduit to beam, channel, angle or column. Secures conduit to the support parallel or at right angles to it.

5/16 set screw
12 ga. material

Prod. #	Conduit Size	Max. Thickness	Flange Dim. A	Wt./C lbs.
U-571	1/2	1	1-3/4	36
U-571	3/4	3/4	1-3/4	36
U-571	1	1/2	1-3/4	36
U-572	3/4	1-1/2	2-1/2	59
U-572	1	1-1/4	2-1/2	59
U-572	1-1/4	1	2-1/2	59
U-572	1-1/2	5/8	2-1/2	59

wt./C 38 lbs.

U-597

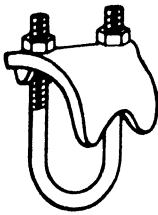

For mounting pipes or conduit at right angles to the beam.

Superstrut Cat. No. & Sizes	Dimensions in inches		Wt. in lbs./C
	O.D. of Conduit or Pipe	Nom. Conduit or Pipe Size	
U-597-1/2	0.840	1/2	36
U-597-3/4	1.050	3/4	41
U-597-1	1.315	1	42
U-597-1 1/4	1.660	1 1/4	50
U-597-1 1/2	1.900	1 1/2	57
U-597-2	2.375	2	78
U-597-2 1/2	2.875	2 1/2	109
U-597-3	3.500	3	118
U-597-3 1/2	4.000	3 1/2	134
U-597-4	4.500	4	144

U-598

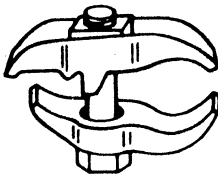

For mounting pipes or conduit parallel to the beam.

Superstrut Cat. No. & Sizes	Dimensions in inches		Wt. in lbs./C
	O.D. of Conduit or Pipe	Nom. Conduit or Pipe Size	
U-598-1/2	0.840	1/2	51
U-598-3/4	1.050	3/4	54
U-598-1	1.315	1	63
U-598-1 1/4	1.660	1 1/4	80
U-598-1 1/2	1.900	1 1/2	90
U-598-2	2.375	2	115
U-598-2 1/2	2.875	2 1/2	148
U-598-3	3.500	3	178
U-598-3 1/2	4.000	3 1/2	209
U-598-4	4.500	4	224

U-599

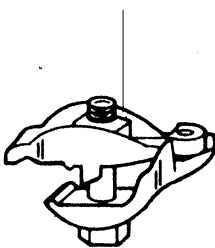

For mounting pipes or conduit vertically cross beam edge.

Superstrut Cat. No. & Sizes	Dimensions in inches		Wt. in lbs./C
	O.D. of Conduit or Pipe	Nom. Conduit or Pipe Size	
U-599-1/2	0.840	1/2	68
U-599-3/4	1.050	3/4	75
U-599-1	1.315	1	85
U-599-1 1/4	1.660	1 1/4	98
U-599-1 1/2	1.900	1 1/2	105
U-599-2	2.375	2	141
U-599-2 1/2	2.875	2 1/2	188
U-599-3	3.500	3	232

Beam Clamps, Pipe Clamps and Pipe Hangers — SECTION 5

Series 500/700/800

Pipe Hangers

C-710

Adjustable Clevis Hanger

Complies with Federal Spec. WW-H-171E and SP-69, Type 1.

Order by Prod. # and pipe size.

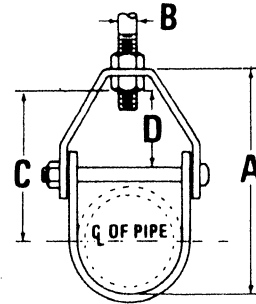
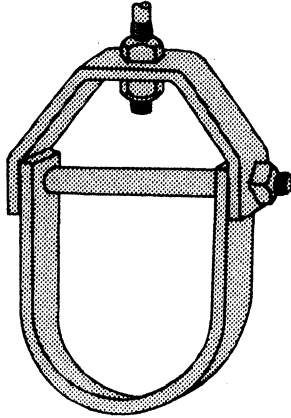

DIMENSIONS (inches) - WEIGHTS - LOADS

Pipe Size	A	B	C	D	Bolt Size	Top Stock	Bottom Stock	Wt./C lbs.	Design Load lbs.
1/2	27/8	3/8	13/16	1	1/4 x 2	1/8 x 1	1/8 x 1	32	610
3/4	31/16	3/8	17/8	1	1/4 x 2	1/8 x 1	1/8 x 1	36	610
1	33/8	3/8	21/16	1	1/4 x 2-1/4	1/8 x 1	1/8 x 1	40	610
1-1/4	33/4	3/8	21/4	1	1/4 x 2-1/4	1/8 x 1	1/8 x 1	44	610
1-1/2	41/16	3/8	23/8	1	1/4 x 2-3/4	1/8 x 1	1/8 x 1	48	610
2	41/2	3/8	23/4	1	1/4 x 3-1/4	1/8 x 1	1/8 x 1	55	610
2-1/2	51/2	1/2	31/4	1	3/8 x 4-1/2	3/16 x 1-1/4	3/16 x 1-1/4	118	1130
3	61/8	1/2	31/2	1 1/4	3/8 x 5-1/4	3/16 x 1-1/4	3/16 x 1-1/4	130	1130
3-1/2	63/4	1/2	33/4	1 1/4	3/8 x 5-3/4	3/16 x 1-1/4	3/16 x 1-1/4	160	1130
4	75/8	5/8	41/4	1 1/2	3/8 x 6-1/4	1/4 x 1-1/4	3/16 x 1-1/4	175	1430
5	87/8	5/8	51/4	1 1/2	1/2 x 7-1/2	1/4 x 1	3/16 x 1-1/4	230	1430
6	10	3/4	51/2	1 1/2	1/2 x 8-1/2	1/4 x 1-1/2	3/16 x 1-1/2	320	1940
8	123/4	7/8	71/8	2	5/8 x 11	1/4 x 1-1/2	3/16 x 1-1/2	450	1940
10	171/8	7/8	111/8	3 1/4	3/4 x 13-1/2	3/8 x 1-3/4	1/4 x 1-3/4	1060	3600
12	185/8	7/8	115/8	3 1/2	3/4 x 15-3/4	3/8 x 2	1/4 x 2	1284	3800

3.63
 3.37
 3.63
 4.04
 4.65
 9.94
 10.96
 13.49
 14.72

SECTION 5 Beam Clamps, Pipe Clamps and Pipe Hangers — Series 500/700/800

Pipe Hangers

CL-710

Light Duty Adjustable Clevis

Carbon steel

Used on non-insulated, stationary pipe lines. A lock nut above the clevis yoke is required to assure full rated load.

Complies with Federal Spec. WW-H-171E and SP-69, Type 12.

Order by Prod. # and pipe size.

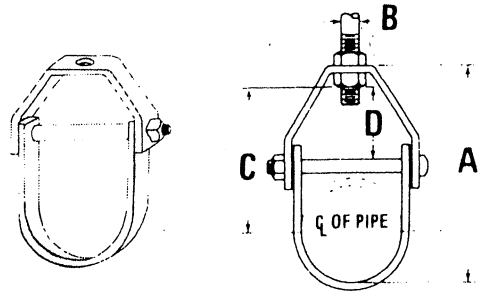

DIMENSIONS (inches) - WEIGHTS - LOADS

Pipe Size	A	B	C	D	Bolt Size	Top Stock	Bottom Stock	Wt./C lbs.	Design Load lbs.
1/2	2 ¹³ / ₁₆	3/ ₈	1 ³ / ₁₆	1	1/4 x 2	13 ga x 7/8	13 ga x 7/8	20	150
3/4	3	3/ ₈	1 ⁷ / ₈	1	1/4 x 2	13 ga x 7/8	13 ga x 7/8	22	250
1	3 ⁵ / ₁₆	3/ ₈	2 ¹ / ₁₆	1	1/4 x 2	13 ga x 7/8	13 ga x 7/8	24	250
1-1/4	3 ¹¹ / ₁₆	3/ ₈	2 ¹ / ₄	1	1/4 x 2-1/4	13 ga x 7/8	13 ga x 7/8	26	250
1-1/2	4	3/ ₈	2 ³ / ₈	1	1/4 x 2-3/4	13 ga x 7/8	13 ga x 7/8	28	250
2	4 ⁷ / ₁₆	3/ ₈	2 ³ / ₄	1	1/4 x 3-1/4	13 ga x 7/8	13 ga x 7/8	35	250
2-1/2	5 ³ / ₈	1/2	3 ¹ / ₄	1 ¹ / ₄	1/4 x 4-1/2	1/8 x 1-1/4	1/8 x 1-1/4	92	350
3	6	1/2	3 ¹ / ₂	1 ¹ / ₄	3/8 x 5-1/4	1/8 x 1-1/4	1/8 x 1-1/4	95	350
3-1/2	6 ⁵ / ₈	1/2	3 ³ / ₄	1 ¹ / ₄	3/8 x 5-3/4	1/8 x 1-1/4	1/8 x 1-1/4	114	350
4	7 ¹ / ₂	5/ ₈	4 ¹ / ₄	1 ¹ / ₂	3/8 x 6-1/4	3/16 x 1-1/4	1/8 x 1-1/4	140	400

CTL-710

Light Duty Adjustable Clevis

Carbon steel, copper plated.

For non-insulated copper tubing. Provide a lock nut above the clevis yoke to assure full rated load.

Complies with Federal Spec. WW-H-171E and SP-69, Type 12.

Order by Prod. #, nominal tubing, size.

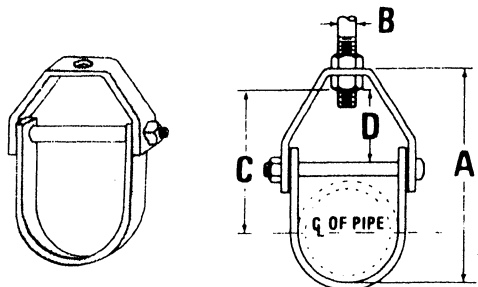

DIMENSIONS (inches) - WEIGHTS - LOADS

Nominal Tubing Size	A	B	C	D	Size of Steel	Wt./C lbs.	Design Load lbs.
1/2	2 ¹ / ₁₆	3/ ₈	1	1/2	1/16 x 3/4	11	150
3/4	2 ³ / ₈	3/ ₈	1 ³ / ₁₆	9/ ₁₆	1/16 x 3/4	12	250
1	2 ³ / ₄	3/ ₈	1 ³ / ₈	9/ ₁₆	3/32 x 7/8	26	250
1-1/4	3 ³ / ₈	3/ ₈	1 ⁷ / ₈	7/ ₈	3/32 x 7/8	29	250
1-1/2	3 ⁷ / ₈	3/ ₈	2 ¹ / ₄	1 ¹ / ₁₆	3/32 x 7/8	33	250
2	4 ¹³ / ₁₆	3/ ₈	3 ¹ / ₁₆	1 ⁹ / ₁₆	3/32 x 7/8	37	250
2-1/2	6	1/2	3 ⁷ / ₈	2 ¹ / ₈	1/8 x 1 1/4	76	350
3	6 ³ / ₈	1/2	4	1 ⁷ / ₈	1/8 x 1 1/4	94	350
3-1/2	6 ¹³ / ₁₆	1/2	4	1 ¹³ / ₁₆	1/8 x 1 1/4	94	350
4	7 ³ / ₄	1/2	4 ⁵ / ₈	2 ¹ / ₁₆	1/8 x 1 1/4	101	400

Beam Clamps, Pipe Clamps and Pipe Hangers — SECTION 5

Series 500/700/800

Pipe Hangers

C-711

Pipe Hanger

Complies with Specification SP 58.
Type 5.

Sizes through 5" conform to Ca. Code
Title 24, Div. T22 for Seismic restraint
bracing.

Order by Prod. # and pipe size.

C-711-F

Pipe Hanger - Felt Lined

Order by Prod. #, pipe size.

C-711-P

Pipe Hanger - Plastic Coated

Plastic coated. Isolated hanger from
glass and other piping for corrosion or
cushioning purposes.

Order by Prod. #, pipe size.

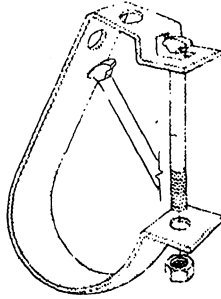

DIMENSIONS (inches) - WEIGHTS - LOADS

Size	A	B	C	WT/C	Load
1/2	1 3/4	3/8	7/16	17	350
3/4	2	3/8	7/16	18	350
1	2 1/4	3/8	7/16	20	350
1 1/4	2 5/8	3/8	7/16	23	450
1 1/2	2 3/4	3/8	7/16	24	450
2	3 3/16	3/8	7/16	28	450
2 1/2	4 1/2	1/2	9/16	30	700
3	5	1/2	9/16	76	800
3 1/2	5 1/2	1/2	9/16	81	800
4	6	5/8	5/8	120	1000
5	6	5/8	9/16	154	1200
6	7	3/4	9/16	219	1200
8	10	7/8	9/16	300	1510
10	12	7/8	9/16	365	1550
12	14	7/8	9/16	430	1675

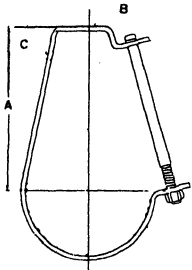

C. Hole provided for
side mounting to
wall as bracket.

Hangers 6" and over have hole instead of slot.

Saddles, Shields and Rollers

C-728

Pipe Roller (Pair)

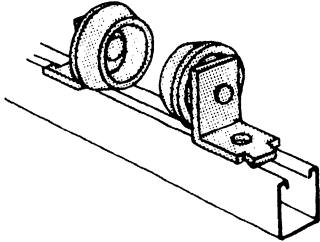

Design Load 2350 lbs.

Designed for standard saddles. Order separately for each pair rollers:

Two 1/2 x 15/16 hex head cap screws
Two 1/2" channel nuts

Space to suit O.D. of pipe and wrapping.

Material: Cast aluminum rollers, steel brackets.

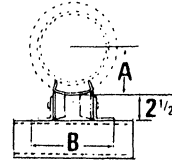

A Max. OS Radius	B
3-3/8	6-3/4
4-5/8	7-1/2
6-3/8	8-1/2
8-1/2	9-9/16

wt./C 300 lbs.

C-728-H

Pipe Roller Assembly

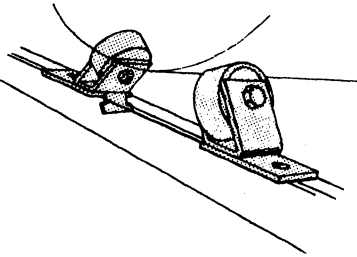

Design Load 3920 lbs.

For support of 6" through 18" pipe. Order separately for each pair of rollers:

Two 1/2" x 15/16" hex head cap screws
Two 1/2" channel nuts

Space to suit O.D. of pipe.

Material: Cast aluminum roller, steel brackets.

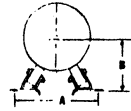

Pipe Size	A	B
6	10 ^{13/16}	6 ^{9/16}
8	11 ^{13/16}	7 ^{7/8}
10	12 ^{7/8}	8 ^{5/16}
12	13 ^{7/8}	9 ^{3/16}
14	14 ^{1/2}	9 ^{9/16}
16	15 ^{1/2}	10 ^{9/16}
18	16 ^{1/2}	11 ^{7/16}

wt./C 294 lbs.

SECTION 5 Beam Clamps, Pipe Clamps and Pipe Hangers — Series 500/700/800

Seismic Bracing

C-749-N
Seismic Brace

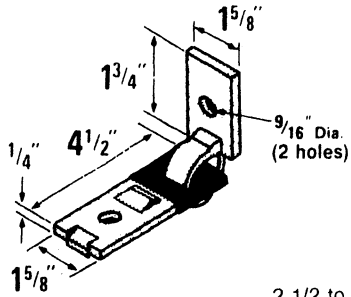

2000 lb. load
2-1/2 to 1 safety factor
wt./C 89 lbs.

C-749-N-5/8
Seismic Brace

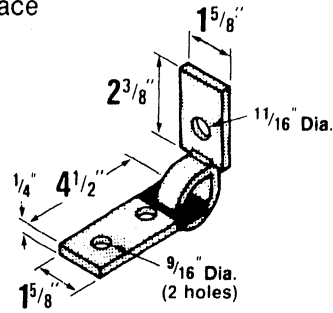

2000 lb. load
2-1/2 to 1 safety factor
wt./C 94 lbs.

C-749-N-7/8
Seismic Brace

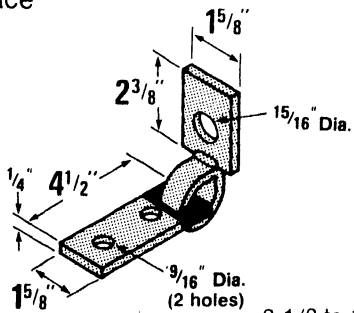

2000 lb. load
2-1/2 to 1 safety factor
wt./C 92 lbs.

C-749-N-1-1/8
Seismic Brace

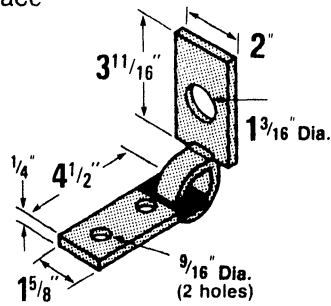

2000 lb. load
2-1/2 to 1 safety factor
wt./C 116 lbs.

All braces have plastisol coating on the flat member.

Plastisol insulates against vibration noise transmission and eliminates rattle at the connection points.

PG-795
Pipe Block

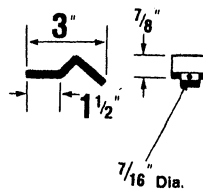
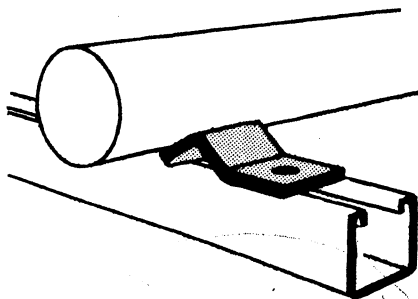

wt./C 40 lbs.

Materials

Superstrut electrical raceway, fixture hanging channel, closure strip and accessories are manufactured from hot rolled strip steel.

Design Data

Deflections at various hanger rod spacings for raceway channels—based on 40 to 45 lbs. per fixture.

Channel	Deflection at 10 ft.	Deflection at 12 ft.	Deflection at 14 ft.
A-1200	1/4"	1/2"	3/4"
C-1200	3/8"	3/4"	.
A-1400	3/8"	3/4"	.

	Deflection at 6 ft.	Deflection at 7 ft.	Deflection at 9 ft.
B-1200	3/8"	9/16"	5/8"
B-1400	1"	1/2"	.

*Not recommended for this spacing.

Electrical Raceway

Superstrut channel together with snap in closure strip is listed by Underwriters Laboratories as a surface metal raceway. Other accessories listed by Underwriters Laboratories are identified on the drawings.

MAXIMUM NUMBER OF WIRES

Wire Size Avg	Raceway With or Without KO		Raceway With or Without KO		Raceway	
	A-1200	A-1400	C-1200	B-1400	A	B
14	10	6	10	5	5	4
12	10	6	10	4	6	3
10	8	5	6	4		
8	6	4	4	3		
6	3	2	2	2		

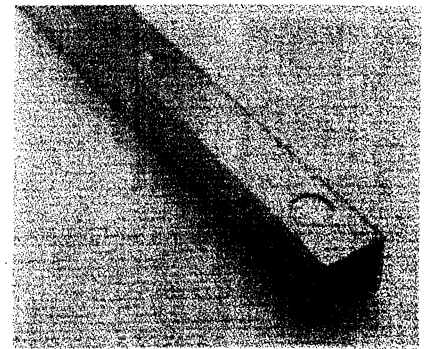
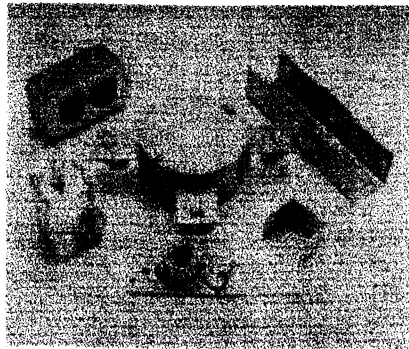

COLUMN A Suitable for number of wires indicated when used as a raceway. Also suitable for number of wires indicated when installed to support and supply electric discharge type fixtures when raceway wiring is suitable for not less than 75°C.

By providing clearance between fixture and raceway of not less than 1/2", wire suitable for 60°C may be used.

COLUMN B Suitable for number of wires indicated when used as a raceway. Also suitable for number of wires indicated when installed to support electric discharge type fixtures when clearance of not less than 1/8" is provided between raceway and fixture and when wiring is suitable for 75°C.

PAGE

•Electrical Applications 44
•Fixture Fittings 47

Electrical Applications

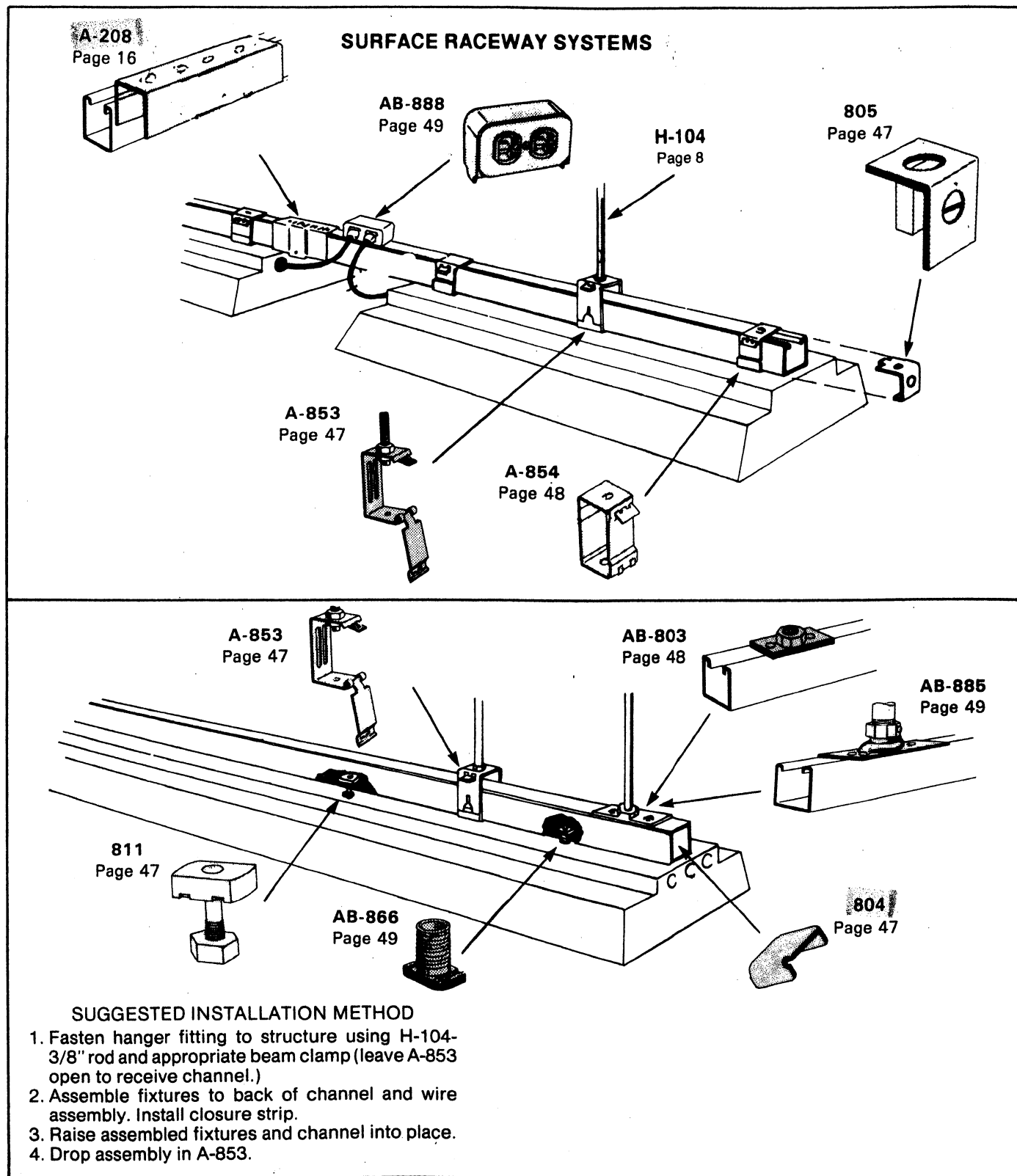

44 For hanger spacing greater than 12 feet use a deeper channel section: E-1200 up to 16 feet or H-1200 over 16 feet.

Electrical Applications

SLOTTED CHANNEL SYSTEM
Support System Only, not a raceway.

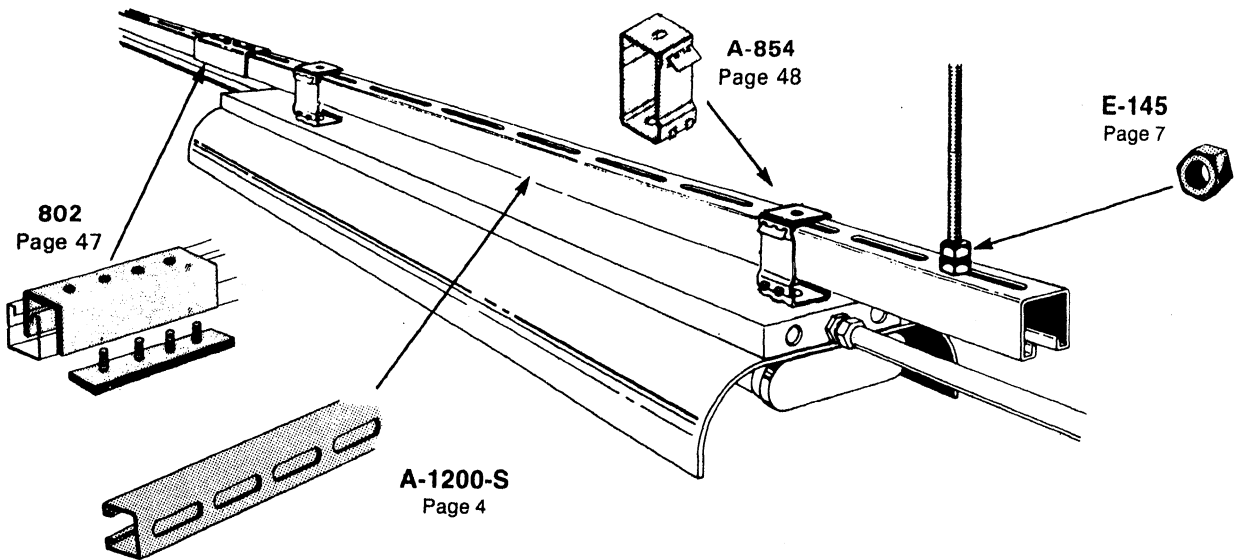

GRID SYSTEM

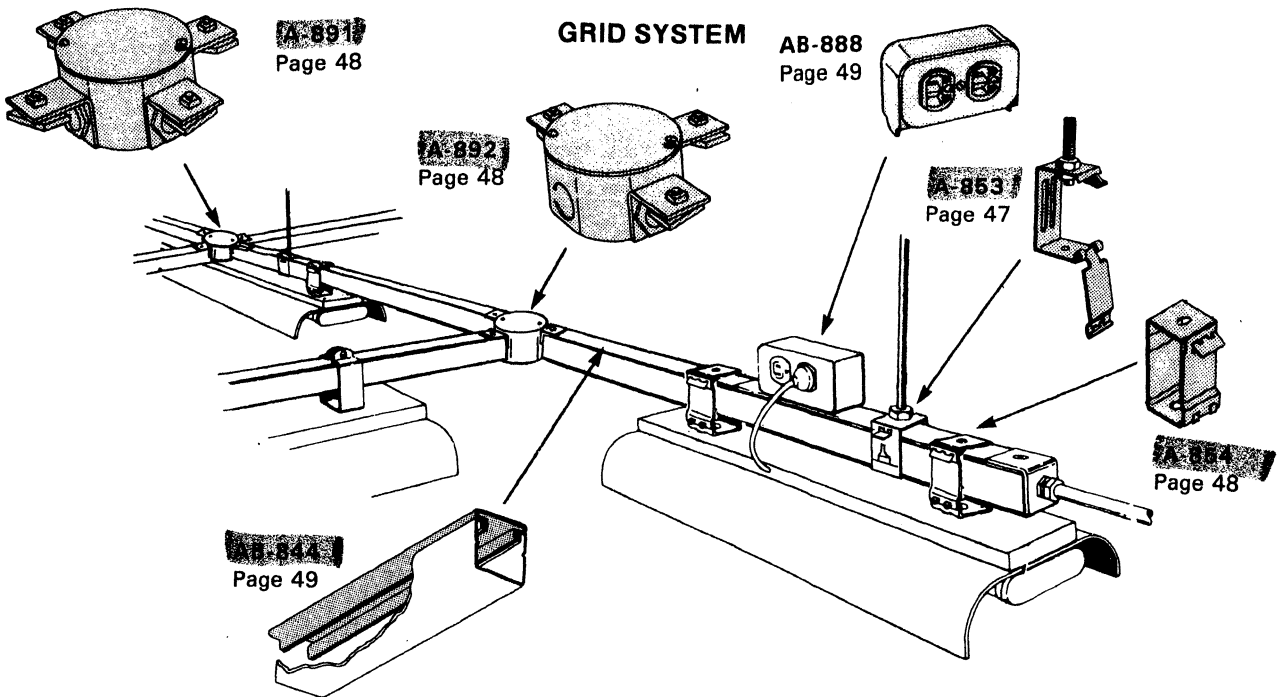

Electrical Applications

SUPPORT SYSTEM

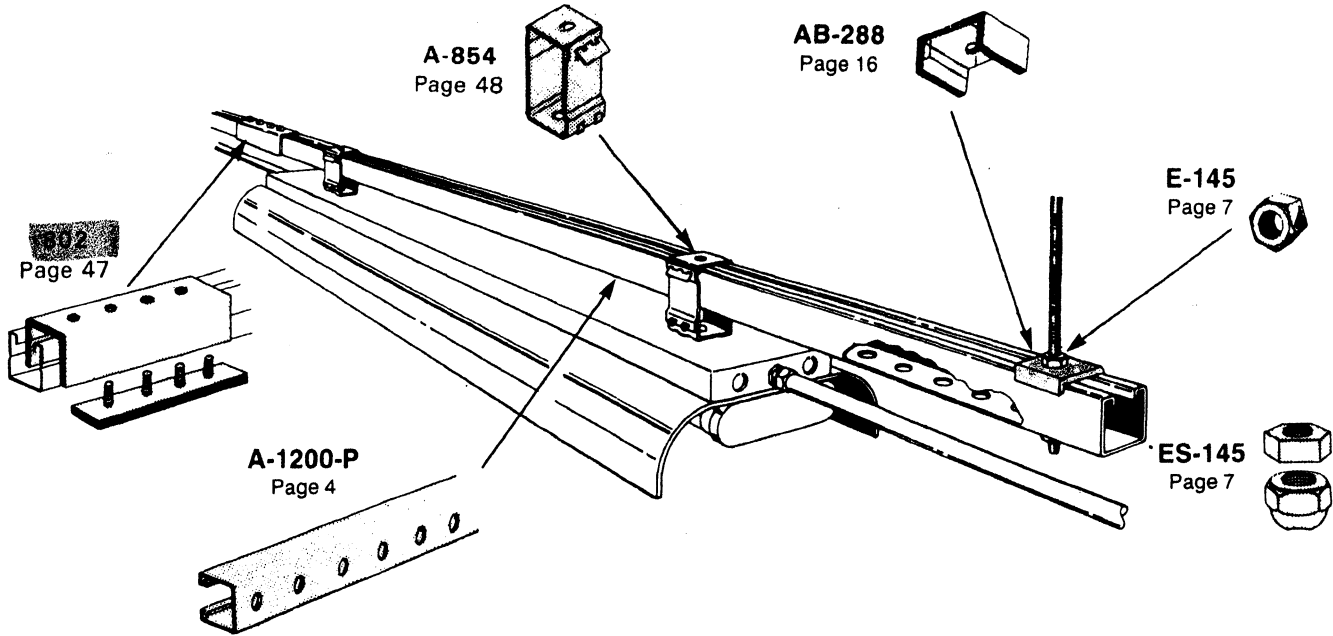

SUPPORT SYSTEM

A few suggested ways to fasten rod to structure using channel as support system only.

Concrete Spot Insert
Page 22

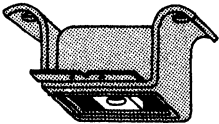

Order nuts separately

540
Side Beam
Hanger Clip
Page 32

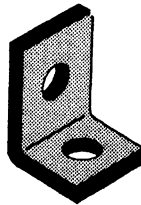

S-541
Swing Connector
Page 32

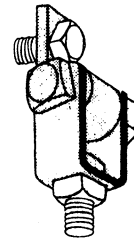

U-550
Beam Clamp
Page 32

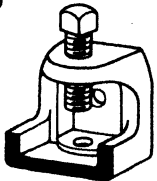

US-563
Beam Clamp
Page 33

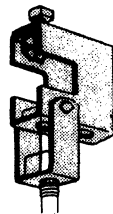

Beam Clamp with Safety Rod
Page 34

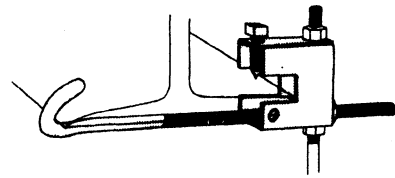



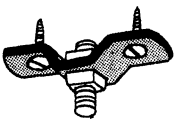

Ceiling Flange
Page 34

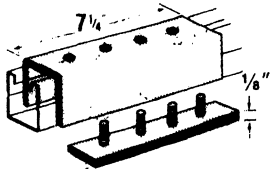

SECTION 6

Surface Raceway and Lighting Systems — Series 800

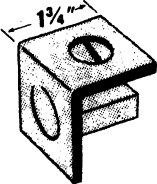
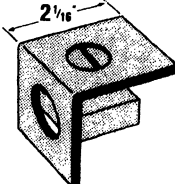
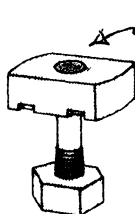
Fixture Fittings

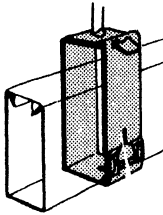
	<p>A-802 Raceway Joiner With Reinforcing Plate</p>  <p>Furnished complete with nuts.</p> <table border="1"> <thead> <tr> <th>Prod. #</th> <th>For Channel</th> <th>Wt./C lbs.</th> </tr> </thead> <tbody> <tr> <td>A-802</td> <td>A Series</td> <td>158</td> </tr> <tr> <td>B-802</td> <td>B Series</td> <td>112</td> </tr> <tr> <td>E-802</td> <td>E Series</td> <td>170</td> </tr> <tr> <td>H-802</td> <td>H Series</td> <td>182</td> </tr> </tbody> </table>	Prod. #	For Channel	Wt./C lbs.	A-802	A Series	158	B-802	B Series	112	E-802	E Series	170	H-802	H Series	182	<p>A-804 End Cap</p>  <table border="1"> <thead> <tr> <th>Prod. #</th> <th>For Channel</th> <th>Wt./C lbs.</th> </tr> </thead> <tbody> <tr> <td>*A-804</td> <td>A-1200</td> <td>10</td> </tr> <tr> <td></td> <td>A-1400</td> <td>10</td> </tr> <tr> <td>*B-804</td> <td>B-1400</td> <td>5</td> </tr> <tr> <td>*C-804</td> <td>C-1200</td> <td>8</td> </tr> <tr> <td>*E-804</td> <td>E-1200</td> <td>15</td> </tr> <tr> <td>*H-804</td> <td>H-1200</td> <td>20</td> </tr> </tbody> </table>	Prod. #	For Channel	Wt./C lbs.	*A-804	A-1200	10		A-1400	10	*B-804	B-1400	5	*C-804	C-1200	8	*E-804	E-1200	15	*H-804	H-1200	20
Prod. #	For Channel	Wt./C lbs.																																				
A-802	A Series	158																																				
B-802	B Series	112																																				
E-802	E Series	170																																				
H-802	H Series	182																																				
Prod. #	For Channel	Wt./C lbs.																																				
*A-804	A-1200	10																																				
	A-1400	10																																				
*B-804	B-1400	5																																				
*C-804	C-1200	8																																				
*E-804	E-1200	15																																				
*H-804	H-1200	20																																				
<p>A-805 End Cap With Knockout</p>  <p>KO for 1/2" conduit. Furnished complete with 1/4 x 5/8 flat head machine screw and AB-100-1/4 nut.</p> <table border="1"> <thead> <tr> <th>Prod. #</th> <th>For Channel</th> <th>Wt./C lbs.</th> </tr> </thead> <tbody> <tr> <td>*A-805</td> <td>A Series</td> <td>21</td> </tr> <tr> <td>*C-805</td> <td>C Series</td> <td>20</td> </tr> <tr> <td>E-805</td> <td>E Series</td> <td>30</td> </tr> <tr> <td>H-805</td> <td>H Series</td> <td>31</td> </tr> </tbody> </table>	Prod. #	For Channel	Wt./C lbs.	*A-805	A Series	21	*C-805	C Series	20	E-805	E Series	30	H-805	H Series	31	<p>A-809 Tapped End Cap</p>  <p>12 ga. for 3/4" or 1" conduit. Furnished complete with 1/4 x 5/8 flat head machine screw and AB-100-1/4 nut.</p> <table border="1"> <thead> <tr> <th>Prod. #</th> <th>For Channel</th> <th>Wt./C lbs.</th> </tr> </thead> <tbody> <tr> <td>*A-809-3/4</td> <td>A Series</td> <td>25</td> </tr> <tr> <td>*A-809-1</td> <td>A Series</td> <td>24</td> </tr> </tbody> </table>	Prod. #	For Channel	Wt./C lbs.	*A-809-3/4	A Series	25	*A-809-1	A Series	24	<p>811 Stud Nut</p>  <p>For attaching fixture to slot down channel or to slot up knockouts. Specify length. Hex nut included.</p> <table border="1"> <thead> <tr> <th>Prod. #</th> <th>Size</th> <th>Wt./C lbs.</th> </tr> </thead> <tbody> <tr> <td>811-1</td> <td>1/4 x 3/4</td> <td>8</td> </tr> <tr> <td>811-2</td> <td>1/4 x 1-1/4</td> <td>9</td> </tr> </tbody> </table>	Prod. #	Size	Wt./C lbs.	811-1	1/4 x 3/4	8	811-2	1/4 x 1-1/4	9			
Prod. #	For Channel	Wt./C lbs.																																				
*A-805	A Series	21																																				
*C-805	C Series	20																																				
E-805	E Series	30																																				
H-805	H Series	31																																				
Prod. #	For Channel	Wt./C lbs.																																				
*A-809-3/4	A Series	25																																				
*A-809-1	A Series	24																																				
Prod. #	Size	Wt./C lbs.																																				
811-1	1/4 x 3/4	8																																				
811-2	1/4 x 1-1/4	9																																				
	<p>A-853 Channel Hanger</p>  <p>Use hanger rod 3/8" or 1/2". Use with "A," "B" or "C" series single channel.</p> <p>wt./C 25 lbs.</p>	<p>A-853-L Channel Hanger-Long</p>  <p>Long type for all series channel</p> <p>wt./C 48 lbs.</p>																																				

Fixture Fittings

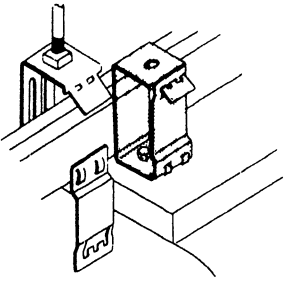
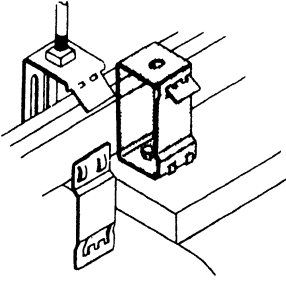
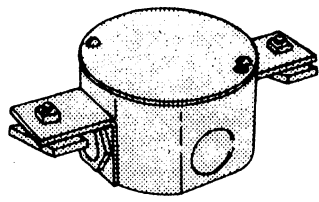
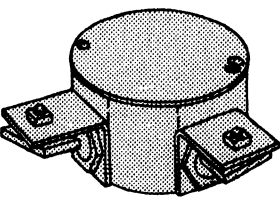
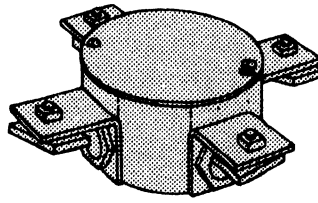
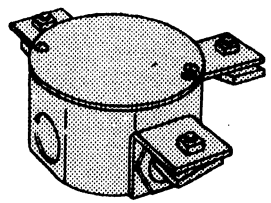
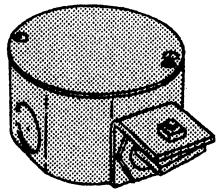
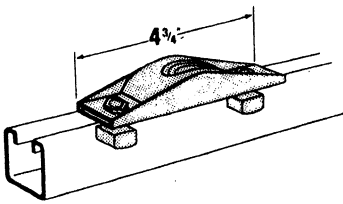
<p>A-854 Channel Hanger</p>  <p>Illustration showing A-854 with nut and bolt furnished to attach to florescent fixture. Use with "A," "B" or "C" series single channel.</p> <p>wt./C 34 lbs.</p>	<p>A-854-L Channel Hanger-Long</p>  <p>Illustration showing A-854-L with nut and bolt furnished to attach to florescent fixture. Long type for all series channel</p> <p>wt./C 51 lbs.</p>	<p>A-889</p>  <p>wt./C 120 lbs.</p>
<p>A-890</p>  <p>wt./C 120 lbs.</p>	<p>A-891</p>  <p>wt./C 140 lbs.</p>	<p>A-892</p>  <p>wt./C 130 lbs.</p>
<p>A-893</p>  <p>wt./C 110 lbs.</p>		<p>AB-815 Swing Connector</p>  <p>Nuts & bolts to clamp to channel included.</p> <p>For 1/2" or 3/4" conduit.</p> <p>wt./C 95 lbs.</p>

SECTION 6

Surface Raceway and Lighting Systems — Series 800

Fixture Fittings

*AB-844

Steel Closure Strip

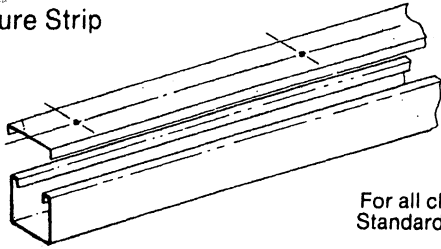

When used as a raceway channel is normally installed with the slot up and after wiring is complete the closure strip is installed.

For all channel.
Standard lengths 10 ft.

AB-866

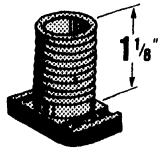

1/2" Pipe thread.

wt./C 21 lbs.

AB-885

Swivel

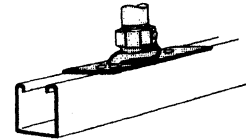

Nuts and bolts to clamp to channel included. For 1/2" or 3/4" conduit.

wt./C 25 lbs.

*AB-887

Single Outlet

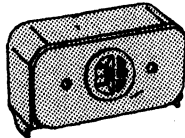

Complete unit including housing, standard SINGLE 3-wire, 15 Amp., 125 volt, NEMA ground receptacle and cover plate.

wt./C 50 lbs.

*AB-888

Duplex Outlet

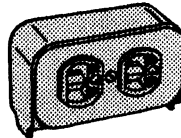

Complete unit including housing, standard DUPLEX 3-wire, 15 Amp., 125 volt, NEMA ground receptacle and cover plate.

wt./C 55 lbs.

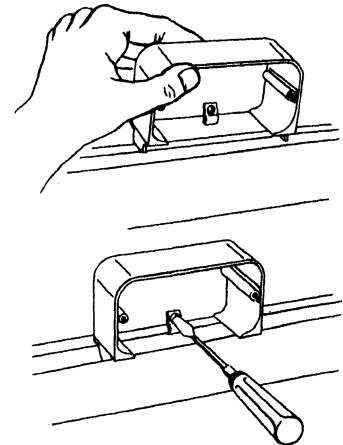

ALUMINUM CHANNEL		
PRODUCT NUMBER	WGT. 100 FT	PCS/ BUNDLE
A 1200	71	50
A 1200 HS	70	50
A 1202	135	30
Available in 10' and 20' Lengths		

STEEL CHANNEL		
PRODUCT NUMBER	WGT. 100 FT	PCS/ BUNDLE
A 1200	190	50
A 1200 S	180	50
A 1200 HS	185	50
A 1200 P	185	50
A 1200 KO	190	50
A 1202	380	30
B 1200	128	100
B 1200 HS	123	100
B 1200 P	123	100
B 1200 S	118	100
B 1202	256	50
Available in 10' and 20' Lengths		

ELECTRO-GALVANIZED			
PRODUCT NUMBER	SIZE	WGT. PER 100 PCS.	PCS/ CARTON
A 100 Spring Nut	1/4	7	200
	3/8	10	200
	1/2	12	200

ELECTRO-GALVANIZED				
PRODUCT NUMBER	SIZE	WGT. PER 100 PCS.	PCS/ CARTON	BULK
702 Conduit Clamp	1/2	11	100	800
	3/4	15	100	800
	1	17	100	800
	1 1/4	18	75	600
	1 1/2	29	75	600
	2	34	50	500
	2 1/2	40	50	500
	3	47	25	400
	3 1/2	62	25	400
	4	67	25	400
	6	80	25	300

**Properties for Design
Aluminum Channel**

Elements of Sections

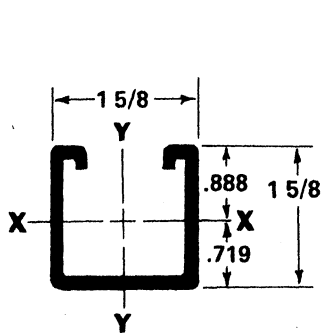

A-1200 AL

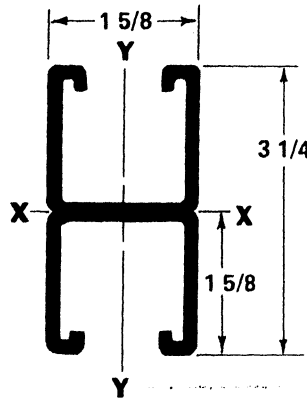

A-1202 AL

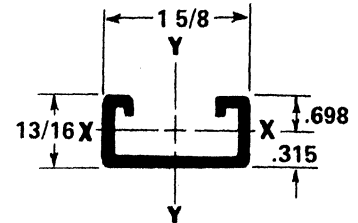

B-1200 AL

12 GA. = .105"

I - Moment of Inertia
S - Section Modulus
r - Radius of Gyration
A - Area

Calculations based on maximum fibre stress of 10,000 PSI, maximum deflection 1/360th of span. For concentrated loads, multiply load by 0.50

SECTION	X - X AXIS					Y - Y AXIS			
	MEMBER	WT.	A	I	S	r	I	S	r
	lbs./ft.	In. ²	In. ⁴	In. ³	In.	In. ⁴	In. ²	In.	
A-1200	.662	.563	.198	.224	.594	.274	.338	.698	
B-1200	.470	.400	.041	.082	.320	.150	.185	.612	
A-1202	1.115	.983	1.001	.620	1.013	.465	.826	.688	

SAFE UNIFORM TOTAL LOAD TABLE				TYPICAL PHYSICAL AND MECHANICAL PROPERTIES AND CHARACTERISTICS	
SPAN (inches)	B-1200-AL (lbs.)	A-1200-AL (lbs.)	A-1202-AL (lbs.)	ALLOY AND TEMPER	6063-T6
12	540	1490	4130	TENSILE-STRENGTH:	YIELD — 25,000 PSI
18	270	990	2760		ULTIMATE - 30,000 PSI
24	150	730	2070	SHEAR - ULTIMATE:	19,000 PSI
30	90	470	1650	ELONGATION: (PERCENT IN 2 INCHES) -	12
36	60	320	1370	DENSITY:	0.098 LBS./CU. INCH
42	50	240	1180	MODULUS OF ELASTICITY	10 x 10 ⁶ PSI
48	—	180	930		
54	—	140	730		
60	—	110	590		
72	—	80	410		
84	—	60	300		
96	—	40	230		
108	—	30	180		
120	—	20	140		

Stainless Steel Channel

Elements of sections are the same as shown on Page 59 for standard steel channel. Load ratings meet or exceed ratings for standard steel channel shown elsewhere in this catalog.

Design Data - Metal Framing Channel

TABLE 1

Properties for Design

Elements of Sections

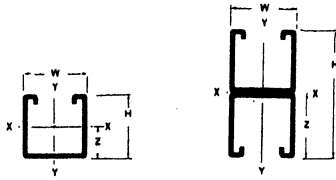

Single Channels Double Channels

Nominal Thickness (inches)

12 GA = .105
14 GA = .075
16 GA = .060

I - Moment of inertia
S - Section Modulus
r - Radius of Gyration
Z - Nominal Axis
A - Area

SECTION	X - X AXIS						Y - Y AXIS					
	MEMBER	WT.	H	W	A	I	S	r	Z	I	S	r
	lbs./ft.	in.	in.	in. ²	in. ⁴	in. ³	in.	in.	in. ⁴	in. ³	in.	
SINGLE CHANNEL												
A-1200	1.90	1.625	1.625	.557	.192	.212	.587	.237	.237	.292	.652	
B-1200	1.28	.813	1.625	.381	.031	.063	.283	.331	.137	.168	.600	
C-1200	1.70	1.375	1.625	.500	.121	.155	.492	.595	.205	.252	.640	
E-1200	2.47	2.438	1.625	.726	.529	.399	.853	1.112	.335	.413	.679	
H-1200	3.05	3.250	1.625	.897	1.100	.635	1.107	1.507	.436	.536	.697	
A-1400	1.40	1.625	1.625	.401	.134	.146	.577	.707	.184	.226	.677	
B-1400	.97	.813	1.625	.280	.024	.051	.295	.338	.103	.127	.607	
DOUBLE CHANNEL												
A-1202	3.80	3.250	1.625	1.114	.948	.583	.851	1.625	.474	.584	.652	
B-1202	2.56	1.626	1.625	.782	.147	.181	.439	.813	.274	.337	.600	
C-1202	3.40	2.750	1.625	1.000	.595	.433	.772	1.375	.409	.504	.640	
E-1202	4.94	4.876	1.625	1.450	2.854	1.171	1.402	2.438	.672	.827	.680	
H-1202	6.10	6.500	1.625	1.794	6.273	1.930	1.870	3.250	.871	1.072	.697	
A-1402	2.80	3.250	1.625	.801	.668	.411	.913	1.625	.367	.452	.677	
B-1402	1.94	1.626	1.625	.580	.112	.138	.447	.813	.206	.254	.607	

TABLE 2

Load ratings for 1/2" strut nuts used in Superstrut Channel

If connections will be subjected to dynamic or seismic load conditions, contact the factory for design assistance.

Channel No.	Slip Resistance lbs.	Pull Out Strength lbs.
A-1200	1500	2000
C-1200	1500	2000
B-1200	1400	1400
A-1400	1000	1400
B-1400	1000	1400

Safety Factor of 3

TABLE 3

Design loads for channel used as beam or column

BEAM LOADS

Table 3 contains simple beam, uniformly-distributed loads calculated at 25,000 psi fiber stress. Loads are also listed at reduced deflections for long spans.

Maximum loads @ 25,000 psi stress

Maximum allowable deflections and Maximum uniform loads for all spans @ 25,000 psi fiber stress.

Reduced load for all 1/180 Span Deflection

For moderate deflections on the longer spans, reduced loads are listed which will produce a deflection equal to 1/180 of the span. When maximum loads do not induce deflections exceeding 1/180 x the span length reduced loads are not required.

Reduced load for 1/360 Span Deflection

For very slight deflections on the longer spans, reduced loads are listed which will produce a deflection equal to 1/360 of the span. When maximum loads do not induce deflections exceeding 1/360 x the span length reduced loads are not required.

Concentrated loads

To obtain values for concentrated loads from Table 3, divide uniform load by 2 and deflection by 0.8.

Slotted, Punched, or KO Channel

Reduce load rating 5%

Long span deep beams.

Support in a manner to prevent rotation at supports and tie between supports to prevent twist.

COLUMN LOADS

Allowable column loads given are for axial loading with pinned ends. For eccentric loading or other end conditions reduce allowable loads according to standard engineering practice.

DYNAMIC LOADS

Allowable dynamic loads may be calculated by dividing the static loads shown in Table 3, by 2.08.

SECTION 9

Engineering Data and Specifications

Design Data - Metal Framing Channel

TABLE 3 continued

SINGLE CHANNEL										DOUBLE CHANNELS (Single Channels welded back to back)									
Prod. #	Depth	Ga.	Maximum Uniform		1/180 Span		1/360 Span		Col. Load	Prod. #	Depth	Ga.	Maximum Uniform		1/180 Span		1/360 Span		Col. Load
			Load	Defl.	Load	Defl.	Load	Defl.					Load	Defl.	Load	Defl.	Load	Defl.	
12" BEAM OR COLUMN																			
A-1200	1-5/8	12	3,534	.014		.067		.033	10,533	A-1202	3-1/4	12		.008		.067		.033	21,177
B-1200	13/16	12	1,050	.026		.067		.033	6,683	B-1202	1-5/8	12	3,016	.016		.067		.033	14,110
C-1200	1-3/8	12	2,584	.016		.067		.033	9,345	C-1202	2-3/4	12		.010		.067		.033	18,990
E-1200	2-7/16	12	6,650	.010		.067		.033	13,830	E-1202	4-7/8	12		.005		.067		.033	27,623
H-1200	3-1/4	12	10,583	.008		.067		.033	17,106	H-1202	6-1/2	12		.004		.067		.033	34,210
A-1400	1-5/8	14	2,434	.015		.067		.033	7,575	A-1402	3-1/4	14		.008		.067		.033	15,250
B-1400	13/16	14	850	.028		.067		.033	4,950	B-1402	1-5/8	14	2,300	.016		.067		.033	10,390
18" BEAM OR COLUMN																			
A-1200	1-5/8	12	2355	.033		.100		.050	10,210	A-1202	3-1/4	12		.018		.100		.050	20,609
B-1200	13/16	12	700	.059		.100		.050	6,058	B-1202	1-5/8	12	2,011	.036		.100		.050	13,440
C-1200	1-3/8	12	1,723	.038		.100		.050	8,970	C-1202	2-3/4	12	4,811	.021		.100		.050	18,470
E-1200	2-7/16	12	4,434	.023		.100		.050	13,482	E-1202	4-7/8	12		.013		.100		.050	16,926
H-1200	3-1/4	12	7,055	.016		.100		.050	16,693	H-1202	6-1/2	12		.009		.100		.050	33,390
A-1400	1-5/8	14	1,623	.031		.100		.050	7,334	A-1402	3-1/4	14		.018		.100		.050	14,867
B-1400	13/16	14	566	.063		.100	453	.050	4,150	B-1402	1-5/8	14	1,534	.036		.100		.050	9,910
24" BEAM OR COLUMN																			
A-1200	1-5/8	12	1,766	.058		.133		.067	9,842	A-1202	3-1/4	12	4,858	.031		.133		.067	19,974
B-1200	13/16	12	525	.105		.133	333	.067	5,315	B-1202	1-5/8	12	1,509	.064		.133		.067	12,670
C-1200	1-3/8	12	1,291	.066		.133		.067	8,545	C-1202	2-3/4	12	3,609	.038		.133		.067	17,890
E-1200	2-7/16	12	3,325	.039		.133		.067	13,082	E-1202	4-7/8	12		.021		.133		.067	26,143
H-1200	3-1/4	12	5,291	.030		.133		.067	16,277	H-1202	6-1/2	12		.016		.133		.067	32,435
A-1400	1-5/8	14	1,216	.056		.133		.067	7,058	A-1402	3-1/4	14	3,425	.033		.133		.067	14,426
B-1400	13/16	14	425	.110		.133	258	.067	4,000	B-1402	1-5/8	14	1,150	.064		.133		.067	9,350
30" BEAM OR COLUMN																			
A-1200	1-5/8	12	1,414	.089		.167		.083	9,419	A-1202	3-1/4	12	3,886	.049		.167		.083	19,261
B-1200	13/16	12	420	.164		.167	266	.083	4,465	B-1202	1-5/8	12	1,206	.100		.167		.083	11,803
C-1200	1-3/8	12	1,034	.104		.167	1,040	.083	8,060	C-1202	2-3/4	12	2,886	.059		.167		.083	17,230
E-1200	2-7/16	12	2,660	.063		.167		.083	12,640	E-1202	4-7/8	12	7,806	.034		.167		.083	25,259
H-1200	3-1/4	12	4,234	.046		.167		.083	15,698	H-1202	6-1/2	12		.025		.167		.083	31,395
A-1400	1-5/8	14	974	.088		.167		.083	6,753	A-1402	3-1/4	14	2,740	.050		.167		.083	13,937
B-1400	13/16	14	340	.172		.167	165	.083	3,420	B-1402	1-5/8	14	920	.100		.167		.083	8,730

When no numbers are shown, use the maximum uniform load.
deflections - in inches loads - in lbs.

Design Data - Metal Framing Channel
TABLE 3 continued

SINGLE CHANNEL										DOUBLE CHANNELS (Single Channels welded back to back)									
Prod. #	Depth	Ga.	Maximum Uniform		1/180 Span		1/360 Span		Col. Load	Prod. #	Depth	Ga.	Maximum Uniform		1/180 Span		1/360 Span		Col. Load
			Load	Defl.	Load	Defl.	Load	Defl.					Load	Defl.	Load	Defl.	Load	Defl.	
36" BEAM OR COLUMN																			
A-1200	1-5/8	12	1,178	.129		.200	917	.100	8,962	A-1202	3-1/4	12	3,239	.071		.200		.100	18,470
B-1200	13/16	12	350	.236		.200	148	.100	3,498	B-1202	1-5/8	12	1,005	.144		.200	702	.100	10,840
C-1200	1-3/8	12	861	.149		.200	578	.100	7,525	C-1202	2-3/4	12	2,400	.085		.200		.100	16,500
E-1200	2-7/16	12	2,216	.088		.200		.100	12,160	E-1202	4-7/8	12	6,505	.048		.200		.100	24,316
H-1200	3-1/4	12	3,528	.068		.200		.100	15,132	H-1202	6-1/2	12		.036		.200		.100	30,265
A-1400	1-5/8	14	811	.126		.200	640	.100	6,416	A-1402	3-1/4	14	2,284	.071		.200		.100	13,416
B-1400	13/16	14	284	.248		.200	115	.100	2,755	B-1402	1-5/8	14	766	.144		.200	535	.100	8,050
42" BEAM OR COLUMN																			
A-1200	1-5/8	12	1,010	.175		.233	674	.117	8,466	A-1202	3-1/4	12	2,776	.098		.233		.117	17,635
B-1200	13/16	12	300	.323	217	.233	109	.117	2,579	B-1202	1-5/8	12	863	.195		.233	516	.117	9,790
C-1200	1-3/8	12	738	.203		.233	425	.117	6,945	C-1202	2-3/4	12	2,063	.115		.233		.117	15,730
E-1200	2-7/16	12	1,900	.120		.233		.117	11,698	E-1202	4-7/8	12	5,576	.065		.233		.117	23,272
H-1200	3-1/4	12	3,024	.091		.233		.117	14,514	H-1202	6-1/2	12		.049		.233		.117	29,025
A-1400	1-5/8	14	695	.160		.233	470	.117	6,051	A-1402	3-1/4	14	1,958	.225		.233		.117	12,832
B-1400	13/16	14	243	.336	168	.233	84	.117	2,060	B-1402	1-5/8	14	658	.195		.233	393	.117	7,300
48" BEAM OR COLUMN																			
A-1200	1-5/8	12	884	.228		.267	516	.133	7,943	A-1202	3-1/4	12	2,429	.128		.267		.133	16,730
B-1200	13/16	12	263	.420	167	.267	83	.133	1,981	B-1202	1-5/8	12	754	.255		.267	395	.133	8,640
C-1200	1-3/8	12	646	.265		.267	325	.133	6,325	C-1202	2-3/4	12	1,804	.151		.267		.133	14,890
E-1200	2-7/16	12	1,663	.156		.267		.133	11,092	E-1202	4-7/8	12	4,879	.085		.267		.133	22,170
H-1200	3-1/4	12	2,646	.120		.267		.133	13,850	H-1202	6-1/2	12		.064		.267		.133	27,700
A-1400	1-5/8	14	609	.226		.267	360	.133	5,658	A-1402	3-1/4	14	1,713	.128		.267		.133	12,223
B-1400	13/16	14	213	.440	129	.267	64	.133	1,580	B-1402	1-5/8	14	575	.255		.267	301	.133	6,480
54" BEAM OR COLUMN																			
A-1200	1-5/8	12	785	.289		.300	408	.150	7,369	A-1202	3-1/4	12	2,159	.161		.300		.150	15,763
B-1200	13/16	12	234	.533	132	.300	66	.150	1,555	B-1202	1-5/8	12	670	.323		.300	312	.150	7,405
C-1200	1-3/8	12	574	.335		.300	257	.150	5,650	C-1202	2-3/4	12	1,604	.190		.300	1,263	.150	13,990
E-1200	2-7/16	12	1,478	.198		.300	1,123	.150	10,505	E-1202	4-7/8	12	4,338	.108		.300		.150	20,980
H-1200	3-1/4	12	2,351	.151		.300		.150	13,150	H-1202	6-1/2	12	7,149	.081		.300		.150	16,280
A-1400	1-5/8	14	541	.286		.300	284	.150	5,241	A-1402	3-1/4	14	1,523	.161		.300		.150	11,566
B-1400	13/16	14	189	.556	102	.300	51	.150	1,250	B-1402	1-5/8	14	511	.323		.300	238	.150	5,580

SECTION 9

Engineering Data and Specifications

Design Data - Metal Framing Channel

TABLE 3 continued

SINGLE CHANNEL										DOUBLE CHANNELS (Single Channels welded back to back)									
Prod. #	Depth	Ga.	Maximum Uniform		1/180 Span		1/360 Span		Col. Load	Prod. #	Depth	Ga.	Maximum Uniform		1/180 Span		1/360 Span		Col. Load
			Load	Defl.	Load	Defl.	Load	Defl.					Load	Defl.	Load	Defl.	Load	Defl.	
60" BEAM OR COLUMN																			
A-1200	1-5/8	12	706	.358		.333	330	.167	6,762	A-1202	3-1/4	12	1,944	.199		.333		.167	14,738
B-1200	13/16	12	210	.658	107	.333	53	.167	—	B-1202	1-5/8	12	604	.398		.333	253	.167	6,100
C-1200	1-3/8	12	516	.414		.333	208	.167	4,920	C-1202	2-3/4	12	1,444	.235		.333	1,023	.167	13,050
E-1200	2-7/16	12	1,330	.244		.333	909	.167	9,874	E-1202	4-7/8	12	3,904	.133		.333		.167	19,734
H-1200	3-1/4	12	2,116	.186		.333		.167	12,406	H-1202	6-1/2	12	6,434	.100		.333		.167	24,810
A-1400	1-5/8	14	486	.353		.333	231	.167	4,792	A-1402	3-1/4	14	1,370	.199		.333		.167	10,878
B-1400	13/16	14	170	.687	82	.333	41	.167	—	B-1402	1-5/8	14	460	.399		.333	193	.167	4,640
66" BEAM OR COLUMN																			
A-1200	1-5/8	12	643	.432		.367	273	.183	6,127	A-1202	3-1/4	12	1,766	.240		.367	1,347	.183	13,646
B-1200	13/16	12	191	.795	88	.367	44	.183	—	B-1202	1-5/8	12	549	.481	418	.367	209	.183	5,055
C-1200	1-3/8	12	470	.501	344	.367	172	.183	4,145	C-1202	2-3/4	12	1,313	.285		.367	846	.183	12,030
E-1200	2-7/16	12	1,210	.295		.367	753	.183	9,211	E-1202	4-7/8	12	3,549	.180		.367		.183	18,415
H-1200	3-1/4	12	1,924	.226		.367		.183	11,616	H-1202	6-1/2	12	5,849	.120		.367		.183	23,230
A-1400	1-5/8	14	443	.426		.367	190	.183	4,311	A-1402	3-1/4	14	1,245	.241		.367	949	.183	10,133
B-1400	13/16	14	155	.831	68	.367	35	.183	—	B-1402	1-5/8	14	419	.483	318	.367	159	.183	3,840
72" BEAM OR COLUMN																			
A-1200	1-5/8	12	589	.514	459	.400	229	.200	5,436	A-1202	3-1/4	12	1,620	.286		.400	1,132	.200	12,500
B-1200	13/16	12	175	.946	74	.400	37	.200	—	B-1202	1-5/8	12	503	.574	351	.400	176	.200	4,230
C-1200	1-3/8	12	430	.595	289	.400	144	.200	3,485	C-1202	2-3/4	12	1,203	.339		.400	710	.200	10,980
E-1200	2-7/16	12	1,108	.351		.400	632	.200	8,509	E-1202	4-7/8	12	3,253	.191		.400		.200	17,023
H-1200	3-1/4	12	1,839	.269		.400	1,313	.200	10,782	H-1202	6-1/2	12	5,361	.143		.400		.200	21,560
A-1400	1-5/8	14	405	.506	320	.400	160	.200	3,809	A-1402	3-1/4	14	1,141	.286		.400	798	.200	9,340
B-1400	13/16	14	141	.989	57	.400	29	.200	—	B-1402	1-5/8	14	384	.574	267	.400	134	.200	3,220
84" BEAM OR COLUMN																			
A-1200	1-5/8	12	505	.700	337	.467	168	.233	4,061	A-1202	3-1/4	12	1,388	.390		.467	832	.233	9,992
B-1200	13/16	12			54	.467	27	.233	—	B-1202	1-5/8	12	431	.780	258	.467	129	.233	3,100
C-1200	1-3/8	12	369	.811	212	.467	106	.233	2,565	C-1202	2-3/4	12	1,031	.461		.467	522	.233	8,670
E-1200	2-7/16	12	950	.479		.467	464	.233	6,991	E-1202	4-7/8	12	2,788	.260		.467		.233	13,993
H-1200	3-1/4	12	1,513	.366		.467	965	.233	8,988	H-1202	6-1/2	12	4,595	.195		.467		.233	17,975
A-1400	1-5/8	14	348	.691	235	.467	118	.233	2,827	A-1402	3-1/4	14	979	.390		.467	586	.233	7,682
B-1400	13/16	14			42	.467	21	.233	—	B-1402	1-5/8	14	329	.781	197	.467	98	.233	2,370

When no numbers are shown, use the maximum uniform load.
deflections - in inches loads - in lbs.

Design Data - Metal Framing Channel

TABLE 3 continued

SINGLE CHANNEL										DOUBLE CHANNELS (Single Channels welded back to back)									
Prod. #	Depth	Ga.	Maximum Uniform		1/180 Span		1/360 Span		Col. Load	Prod. #	Depth	Ga.	Maximum Uniform		1/180 Span		1/360 Span		Col. Load
			Load	Defl.	Load	Defl.	Load	Defl.					Load	Defl.	Load	Defl.			
96" BEAM OR COLUMN																			
A-1200	1-5/8	12	441	.914	258	.533	129	.267	3,108	A-1202	3-1/4	12	1,215	.509		.533	637	.267	7,675
B-1200	13/16	12			42	.533	21	.267	—	B-1202	1-5/8	12	378	1.019	197	.533	99	.267	—
C-1200	1-3/8	12	323	1.059	163	.533	81	.267	1,960	C-1202	2-3/4	12	903	.603		.533	400	.267	6,640
E-1200	2-7/16	12	831	.730		.533	355	.267	5,423	E-1202	4-7/8	12	2,440	.340		.533	1,917	.267	10,875
H-1200	3-1/4	12	1,323	.478		.533	739	.267	7,059	H-1202	6-1/2	12	4,021	.255		.533		.267	14,120
A-1400	1-5/8	14	304	.903	180	.533	90	.267	2,615	A-1402	3-1/4	14	856	.509		.533	449	.267	5,951
B-1400	13/16	14			32	.533	16	.267	—	B-1402	1-5/8	14	288	1.020	150	.533	75	.267	—
108" BEAM OR COLUMN																			
A-1200	1-5/8	12	393	1.156	204	.600	102	.300	2,456	A-1202	3-1/4	12	1,080	.644		.600	503	.300	6,071
B-1200	13/16	12			33	.600	16	.300	—	B-1202	1-5/8	12	355	1.290	156	.600	78	.300	—
C-1200	1-3/8	12	288	1.350	128	.600	64	.300	—	C-1202	2-3/4	12	801	.763	632	.600	316	.300	5,250
E-1200	2-7/16	12	739	.790	561	.600	281	.300	4,291	E-1202	4-7/8	12	2,169	.430		.600	1,515	.300	8,599
H-1200	3-1/4	12	1,176	.605		.600	584	.300	5,579	H-1202	6-1/2	12	3,574	.323		.600		.300	11,160
A-1400	1-5/8	14	270	1.141	142	.600	71	.300	1,708	A-1402	3-1/4	14	761	.644		.600	355	.300	4,702
B-1400	13/16	14			25	.600	13	.300	—	B-1402	1-5/8	14	255	1.290	119	.600	59	.300	—
120" BEAM OR COLUMN																			
A-1200	1-5/8	12	354	1.425	165	.667	83	.333	—	A-1202	3-1/4	12	971	.795		.667	408	.333	—
B-1200	13/16	12			27	.667	13	.333	—	B-1202	1-5/8	12	301	1.588	126	.667	63	.333	—
C-1200	1-3/8	12	259	1.663	104	.667	52	.333	—	C-1202	2-3/4	12	721	.941	512	.667	256	.333	4,250
E-1200	2-7/16	12	665	.976	455	.667	227	.333	3,478	E-1202	4-7/8	12	1,951	.531		.667	1,227	.333	6,946
H-1200	3-1/4	12	1,059	.746		.667	473	.333	4,521	H-1202	6-1/2	12	3,216	.398		.667		.333	9,040
A-1400	1-5/8	14	244	1.413	114	.667	57	.333	—	A-1402	3-1/4	14	685	.796		.667	287	.333	3,805
B-1400	13/16	14			21	.667	10	.333	—	B-1402	1-5/8	14	230	1.600	96	.667	48	.333	—
144" BEAM OR COLUMN																			
A-1200	1-5/8	12			115	.800	57	.400	—	A-1202	3-1/4	12	810	1.145	566	.800	283	.400	—
—										B-1202	1-5/8	12			88	.800	44	.400	—
C-1200	1-3/8	12			72	.800	36	.400	—	C-1202	2-3/4	12	601	1.350	355	.800	178	.400	—
E-1200	2-7/16	12	554	1.400	315	.800	158	.400	—	E-1202	4-7/8	12	1,626	.764		.800	852	.400	—
H-1200	3-1/4	12	883	1.075	657	.800	328	.400	—	H-1202	6-1/2	12	2,680	.573		.800	1,873	.400	—
A-1400	1-5/8	14			80	.800	40	.400	—	A-1402	3-1/4	14	571	1.146	399	.800	199	.400	—
—										B-1402	1-5/8	14			67	.800	33	.400	—
—																			

SECTION 9

Engineering Data and Specifications

Design Data - Metal Framing Channel
TABLE 3 continued

SINGLE CHANNEL										DOUBLE CHANNELS (Single Channels welded back to back)									
Prod. #	Depth	Ga.	Maximum Uniform		1/180 Span		1/360 Span		Col. Load	Prod. #	Depth	Ga.	Maximum Uniform		1/180 Span		1/360 Span		Col. Load
			Load	Defl.	Load	Defl.	Load	Defl.					Load	Defl.	Load	Defl.	Load	Defl.	
168" BEAM OR COLUMN																			
A-1200	1-5/8	12			84	.933	42	.467	—	A-1202	3-1/4	12	694	1.563	916	.933	208	.467	—
—										B-1202	1-5/8	12			64	.933	32	.467	—
C-1200	1-3/8	12			53	.933	27	.467	—	C-1202	2-3/4	12	515	1.850	261	.933	130	.467	—
E-1200	2-7/16	12	475	1.912	233	.933	116	.467	—	E-1202	4-7/8	12	1,394	1.040	1,255	.933	626	.467	—
H-1200	3-1/4	12	756	1.463	482	.933	241	.467	—	H-1202	6-1/2	12	2,298	.780		.933	1,326	.467	—
A-1400	1-5/8	14			60	.933	30	.467	—	A-1402	3-1/4	14	489	1.563	293	.933	147	.467	—
—										B-1402	1-5/8	14			49	.933	25	.467	—
192" BEAM OR COLUMN																			
—										A-1202	3-1/4	12			318	1.07	159	.533	—
—										C-1202	2-3/4	12			200	1.07	100	.533	—
E-1200	2-7/16	12			178	1.07	89	.533	—	E-1202	4-7/8	12	1,220	1.363	958	1.07	479	.533	—
H-1200	3-1/4	12	661	1.91	369	1.07	185	.533	—	H-1202	6-1/2	12	2,010	1.019		1.07	1,053	.533	—
—										A-1402	3-1/4	14			224	1.07	112	.533	—
—																			
216" BEAM OR COLUMN																			
—										A-1202	3-1/4	12			252	1.20	126	.600	—
—										C-1202	2-3/4	12			158	1.20	79	.600	—
E-1200	2-7/16	12			140	1.20	70	.600	—	E-1202	4-7/8	12	1,084	1.725	757	1.20	379	.600	—
H-1200	3-1/4	12			292	1.20	146	.600	—	H-1202	6-1/2	12	1,788	1.288		1.20	832	.600	—
—										A-1402	3-1/4	14			177	1.20	89	.600	—
—																			
240" BEAM OR COLUMN																			
—										A-1202	3-1/4	12			204	1.33	102	.667	—
—										C-1202	2-3/4	12			128	1.33	64	.667	—
E-1200	2-7/16	12			114	.334	57	.667	—	E-1202	4-7/8	12			613	1.33	307	.667	—
H-1200	3-1/4	12			236	.334	118	.667	—	H-1202	6-1/2	12	1,609	1.588		1.33	674	.667	—
—										A-1402	3-1/4	14			144	1.33	72	.667	—
—																			

When no numbers are shown, use the maximum uniform load.
deflections - in inches loads - in lbs.

Design Data - Metal Framing Channel

TABLE 4

Safe bearing loads for 1-5/8" channel and combinations.
Safety factor of 2-1/2

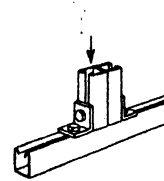
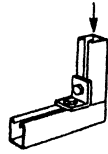
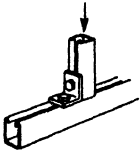

Section	Recommended Load in lbs.
A-1200	5000
A-1400	3500
B-1200	6000
B-1400	3400
C-1200	5000
E-1200	5000
H-1200	4000

Section	Recommended Load in lbs.
A-1200	3500
A-1400	2500
B-1200	4000
B-1400	2600
C-1200	3500
E-1200	3500
H-1200	2000

Section	Recommended Load in lbs.
A-1200	8000
A-1400	5500
B-1200	9000
B-1400	4800
C-1200	8000
E-1200	8000
H-1200	5500

TABLE 5

Design load table for typical channel connections.

Safety factor of 2-1/2 based on ultimate strength of the connection. Load diagrams indicate up to three design loads, for 12 gauge, 14 gauge and 16 gauge channel applications.

90° Fittings (When used in position shown)

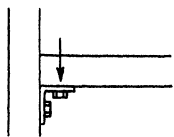

AB-202 A-1200 1500 lbs.
A-1400 1000 lbs.

Both ends supported

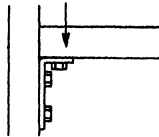

AB-203 A-1200 2000 lbs.
A-1400 1500 lbs.

Both ends supported

700 lbs.

700 lbs.

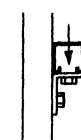

AB-201

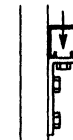

AB-203

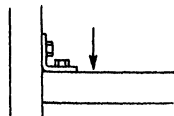

AB-202 A-1200 1000 lbs.
A-1400 650 lbs.

Both ends supported

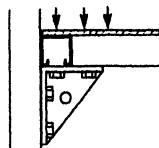

AB-213 A-1200 3000 lbs.
AB-214 A-1400 2000 lbs.

Both ends supported

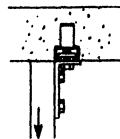

1500 lbs. AB-20

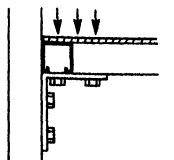

AB-205 A-1200 2000 lbs.
AB-216 A-1400 2000 lbs.

Both ends supported

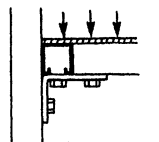

AB-204 A-1200 1500 lbs.
AB-215 A-1400 1000 lbs.

Both ends supported

Flat Plate Fittings



AB-206 A-1200 1000 lbs.
A-1400 800 lbs.

Both ends supported

Design Applications
CANTILEVER BEAMS

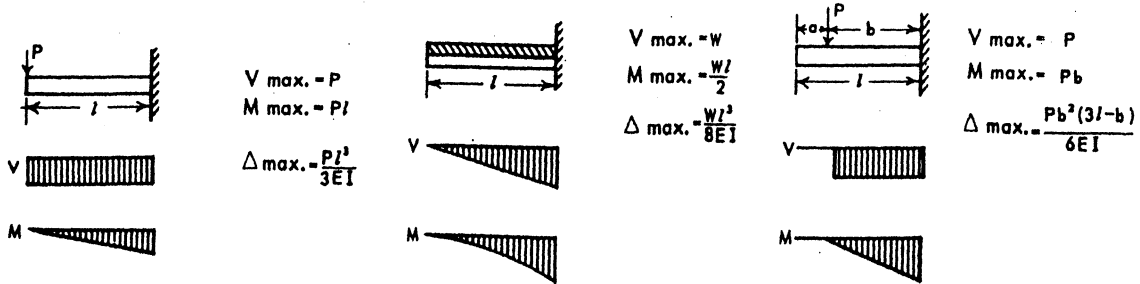

SIMPLE BEAMS

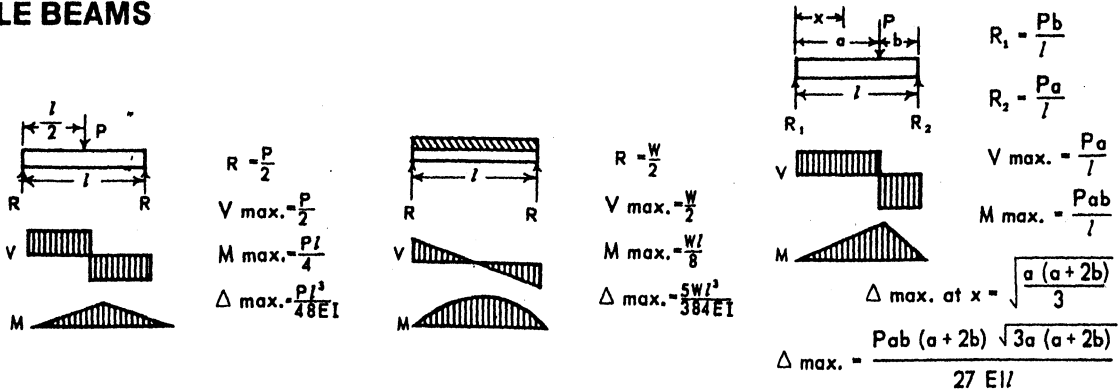

BEAMS FIXED ONE END, SUPPORTED AT OTHER

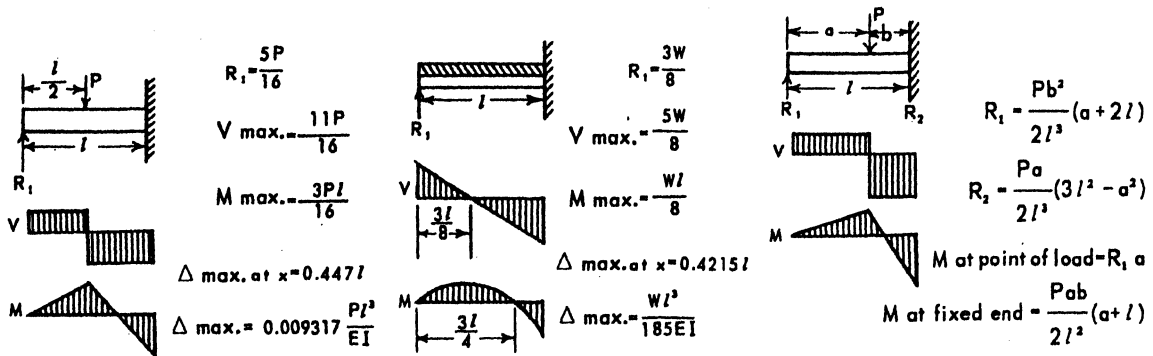

BEAMS FIXED AT BOTH ENDS

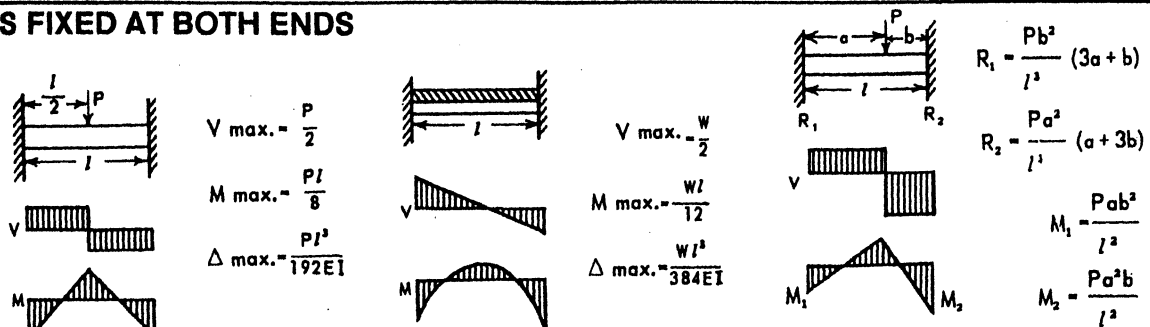

R - Reaction
M - Moment
P - Concentrated load

W - Total uniform load
V - Shear

Δ - Deflection
E - Modulus of Elasticity
I - Moment of Inertia







Design Applications

TABLE 6

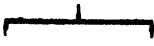
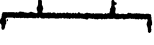
Conversion Factors for Beams with Various Static Loading Conditions

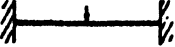
Load tables on pages 59 thru 64 for A, B, C, E and H series channel are for single span beams supported at the ends. These can be used in the majority of cases. There are times when it is necessary to know what happens

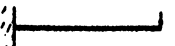
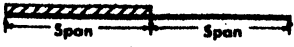
with other loading and support conditions. Some common arrangements are shown in Table 6. Simply multiply the loads from the Design Load Tables times the factors given in Table 6. Examples shown on page 68.

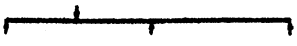
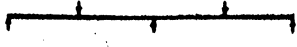
LOAD AND SUPPORT CONDITION		Load Factor	Deflection Factor
1. Simple Beam — Uniform Load		1.00	1.00
2. Simple Beam — Concentrated Load at Center		.50	.80
3. Simple Beam — Two Equal Concentrated Loads at 1/4 Points		1.00	1.10
4. Beam Fixed at Both Ends — Uniform Load		1.50	.30
5. Beam Fixed at Both Ends — Concentrated Load at Center		1.00	.40
6. Cantilever Beam — Uniform Load		.25	2.40
7. Cantilever Beam — Concentrated Load at End		.12	3.20
8. Continuous Beam — Two Equal Spans — Uniform Load on One Span		1.30	.92
9. Continuous Beam — Two Equal Spans — Uniform Load on Both Ends		1.00	.42
10. Continuous Beam — Two Equal Spans — Concentrated Load at Center of One Span		.62	.71
11. Continuous Beam — Two Equal Spans — Concentrated Load at center of Both Spans		.67	.48

Design Applications

EXAMPLE I

PROBLEM:

Determine load and deflection of an A-1200 beam continuous over one support and loaded uniformly on one span.

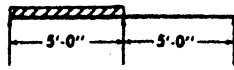

SOLUTION:

- A. From load table 3 for A-1200 the load for a 5'0" span is 706 lbs. and deflection is .358".
- B. Multiply by factors from Table 9.
Load = 706 lbs. X 1.30 = 917.8 lbs.
Deflection = .358 X .92 = .329"

EXAMPLE II

PROBLEM:

Determine load and deflection of an E-1200 cantilever beam with a concentrated load on the end.



SOLUTION:

- A. From load table 3 for E-1200 the load for a 3'0" span is 2216 lbs. and deflection is .088".
- B. Multiply by factors from Table 9.
Load = 2216 lbs. X .12 = 265.9 lbs.
Deflection = .088" X 3.20 = .282"

COLUMN LOADING

The load bearing capacity of columns or compression members is a function of the inherent configurational strength, the unbraced length and design of the end connections.

Values of axial column loading given in Table 3 were calculated using a rotationally free and translation fixed correction at each end.

(see Illustration I.) This gives an end condition constant (K) of 1.

If other end conditions are used, axial loading should be calculated using procedures in the AISI specification for the design of cold formed steel structural members (SG671) and the engineering values for Superstrut channel given in Table 1.

ILLUSTRATION I

COLUMN HEIGHT

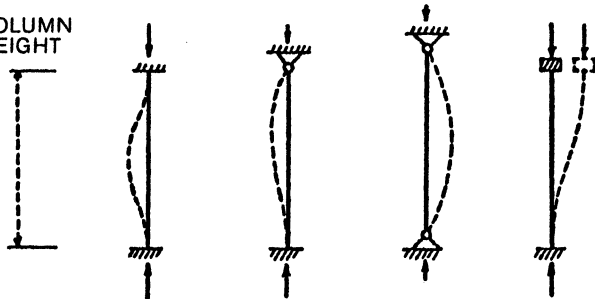

END CONDITION CODE

- Rotation fixed and translation fixed
- Rotation free and translation fixed
- Rotation fixed and translation free

K value .65 .80 1.0 1.2

TABLE 7

Load Carrying Capacities of Hot Rolled Steel Rod

DIMENSIONS (Inches) - LOADS

Nominal Rod Dia.	Root Area Thread	Design Load lbs. for Serv. Temperature	
		650°F	750°F
3/8	.068	610	540
1/2	.126	1130	1010
5/8	.202	1810	1610
3/4	.302	2710	2420
7/8	.419	3770	3360

Safety factor of 5

TABLE 8

Rod Size Determined by Pipe Size for Fire Protection

DIMENSIONS (Inches)

Pipe Size	Rod Size
3/4 to 2	3/8
2-1/2 to 3-1/2	1/2
4 to 5	5/8
6	3/4
8 to 12	7/8

Design Applications

TABLE 9

Maximum Spacing between Pipe Supports

STEEL PIPE																				
Nom. Pipe Size (inches)	1/2	3/4	1		1-1/2	2	2-1/2	3	3-1/2	4	5	6	8	10	12	14	16	18	20	24
Max. Spacing (feet)	5	6	7		9	10	11	12	13	14	16	17	19	22	23	25	27	28	30	32
COPPER PIPE																				
Nom. Pipe Size (inches)	1/2	3/4	1	1-1/4	1-1/2	2	2-1/2	3	3-1/2	4										
Max. Spacing (feet)	5	6	6	7	8	9	10	10	11	12										

TABLE 10

Minimum Spacing (inches) between Centers of Standard Pipe When Using Superstrut #702 Pipe Straps

Nom. Pipe Size	1/2	3/4	1	1-1/4	1-1/2	2	2-1/2	3	3-1/2	4	5	6	8
1/2	1 ³ / ₁₆												
3/4	1 ⁵ / ₁₆	1 ⁷ / ₁₆											
1	1 ¹ / ₂	1 ³ / ₈	1 ¹ / ₄										
1-1/4	1 ³ / ₄	1 ³ / ₄	2	2 ¹ / ₄									
1-1/2	1 ¹⁵ / ₁₆	2 ¹ / ₁₆	2 ³ / ₁₆	2 ⁷ / ₁₆	2 ⁹ / ₁₆								
2	2 ³ / ₁₆	2 ⁵ / ₁₆	2 ¹ / ₂	2 ³ / ₄	2 ⁷ / ₈	3 ¹ / ₈							
2-1/2	2 ⁷ / ₁₆	2 ⁹ / ₁₆	2 ³ / ₄	3	3 ¹ / ₈	3 ³ / ₈	3 ⁵ / ₈						
3	2 ¹³ / ₁₆	2 ¹⁵ / ₁₆	3 ¹ / ₁₆	3 ⁵ / ₁₆	3 ⁷ / ₁₆	3 ³ / ₄	4	4 ⁵ / ₁₆					
3-1/2	3 ¹ / ₈	3 ³ / ₈	3 ³ / ₈	3 ⁵ / ₈	3 ³ / ₄	4 ¹ / ₁₆	4 ⁵ / ₁₆	4 ³ / ₈	4 ¹⁵ / ₁₆				
4	3 ⁷ / ₁₆	3 ⁹ / ₁₆	3 ¹⁵ / ₁₆	4 ¹ / ₁₆	4 ³ / ₈	4 ³ / ₈	4 ¹⁵ / ₁₆	5 ¹ / ₁₆	5 ⁹ / ₁₆				
6	4 ³ / ₈	4 ⁵ / ₈	5	5 ¹ / ₈	5 ³ / ₈	5 ⁵ / ₈	5 ⁷ / ₈	6 ³ / ₁₆	6 ¹ / ₂	6 ¹³ / ₁₆	7 ¹ / ₁₆	8 ¹ / ₈	
8	5 ⁷ / ₁₆	6	6 ¹ / ₈	6 ³ / ₈	6 ¹ / ₂	6 ³ / ₄	7	7 ⁵ / ₁₆	7 ³ / ₈	8	8 ⁹ / ₁₆	9 ¹ / ₄	10 ¹ / ₈

SECTION 9

Engineering Data and Specifications

Design Applications

TABLE 11

Standard Dimensions and Weights of Piping Materials and Conduit

Mechanical (Schedule 40)				
Nominal Std. Pipe Size (inches)	Pipe O.D. (inches)	Coupling O.D. (inches)	Weight of Pipe lbs./ft.	Weight of Pipe Filled W/Water lbs./ft.
1/2	.84	1.06	.85	.98
3/4	1.05	1.31	1.13	1.36
1	1.32	1.58	1.68	2.05
1-1/4	1.66	1.90	2.27	2.92
1-1/2	1.90	2.20	2.72	3.60
2	2.38	2.75	3.65	5.11
2-1/2	2.88	3.25	5.79	7.87
3	3.50	4.00	7.58	10.78
3-1/2	4.00	4.63	9.11	13.39
4	4.50	5.00	10.79	16.30
5	5.56	6.30	14.62	23.28
6	6.63	7.39	18.97	31.48
8	8.63	9.23	28.56	50.24
10	10.75		41.00	74.00
12	12.75		50.00	99.00
14	14.00		64.00	122.00
16	16.00		63.00	142.00
18	18.00		71.00	172.00
20	20.00		79.00	205.00
22	22.00		87.00	240.00
24	24.00		95.00	277.00
26	26.00		103.00	322.00
28	28.00		111.00	364.00
30	30.00		119.00	410.00

Electrical Conduit					
Nominal Conduit Size	Rigid Steel			Thin Wall (EMT)	
	Conduit O.D. (inches)	Weight of Conduit lbs./ft.	Weight of Conduit W/Non-lead Covered Conductor lbs./ft.*	Conduit O.D. (inches)	Weight of Conduit lbs./ft.
1/2	.84	.85	1.04	.71	.29
3/4	1.05	1.13	1.40	.92	.44
1	1.32	1.68	2.35	1.16	.64
1-1/4	1.66	2.28	3.58	1.51	.95
1-1/2	1.90	2.73	4.55	1.74	1.10
2	2.38	3.68	7.21	2.20	1.40
2-1/2	2.88	5.82	10.22	2.88	2.30
3	3.50	7.62	14.51	3.50	2.70
4	4.50	10.89	21.48	4.50	4.00

* Includes weight of heaviest conductor combination.

Design Applications

TABLE 12

Extra Strong Pipe (Schedule 80)

A.S.A. B36.10 SCHEDULE NOS. AND NOMINAL WALL THICKNESS DESIGNATIONS	Nominal Pipe Size (inches)	O.D. (inches)	Wall Thickness (inches)	I.D. (inches)	Weight of Pipe lbs./ft.	Water Weight per Ft. of Pipe lbs.	Weight of Pipe Filled W/Water lbs./ft.
EXTRA STRONG PIPE and SCHEDULE 80 PIPE (through 8")	3/8	.675	.126	.423	.74	.061	.801
	1/2	.840	.147	.546	1.09	.101	1.191
	3/4	1.050	.154	.742	1.47	.188	1.668
	1	1.315	.179	.957	2.17	.311	2.481
	1-1/4	1.660	.191	1.278	3.00	.555	3.555
	1-1/2	1.900	.200	1.500	3.63	.765	4.395
	2	2.375	.218	1.939	5.03	1.279	6.309
	2-1/2	2.875	.276	2.323	7.66	1.834	9.497
	3	3.500	.300	2.900	10.30	2.860	13.160
	3-1/2	4.000	.318	3.364	12.55	3.850	16.350
	4	4.500	.337	3.826	15.00	4.980	19.980
	5	5.563	.375	4.813	20.80	7.890	28.690
	6	6.625	.432	5.761	28.60	11.290	39.890
	8	8.625	.500	7.625	43.40	19.790	63.200
	EXTRA STRONG PIPE (10" through 24" OD)	10	10.750	.500	9.750	54.70	32.300
12		12.750	.500	11.750	65.40	47.000	112.400
14 OD		14.000	.500	13.000	72.10	57.500	129.600
16 OD		16.000	.500	15.000	82.80	76.500	159.300
18 OD		18.000	.500	17.000	93.50	98.400	191.900
20 OD		20.000	.500	19.000	104.10	122.800	226.900
24 OD		24.000	.500	23.000	125.50	180.100	305.600
SCHEDULE 80 PIPE (10" through 24" OD)		10	10.750	.593	9.564	64.30	31.100
	12	12.750	.687	11.376	88.50	44.000	132.500
	14 OD	14.000	.750	12.500	106.10	53.200	159.300
	16 OD	16.000	.842	14.314	136.50	69.700	206.200
	18 OD	18.000	.937	16.126	170.80	88.500	259.300
	20 OD	20.000	1.031	17.938	208.90	109.400	318.300
	24 OD	24.000	1.218	21.564	296.40	158.300	454.700

TABLE 13

Pipe Covering Weights (Thickness intended as guide, only)

Thickness and weight of calcium silicate covering.

Nominal Pipe Size	260°		360°		440°		525°		600°		700°		800°	
	Thick. (Inches)	lbs./ft.	Thick. (Inches)	lbs./ft.	Thick. (Inches)	lbs./ft.	Thick. (Inches)	lbs./ft.	Thick. (Inches)	lbs./ft.	Thick. (Inches)	lbs./ft.	Thick. (Inches)	lbs./ft.
1	1	.68	1	.68	1	.68	1	.68	1½	1.19	1½	1.19	1½	1.19
1-1/4	1	.75	1	.75	1	.75	1	.75	1½	1.27	1½	1.27	2	1.82
1-1/2	1	.88	1	.88	1	.88	1	.88	1½	1.45	1½	1.45	2	1.87
2	1	1.01	1	1.01	1	1.01	1½	1.53	1½	1.53	2	2.50	2	2.50
2-1/2	1	1.15	1	1.15	1	1.15	1½	1.69	1½	1.69	2	2.50	2½	3.22
3	1	1.28	1	1.28	1	1.28	1½	2.09	1½	2.09	2	2.98	2½	3.98
3-1/2	1	1.44	1	1.44	1½	2.29	1½	2.29	2	3.00	2	3.12	2½	4.30
4	1	1.60	1	1.60	1½	2.49	1½	2.49	2	3.49	2	3.49	2½	4.62
5	1	1.84	1	1.84	1½	2.84	1½	2.84	2	3.97	2	3.97	2½	5.92
6	1½	3.13	1½	3.13	1½	3.13	1½	3.13	2	4.54	2	4.54	2½	6.75
8	1½	4.06	1½	4.06	1½	4.06	1½	4.06	2	5.56	2	5.56	2½	7.61

SECTION 9

Engineering Data and Specifications

Design Applications

TABLE 14

Column Loading For Rack Construction

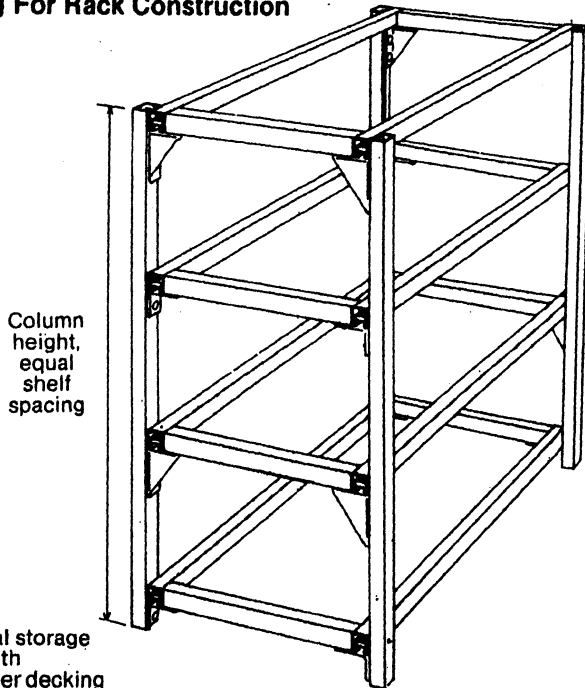

Typical general storage rack for use with plywood or other decking

GENERAL STORAGE RACKS

PALLET RACKS

BARREL RACKS

BULK FURNITURE RACKS

CABLE RACKS

BAR STOCK RACKS

DISPLAY RACKS

SPECIAL PURPOSE RACKS

For Uniform Loads on Horizontal Members See Table 3

Column Height	ALLOWABLE LOAD IN LBS. PER UPRIGHT									
	Prod. #	NUMBER OF SHELVES PER UPRIGHT								
		2	3	4	5	6	7	8	9	10
6'	A-1200	2237	1925	1650	1437	1290				
	A-1202	4170	3580	3100	2730	2450				
	B-1400	800	820	790	700	630				
	B-1402	1930	1700	1500	1300	1190				
7'	A-1200	2150	1850	1630	1425	1280	1150			
	A-1202	4000	3525	3000	2700	2430	2200			
	B-1400	650	790	760	685	615	550			
	B-1402	1800	1650	1450	1300	1180	750			
8'	A-1200	2000	1820	1600	1400	1250	1150	1050		
	A-1202	3900	3475	3000	2700	2400	2185	2000		
	B-1400	580	750	730	660	610	540	510		
	B-1402	1650	1610	1450	1300	1160	940	970		
9'	A-1200	1950	1780	1575	1400	1250	1130	1030	350	
	A-1202	3800	3400	3020	2675	2400	2180	1975	1100	
	B-1400		600	665	600	580	540	500	475	
	B-1402	1500	1500	1430	1275	1160	1000	900	800	
10'	A-1200	1870	1700	1500	1300	1200	1100	1000	900	800
	A-1202	3600	3300	3000	2650	2350	2000	1975	1800	1650
	B-1400		550	650	625	580	535	490	450	425
	B-1402	1450	1480	1400	1250	1140	1040	960	885	825

SECTION 10

Alphanumeric Index

Cat. No.	Page	Cat. No.	Page	Cat. No.	Page	Cat. No.	Page
A-100-1/4	7	A-809-3/4	47	AB-216	11	AB-857P	29
A-100-5/16	7	A-809-1	47	AB-219	12	AB-858P	29
A-100-3/8	7	A-853	47	AB-220	12	AB-859P	29
A-100-1/2	7	A-853-L	47	AB-225	14	AB-860P	29
A-100-5/8	7	A-854	48	AB-227	14	AB-861P	29
A-100-3/4	7	A-854-L	48	AB-239	14	AB-862P	29
A-100-7/8	7	A-889	48	AB-240	13	AB-863P	29
A-177-1/4 x 1	7	A-890	48	AB-241-1/4	13	AB-864P	29
A-177-1/4 x 1 1/4	7	A-891	48	AB-241-5/16	13	AB-865P	29
A-179-3/8 x 1	7	A-892	48	AB-241-3/8	13	AB-866	48
A-179-3/8 x 1 1/4	7	A-893	48	AB-241-1/2	13	AB-866P	29
A-180-1/2 x 1	7	A-1200	4	AB-241-5/8	13	AB-867P	29
A-180-1/2 x 1 1/4	7	A-1200-HS	4	AB-241-3/4	13	AB-868P	29
A-182-1/4 x 1	7	A-1200-KO	4	AB-242	13	AB-869P	29
A-182-1/4 x 1 1/4	7	A-1200-P	4	AB-245	16	AB-870P	29
A-184-3/8 x 1	7	A-1200-S	4	AB-252-1	11	AB-871P	29
A-184-3/8 x 1 1/4	7	A-1202	5	AB-252-2	11	AB-872P	29
A-185-1/2 x 1	7	A-1202-A	5	AB-252-3	11	AB-873P	29
A-185-1/2 x 1 1/4	7	A-1202-B	5	AB-252-4	11	AB-880	29
A-208	16	A-1202-C	5	AB-253	13	AB-881	29
A-209	14	A-1202-HS	5	AB-254-L	11	AB-885	48
A-210	16	A-1203-A	5	AB-254-R	11	AB-887	48
A-211	16	A-1203-B	5	AB-255	13	AB-888	48
A-212	16	A-1203-C	5	AB-257	13	AC-100-1/4	7
A-217	14	A-1203-D	5	AB-260-L	11	AC-100-3/8	7
A-218	14	A-1204	5	AB-260-R	11	AC-100-1/2	7
A-302	21	A-1400	4	AB-261	13	AC-100-5/8	7
A-570	35	A-1400-HS	4	AB-263	13	AC-100-3/4	7
A-597	31	A-1400-KO	4	AB-265	13	AN-211	16
A-716-1/4	26	A-1400-P	4	AB-274	11	AN-270	18
A-716-3/8	26	A-1400-S	4	AB-284-L	12	AP-232	17
A-716-1/2	26	AB-100-1/4	7	AB-284-R	11	AP-235	17
A-716-5/8	26	AB-100-3/8	7	AB-288	16	AW-204	14
A-716-3/4	26	AB-100-1/2	7	AB-299	12	AW-205-L	15
A-716-7/8	26	AB-100-5/8	7	AB-840P	29	AW-205-R	15
A-716-1	26	AB-100-3/4	7	AB-841P	29	AW-214	15
A-716-1 1/8	26	AB-102-1/4	22	AB-842P	29	AW-219	15
A-716-1 1/4	26	AB-102-3/8	22	AB-843P	29	AW-220-L	15
A-716-1 1/2	26	AB-102-1/2	22	AB-844-R	22	AW-224-R	15
A-716-1 5/8	26	AB-102-3/4	22	AB-844P	29	AW-226	15
A-716-1 3/4	26	AB-102-7/8	22	AB-845P	29	AW-228	15
A-716-1 7/8	26	AB-201	11	AB-846P	29	B-100-1/4	7
A-716-2	26	AB-202	11	AB-847P	29	B-100-5/8	7
A-716-2 1/8	26	AB-203	11	AB-848P	29	B-100-3/4	7
A-716-2 3/8	26	AB-204	11	AB-849P	29	B-100-1/2	7
A-716-2 5/8	26	AB-205	11	AB-850P	29	B-209	14
A-716-3 1/8	26	AB-206	12	AB-851P	29	B-210	16
A-716-4 1/8	26	AB-207	12	AB-852P	29	B-302	21
A-802	47	AB-213	11	AB-853P	29	B-450	21
A-804	47	AB-214	11	AB-854P	29	B-802	52
A-805	47			AB-855P	29	B-804	52
				AB-856P	29	B-822	52
				AB-844-L	49		

Alphanumeric Index

SECTION 10

Cat. No.	Page	Cat. No.	Page	Cat. No.	Page	Cat. No.	Page
B-1200	4	C-711-8	40	C-725-10	29	E-120-3/8	8
B-1200-HS	4	C-711-10	40	C-725-12	29	E-120-1/2	8
B-1200-P	4	C-711-12	40	C-728	41	E-122-3/8	8
B-1200-S	4	C-715-1/2	26	C-728-H	41	E-122-1/2	8
B-1202	5	C-715-3/4	26	C-749-N	42	E-130-3/8	8
B-1400	4	C-715-1	26	C-749-N-5/8	42	E-130-1/2	8
B-1400-HS	4	C-715-1 1/4	26	C-749-N-7/8	42	E-131-3/8	8
B-1400-P	4	C-715-1 1/2	26	C-749-N-1 1/8	42	E-131-1/2	8
B-1400-S	4	C-715-2	26	C-775-L-3/8	35	E-142-1/4 x 1	8
C-209	14	C-715-2 1/2	26	C-775-L-1/2	35	E-142-1/4 x 1 1/2	8
C-210	16	C-715-3	26	C-775-L-5/8	35	E-142-3/8 x 1	8
C-475-3/8	22	C-715-3 1/2	26	C-775-L-3/4	35	E-142-3/8 x 1 1/2	8
C-475-1/2	22	C-715-4	26	C-775-L-7/8	35	E-142-1/2 x 1 5/16	8
C-475-5/8	22	C-716-3/8	26	C-781-3/8	36	E-142-1/2 x 1 1/2	8
C-475-3/4	22	C-716-1/2	26	C-781-1/2	36	E-145-1/4	7
C-475-7/8	22	C-716-3/4	26	C-781-5/8	36	E-145-3/8	7
C-708-U-1/2	27	C-716-1	26	C-781-3/4	36	E-145-1/2	7
C-708-U-3/4	27	C-716-1 1/4	26	C-804	47	E-145-5/8	7
C-708-U-1	27	C-716-1 1/2	26	C-805	47	E-145-3/4	7
C-708-U-1 1/4	27	C-716-2	26			E-145-7/8	7
C-708-U-1 1/2	27	C-716-2 1/2	26	C-790-1A	45	E-145-1	7
C-708-U-2	27	C-716-3	26	C-1200	4	E-146-1/4	7
C-708-U-2 1/2	27	C-716-3 1/2	26	C-1200-HS	4	E-146-5/16	7
C-708-U-3	27	C-716-4	26	C-1200-P	4	E-146-3/8	7
C-708-U-3 1/2	27	C-720-1/2	28	C-1202	5	E-146-1/2	7
C-708-U-4	27	C-720-3/4	28	C-1202-A	5	E-146-5/8	7
C-708-U-5	27	C-720-1	28	C-1202-B	5	E-147-1/4	7
C-708-U-6	27	C-720-1 1/4	28	CL-710-1/2	40	E-147-5/16	7
C-710-1/2	38	C-720-1 1/2	28	CL-710-3/4	40	E-147-3/8	7
C-710-3/4	38	C-720-2	28	CL-710-1	40	E-147-1/2	7
C-710-1	38	C-720-2 1/2	28	CL-710-1 1/4	40	E-147-5/8	7
C-710-1 1/4	38	C-720-3	28	CL-710-1 1/2	40	E-147-3/4	7
C-710-1 1/2	38	C-720-3 1/2	28	CL-710-2	40	E-147-7/8	7
C-710-2	38	C-720-4	28	CL-710-2 1/2	40	E-148-1/4	7
C-710-2 1/2	38	C-720-5	28	CL-710-3	40	E-148-5/16	7
C-710-3	38	C-720-6	28	CL-710-3 1/2	40	E-148-3/8	7
C-710-3 1/2	38	C-720-8	28	CL-710-4	40	E-148-1/2	7
C-710-4	38	C-720-10	28	CM-100-1/4	7	E-148-5/8	7
C-710-5	38	C-720-12	28	CM-100-3/8	7	E-149-1/4 x 3/4	8
C-710-6	38	C-725-1/2	29	CM-100-1/2	7	E-149-1/4 x 1	8
C-710-8	38	C-725-3/4	29	CM-100B-1/2	7	E-149-5/16 x 1 1/4	8
C-710-10	38	C-725-1	29	CTL-710-1/2	39	E-149-3/8 x 1 1/4	8
C-710-12	38	C-725-1 1/4	29	CTL-710-3/4	39	E-150-S	8
C-711-1 1/4	40	C-725-1 1/2	29	CTL-710-1	39	E-151	8
C-711-1 1/2	40	C-725-2	29	CTL-710-1 1/4	39	E-210	16
C-711-2	40	C-725-2 1/2	29	CTL-710-1 1/2	39	E-802	47
C-711-2 1/2	40	C-725-3	29	CTL-710-2	39	E-804	47
C-711-3	40	C-725-3 1/2	29	CTL-710-2 1/2	39	E-805	47
C-711-3 1/2	40	C-725-4	29	CTL-710-3	39	E-1200	4
C-711-4	40	C-725-5	29	CTL-710-3 1/2	39	E-1200-HS	4
C-711-5	40	C-725-6	29	CTL-710-4	39	E-1200-P	4
C-711-6	40	C-725-8	29	CZ-209	14	E-1202	5

SECTION 10

Alphanumeric Index

Cat. No.	Page	Cat. No.	Page	Cat. No.	Page	Cat. No.	Page
EF-147-1/4	7	M-775-L-3/8	35	TS-272	18	U-597-2 1/2	37
EF-147-3/8	7	M-775-L-1/2	35	TS-273	18	U-597-3	37
EF-147-1/2	7	M-775-L-5/8	35	U-501	30	U-597-3 1/2	37
ES-142-1/2 x 1 1/2	7	M-775-L-3/4	35	U-502	30	U-597-4	37
ES-145-3/8	7	M-777-3/8	35	U-504	30	U-598-1/2	37
ES-145-1/2	7	M-777-1/2	35	U-505	30	U-598-3/4	37
EZ-209	14	M-777-5/8	35	U-510	31	U-598-1	37
H-100-3/8	7	M-777-3/4	35	U-514	31	U-598-1 1/4	37
H-100-1/2	7	M-777-7/8	35	U-514-A	31	U-598-1 1/2	37
H-100-5/8	7	M-778-3/8	36	U-515	31	U-598-2	37
H-104-1/4	8	M-778-1/2	36	U-515-B	31	U-598-2 1/2	37
H-104-3/8	8	PG-795	17	U-520	31	U-598-3	37
H-104-1/2	8	Q-205	17	U-521	31	U-598-3 1/2	37
H-104-5/8	8	Q-252-1 1/4	17	U-522	31	U-598-4	37
H-104-3/4	8	Q-252-2	17	U-550-1/4	32	U-599-1/2	37
H-104-7/8	8	Q-253	17	U-550-3/8	32	U-599-3/4	37
H-104-1	8	Q-254	17	U-550-1/2	32	U-599-1	37
H-115-1/2	9	Q-255	17	U-560-1/4	32	U-599-1 1/4	37
H-115-3/4	9	Q-256	18	U-560-3/8	32	U-599-1 1/2	37
H-115-1	9	S-201-L-6	18	U-560-1/2	32	U-599-2	37
H-115-1 1/4	9	S-201-R-6	18	U-560-5/8	32	U-599-2 1/2	37
H-115-1 1/2	9	S-201-L-8	18	U-562	33	U-599-3	37
H-115-2	9	S-201-R-8	18	U-563	33	U-861-1	30
H-115-2 1/2	9	S-201-L-10	18	U-564-3/8	33	U-861-2	30
H-115-3	9	S-201-R-10	18	U-564-1/2	33	U-861-3	30
H-115-3 1/2	9	S-201-L-12	18	U-564-5/8	33	U-861-4	30
H-115-4	9	S-201-R-12	18	U-568-1	34	U-861-5	30
H-115-5	9	S-201-L-14	18	U-568-2	34	U-861-6	30
H-115-6	9	S-201-R-14	18	U-568-3	34	U-861-7	30
H-115-8	9	S-201-L-16	18	U-568-4	34	U-861-8	30
H-115-10	9	S-201-R-16	18	U-568-5	34	US-562	33
H-115-12	9	S-201-L-18	18	U-568-6	34	US-563	33
H-119-1/4	9	S-201-R-18	18	U-568-7	34	X-201	12
H-119-5/16	9	S-201-L-20	18	U-568-8	34	X-204	12
H-119-3/8	9	S-201-R-20	18	U-569	34	X-207	12
H-119-1/2	9	S-204	18	U-571	37	X-208	12
H-119-5/8	9	S-205	18	U-572	37	X-289	12
H-119-3/4	9	S-217	18	U-576	34	X-299	12
H-119-7/8	9	S-218	19	U-577	34	452	22
H-119-1	9	S-226	19	U-579-3/8	34	512	31
H-119-1/4 to 3/8	9	S-236	19	U-579-1/2	34	540-3/8	32
H-119-3/8 to 1/2	9	S-247	19	U-597-1/2	37	540-1/2	32
H-119-1/2 to 5/8	9	S-248	19	U-597-3/4	37	540-5/8	32
H-119-5/8 to 3/4	9	S-250	19	U-597-1	37	540-3/4	32
H-119-3/4 to 7/8	9	S-251	19	U-597-1 1/4	37	540-7/8	32
H-802	47	S-256	19	U-597-1 1/2	37	542	32
H-804	47	S-222	19	U-597-2	37	700-3/8	24
H-805	47	S-716	27			700-1/2	24
H-1200	4					700-3/4	24
H-1200-HS	4					700-1	24
H-1200-P	4					700-1 1/4	24
H-1202	5					700-1 1/2	24

Cat. No.	Page	Cat. No.	Page
700-2	24	702-1¼	25
701-¼	24	702-1½	25
701-⅓	24	702-2	25
701-½	24	702-2½	25
701-⅔	24	702-3	25
701-¾	24	702-3½	25
701-⅞	24	702-4	25
701-1	24	702-5	25
701-1⅛	24	702-6	25
701-1¼	24	702-8	25
701-1⅓	24	703-½	25
701-1½	24	703-¾	25
701-1⅔	24	703-1	25
701-1¾	24	703-1¼	25
701-1⅞	24	703-1½	25
701-2	24	703-2	25
701-2⅛	24	703-2½	25
701-2¼	24	703-3	25
701-2⅓	24	703-3½	25
701-2½	24	703-4	25
701-2⅔	24	811-1	47
701-2¾	24	811-2	47
701-2⅞	24		
701-3	24		
701-3⅛	24		
701-3¼	24		
701-3⅓	24		
701-3½	24		
701-3⅔	24		
701-3¾	24		
701-3⅞	24		
701-4	24		
701-4⅛	24		
701-4¼	24		
701-4⅓	24		
701-4½	24		
701-4⅔	24		
701-4¾	24		
701-4⅞	24		
701-5	24		
701-5⅛	24		
701-5¼	24		
701-5⅓	24		
701-5½	24		
701-5⅔	24		
701-5¾	24		
701-5⅞	24		
701-6	24		
702-⅓	25		
702-½	25		
702-¾	25		
702-1	25		

SECTION 11

Cable Ladder System – American Specs. For Power, Control, Instrumentation, Cable and Pneumatic Tubing.

STRAIGHT LENGTH
Page 15

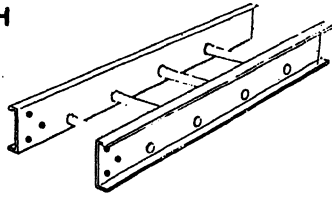

90° VERTICAL CABLE SUPPORT ELBOW
Page 24

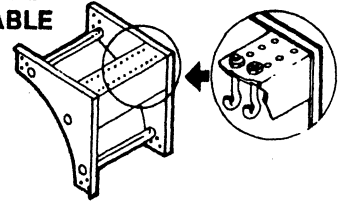

HORIZONTAL ELBOWS
Page 16

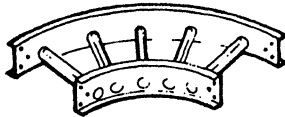

VERTICAL TEE
Page 25

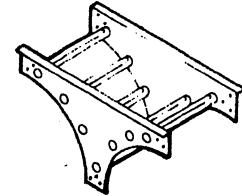

HORIZONTAL TEE
Page 18

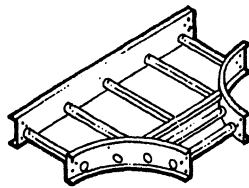

COVERS
Page 26

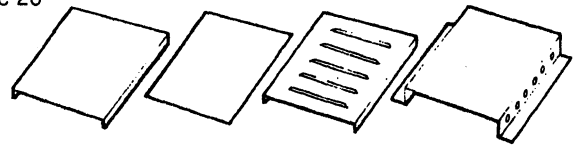

HORIZONTAL CROSS
Page 19

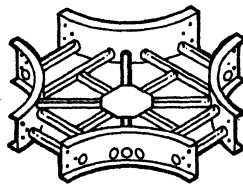

COVER ATTACHMENTS
Page 27

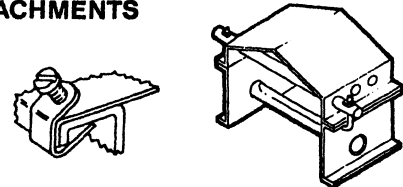

REDUCERS
Page 20

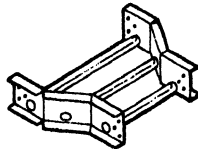

CONNECTORS
Page 28

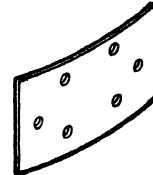

ADJUSTABLE ELBOWS
Page 21

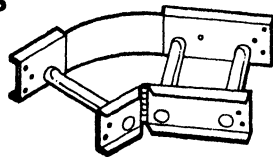

BARRIER STRIPS AND ACCESSORIES
Pages 29 to 33

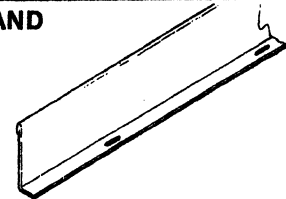

45° "Y" BRANCH
Page 21

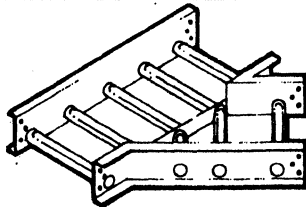

CABLE TRAY FIRESTOPS
Page 34

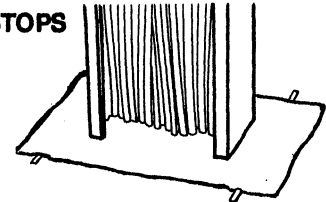

VERTICAL ELBOWS
Page 22

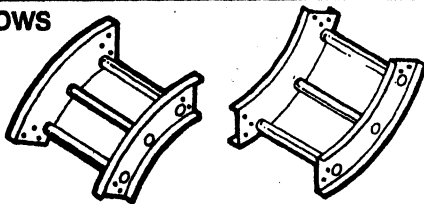

ROLLERS AND PULLEYS
Page 35

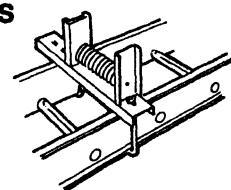

R-55 PERFORATED TRAY (55 mm SIDE RAIL HEIGHT)

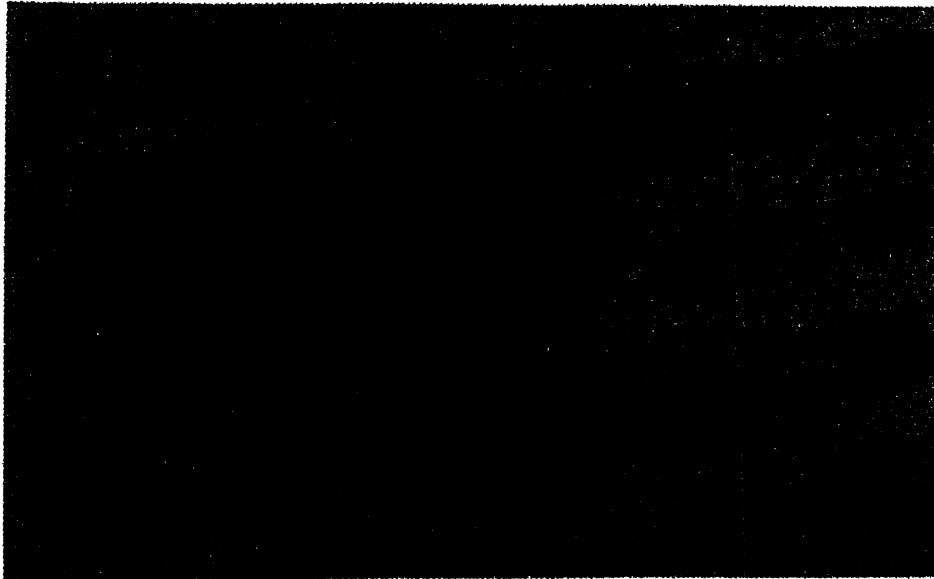

R-25 PERFORATED TRAY (25 mm SIDE RAIL HEIGHT)

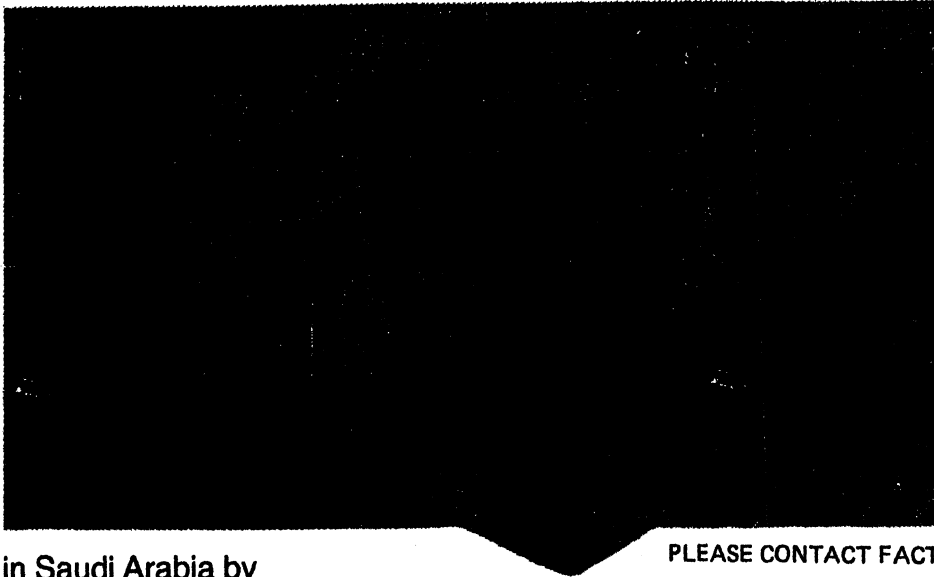

Manufactured in Saudi Arabia by

ABAHSAIN-COPE S.A. LTD.

PLEASE CONTACT FACTORY FOR DETAILS

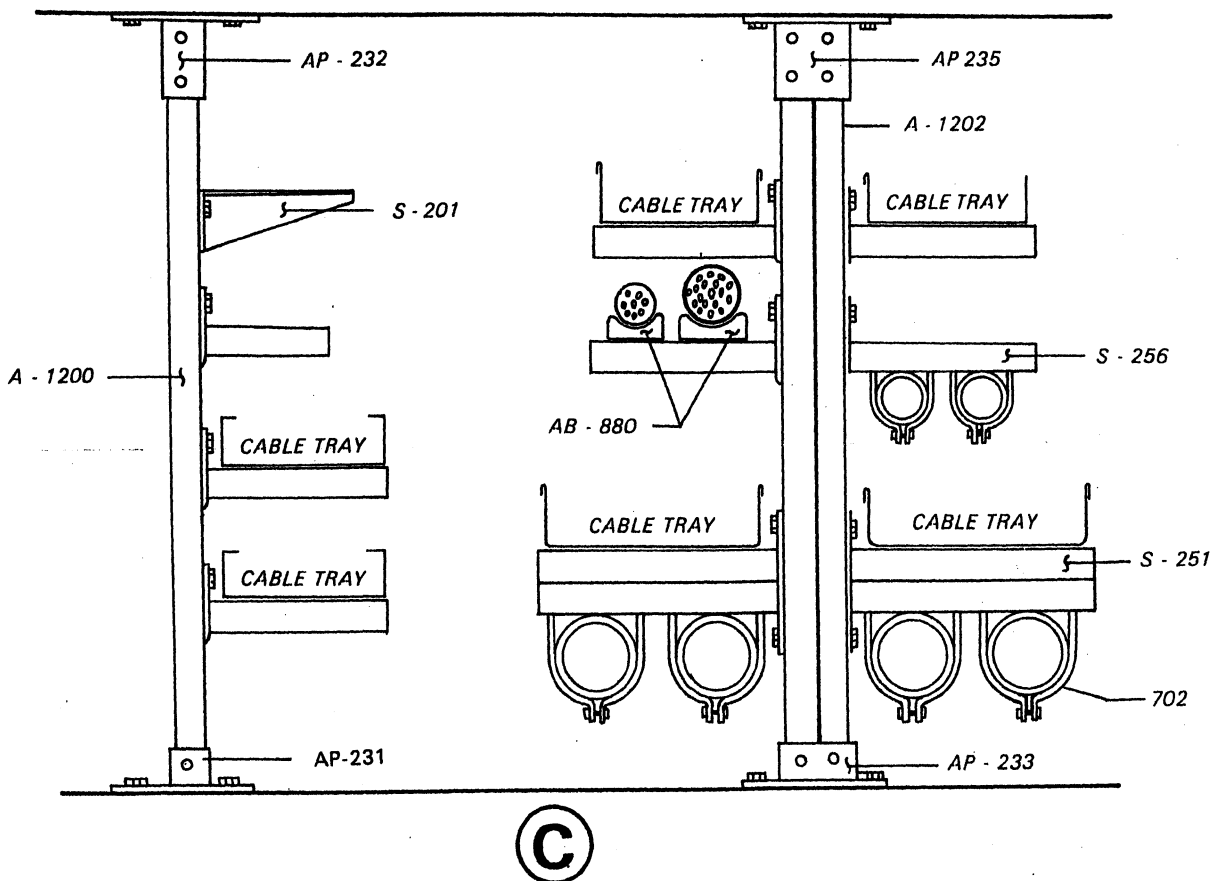
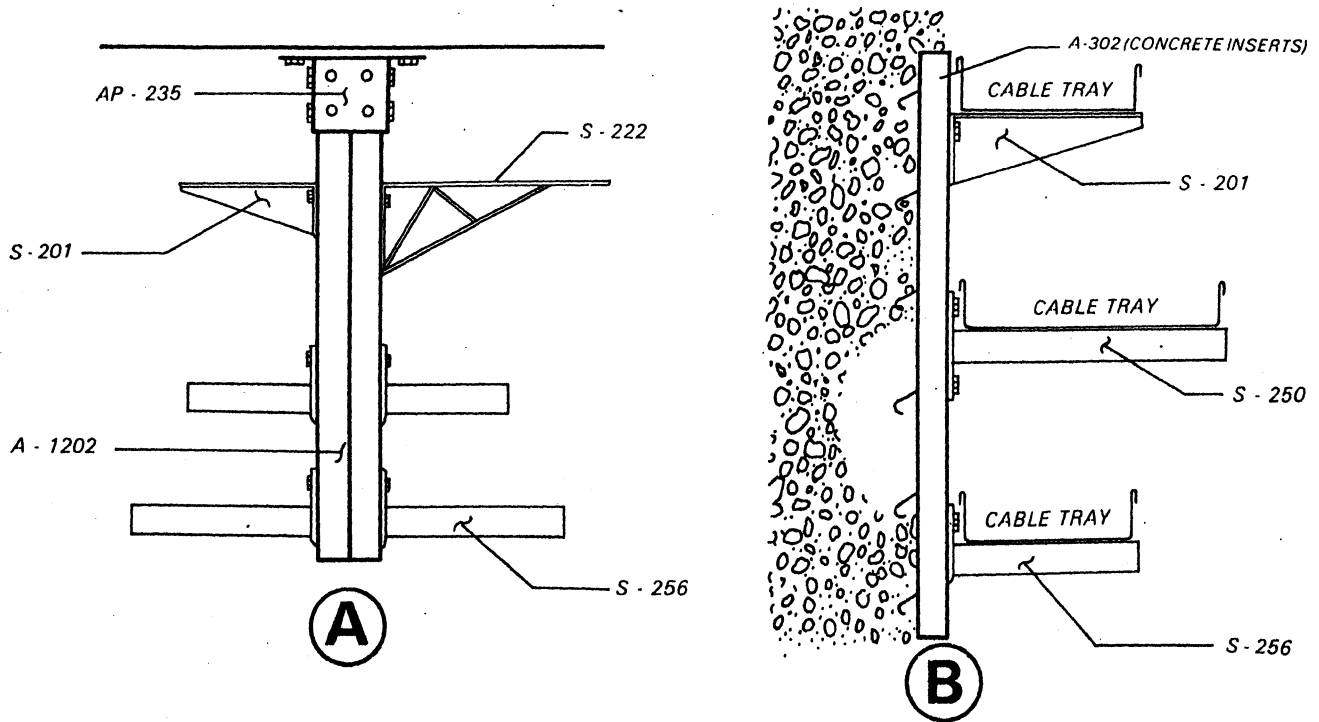

- A — SUSPENDED CEILING SUPPORT**
- B — WALL SUPPORT (using Concrete Insert)**
- C — FLOOR TO CEILING SUPPORT**

- A — U — 564 — S 1/2" Beam Clamp
 B — H — 104 1/2" Threaded Rod
 C — E — 145 1/2" Standard Hex Nut
 D — E — 147 1/2" Flat Steel Washer
 E — — 9017 Hold Down Clamp
 F — B — 1200 H.S. Channel 10' 1-5/8" x 13/16"
 G — H — 119 1/2" Rod Coupling
 H — A — 1200 10' 1-5/8" x 1-5/8" Half Slot
 I — AB — 100 1/2" Springless Unit —
 J — A — 1200 10' Channel 1-5/8" x 1-5/8"
 K — S — 250 6" — 24" Bracket
 L — A — 100 1/2" Spring Nut
 M — E — 142 1/2" x 1/2" Hex Head Cap Screw
 N — S — 236 — Bracket —
 O — S — 201 Left or Right 6" — 30"

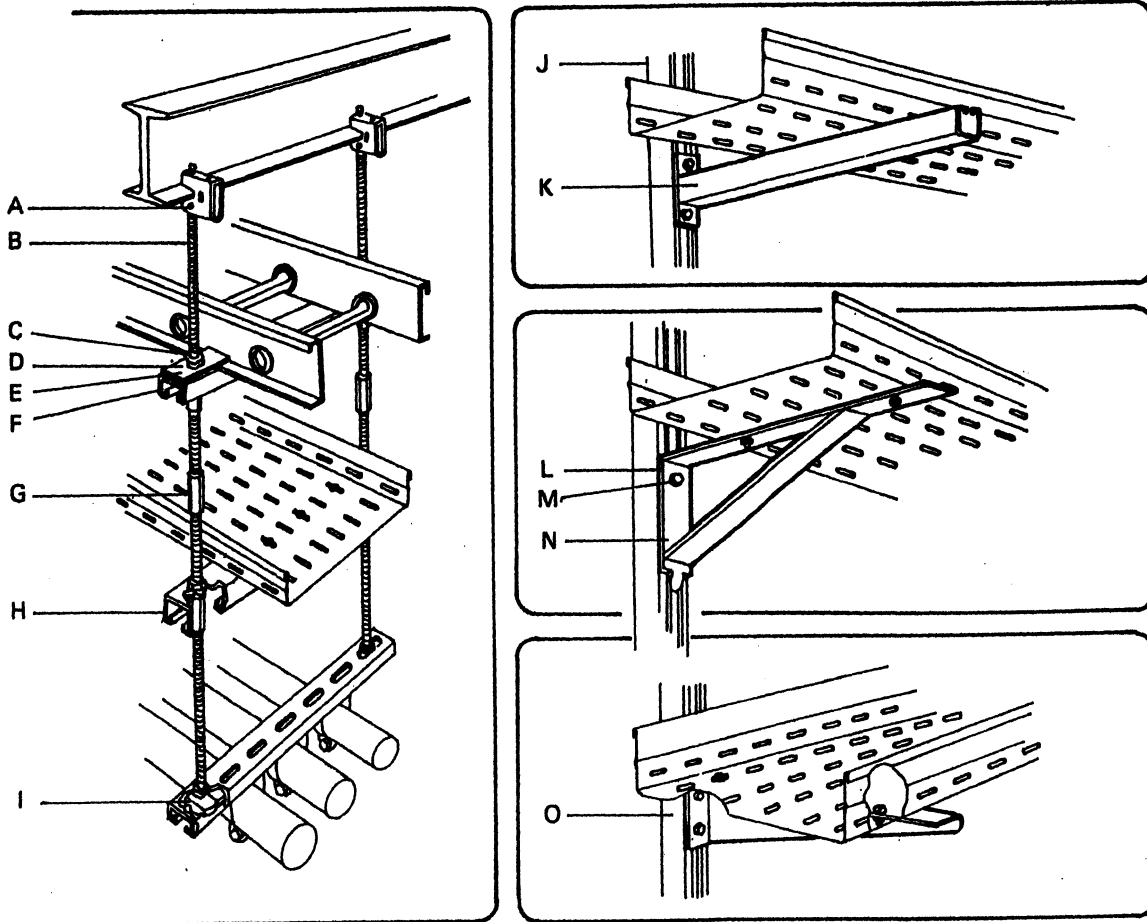

ABAHSAIN-COPE, SAUDI ARABIA MANUFACTURES:

1. Cope Cable Ladder — Nema Specifications — U.S.
2. Mavil Cable Trays — France (Solid & Perforated)
3. Saudi Superstrut Support Systems — ASTM Specifications — U.S.